



**THE DATASHEET OF
MB95F374LPMC1-G-SNE2**





**MB95F314E/F314L/F316E/F316L/F318E/F318L
MB95F374E/F374L/F376E/F376L/F378E/F378L**

New 8FX MB95310L/370L Series 8-bit Microcontrollers

MB95310L/370L is a series of general-purpose, single-chip microcontrollers. In addition to a compact instruction set, the microcontrollers of this series contain a variety of peripheral resources.

Features

F²MC-8FX CPU core

Instruction set optimized for controllers

- Multiplication and division instructions
- 16-bit arithmetic operations
- Bit test branch instructions
- Bit manipulation instructions, etc.

Clock

- Selectable main clock source
 - Main OSC clock (up to 16.25 MHz, maximum machine clock frequency: 8.125 MHz)
 - External clock (up to 32.5 MHz, maximum machine clock frequency: 16.25 MHz)
 - Main CR clock (1/8/10/12.5 MHz \pm 2%, maximum machine clock frequency: 12.5 MHz)
 - Main PLL clock (up to 16.25 MHz, maximum machine clock frequency: 16.25 MHz)
- Selectable subclock source
 - Sub-OSC clock (32.768 kHz)
 - External clock (32.768 kHz)
 - Sub-CR clock (Typ: 100 kHz, Min: 50 kHz, Max: 200 kHz)

Timer

- 8/16-bit composite timer
- 8/16-bit PPG
- 16-bit reload timer
- Event counter
- Time-base timer
- Watch prescaler

UART-SIO

- Capable of clock-asynchronous (UART) serial data transfer and clock-synchronous (SIO) serial data transfer
- Full duplex double buffer

I²C

Built-in wake-up function

External interrupt

- Interrupt by edge detection (rising edge, falling edge, and both edges can be selected)
- Can be used to wake up the device from different low power consumption (standby) modes

8/10-bit A/D converter

8-bit or 10-bit resolution can be selected

LCD controller (LCDC)

- 40 SEG \times 4 COM (MB95F314E/F314L/F316E/F316L/F318E/F318L)
- 32 SEG \times 4 COM (MB95F374E/F374L/F376E/F376L/F378E/F378L)
- Internal divider resistor
- With blinking function

Low power consumption (standby) modes

- Stop mode
- Sleep mode
- Watch mode
- Time-base timer mode

I/O port

- MB95F314E/F314L/F316E/F316L/F318E/F318L (maximum no. of I/O ports: 71)
General-purpose I/O ports (N-ch open drain): 3
General-purpose I/O ports (CMOS I/O): 68
- MB95F374E/F374L/F376E/F376L/F378E/F378L (maximum no. of I/O ports: 55)
General-purpose I/O ports (N-ch open drain): 3
General-purpose I/O ports (CMOS I/O): 52

On-chip debug

- 1-wire serial control
- Serial writing supported (asynchronous mode)

Hardware/software watchdog timer

- Built-in hardware watchdog timer
- Built-in software watchdog timer

Low-voltage detection reset circuit

- Built-in low-voltage detector
- Three configurable low-voltage detection levels for generating reset
- Five configurable low-voltage detection levels for generating interrupts

Clock supervisor counter

Built-in clock supervisor counter function

Programmable port input voltage level

CMOS input level / hysteresis input level

Dual operation Flash memory

The program/erase operation and the read operation can be executed in different banks (upper bank/lower bank) simultaneously.

Flash memory security function

Protects the content of the Flash memory

Contents

Product Line-up	3	Recommended Operating Conditions	42
Oscillation Stabilization Wait Time	7	DC Characteristics	43
Packages And Corresponding Products	7	AC Characteristics	47
Differences Among Products And Notes On		Clock Timing	47
Product Selection	8	Source Clock/Machine Clock	49
Pin Assignment	9	External Reset	52
Pin Description (MB95310L Series)	11	Power-on Reset	54
Pin Description (MB95370L Series)	16	Peripheral Input Timing	55
I/O Circuit Type	20	UART/SIO, Serial I/O Timing	56
Notes On Device Handling	22	Low-voltage Detection	58
Pin Connection	23	I2C Timing	60
Recommended Layout	24	A/D Converter	65
Block Diagram (MB95310L Series)	25	A/D Converter Electrical Characteristics	65
Block Diagram (MB95370L Series)	26	Notes on Using the A/D Converter	66
CPU Core	26	Definitions of A/D Converter Terms	67
I/O Map (MB95310L Series)	28	Flash Memory Program/Erase Characteristics	69
I/O Map (MB95370L Series)	34	Sample Characteristics	71
Interrupt Source Table	39	Mask Options	79
Electrical Characteristics	40	Ordering Information	80
Absolute Maximum Ratings	40	Package Dimension	80
		Major Changes	84

1. Product Line-up

■ MB95310L Series

Part number	MB95F314E	MB95F316E	MB95F318E	MB95F314L	MB95F316L	MB95F318L
Parameter						
Type	Flash memory product					
Clock supervisor counter	It supervises the main clock oscillation.					
Flash memory capacity	20 Kbyte	36 Kbyte	60 Kbyte	20 Kbyte	36 Kbyte	60 Kbyte
RAM capacity	496 bytes	1008 bytes	2032 bytes	496 bytes	1008 bytes	2032 bytes
Low-voltage detection reset	Yes			No		
Reset input	Dedicated					
CPU functions	<ul style="list-style-type: none"> • Number of basic instructions : 136 • Instruction bit length : 8 bits • Instruction length : 1 to 3 bytes • Data bit length : 1, 8 and 16 bits • Minimum instruction execution time : 61.5 ns (machine clock frequency = 16.25 MHz) • Interrupt processing time : 0.6 μs (machine clock frequency = 16.25 MHz) 					
General-purpose I/O	<ul style="list-style-type: none"> • I/O ports (Max) : 71 • CMOS I/O : 68 • N-ch open drain : 3 					
Time-base timer	Interval time: 0.256 ms - 8.3 s (external clock frequency = 4 MHz)					
Hardware/software watchdog timer	<ul style="list-style-type: none"> • Reset generation cycle Main oscillation clock at 10 MHz: 105 ms (Min) • The sub-CR clock can be used as the source clock of the hardware watchdog timer. 					
Wild register	It can be used to replace three bytes of data.					
I ² C	1 channel					
	<ul style="list-style-type: none"> • Master/Slave sending and receiving • Bus error function and arbitration function • Detecting transmitting direction function • Start condition repeated generation and detection functions • Built-in wake-up function 					
UART/SIO	2 channels					
	<ul style="list-style-type: none"> • Data transfer with UART/SIO is enabled. • It has a full duplex double buffer, variable data length (5/6/7/8 bits), a built-in baud rate generator and an error detection function. • It uses the NRZ type transfer format. • LSB-first data transfer and MSB-first data transfer are available to use. • Clock-asynchronous (UART) serial data transfer and clock-synchronous (SIO) serial data transfer is enabled. 					
8/10-bit A/D converter	4 channels					
	8-bit or 10-bit resolution can be selected.					

(Continued)

(Continued)

Part number	MB95F314E	MB95F316E	MB95F318E	MB95F314L	MB95F316L	MB95F318L
Parameter						
8/16-bit composite timer	2 channels <ul style="list-style-type: none"> Each timer can be configured as an "8-bit timer × 2 channels" or a "16-bit timer × 1 channel". It has built-in timer function, PWC function, PWM function and input capture function. Count clock: it can be selected from internal clocks (seven types) and external clocks. It can output square wave. 					
LCD controller (LCDC)	<ul style="list-style-type: none"> COM output: 4 (Max) SEG output: 40 (Max) LCD drive power supply (bias) pin: 4 (Max) 40 SEG × 4 COM: 160 pixels can be displayed Duty LCD mode Operate in LCD standby mode Blinking function Internal divider resistor for LCD drive 					
16-bit reload timer	1 channel <ul style="list-style-type: none"> Two clock modes and two counter operating modes can be selected Square waveform output Count clock: it can be selected from internal clocks (seven types) and external clocks. Counter operating mode: reload mode or one-shot mode can be selected 					
Event counter	By configuring the 16-bit reload timer and the 8/16-bit composite timer ch. 1, event counter function can be implemented. When the event counter function is used, the 16-bit reload timer and the 8/16-bit composite timer ch. 1 are unavailable.					
8/16-bit PPG	2 channels <ul style="list-style-type: none"> Each channel of the PPG can be used as "8-bit PPG × 2 channels" or "16-bit PPG × 1 channel" Counter operating clock: Eight selectable clock sources 					
Watch counter	<ul style="list-style-type: none"> Count clock: Four selectable clock sources (125 ms, 250 ms, 500 ms or 1 s) Counter value can be set from 0 to 63. (Capable of counting for 1 minute when selecting clock source of 1 second and setting counter value to 60) 					
External interrupt	8 channels <ul style="list-style-type: none"> Interrupt by edge detection (The rising edge, falling edge, or both edges can be selected.) It can be used to wake up the device from the standby mode. 					
On-chip debug	<ul style="list-style-type: none"> 1-wire serial control It supports serial writing. (asynchronous mode) 					
Watch prescaler	Eight different time intervals can be selected. (62.5 ms, 125 ms, 250 ms, 500 ms, 1 s, 2 s, 4 s, 8 s)					
Flash memory	<ul style="list-style-type: none"> It supports automatic programming, Embedded Algorithm, program/erase/erase-suspend/erase-resume commands. It has a flag indicating the completion of the operation of Embedded Algorithm. Number of program/erase cycles: 100000 Data retention time: 20 years Flash security feature for protecting the content of the Flash memory 					
Standby mode	Sleep mode, stop mode, watch mode, time-base timer mode					
Package	FPT-80P-M37					

■ MB95370L Series

Part number	MB95F374E	MB95F376E	MB95F378E	MB95F374L	MB95F376L	MB95F378L
Type	Flash memory product					
Clock supervisor counter	It supervises the main clock oscillation.					
Flash memory capacity	20 Kbyte	36 Kbyte	60 Kbyte	20 Kbyte	36 Kbyte	60 Kbyte
RAM capacity	496 bytes	1008 bytes	2032 bytes	496 bytes	1008 bytes	2032 bytes
Low-voltage detection reset	Yes			No		
Reset input	Dedicated					
CPU functions	<ul style="list-style-type: none"> • Number of basic instructions : 136 • Instruction bit length : 8 bits • Instruction length : 1 to 3 bytes • Data bit length : 1, 8 and 16 bits • Minimum instruction execution time : 61.5 ns (machine clock frequency = 16.25 MHz) • Interrupt processing time : 0.6 μs (machine clock frequency = 16.25 MHz) 					
General-purpose I/O	<ul style="list-style-type: none"> • I/O ports (Max): 55 • CMOS I/O: 52 • N-ch open drain: 3 					
Time-base timer	Interval time: 0.256 ms - 8.3 s (external clock frequency = 4 MHz)					
Hardware/software watchdog timer	<ul style="list-style-type: none"> • Reset generation cycle Main oscillation clock at 10 MHz: 105 ms (Min) • The sub-CR clock can be used as the source clock of the hardware watchdog timer. 					
Wild register	It can be used to replace three bytes of data.					
I ² C	1 channel					
	<ul style="list-style-type: none"> • Master/Slave sending and receiving • Bus error function and arbitration function • Detecting transmitting direction function • Start condition repeated generation and detection functions • Built-in wake-up function 					
UART/SIO	2 channels					
	<ul style="list-style-type: none"> • Data transfer with UART/SIO is enabled. • It has a full duplex double buffer, variable data length (5/6/7/8 bits), a built-in baud rate generator and an error detection function. • It uses the NRZ type transfer format. • LSB-first data transfer and MSB-first data transfer are available to use. • Clock-asynchronous (UART) serial data transfer and clock-synchronous (SIO) serial data transfer is enabled. 					
8/10-bit A/D converter	4 channels					
	8-bit or 10-bit resolution can be selected.					
8/16-bit composite timer	2 channels					
	<ul style="list-style-type: none"> • Each timer can be configured as an "8-bit timer × 2 channels" or a "16-bit timer × 1 channel". • It has built-in timer function, PWC function, PWM function and input capture function. • Count clock: it can be selected from internal clocks (seven types) and external clocks. • It can output square wave. 					

(Continued)

(Continued)

Part number	MB95F374E	MB95F376E	MB95F378E	MB95F374L	MB95F376L	MB95F378L
Parameter						
LCD controller (LCDC)	<ul style="list-style-type: none"> • COM output: 4 (Max) • SEG output: 32 (Max) • LCD drive power supply (bias) pin: 3 (Max) • 32 SEG × 4 COM: 128 pixels can be displayed 					
	<ul style="list-style-type: none"> • Duty LCD mode • Operate in LCD standby mode • Blinking function • Internal divider resistor for LCD drive 					
16-bit reload timer	1 channel					
	<ul style="list-style-type: none"> • Two clock modes and two counter operating modes can be selected • Square waveform output • Count clock: it can be selected from internal clocks (seven types) and external clocks. • Counter operating mode: reload mode or one-shot mode can be selected 					
Event counter	By configuring the 16-bit reload timer and the 8/16-bit composite timer ch. 1, event counter function can be implemented. When the event counter function is used, the 16-bit reload timer and the 8/16-bit composite timer ch. 1 are unavailable.					
8/16-bit PPG	2 channels					
	<ul style="list-style-type: none"> • Each channel of the PPG can be used as “8-bit PPG × 2 channels” or “16-bit PPG × 1 channel” • Counter operating clock: Eight selectable clock sources 					
Watch counter	<ul style="list-style-type: none"> • Count clock: Four selectable clock sources (125 ms, 250 ms, 500 ms or 1 s) • Counter value can be set from 0 to 63. (Capable of counting for 1 minute when selecting clock source of 1 second and setting counter value to 60) 					
External interrupt	8 channels					
	<ul style="list-style-type: none"> • Interrupt by edge detection (The rising edge, falling edge, or both edges can be selected.) • It can be used to wake up the device from the standby mode. 					
On-chip debug	<ul style="list-style-type: none"> • 1-wire serial control • It supports serial writing. (asynchronous mode) 					
Watch prescaler	Eight different time intervals can be selected. (62.5 ms, 125 ms, 250 ms, 500 ms, 1 s, 2 s, 4 s, 8 s)					
Flash memory	<ul style="list-style-type: none"> • It supports automatic programming, Embedded Algorithm, program/erase/erase-suspend/erase-resume commands. • It has a flag indicating the completion of the operation of Embedded Algorithm. • Number of program/erase cycles: 100000 • Data retention time: 20 years • Flash security feature for protecting the content of the Flash memory 					
Standby mode	Sleep mode, stop mode, watch mode, time-base timer mode					
Package	FPT-64P-M38 FPT-64P-M39					

2. Oscillation Stabilization Wait Time

The main CR clock oscillation stabilization wait time is fixed to the maximum value. Below is the maximum value.

Oscillation stabilization wait time	Remarks
$(2^{10} - 2) / F_{CRH}$	Approx. 128 μ s (when the main CR clock is 8 MHz)

The main PLL clock oscillation stabilization wait time is fixed to the maximum value. Below is the maximum value.

Oscillation stabilization wait time	Remarks
$(2^{14} - 2) / F_{CH}$	Approx. 14.1 ms (when the main PLL clock is 4 MHz)

3. Packages And Corresponding Products

Part number	MB95F314E	MB95F316E	MB95F318E	MB95F314L	MB95F316L	MB95F318L
Package						
FPT-80P-M37						O
FPT-64P-M38						X
FPT-64P-M39						X

Part number	MB95F374E	MB95F376E	MB95F378E	MB95F374L	MB95F376L	MB95F378L
Package						
FPT-80P-M37						X
FPT-64P-M38						O
FPT-64P-M39						O

O: Available

X: Unavailable

4. Differences Among Products And Notes On Product Selection

■ Current consumption

When using the on-chip debug function, take account of the current consumption of flash erase/write.

For details of current consumption, see “[Electrical Characteristics](#)”.

■ Package

For details of information on each package, see “[Packages And Corresponding Products](#)” and “[Electrical Characteristics](#)”.

■ Operating voltage

The operating voltage varies, depending on whether the on-chip debug function is used or not.

For details of the operating voltage, see “[Electrical Characteristics](#)”.

■ On-chip debug function

The on-chip debug function requires that V_{CC} , V_{SS} and 1 serial-wire be connected to an evaluation tool. For details of the connection method, refer to “CHAPTER 31 EXAMPLE OF SERIAL PROGRAMMING CONNECTION” in the hardware manual of the MB95310L/370L Series.

5. Pin Assignment

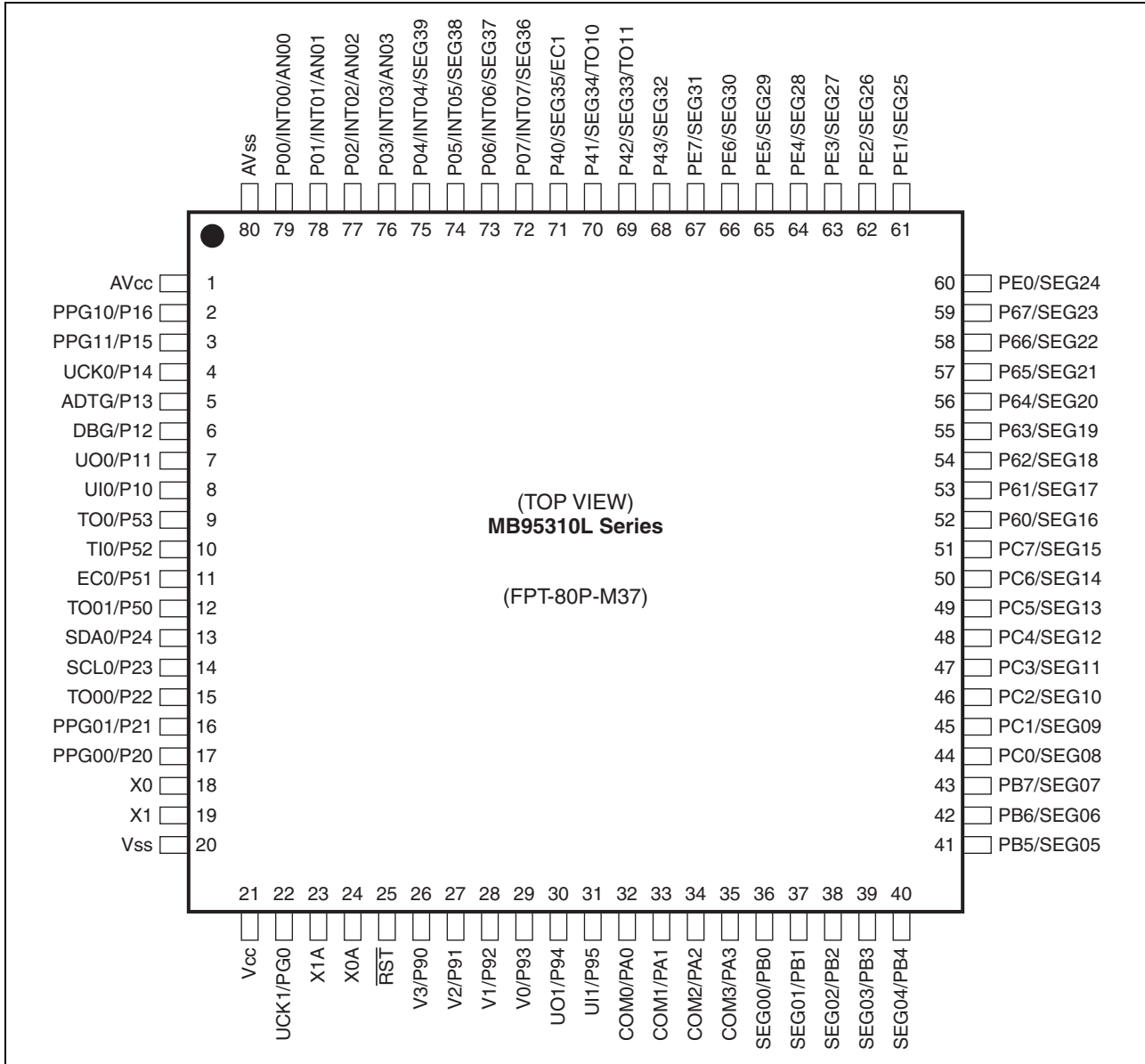

(Continued)

(Continued)

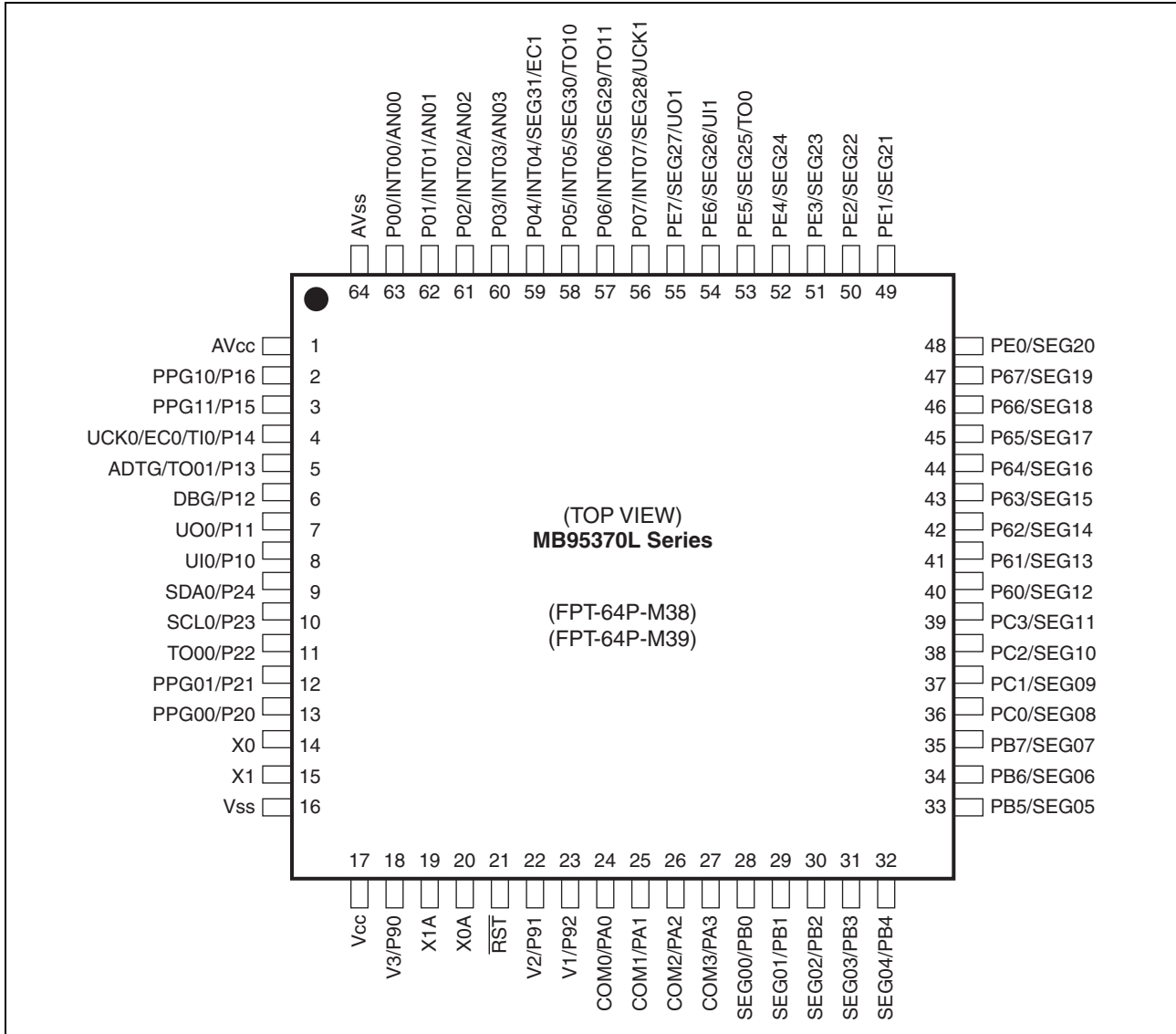

6. Pin Description (MB95310L Series)

Pin no.	Pin name	I/O circuit type*	Function
1	AV _{CC}	—	A/D converter power supply pin
2	P16	H	General-purpose I/O port
	PPG10		8/16-bit PPG ch. 1 output pin
3	P15	H	General-purpose I/O port
	PPG11		8/16-bit PPG ch. 1 output pin
4	P14	H	General-purpose I/O port
	UCK0		UART/SIO ch. 0 clock I/O pin
5	P13	H	General-purpose I/O port
	ADTG		A/D trigger input (ADTG) pin
6	P12	C	General-purpose I/O port
	DBG		DBG input pin
7	P11	H	General-purpose I/O port
	UO0		UART/SIO ch. 0 data output pin
8	P10	G	General-purpose I/O port
	UI0		UART/SIO ch. 0 data input pin
9	P53	H	General-purpose I/O port
	TO0		16-bit reload timer ch. 0 output pin
10	P52	H	General-purpose I/O port
	TI0		16-bit reload timer ch. 0 input pin The pin can also be used as the event counter input pin when the event counter function is used.
11	P51	H	General-purpose I/O port
	EC0		8/16-bit composite timer ch. 0 clock input pin
12	P50	H	General-purpose I/O port
	TO01		8/16-bit composite timer ch. 0 output pin
13	P24	I	General-purpose I/O port
	SDA0		I ² C data I/O pin
14	P23	I	General-purpose I/O port
	SCL0		I ² C clock I/O pin
15	P22	H	General-purpose I/O port
	TO00		8/16-bit composite timer ch. 0 output pin
16	P21	H	General-purpose I/O port
	PPG01		8/16-bit PPG ch. 0 output pin
17	P20	H	General-purpose I/O port
	PPG00		8/16-bit PPG ch. 0 output pin
18	X0	A	Main clock oscillation pin
19	X1	A	Main clock oscillation pin

(Continued)

Pin no.	Pin name	I/O circuit type*	Function
20	V _{SS}	—	Power supply pin (GND)
21	V _{CC}	—	Power supply pin
22	PG0	H	General-purpose I/O port
	UCK1		UART/SIO ch. 1 clock I/O pin
23	X1A	A	Subclock oscillation pin (32 kHz)
24	X0A	A	Subclock oscillation pin (32 kHz)
25	RST	B	Reset pin
26	P90	R	General-purpose I/O port
	V3		LCDC drive power supply pin
27	P91	R	General-purpose I/O port
	V2		LCDC drive power supply pin
28	P92	R	General-purpose I/O port
	V1		LCDC drive power supply pin
29	P93	R	General-purpose I/O port
	V0		LCDC drive power supply pin
30	P94	H	General-purpose I/O port
	UO1		UART/SIO ch. 0 data output pin
31	P95	G	General-purpose I/O port
	UI1		UART/SIO ch. 0 data input pin
32	PA0	M	General-purpose I/O port
	COM0		LCDC COM output pin
33	PA1	M	General-purpose I/O port
	COM1		LCDC COM output pin
34	PA2	M	General-purpose I/O port
	COM2		LCDC COM output pin
35	PA3	M	General-purpose I/O port
	COM3		LCDC COM output pin
36	PB0	M	General-purpose I/O port
	SEG00		LCDC SEG output pin
37	PB1	M	General-purpose I/O port
	SEG01		LCDC SEG output pin
38	PB2	M	General-purpose I/O port
	SEG02		LCDC SEG output pin
39	PB3	M	General-purpose I/O port
	SEG03		LCDC SEG output pin
40	PB4	M	General-purpose I/O port
	SEG04		LCDC SEG output pin

(Continued)

Pin no.	Pin name	I/O circuit type*	Function
41	PB5	M	General-purpose I/O port
	SEG05		LCDC SEG output pin
42	PB6	M	General-purpose I/O port
	SEG06		LCDC SEG output pin
43	PB7	M	General-purpose I/O port
	SEG07		LCDC SEG output pin
44	PC0	M	General-purpose I/O port
	SEG08		LCDC SEG output pin
45	PC1	M	General-purpose I/O port
	SEG09		LCDC SEG output pin
46	PC2	M	General-purpose I/O port
	SEG10		LCDC SEG output pin
47	PC3	M	General-purpose I/O port
	SEG11		LCDC SEG output pin
48	PC4	M	General-purpose I/O port
	SEG12		LCDC SEG output pin
49	PC5	M	General-purpose I/O port
	SEG13		LCDC SEG output pin
50	PC6	M	General-purpose I/O port
	SEG14		LCDC SEG output pin
51	PC7	M	General-purpose I/O port
	SEG15		LCDC SEG output pin
52	P60	M	General-purpose I/O port
	SEG16		LCDC SEG output pin
53	P61	M	General-purpose I/O port
	SEG17		LCDC SEG output pin
54	P62	M	General-purpose I/O port
	SEG18		LCDC SEG output pin
55	P63	M	General-purpose I/O port
	SEG19		LCDC SEG output pin
56	P64	M	General-purpose I/O port
	SEG20		LCDC SEG output pin
57	P65	M	General-purpose I/O port
	SEG21		LCDC SEG output pin
58	P66	M	General-purpose I/O port
	SEG22		LCDC SEG output pin

(Continued)

Pin no.	Pin name	I/O circuit type*	Function
59	P67	M	General-purpose I/O port
	SEG23		LCDC SEG output pin
60	PE0	M	General-purpose I/O port
	SEG24		LCDC SEG output pin
61	PE1	M	General-purpose I/O port
	SEG25		LCDC SEG output pin
62	PE2	M	General-purpose I/O port
	SEG26		LCDC SEG output pin
63	PE3	M	General-purpose I/O port
	SEG27		LCDC SEG output pin
64	PE4	M	General-purpose I/O port
	SEG28		LCDC SEG output pin
65	PE5	M	General-purpose I/O port
	SEG29		LCDC SEG output pin
66	PE6	N	General-purpose I/O port
	SEG30		LCDC SEG output pin
67	PE7	M	General-purpose I/O port
	SEG31		LCDC SEG output pin
68	P43	M	General-purpose I/O port
	SEG32		LCDC SEG output pin
69	P42	M	General-purpose I/O port
	SEG33		LCDC SEG output pin
	TO11		8/16-bit composite timer ch. 1 output pin
70	P41	M	General-purpose I/O port
	SEG34		LCDC SEG output pin
	TO10		8/16-bit composite timer ch. 1 output pin
71	P40	M	General-purpose I/O port
	SEG35		LCDC SEG output pin
	EC1		8/16-bit composite timer ch. 1 clock input pin
72	P07	Q	General-purpose I/O port
	INT07		External interrupt input pin
	SEG36		LCDC SEG output pin
73	P06	Q	General-purpose I/O port
	INT06		External interrupt input pin
	SEG37		LCDC SEG output pin

(Continued)

(Continued)

Pin no.	Pin name	I/O circuit type*	Function
74	P05	Q	General-purpose I/O port
	INT05		External interrupt input pin
	SEG38		LCDC SEG output pin
75	P04	Q	General-purpose I/O port
	INT04		External interrupt input pin
	SEG39		LCDC SEG output pin
76	P03	J	General-purpose I/O port
	INT03		External interrupt input pin
	AN03		A/D analog input pin
77	P02	J	General-purpose I/O port
	INT02		External interrupt input pin
	AN02		A/D analog input pin
78	P01	J	General-purpose I/O port
	INT01		External interrupt input pin
	AN01		A/D analog input pin
79	P00	J	General-purpose I/O port
	INT00		External interrupt input pin
	AN00		A/D analog input pin
80	AV _{SS}	—	A/D converter power supply pin (GND)

*: For the I/O circuit types, see “I/O Circuit Type”.

7. Pin Description (MB95370L Series)

Pin no.	Pin name	I/O circuit type*	Function
1	AV _{CC}	—	A/D converter power supply pin
2	P16	H	General-purpose I/O port
	PPG10		8/16-bit PPG ch. 1 output pin
3	P15	H	General-purpose I/O port
	PPG11		8/16-bit PPG ch. 1 output pin
4	P14	H	General-purpose I/O port
	UCK0		UART/SIO ch. 0 clock I/O pin
	EC0		8/16-bit composite timer ch. 0 clock input pin The pin can also be used as the event counter input pin when the event counter function is used.
	T10		16-bit reload timer ch. 0 input pin
5	P13	H	General-purpose I/O port
	ADTG		A/D trigger input (ADTG) pin
	TO01		8/16-bit composite timer ch. 0 output pin
6	P12	C	General-purpose I/O port
	DBG		DBG input pin
7	P11	H	General-purpose I/O port
	UO0		UART/SIO ch. 0 data output pin
8	P10	G	General-purpose I/O port
	UI0		UART/SIO ch. 0 data input pin
9	P24	I	General-purpose I/O port
	SDA0		I ² C data I/O pin
10	P23	I	General-purpose I/O port
	SCL0		I ² C clock I/O pin
11	P22	H	General-purpose I/O port
	TO00		8/16-bit composite timer ch. 0 output pin
12	P21	H	General-purpose I/O port
	PPG01		8/16-bit PPG ch. 0 output pin
13	P20	H	General-purpose I/O port
	PPG00		8/16-bit PPG ch. 0 output pin
14	X0	A	Main clock oscillation pin
15	X1	A	Main clock oscillation pin
16	V _{SS}	—	Power supply pin (GND)
17	V _{CC}	—	Power supply pin
18	P90	R	General-purpose I/O port
	V3		LCDC drive power supply pin

(Continued)

Pin no.	Pin name	I/O circuit type*	Function
19	X1A	A	Subclock oscillation pin (32 kHz)
20	X0A		Subclock oscillation pin (32 kHz)
21	\overline{RST}	B	Reset pin
22	P91	R	General-purpose I/O port
	V2		LCDC drive power supply pin
23	P92	R	General-purpose I/O port
	V1		LCDC drive power supply pin
24	PA0	M	General-purpose I/O port
	COM0		LCDC COM output pin
25	PA1	M	General-purpose I/O port
	COM1		LCDC COM output pin
26	PA2	M	General-purpose I/O port
	COM2		LCDC COM output pin
27	PA3	M	General-purpose I/O port
	COM3		LCDC COM output pin
28	PB0	M	General-purpose I/O port
	SEG00		LCDC SEG output pin
29	PB1	M	General-purpose I/O port
	SEG01		LCDC SEG output pin
30	PB2	M	General-purpose I/O port
	SEG02		LCDC SEG output pin
31	PB3	M	General-purpose I/O port
	SEG03		LCDC SEG output pin
32	PB4	M	General-purpose I/O port
	SEG04		LCDC SEG output pin
33	PB5	M	General-purpose I/O port
	SEG05		LCDC SEG output pin
34	PB6	M	General-purpose I/O port
	SEG06		LCDC SEG output pin
35	PB7	M	General-purpose I/O port
	SEG07		LCDC SEG output pin
36	PC0	M	General-purpose I/O port
	SEG08		LCDC SEG output pin
37	PC1	M	General-purpose I/O port
	SEG09		LCDC SEG output pin
38	PC2	M	General-purpose I/O port
	SEG10		LCDC SEG output pin

(Continued)

Pin no.	Pin name	I/O circuit type*	Function
39	PC3	M	General-purpose I/O port
	SEG11		LCDC SEG output pin
40	P60	M	General-purpose I/O port
	SEG12		LCDC SEG output pin
41	P61	M	General-purpose I/O port
	SEG13		LCDC SEG output pin
42	P62	M	General-purpose I/O port
	SEG14		LCDC SEG output pin
43	P63	M	General-purpose I/O port
	SEG15		LCDC SEG output pin
44	P64	M	General-purpose I/O port
	SEG16		LCDC SEG output pin
45	P65	M	General-purpose I/O port
	SEG17		LCDC SEG output pin
46	P66	M	General-purpose I/O port
	SEG18		LCDC SEG output pin
47	P67	M	General-purpose I/O port
	SEG19		LCDC SEG output pin
48	PE0	M	General-purpose I/O port
	SEG20		LCDC SEG output pin
49	PE1	M	General-purpose I/O port
	SEG21		LCDC SEG output pin
50	PE2	M	General-purpose I/O port
	SEG22		LCDC SEG output pin
51	PE3	M	General-purpose I/O port
	SEG23		LCDC SEG output pin
52	PE4	M	General-purpose I/O port
	SEG24		LCDC SEG output pin
53	PE5	M	General-purpose I/O port
	SEG25		LCDC SEG output pin
	TO0		16-bit reload timer ch. 0 output pin
54	PE6	N	General-purpose I/O port
	SEG26		LCDC SEG output pin
	UI1		UART/SIO ch. 1 data input pin
55	PE7	M	General-purpose I/O port
	SEG27		LCDC SEG output pin
	UO1		UART/SIO ch. 1 data output pin

(Continued)

(Continued)

Pin no.	Pin name	I/O circuit type*	Function
56	P07	Q	General-purpose I/O port
	INT07		External interrupt input pin
	SEG28		LCDC SEG output pin
	UCK1		UART/SIO ch. 1 clock I/O pin
57	P06	Q	General-purpose I/O port
	INT06		External interrupt input pin
	SEG29		LCDC SEG output pin
	TO11		8/16-bit composite timer ch. 1 output pin
58	P05	Q	General-purpose I/O port
	INT05		External interrupt input pin
	SEG30		LCDC SEG output pin
	TO10		8/16-bit composite timer ch. 1 output pin
59	P04	Q	General-purpose I/O port
	INT04		External interrupt input pin
	SEG31		LCDC SEG output pin
	EC1		8/16-bit composite timer ch. 1 clock input pin
60	P03	J	General-purpose I/O port
	INT03		External interrupt input pin
	AN03		A/D analog input pin
61	P02	J	General-purpose I/O port
	INT02		External interrupt input pin
	AN02		A/D analog input pin
62	P01	J	General-purpose I/O port
	INT01		External interrupt input pin
	AN01		A/D analog input pin
63	P00	J	General-purpose I/O port
	INT00		External interrupt input pin
	AN00		A/D analog input pin
64	AV _{SS}	—	A/D converter power supply pin (GND)

*: For the I/O circuit types, see "I/O Circuit Type".

8. I/O Circuit Type

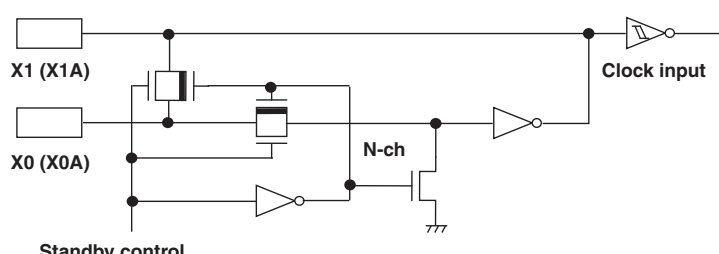
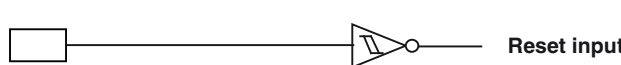
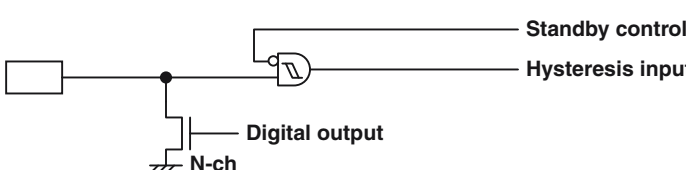
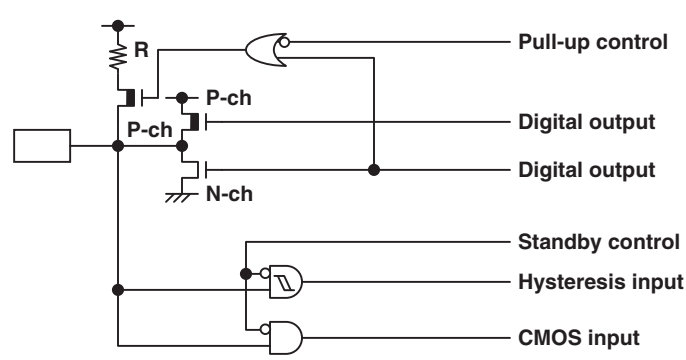
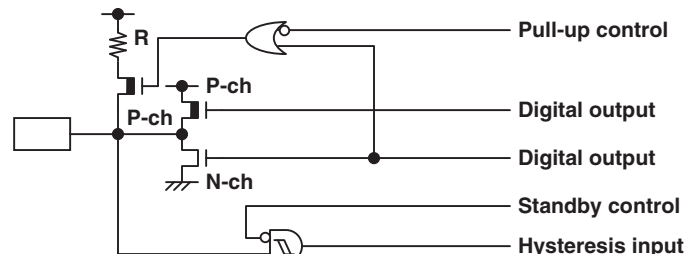
Type	Circuit	Remarks
A		<ul style="list-style-type: none"> ■ Oscillation circuit ■ High-speed side Feedback resistance: approx. 1 MΩ ■ Low-speed side Feedback resistance: approx: 24 MΩ Dumping resistance: approx: 144 kΩ
B		Reset input
C		<ul style="list-style-type: none"> ■ N-ch open drain output ■ Hysteresis input
G		<ul style="list-style-type: none"> ■ CMOS output ■ Hysteresis input ■ CMOS input ■ Pull-up control available
H		<ul style="list-style-type: none"> ■ CMOS output ■ Hysteresis input ■ Pull-up control available

(Continued)

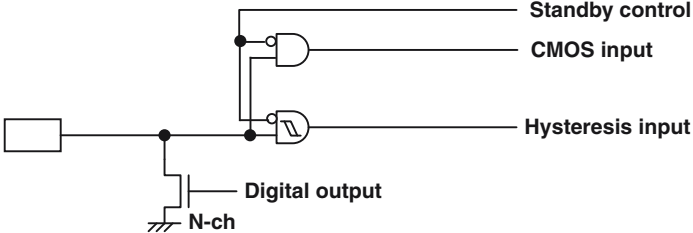
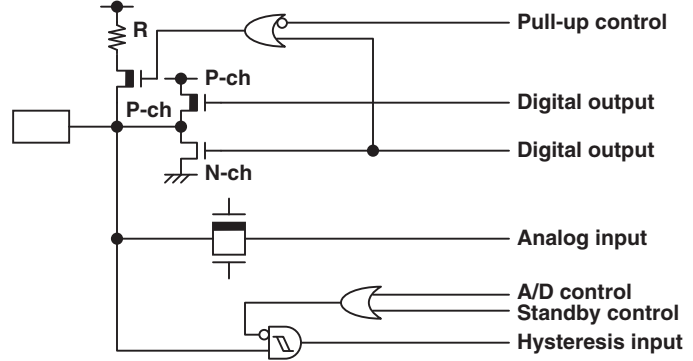
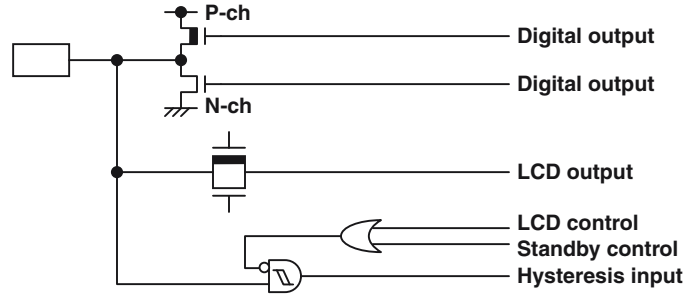
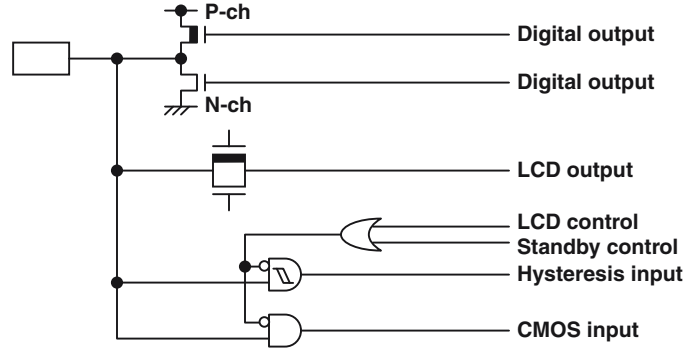
Type	Circuit	Remarks
I		<ul style="list-style-type: none"> ■ N-ch open drain output ■ CMOS input ■ Hysteresis input
J		<ul style="list-style-type: none"> ■ CMOS output ■ Hysteresis input ■ Analog input ■ Pull-up control available
M		<ul style="list-style-type: none"> ■ CMOS output ■ LCD output ■ Hysteresis input
N		<ul style="list-style-type: none"> ■ CMOS output ■ LCD output ■ Hysteresis input ■ CMOS input

(Continued)

(Continued)

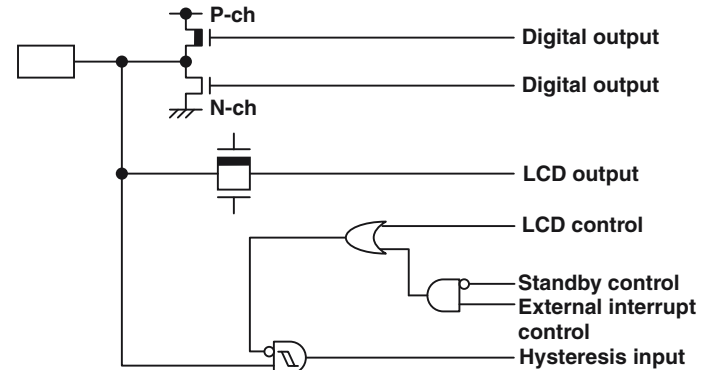
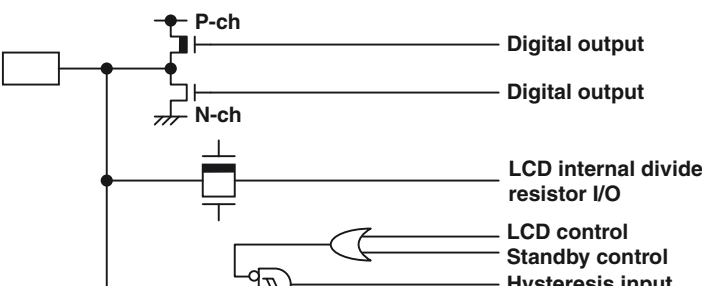
Type	Circuit	Remarks
Q		<ul style="list-style-type: none"> ■ CMOS output ■ LCD output ■ Hysteresis input
R		<ul style="list-style-type: none"> ■ CMOS output ■ LCD power supply ■ Hysteresis input

9. Notes On Device Handling

■ Preventing latch-ups

When using the device, ensure that the voltage applied does not exceed the maximum voltage rating.

In a CMOS IC, if a voltage higher than V_{CC} or a voltage lower than V_{SS} is applied to an input/output pin that is neither a medium-withstand voltage pin nor a high-withstand voltage pin, or if a voltage out of the rating range of power supply voltage mentioned in "18.1 Absolute Maximum Ratings" of "Electrical Characteristics" is applied to the V_{CC} pin or the V_{SS} pin, a latch-up may occur.

When a latch-up occurs, power supply current increases significantly, which may cause a component to be thermally destroyed.

■ Stabilizing supply voltage

Supply voltage must be stabilized.

A malfunction may occur when power supply voltage fluctuates rapidly even though the fluctuation is within the guaranteed operating range of the V_{CC} power supply voltage.

As a rule of voltage stabilization, suppress voltage fluctuation so that the fluctuation in V_{CC} ripple (p-p value) at the commercial frequency (50 Hz/60 Hz) does not exceed 10% of the standard V_{CC} value, and the transient fluctuation rate does not exceed 0.1 V/ms at a momentary fluctuation such as switching the power supply.

■ Notes on using the external clock

When an external clock is used, oscillation stabilization wait time is required for power-on reset, wake-up from subclock mode or stop mode.

10. Pin Connection

■ Treatment of unused input pins

If an unused input pin is left unconnected, a component may be permanently damaged due to malfunctions or latch-ups. Always pull up or pull down an unused input pin through a resistor of at least $2\text{ k}\Omega$. Set an unused input/output pin to the output state and leave it unconnected, or set it to the input state and treat it the same as an unused input pin. If there is an unused output pin, leave it unconnected.

■ Notes on handling the external clock pins while using the CR clock

Connect the X0 pin and the X0A pin to the V_{SS} pin and leave the X1 pin and the X1A pin unconnected.

■ Power supply pins

To reduce unnecessary electro-magnetic emission, prevent malfunctions of strobe signals due to an increase in the ground level, and conform to the total output current standard, always connect the V_{CC} pin and the V_{SS} pin to the power supply and ground outside the device. In addition, connect the current supply source to the V_{CC} pin and the V_{SS} pin with low impedance.

It is also advisable to connect a ceramic capacitor of approximately $0.1\ \mu\text{F}$ as a bypass capacitor between the V_{CC} pin and the V_{SS} pin at a location close to this device.

■ DBG pin

Connect the DBG pin directly to an external pull-up resistor.

To prevent the device from unintentionally entering the debug mode due to noise, minimize the distance between the DBG pin and the V_{CC} or V_{SS} pin when designing the layout of the printed circuit board.

The DBG pin should not stay at "L" level after power-on until the reset output is released.

■ $\overline{\text{RST}}$ pin

Connect the $\overline{\text{RST}}$ pin directly to an external pull-up resistor.

To prevent the device from unintentionally entering the reset mode due to noise, minimize the distance between the $\overline{\text{RST}}$ pin and the V_{CC} or V_{SS} pin when designing the layout of the printed circuit board.

- DBG/ $\overline{\text{RST}}$ pins connection diagram

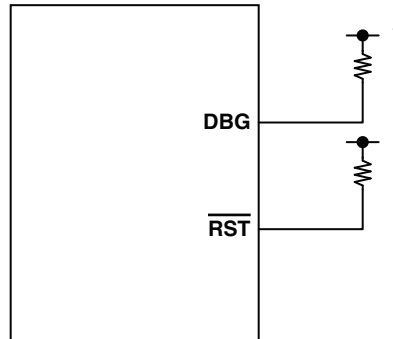

*: Since the DBG input pin becomes a communication pin in on-chip debug mode, set a pull-up resistor value suiting the input/output specifications of P12/DBG.

11. Recommended Layout

- GND wire should be placed around X0, X1, X0A and X1A

The recommended layout method illustrated in following diagram aims to avoid noise coupled between the oscillator pins and GPIO, which may cause the main oscillator or the sub oscillator to malfunction.

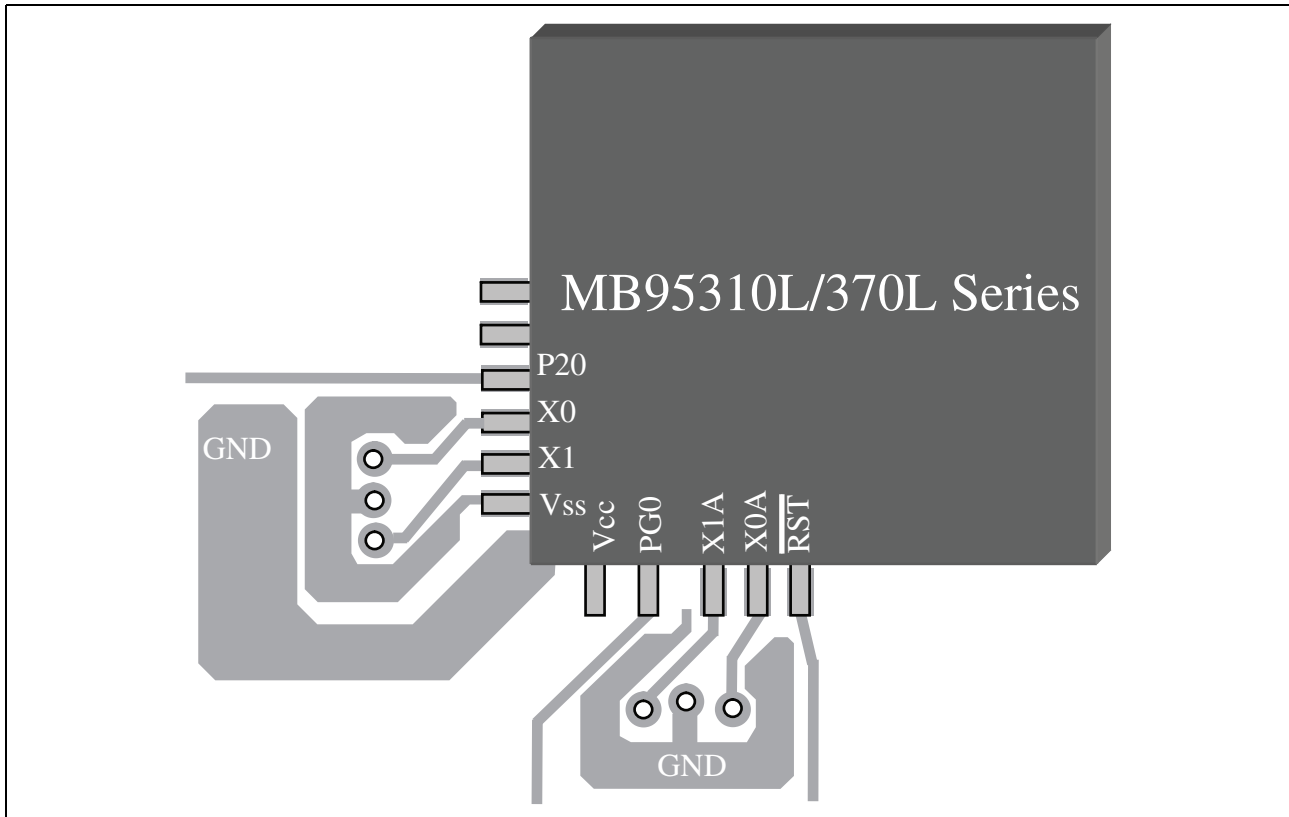

12. Block Diagram (MB95310L Series)

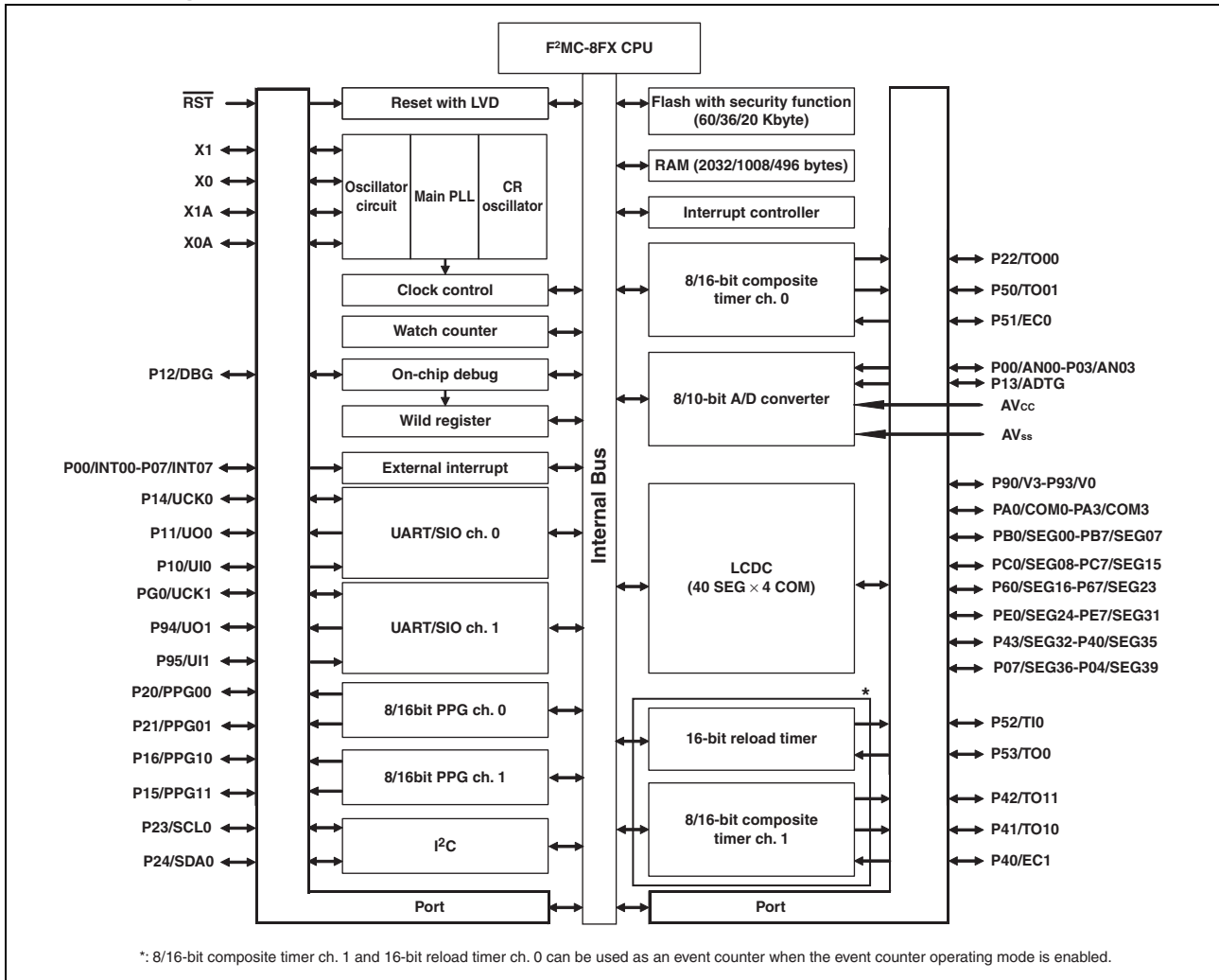

13. Block Diagram (MB95370L Series)

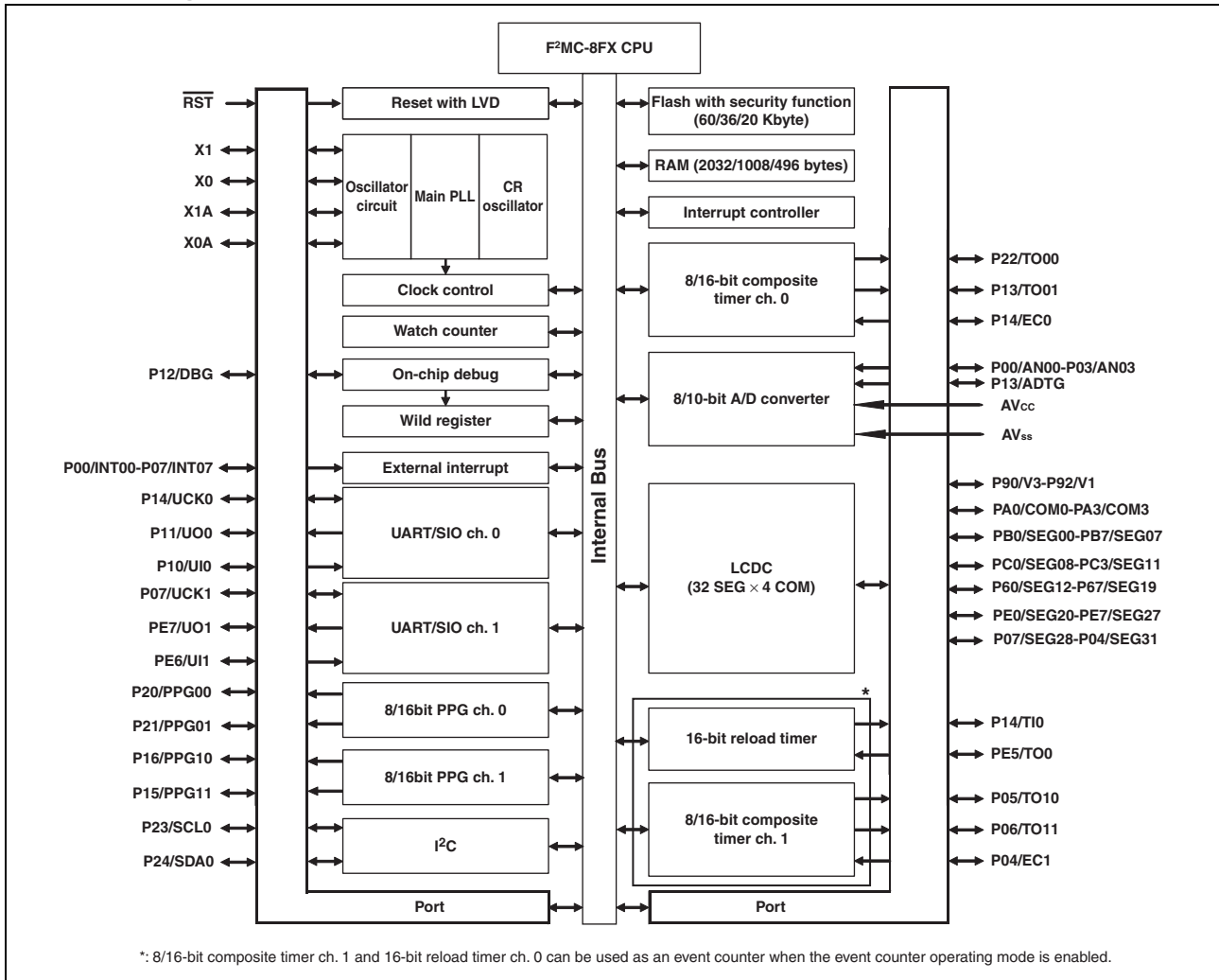

14. CPU Core

■ Memory Space

The memory space of the MB95310L/370L Series is 64 Kbyte in size, and consists of an I/O area, a data area, and a program area. The memory space includes areas intended for specific purposes such as general-purpose registers and a vector table. The memory maps of the MB95310L/370L Series are shown below.

■ Memory Maps

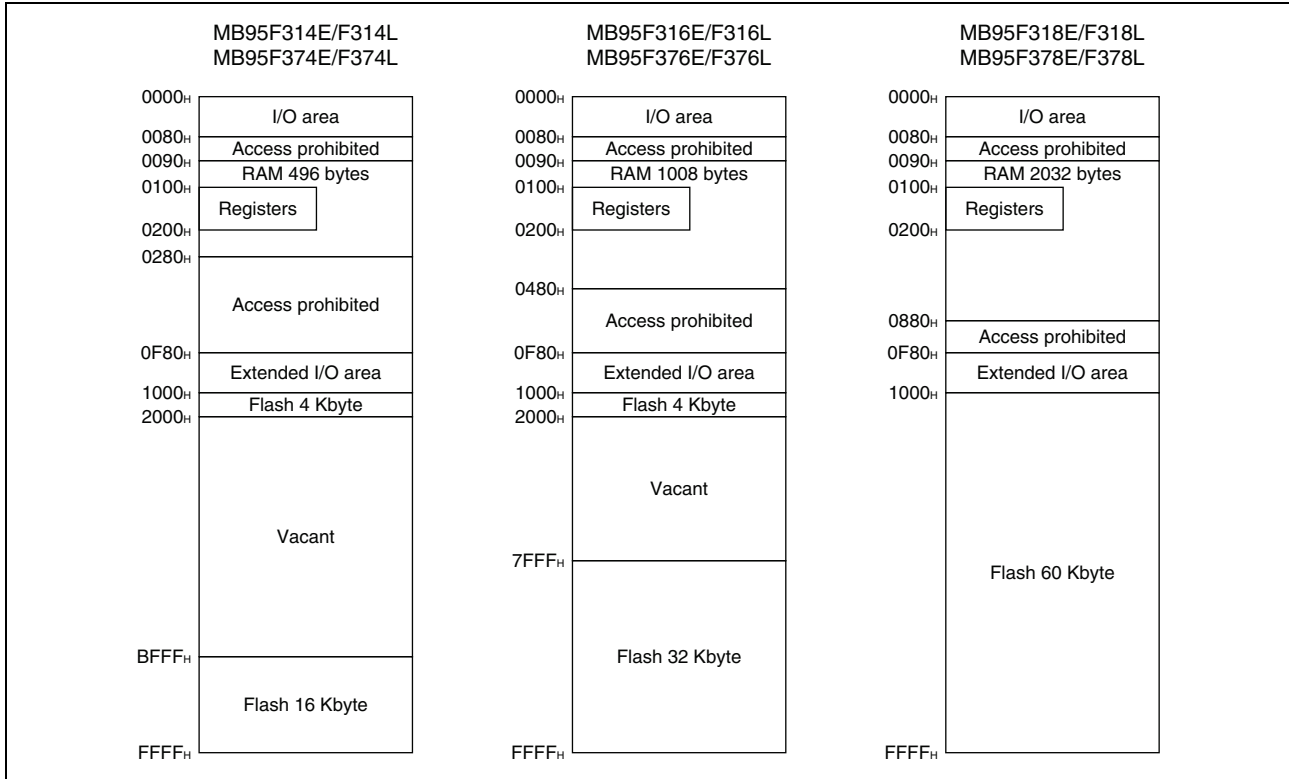

15. I/O Map (MB95310L Series)

Address	Register abbreviation	Register name	R/W	Initial value
0000 _H	PDR0	Port 0 data register	R/W	00000000 _B
0001 _H	DDR0	Port 0 direction register	R/W	00000000 _B
0002 _H	PDR1	Port 1 data register	R/W	00000000 _B
0003 _H	DDR1	Port 1 direction register	R/W	00000000 _B
0004 _H	—	(Disabled)	—	—
0005 _H	WATR	Oscillation stabilization wait time setting register	R/W	11111111 _B
0006 _H	PLLC	PLL control register	R/W	00000000 _B
0007 _H	SYCC	System clock control register	R/W	XXXXXXXX11 _B
0008 _H	STBC	Standby control register	R/W	00000XXX _B
0009 _H	RSRR	Reset source register	R/W	000XXXXX _B
000A _H	TBTC	Time-base timer control register	R/W	00000000 _B
000B _H	WPCR	Watch prescaler control register	R/W	00000000 _B
000C _H	WDTC	Watchdog timer control register	R/W	00000000 _B
000D _H	SYCC2	System clock control register 2	R/W	XX100011 _B
000E _H	PDR2	Port 2 data register	R/W	00000000 _B
000F _H	DDR2	Port 2 direction register	R/W	00000000 _B
0010 _H , 0011 _H	—	(Disabled)	—	—
0012 _H	PDR4	Port 4 data register	R/W	00000000 _B
0013 _H	DDR4	Port 4 direction register	R/W	00000000 _B
0014 _H	PDR5	Port 5 data register	R/W	00000000 _B
0015 _H	DDR5	Port 5 direction register	R/W	00000000 _B
0016 _H	PDR6	Port 6 data register	R/W	00000000 _B
0017 _H	DDR6	Port 6 direction register	R/W	00000000 _B
0018 _H to 001B _H	—	(Disabled)	—	—
001C _H	PDR9	Port 9 data register	R/W	00000000 _B
001D _H	DDR9	Port 9 direction register	R/W	00000000 _B
001E _H	PDRA	Port A data register	R/W	00000000 _B
001F _H	DDRA	Port A direction register	R/W	00000000 _B
0020 _H	PDRB	Port B data register	R/W	00000000 _B
0021 _H	DDRB	Port B direction register	R/W	00000000 _B
0022 _H	PDRC	Port C data register	R/W	00000000 _B
0023 _H	DDRC	Port C direction register	R/W	00000000 _B
0024 _H , 0025 _H	—	(Disabled)	—	—

(Continued)

Address	Register abbreviation	Register name	R/W	Initial value
0026 _H	PDRE	Port E data register	R/W	00000000 _B
0027 _H	DDRE	Port E direction register	R/W	00000000 _B
0028 _H , 0029 _H	—	(Disabled)	—	—
002A _H	PDRG	Port G data register	R/W	00000000 _B
002B _H	DDRG	Port G direction register	R/W	00000000 _B
002C _H	PUL0	Port 0 pull-up register	R/W	00000000 _B
002D _H	PUL1	Port 1 pull-up register	R/W	00000000 _B
002E _H	PUL2	Port 2 pull-up register	R/W	00000000 _B
002F _H , 0030 _H	—	(Disabled)	—	—
0031 _H	PUL5	Port 5 pull-up register	R/W	00000000 _B
0032 _H , 0033 _H	—	(Disabled)	—	—
0034 _H	PUL9	Port 9 pull-up register	R/W	00000000 _B
0035 _H	PULG	Port G pull-up register	R/W	00000000 _B
0036 _H	T01CR1	8/16-bit composite timer 01 status control register 1 ch. 0	R/W	00000000 _B
0037 _H	T00CR1	8/16-bit composite timer 00 status control register 1 ch. 0	R/W	00000000 _B
0038 _H	T11CR1	8/16-bit composite timer 11 status control register 1 ch. 1	R/W	00000000 _B
0039 _H	T10CR1	8/16-bit composite timer 10 status control register 1 ch. 1	R/W	00000000 _B
003A _H	PC01	8/16-bit PPG01 control register ch. 0	R/W	00000000 _B
003B _H	PC00	8/16-bit PPG00 control register ch. 0	R/W	00000000 _B
003C _H	PC11	8/16-bit PPG11 control register ch. 1	R/W	00000000 _B
003D _H	PC10	8/16-bit PPG10 control register ch. 1	R/W	00000000 _B
003E _H	TMCSRH	16-bit reload timer control status register upper ch. 0	R/W	00000000 _B
003F _H	TMCSRL	16-bit reload timer control status register lower ch. 0	R/W	00000000 _B
0040 _H to 0047 _H	—	(Disabled)	—	—
0048 _H	EIC00	External interrupt circuit control register ch. 0/ch. 1	R/W	00000000 _B
0049 _H	EIC10	External interrupt circuit control register ch. 2/ch. 3	R/W	00000000 _B
004A _H	EIC20	External interrupt circuit control register ch. 4/ch. 5	R/W	00000000 _B
004B _H	EIC30	External interrupt circuit control register ch. 6/ch. 7	R/W	00000000 _B
004C _H , 004D _H	—	(Disabled)	—	—
004E _H	LVDR	LVD reset voltage selection ID register	R/W	00000000 _B
004F _H	LVDC	LVD control register	R/W	X000000X _B
0050 _H to 0055 _H	—	(Disabled)	—	—

(Continued)

Address	Register abbreviation	Register name	R/W	Initial value
0056 _H	SMC10	UART/SIO serial mode control register 1 ch. 0	R/W	00000000 _B
0057 _H	SMC20	UART/SIO serial mode control register 2 ch. 0	R/W	00100000 _B
0058 _H	SSR0	UART/SIO serial status register ch. 0	R/W	00000001 _B
0059 _H	TDR0	UART/SIO output data register ch. 0	R/W	00000000 _B
005A _H	RDR0	UART/SIO input data register ch. 0	R	00000000 _B
005B _H	SMC11	UART/SIO serial mode control register 1 ch. 1	R/W	00000000 _B
005C _H	SMC21	UART/SIO serial mode control register 2 ch. 1	R/W	00100000 _B
005D _H	SSR1	UART/SIO serial status register ch. 1	R/W	00000001 _B
005E _H	TDR1	UART/SIO output data register ch. 1	R/W	00000000 _B
005F _H	RDR1	UART/SIO input data register ch. 1	R	00000000 _B
0060 _H	IBCR00	I ² C bus control register 0	R/W	00000001 _B
0061 _H	IBCR10	I ² C bus control register 1	R/W	00000000 _B
0062 _H	IBCR0	I ² C bus status register	R	00000000 _B
0063 _H	IDDR0	I ² C data register	R/W	00000000 _B
0064 _H	IAAR0	I ² C address register	R/W	00000000 _B
0065 _H	ICCR0	I ² C clock control register	R/W	00000000 _B
0066 _H to 006B _H	—	(Disabled)	—	—
006C _H	ADC1	8/10-bit A/D converter control register 1	R/W	00000000 _B
006D _H	ADC2	8/10-bit A/D converter control register 2	R/W	00000000 _B
006E _H	ADDH	8/10-bit A/D converter data register upper	R/W	00000000 _B
006F _H	ADDL	8/10-bit A/D converter data register lower	R/W	00000000 _B
0070 _H	WCSR	Watch counter status register	R/W	00000000 _B
0071 _H	FSR2	Flash memory status register 2	R/W	00000000 _B
0072 _H	FSR	Flash memory status register	R/W	000X0000 _B
0073 _H	SWRE0	Flash memory sector write control register 0	R/W	00000000 _B
0074 _H	FSR3	Flash memory status register 3	R	00000000 _B
0075 _H	—	(Disabled)	—	—
0076 _H	WREN	Wild register address compare enable register	R/W	00000000 _B
0077 _H	WROR	Wild register data test setting register	R/W	00000000 _B
0078 _H	—	Mirror of register bank pointer (RP) and direct bank pointer (DP)	—	—

(Continued)

Address	Register abbreviation	Register name	R/W	Initial value
0079 _H	ILR0	Interrupt level setting register 0	R/W	11111111 _B
007A _H	ILR1	Interrupt level setting register 1	R/W	11111111 _B
007B _H	ILR2	Interrupt level setting register 2	R/W	11111111 _B
007C _H	ILR3	Interrupt level setting register 3	R/W	11111111 _B
007D _H	ILR4	Interrupt level setting register 4	R/W	11111111 _B
007E _H	ILR5	Interrupt level setting register 5	R/W	11111111 _B
007F _H	—	(Disabled)	—	—
0F80 _H	WRARH0	Wild register address setting register (upper) ch. 0	R/W	00000000 _B
0F81 _H	WRARL0	Wild register address setting register (lower) ch. 0	R/W	00000000 _B
0F82 _H	WRDR0	Wild register data setting register ch. 0	R/W	00000000 _B
0F83 _H	WRARH1	Wild register address setting register (upper) ch. 1	R/W	00000000 _B
0F84 _H	WRARL1	Wild register address setting register (lower) ch. 1	R/W	00000000 _B
0F85 _H	WRDR1	Wild register data setting register ch. 1	R/W	00000000 _B
0F86 _H	WRARH2	Wild register address setting register (upper) ch. 2	R/W	00000000 _B
0F87 _H	WRARL2	Wild register address setting register (lower) ch. 2	R/W	00000000 _B
0F88 _H	WRDR2	Wild register data setting register ch. 2	R/W	00000000 _B
0F89 _H to 0F91 _H	—	(Disabled)	—	—
0F92 _H	T01CR0	8/16-bit composite timer 01 status control register 0 ch. 0	R/W	00000000 _B
0F93 _H	T00CR0	8/16-bit composite timer 00 status control register 0 ch. 0	R/W	00000000 _B
0F94 _H	T01DR	8/16-bit composite timer 01 data register ch. 0	R/W	00000000 _B
0F95 _H	T00DR	8/16-bit composite timer 00 data register ch. 0	R/W	00000000 _B
0F96 _H	TMCR0	8/16-bit composite timer 00/01 timer mode control register ch. 0	R/W	00000000 _B
0F97 _H	T11CR0	8/16-bit composite timer 11 status control register 0 ch. 1	R/W	00000000 _B
0F98 _H	T10CR0	8/16-bit composite timer 10 status control register 0 ch. 1	R/W	00000000 _B
0F99 _H	T11DR	8/16-bit composite timer 11 data register ch. 1	R/W	00000000 _B
0F9A _H	T10DR	8/16-bit composite timer 10 data register ch. 1	R/W	00000000 _B
0F9B _H	TMCR1	8/16-bit composite timer 10/11 timer mode control register ch. 1	R/W	00000000 _B
0F9C _H	PPS01	8/16-bit PPG01 cycle setting buffer register ch. 0	R/W	11111111 _B
0F9D _H	PPS00	8/16-bit PPG00 cycle setting buffer register ch. 0	R/W	11111111 _B
0F9E _H	PDS01	8/16-bit PPG01 duty setting buffer register ch. 0	R/W	11111111 _B
0F9F _H	PDS00	8/16-bit PPG00 duty setting buffer register ch. 0	R/W	11111111 _B
0FA0 _H	PPS11	8/16-bit PPG11 cycle setting buffer register ch. 1	R/W	11111111 _B
0FA1 _H	PPS10	8/16-bit PPG10 cycle setting buffer register ch. 1	R/W	11111111 _B
0FA2 _H	PDS11	8/16-bit PPG11 duty setting buffer register ch. 1	R/W	11111111 _B
0FA3 _H	PDS10	8/16-bit PPG10 duty setting buffer register ch. 1	R/W	11111111 _B

(Continued)

Address	Register abbreviation	Register name	R/W	Initial value
0FA4 _H	PPGS	8/16-bit PPG start register	R/W	00000000 _B
0FA5 _H	REVC	8/16-bit PPG output inversion register	R/W	00000000 _B
0FA6 _H	TMRH0	16-bit reload timer timer register upper	R/W	00000000 _B
	TMRLRH0	16-bit reload timer reload register upper	R/W	00000000 _B
0FA7 _H	TMRL0	16-bit reload timer timer register lower	R/W	00000000 _B
	TMRLRL0	16-bit reload timer reload register lower	R/W	00000000 _B
0FA8 _H to 0FBD _H	—	(Disabled)	—	—
0FBE _H	PSSR0	UART/SIO dedicated baud rate generator prescaler selecting register ch. 0	R/W	00000000 _B
0FBF _H	BRSR0	UART/SIO dedicated baud rate generator baud rate setting register ch. 0	R/W	00000000 _B
0FC0 _H	PSSR1	UART/SIO dedicated baud rate generator prescaler selecting register ch. 1	R/W	00000000 _B
0FC1 _H	BRSR1	UART/SIO dedicated baud rate generator baud rate setting register ch. 1	R/W	00000000 _B
0FC2 _H	—	(Disabled)	—	—
0FC3 _H	AIDRL	A/D input disable register (lower)	R/W	00000000 _B
0FC4 _H	LCDC	LCDC control register	R/W	00010000 _B
0FC5 _H	LCDCE1	LCDC enable register 1	R/W	00110000 _B
0FC6 _H	LCDCE2	LCDC enable register 2	R/W	00000000 _B
0FC7 _H	LCDCE3	LCDC enable register 3	R/W	00000000 _B
0FC8 _H	LCDCE4	LCDC enable register 4	R/W	00000000 _B
0FC9 _H	LCDCE5	LCDC enable register 5	R/W	00000000 _B
0FCA _H	LCDCE6	LCDC enable register 6	R/W	00000000 _B
0FCB _H	LCDCB1	LCDC blinking setting register 1	R/W	00000000 _B
0FCC _H	LCDCB2	LCDC blinking setting register 2	R/W	00000000 _B
0FCD _H to 0FE0 _H	LCDRAM	LCDC display RAM	R/W	00000000 _B
0FE1 _H	—	(Disabled)	—	—
0FE2 _H	EVCR	Event counter control register	R/W	00000000 _B
0FE3 _H	WCDR	Watch counter data register	R/W	00111111 _B
0FE4 _H	CRTH	Main CR clock trimming register (upper)	R/W	0XXXXXXXX _B
0FE5 _H	CRTL	Main CR clock trimming register (lower)	R/W	00XXXXXXXX _B
0FE6 _H to 0FE8 _H	—	(Disabled)	—	—
0FE9 _H	CMCR	Clock monitoring control register	R/W	XX000000 _B
0FEA _H	CMDR	Clock monitoring data register	R	00000000 _B

(Continued)

(Continued)

Address	Register abbreviation	Register name	R/W	Initial value
0FEB _H	WDTH	Watchdog timer selection ID register (upper)	R	XXXXXXXX _B
0FEC _H	WDTL	Watchdog timer selection ID register (lower)	R	XXXXXXXX _B
0FED _H	—	(Disabled)	—	—
0FEE _H	ILSR	Input level select register	R/W	0000000 _B
0FEF _H	WICR	Interrupt pin control register	R/W	0100000 _B
0FF0 _H to 0FFF _H	—	(Disabled)	—	—

■ R/W access symbols

R/W : Readable / Writable

R : Read only

■ Initial value symbols

0 : The initial value of this bit is "0".

1 : The initial value of this bit is "1".

X : The initial value of this bit is indeterminate.

Note: Do not write to an address that is "(Disabled)". If a "(Disabled)" address is read, an indeterminate value is returned.

16. I/O Map (MB95370L Series)

Address	Register abbreviation	Register name	R/W	Initial value
0000 _H	PDR0	Port 0 data register	R/W	00000000 _B
0001 _H	DDR0	Port 0 direction register	R/W	00000000 _B
0002 _H	PDR1	Port 1 data register	R/W	00000000 _B
0003 _H	DDR1	Port 1 direction register	R/W	00000000 _B
0004 _H	—	(Disabled)	—	—
0005 _H	WATR	Oscillation stabilization wait time setting register	R/W	11111111 _B
0006 _H	PLLC	PLL control register	R/W	00000000 _B
0007 _H	SYCC	System clock control register	R/W	XXXXXXXX11 _B
0008 _H	STBC	Standby control register	R/W	00000XXX _B
0009 _H	RSRR	Reset source register	R/W	000XXXXX _B
000A _H	TBTC	Time-base timer control register	R/W	00000000 _B
000B _H	WPCR	Watch prescaler control register	R/W	00000000 _B
000C _H	WDTC	Watchdog timer control register	R/W	00000000 _B
000D _H	SYCC2	System clock control register 2	R/W	XX100011 _B
000E _H	PDR2	Port 2 data register	R/W	00000000 _B
000F _H	DDR2	Port 2 direction register	R/W	00000000 _B
0010 _H to 0015 _H	—	(Disabled)	—	—
0016 _H	PDR6	Port 6 data register	R/W	00000000 _B
0017 _H	DDR6	Port 6 direction register	R/W	00000000 _B
0018 _H to 001B _H	—	(Disabled)	—	—
001C _H	PDR9	Port 9 data register	R/W	00000000 _B
001D _H	DDR9	Port 9 direction register	R/W	00000000 _B
001E _H	PDRA	Port A data register	R/W	00000000 _B
001F _H	DDRA	Port A direction register	R/W	00000000 _B
0020 _H	PDRB	Port B data register	R/W	00000000 _B
0021 _H	DDRB	Port B direction register	R/W	00000000 _B
0022 _H	PDRC	Port C data register	R/W	00000000 _B
0023 _H	DDRC	Port C direction register	R/W	00000000 _B
0024 _H , 0025 _H	—	(Disabled)	—	—
0026 _H	PDRE	Port E data register	R/W	00000000 _B
0027 _H	DDRE	Port E direction register	R/W	00000000 _B
0028 _H to 002B _H	—	(Disabled)	—	—
002C _H	PUL0	Port 0 pull-up register	R/W	00000000 _B
002D _H	PUL1	Port 1 pull-up register	R/W	00000000 _B
002E _H	PUL2	Port 2 pull-up register	R/W	00000000 _B

(Continued)

Address	Register abbreviation	Register name	R/W	Initial value
002F _H to 0033 _H	—	(Disabled)	—	—
0034 _H	PUL9	Port 9 pull-up register	R/W	00000000 _B
0035 _H	—	(Disabled)	—	—
0036 _H	T01CR1	8/16-bit composite timer 01 status control register 1 ch. 0	R/W	00000000 _B
0037 _H	T00CR1	8/16-bit composite timer 00 status control register 1 ch. 0	R/W	00000000 _B
0038 _H	T11CR1	8/16-bit composite timer 11 status control register 1 ch. 1	R/W	00000000 _B
0039 _H	T10CR1	8/16-bit composite timer 10 status control register 1 ch. 1	R/W	00000000 _B
003A _H	PC01	8/16-bit PPG01 control register ch. 0	R/W	00000000 _B
003B _H	PC00	8/16-bit PPG00 control register ch. 0	R/W	00000000 _B
003C _H	PC11	8/16-bit PPG11 control register ch. 1	R/W	00000000 _B
003D _H	PC10	8/16-bit PPG10 control register ch. 1	R/W	00000000 _B
003E _H	TMCSRH	16-bit reload timer control status register upper ch. 0	R/W	00000000 _B
003F _H	TMCSSL	16-bit reload timer control status register lower ch. 0	R/W	00000000 _B
0040 _H to 0047 _H	—	(Disabled)	—	—
0048 _H	EIC00	External interrupt circuit control register ch. 0/ch. 1	R/W	00000000 _B
0049 _H	EIC10	External interrupt circuit control register ch. 2/ch. 3	R/W	00000000 _B
004A _H	EIC20	External interrupt circuit control register ch. 4/ch. 5	R/W	00000000 _B
004B _H	EIC30	External interrupt circuit control register ch. 6/ch. 7	R/W	00000000 _B
004C _H , 004D _H	—	(Disabled)	—	—
004E _H	LVDR	LVD reset voltage selection ID register	R/W	00000000 _B
004F _H	LVDC	LVD control register	R/W	X000000X _B
0050 _H to 0055 _H	—	(Disabled)	—	—
0056 _H	SMC10	UART/SIO serial mode control register 1 ch. 0	R/W	00000000 _B
0057 _H	SMC20	UART/SIO serial mode control register 2 ch. 0	R/W	00100000 _B
0058 _H	SSR0	UART/SIO serial status register ch. 0	R/W	00000001 _B
0059 _H	TDR0	UART/SIO output data register ch. 0	R/W	00000000 _B
005A _H	RDR0	UART/SIO input data register ch. 0	R	00000000 _B
005B _H	SMC11	UART/SIO serial mode control register 1 ch. 1	R/W	00000000 _B
005C _H	SMC21	UART/SIO serial mode control register 2 ch. 1	R/W	00100000 _B
005D _H	SSR1	UART/SIO serial status register ch. 1	R/W	00000001 _B
005E _H	TDR1	UART/SIO output data register ch. 1	R/W	00000000 _B
005F _H	RDR1	UART/SIO input data register ch. 1	R	00000000 _B

(Continued)

Address	Register abbreviation	Register name	R/W	Initial value
0060 _H	IBCR00	I ² C bus control register 0	R/W	00000001 _B
0061 _H	IBCR10	I ² C bus control register 1	R/W	00000000 _B
0062 _H	IBCR0	I ² C bus status register	R	00000000 _B
0063 _H	IDDR0	I ² C data register	R/W	00000000 _B
0064 _H	IAAR0	I ² C address register	R/W	00000000 _B
0065 _H	ICCR0	I ² C clock control register	R/W	00000000 _B
0066 _H to 006B _H	—	(Disabled)	—	—
006C _H	ADC1	8/10-bit A/D converter control register 1	R/W	00000000 _B
006D _H	ADC2	8/10-bit A/D converter control register 2	R/W	00000000 _B
006E _H	ADDH	8/10-bit A/D converter data register upper	R/W	00000000 _B
006F _H	ADDL	8/10-bit A/D converter data register lower	R/W	00000000 _B
0070 _H	WCSR	Watch counter status register	R/W	00000000 _B
0071 _H	FSR2	Flash memory status register 2	R/W	00000000 _B
0072 _H	FSR	Flash memory status register	R/W	000X0000 _B
0073 _H	SWRE0	Flash memory sector write control register 0	R/W	00000000 _B
0074 _H	FSR3	Flash memory status register 3	R	00000000 _B
0075 _H	—	(Disabled)	—	—
0076 _H	WREN	Wild register address compare enable register	R/W	00000000 _B
0077 _H	WROR	Wild register data test setting register	R/W	00000000 _B
0078 _H	—	Mirror of register bank pointer (RP) and direct bank pointer (DP)	—	—
0079 _H	ILR0	Interrupt level setting register 0	R/W	11111111 _B
007A _H	ILR1	Interrupt level setting register 1	R/W	11111111 _B
007B _H	ILR2	Interrupt level setting register 2	R/W	11111111 _B
007C _H	ILR3	Interrupt level setting register 3	R/W	11111111 _B
007D _H	ILR4	Interrupt level setting register 4	R/W	11111111 _B
007E _H	ILR5	Interrupt level setting register 5	R/W	11111111 _B
007F _H	—	(Disabled)	—	—
0F80 _H	WRARH0	Wild register address setting register (upper) ch. 0	R/W	00000000 _B
0F81 _H	WRARL0	Wild register address setting register (lower) ch. 0	R/W	00000000 _B
0F82 _H	WRDR0	Wild register data setting register ch. 0	R/W	00000000 _B
0F83 _H	WRARH1	Wild register address setting register (upper) ch. 1	R/W	00000000 _B
0F84 _H	WRARL1	Wild register address setting register (lower) ch. 1	R/W	00000000 _B
0F85 _H	WRDR1	Wild register data setting register ch. 1	R/W	00000000 _B
0F86 _H	WRARH2	Wild register address setting register (upper) ch. 2	R/W	00000000 _B
0F87 _H	WRARL2	Wild register address setting register (lower) ch. 2	R/W	00000000 _B
0F88 _H	WRDR2	Wild register data setting register ch. 2	R/W	00000000 _B

(Continued)

Address	Register abbreviation	Register name	R/W	Initial value
0F89 _H to 0F91 _H	—	(Disabled)	—	—
0F92 _H	T01CR0	8/16-bit composite timer 01 status control register 0 ch. 0	R/W	00000000 _B
0F93 _H	T00CR0	8/16-bit composite timer 00 status control register 0 ch. 0	R/W	00000000 _B
0F94 _H	T01DR	8/16-bit composite timer 01 data register ch. 0	R/W	00000000 _B
0F95 _H	T00DR	8/16-bit composite timer 00 data register ch. 0	R/W	00000000 _B
0F96 _H	TMCR0	8/16-bit composite timer 00/01 timer mode control register ch. 0	R/W	00000000 _B
0F97 _H	T11CR0	8/16-bit composite timer 11 status control register 0 ch. 1	R/W	00000000 _B
0F98 _H	T10CR0	8/16-bit composite timer 10 status control register 0 ch. 1	R/W	00000000 _B
0F99 _H	T11DR	8/16-bit composite timer 11 data register ch. 1	R/W	00000000 _B
0F9A _H	T10DR	8/16-bit composite timer 10 data register ch. 1	R/W	00000000 _B
0F9B _H	TMCR1	8/16-bit composite timer 10/11 timer mode control register ch. 1	R/W	00000000 _B
0F9C _H	PPS01	8/16-bit PPG01 cycle setting buffer register ch. 0	R/W	11111111 _B
0F9D _H	PPS00	8/16-bit PPG00 cycle setting buffer register ch. 0	R/W	11111111 _B
0F9E _H	PDS01	8/16-bit PPG01 duty setting buffer register ch. 0	R/W	11111111 _B
0F9F _H	PDS00	8/16-bit PPG00 duty setting buffer register ch. 0	R/W	11111111 _B
0FA0 _H	PPS11	8/16-bit PPG11 cycle setting buffer register ch. 1	R/W	11111111 _B
0FA1 _H	PPS10	8/16-bit PPG10 cycle setting buffer register ch. 1	R/W	11111111 _B
0FA2 _H	PDS11	8/16-bit PPG11 duty setting buffer register ch. 1	R/W	11111111 _B
0FA3 _H	PDS10	8/16-bit PPG10 duty setting buffer register ch. 1	R/W	11111111 _B
0FA4 _H	PPGS	8/16-bit PPG start register	R/W	00000000 _B
0FA5 _H	REVC	8/16-bit PPG output inversion register	R/W	00000000 _B
0FA6 _H	TMRH0	16-bit reload timer timer register upper	R/W	00000000 _B
	TMRLRH0	16-bit reload timer reload register upper	R/W	00000000 _B
0FA7 _H	TMRL0	16-bit reload timer timer register lower	R/W	00000000 _B
	TMRLRL0	16-bit reload timer reload register lower	R/W	00000000 _B
0FA8 _H to 0FBD _H	—	(Disabled)	—	—
0FBE _H	PSSR0	UART/SIO dedicated baud rate generator prescaler selecting register ch. 0	R/W	00000000 _B
0FBF _H	BRSR0	UART/SIO dedicated baud rate generator baud rate setting register ch. 0	R/W	00000000 _B
0FC0 _H	PSSR1	UART/SIO dedicated baud rate generator prescaler selecting register ch. 1	R/W	00000000 _B
0FC1 _H	BRSR1	UART/SIO dedicated baud rate generator baud rate setting register ch. 1	R/W	00000000 _B
0FC2 _H	—	(Disabled)	—	—
0FC3 _H	AIDRL	A/D input disable register (lower)	R/W	00000000 _B
0FC4 _H	LCDC	LCDC control register	R/W	00010000 _B

(Continued)

(Continued)

Address	Register abbreviation	Register name	R/W	Initial value
0FC5 _H	LCDCE1	LCDC enable register 1	R/W	00110000 _B
0FC6 _H	LCDCE2	LCDC enable register 2	R/W	00000000 _B
0FC7 _H	LCDCE3	LCDC enable register 3	R/W	00000000 _B
0FC8 _H	LCDCE4	LCDC enable register 4	R/W	00000000 _B
0FC9 _H	LCDCE5	LCDC enable register 5	R/W	00000000 _B
0FCA _H	—	(Disabled)	—	—
0FCB _H	LCDCB1	LCDC blinking setting register 1	R/W	00000000 _B
0FCC _H	LCDCB2	LCDC blinking setting register 2	R/W	00000000 _B
0FCD _H to 0FDC _H	LCDRAM	LCDC display RAM	R/W	00000000 _B
0FDD _H to 0FE1 _H	—	(Disabled)	—	—
0FE2 _H	EVCR	Event counter control register	R/W	00000000 _B
0FE3 _H	WCDR	Watch counter data register	R/W	00111111 _B
0FE4 _H	CRTH	Main CR clock trimming register (upper)	R/W	0XXXXXXXX _B
0FE5 _H	CRTL	Main CR clock trimming register (lower)	R/W	00XXXXXXXX _B
0FE6 _H to 0FE8 _H	—	(Disabled)	—	—
0FE9 _H	CMCR	Clock monitoring control register	R/W	XX000000 _B
0FEA _H	CMDR	Clock monitoring data register	R	00000000 _B
0FEB _H	WDTH	Watchdog timer selection ID register (upper)	R	XXXXXXXX _B
0FEC _H	WDTL	Watchdog timer selection ID register (lower)	R	XXXXXXXX _B
0FED _H	—	(Disabled)	—	—
0FEE _H	ILSR	Input level select register	R/W	00000000 _B
0FEF _H	WICR	Interrupt pin control register	R/W	01000000 _B
0FF0 _H to 0FFF _H	—	(Disabled)	—	—

■ R/W access symbols

R/W : Readable / Writable

R : Read only

■ Initial value symbols

0 : The initial value of this bit is "0".

1 : The initial value of this bit is "1".

X : The initial value of this bit is indeterminate.

Note: Do not write to an address that is "(Disabled)". If a "(Disabled)" address is read, an indeterminate value is returned.

17. Interrupt Source Table

Interrupt source	Interrupt request number	Vector table address		Bit name of interrupt level setting register	Priority order of interrupt sources of the same level (occurring simultaneously)
		Upper	Lower		
External interrupt ch. 0	IRQ00	FFFA _H	FFFB _H	L00 [1:0]	<div style="text-align: center;"> High  Low </div>
External interrupt ch. 4					
External interrupt ch. 1	IRQ01	FFF8 _H	FFF9 _H	L01 [1:0]	
External interrupt ch. 5					
External interrupt ch. 2	IRQ02	FFF6 _H	FFF7 _H	L02 [1:0]	
External interrupt ch. 6					
External interrupt ch. 3	IRQ03	FFF4 _H	FFF5 _H	L03 [1:0]	
External interrupt ch. 7					
UART/SIO ch. 0	IRQ04	FFF2 _H	FFF3 _H	L04 [1:0]	
Low-voltage detection reset circuit					
8/16-bit composite timer ch. 0 (lower)	IRQ05	FFF0 _H	FFF1 _H	L05 [1:0]	
8/16-bit composite timer ch. 0 (upper)	IRQ06	FFEE _H	FFEF _H	L06 [1:0]	
—	IRQ07	FFEC _H	FFED _H	L07 [1:0]	
—	IRQ08	FFEA _H	FFEB _H	L08 [1:0]	
8/16-bit PPG ch. 1 (lower)	IRQ09	FFE8 _H	FFE9 _H	L09 [1:0]	
UART/SIO ch. 1					
8/16-bit PPG ch. 1 (upper)	IRQ10	FFE6 _H	FFE7 _H	L10 [1:0]	
16-bit reload timer ch. 0	IRQ11	FFE4 _H	FFE5 _H	L11 [1:0]	
8/16-bit PPG ch. 0 (upper)	IRQ12	FFE2 _H	FFE3 _H	L12 [1:0]	
8/16-bit PPG ch. 0 (lower)	IRQ13	FFE0 _H	FFE1 _H	L13 [1:0]	
8/16-bit composite timer ch. 1 (upper)	IRQ14	FFDE _H	FFDF _H	L14 [1:0]	
—	IRQ15	FFDC _H	FFDD _H	L15 [1:0]	
I ² C	IRQ16	FFDA _H	FFDB _H	L16 [1:0]	
—	IRQ17	FFD8 _H	FFD9 _H	L17 [1:0]	
8/10-bit A/D converter	IRQ18	FFD6 _H	FFD7 _H	L18 [1:0]	
Time-base timer	IRQ19	FFD4 _H	FFD5 _H	L19 [1:0]	
Watch prescaler	IRQ20	FFD2 _H	FFD3 _H	L20 [1:0]	
Watch counter					
—	IRQ21	FFD0 _H	FFD1 _H	L21 [1:0]	
8/16-bit composite timer ch. 1 (lower)	IRQ22	FFCE _H	FFCF _H	L22 [1:0]	
Flash memory	IRQ23	FFCC _H	FFCD _H	L23 [1:0]	

18. Electrical Characteristics

18.1 Absolute Maximum Ratings

Parameter	Symbol	Rating		Unit	Remarks
		Min	Max		
Power supply voltage*1	V_{CC}, AV_{CC}	$V_{SS} - 0.3$	$V_{SS} + 4.0$	V	*2
Power supply voltage for LCD	V0 to V3	$V_{SS} - 0.3$	$V_{SS} + 4.0$	V	Products with LCD internal division resistance*3
Input voltage*1	V_I	$V_{SS} - 0.3$	$V_{SS} + 6.0$	V	P23,P24*4
		$V_{SS} - 0.3$	$V_{SS} + 4.0$	V	Other than P23,P24*4
Output voltage*1	V_O	$V_{SS} - 0.3$	$V_{SS} + 4.0$	V	*4
Maximum clamp current	I_{CLAMP}	-2.0	+2.0	mA	Applicable to specific pins*5
Total maximum clamp current	$\Sigma I_{CLAMP} $	—	20	mA	Applicable to specific pins*5
"L" level maximum output current	I_{OL}	—	15	mA	Applicable to specific pins*5
"L" level average current	I_{OLAV}	—	4	mA	Applicable to specific pins*5 Average output current = operating current × operating ratio (1 pin)
"L" level total maximum output current	ΣI_{OL}	—	100	mA	
"L" level total average output current	ΣI_{OLAV}	—	50	mA	Total average output current = operating current × operating ratio (Total number of pins)
"H" level maximum output current	I_{OH}	—	-15	mA	Applicable to specific pins*5
"H" level average current	I_{OHAV}	—	-4	mA	Applicable to specific pins*5 Average output current = operating current × operating ratio (1 pin)
"H" level total maximum output current	ΣI_{OH}	—	-100	mA	
"H" level total average output current	ΣI_{OHAV}	—	-50	mA	Total average output current = operating current × operating ratio (Total number of pins)
Power consumption	P_d	—	320	mW	
Operating temperature	T_A	-40	+85	°C	
Storage temperature	T_{stg}	-55	+150	°C	

*1: These parameters are based on the condition that V_{SS} is 0.0 V.

*2: Apply equal potential to V_{CC} and AV_{CC} .

*3: V0 to V3 should not exceed $V_{CC} + 0.3$ V.

*4: V_I and V_O must not exceed $V_{CC} + 0.3$ V. V_I must not exceed the rated voltage. However, if the maximum current to/from an input is limited by means of an external component, the I_{CLAMP} rating is used instead of the V_I rating.

(Continued)

(Continued)

*5: Applicable to the following pins: P00 to P07, P10, P11, P13 to P16, P20 to P22, P40 to P43, P50 to P53, P60 to P67, P90 to P95, PA0 to PA3, PB0 to PB7, PC0 to PC7, PE0 to PE7, PG0

- Use under recommended operating conditions.
- Use with DC voltage (current).
- The HV (High Voltage) signal is an input signal exceeding the V_{CC} voltage. Always connect a limiting resistor between the HV (High Voltage) signal and the microcontroller before applying the HV (High Voltage) signal.
- The value of the limiting resistance should be set so that when the HV (High Voltage) signal is applied the input current to the microcontroller pin does not exceed rated values, either instantaneously or for prolonged periods.
- When the microcontroller drive current is low, such as in low power consumption modes, the HV (High Voltage) input potential may pass through the protective diode to increase the potential of the V_{CC} pin, and thus affects other devices.
- If the HV (High Voltage) signal is input when the microcontroller power supply is off (not fixed at 0 V), since power is supplied from the pins, incomplete operations may be executed.
- If the HV (High Voltage) input is input after power-on, since power is supplied from the pins, the voltage of power supply may not be sufficient to enable a power-on reset.
- Do not leave the HV (High Voltage) input pin unconnected.
- Example of a recommended circuit

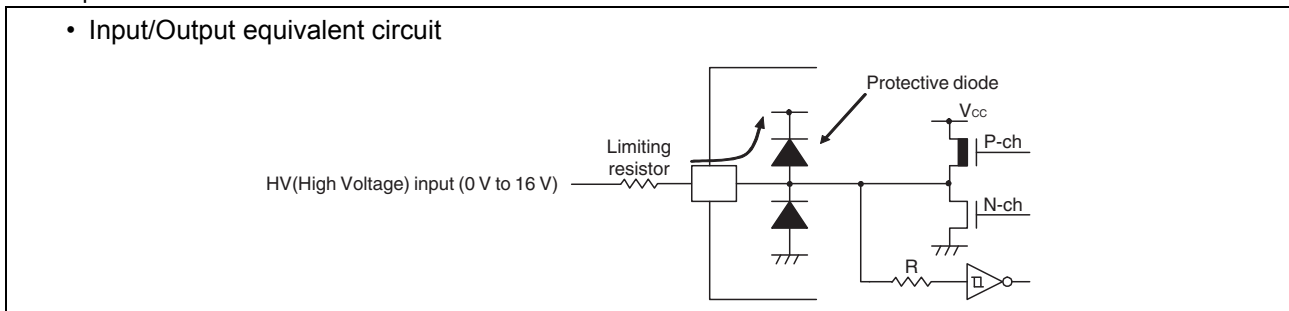

WARNING: Semiconductor devices can be permanently damaged by application of stress (voltage, current, temperature, etc.) in excess of absolute maximum ratings. Do not exceed these ratings.

18.2 Recommended Operating Conditions

 (V_{SS} = 0.0 V)

Parameter	Symbol	Value		Unit	Remarks	
		Min	Max			
Power supply voltage	V _{CC} , AV _{CC}	1.8*1*2*3	3.6	V	In normal operation, T _A = -10°C to +85°C	Other than on-chip debug mode
		2.0	3.6		In normal operation, T _A = -40°C to +85°C	
		1.5	3.6		Hold condition in stop mode	
		3.10*3	3.6		T _A = +5°C to +35°C	On-chip debug mode
		1.5	3.6		Hold condition in stop mode	
Operating temperature	T _A	-40	+85	°C	Other than on-chip debug mode	
		+5	+35		On-chip debug mode	

*1: The value varies depending on the operating frequency, the machine clock and the analog guaranteed range.

*2: The value is initially 2.03 V when the low-voltage detection reset is used.

*3: The threshold voltage can be set to be 2.03 V, 2.55 V, 3.10 V by software.

WARNING: The recommended operating conditions are required in order to ensure the normal operation of the semiconductor device. All of the device's electrical characteristics are warranted when the device is operated within these ranges.

Always use semiconductor devices within their recommended operating condition ranges.

Operation outside these ranges may adversely affect reliability and could result in device failure.

No warranty is made with respect to uses, operating conditions, or combinations not represented on the data sheet. Users considering application outside the listed conditions are advised to contact their representatives beforehand.

18.3 DC Characteristics
 $(V_{CC} = 3.0 V \pm 10\%, V_{SS} = 0.0 V, T_A = -40^\circ C \text{ to } +85^\circ C)$

Parameter	Symbol	Pin name	Condition	Value			Unit	Remarks
				Min	Typ ^{*5}	Max		
"H" level input voltage	V _{IHI1}	P10, P95 ^{*1} , PE6 ^{*2}	*3	0.7 V _{CC}	—	V _{CC} + 0.3	V	When selecting CMOS input level
	V _{IHI2}	P23, P24	*3	0.7 V _{CC}	—	V _{SS} + 5.5	V	
	V _{IHS1}	P00 to P07, P10 to P16, P20 to P22, P40 to P43 ^{*1} , P50 to P53 ^{*1} , P60 to P67, P90 to P92, P93 to P95 ^{*1} , PA0 to PA3, PB0 to PB7, PC0 to PC3, PC4 to PC7 ^{*1} , PE0 to PE7, PG0 ^{*1}	*3	0.8 V _{CC}	—	V _{CC} + 0.3	V	Hysteresis input
	V _{IHS2}	P23, P24	*3	0.8 V _{CC}	—	V _{SS} + 5.5	V	
	V _{IHM}	RST	—	0.8 V _{CC}	—	V _{CC} + 0.3	V	
"L" level input voltage	V _{IL}	P10, P23, P24, P95 ^{*1} , PE6 ^{*2}	*3	V _{SS} - 0.3	—	0.3 V _{CC}	V	When selecting CMOS input level
	V _{ILS}	P00 to P07, P10 to P16, P20 to P24, P40 to P43 ^{*1} , P50 to P53 ^{*1} , P60 to P67, P90 to P92, P93 to P95 ^{*1} , PA0 to PA3, PB0 to PB7, PC0 to PC3, PC4 to PC7 ^{*1} , PE0 to PE7, PG0 ^{*1}	*3	V _{SS} - 0.3	—	0.2 V _{CC}	V	Hysteresis input
	V _{ILM}	RST	—	V _{SS} - 0.3	—	0.2 V _{CC}	V	
"H" level output voltage	V _{OH}	Output pin other than P12, P23, P24	I _{OH} = 4.0 mA	V _{CC} - 0.5	—	—	V	
"L" level output voltage	V _{OL}	Output pin other than RST	I _{OL} = 4.0 mA	—	—	0.4	V	

(Continued)

$(V_{CC} = 3.0 V \pm 10\%, V_{SS} = 0.0 V, T_A = -40^\circ C \text{ to } +85^\circ C)$

Parameter	Symbol	Pin name	Condition	Value			Unit	Remarks
				Min	Typ ^{*5}	Max		
Input leakage current (Hi-Z output leakage current)	I_{LI}	Ports other than P12, P23, P24	$0.0 V < V_I < V_{CC}$	-5	—	+5	μA	When pull-up resistance is disabled
Open-drain output leakage voltage	I_{LIOD}	P12, P23, P24	$0.0 V < V_I < V_{SS} + 5.5 V$	—	—	5	μA	
Pull-up resistance	R_{PULL}	P00 to P03, P10, P11, P13 to P16, P20 to P22, P50 to P53 ^{*1} , P94, P95 ^{*1} , PG0 ^{*1}	$V_I = 0.0 V$	25	50	100	$k\Omega$	When pull-up resistance is enabled
Input capacitance	C_{IN}	Other than V_{CC} and V_{SS}	$f = 1 \text{ MHz}$	—	5	15	pF	
Power supply current ^{*4}	I_{CC}	V_{CC} (External clock operation)	$F_{CH} = 32 \text{ MHz}$ $F_{MP} = 16 \text{ MHz}$ Main clock mode (divided by 2)	—	16.5	27.7	mA	Except during Flash memory programming and erasing
			$F_{CH} = 32 \text{ MHz}$ $F_{MP} = 16 \text{ MHz}$ Main sleep mode (divided by 2)	—	38.1	44.9	mA	During Flash memory programming and erasing
	I_{CCS}		$F_{CL} = 32 \text{ kHz}$ $F_{MPL} = 16 \text{ kHz}$ Subclock mode (divided by 2) $T_A = +25^\circ C$	—	9	15.9	mA	
	I_{CCL}			—	22.6	37.9	μA	

(Continued)

$(V_{CC} = 3.0 V \pm 10\%, V_{SS} = 0.0 V, T_A = -40^\circ C \text{ to } +85^\circ C)$

Parameter	Symbol	Pin name	Condition	Value			Unit	Remarks
				Min	Typ ^{*5}	Max		
Power supply current ^{*4}	I _{CCLS}	V _{CC} (External clock operation)	F _{CL} = 32 kHz F _{MPL} = 16 kHz Subsleep mode (divided by 2) T _A = +25°C	—	11.2	16.5	μA	
	I _{CCT}		F _{CL} = 32 kHz Watch mode Main stop mode T _A = +25°C	—	6.7	9	μA	
	I _{CCMPLL}		F _{CH} = 4 MHz F _{MPL} = 10 MHz Main PLL mode (multiplied by 2.5)	—	10.1	19.2	mA	
			F _{CH} = 6.4 MHz F _{MPL} = 16 MHz Main PLL mode (multiplied by 2.5)	—	16.2	30.7	mA	
	I _{CCMCR}		F _{CRH} = 12.5 MHz F _{MPL} = 12.5 MHz Main CR clock mode	—	7.9	13.2	mA	
	I _{CCSCR}		Sub-CR clock mode (divided by 2) T _A = +25°C	—	77.8	138.5	μA	
	I _{CTS}		F _{CH} = 32 MHz Time-base timer mode T _A = +25°C	—	4.3	7.4	mA	
	I _{CCH}		Substop mode T _A = +25°C	—	1	5	μA	
	I _A		AV _{CC}	Current consumption for A/D conversion at 16 MHz	—	0.8	1.9	mA
	I _{AH}	Current consumption for stopping A/D conversion at 16 MHz		—	1	5	μA	

(Continued)

(Continued)

 $(V_{CC} = 3.0 V \pm 10\%, V_{SS} = 0.0 V, T_A = -40^\circ C \text{ to } +85^\circ C)$

Parameter	Symbol	Pin name	Condition	Value			Unit	Remarks
				Min	Typ ^{*5}	Max		
Power supply current ^{*4}	I_{LVD}	V_{CC}	Current consumption for the low-voltage detection reset circuit	—	6	9.8	μA	
	I_{CRH}		Current consumption for the main CR oscillator	—	0.5	0.6	mA	
	I_{CRL}		Current consumption for the sub-CR oscillator oscillating at 100 kHz	—	20	72	μA	
LCD internal division resistance	R_{LCD}	—	Between V3 and V_{SS}	—	300	—	k Ω	
COM0 to COM3 output impedance	R_{VCOM}	COM0 to COM3	V1 to V3 = 3.6 V	—	—	5	k Ω	
SEG00 to SEG39 output impedance	R_{VSEG}	SEG00 to SEG39		—	—	7	k Ω	
LCD leakage current	I_{LCDL}	V0 to V3, COM0 to COM3, SEG00 to SEG39	—	-1	—	+1	μA	

*1: It is for MB95310L Series.

*2: It is for MB95370L Series.

*3: The input level can be switched between “CMOS input level” and “hysteresis input level”. The input level selection register (ILSR) is used to switch between the two input levels.

*4: • The power supply current is determined by the external clock. When the low-voltage detection option is selected, the power-supply current will be the sum of adding the current consumption of the low-voltage detection circuit (I_{LVD}) to one of the value from I_{CC} to I_{CCH} . In addition, when both the low-voltage detection option and the CR oscillator are selected, the power supply current will be the sum of adding up the current consumption of the low-voltage detection circuit, the current consumption of the CR oscillators (I_{CRH} , I_{CRL}) and a specified value. In on-chip debug mode, the CR oscillator (I_{CRH}) and the low-voltage detection circuit are always enabled, and current consumption therefore increases accordingly.

• See “18.4 AC Characteristics: Clock Timing” for F_{CH} and F_{CL} .

• See “18.4 AC Characteristics: 18.4.2 Source Clock/Machine Clock” for F_{MP} and F_{MPL} .

*5: $V_{CC} = 3.0 V$, $T_A = +25^\circ C$

18.4 AC Characteristics

18.4.1 Clock Timing

($V_{CC} = 3.0 V \pm 10\%$, $V_{SS} = 0.0 V$, $T_A = -40^\circ C$ to $+85^\circ C$)

Parameter	Symbol	Pin name	Condition	Value			Unit	Remarks		
				Min	Typ	Max				
Clock frequency	F_{CH}	X0, X1	—	1.00	—	16.25	MHz	When the main oscillation circuit is used		
				1.00	—	32.50	MHz	When the main external clock is used		
				3.00	—	8.13	MHz	Main PLL multiplied by 2		
				3.00	—	6.5	MHz	Main PLL multiplied by 2.5		
				3.00	—	4.06	MHz	Main PLL multiplied by 4		
	F_{CRH}	—	—	—	12.25	12.5	12.75	MHz	Operating conditions: • The main CR clock is used. • $T_A = -10^\circ C$ to $+85^\circ C$	
					9.8	10	10.2	MHz		
					7.84	8	8.16	MHz		
					0.98	1	1.02	MHz		
		—	—	—	—	12.1875	12.5	12.8125	MHz	Operating conditions: • The main CR clock is used. • $T_A = -40^\circ C$ to $-10^\circ C$
						9.75	10	10.25	MHz	
						7.8	8	8.2	MHz	
						0.975	1	1.025	MHz	
	F_{CL}	X0A, X1A	—	—	—	32.768	—	kHz	When the sub-oscillation circuit is used	
—					32.768	—	kHz	When the sub-external clock is used		
50					100	200	kHz	When the sub-CR clock is used		
F_{CRL}	—	—	—	50	100	200	kHz	When the sub-CR clock is used		
				50	100	200	kHz	When the sub-CR clock is used		
Clock cycle time	t_{HCYL}	X0, X1	—	61.5	—	1000	ns	When the main oscillation circuit is used		
				30.8	—	1000	ns	When the external clock is used		
	t_{LCYL}	X0A, X1A	—	—	30.5	—	μs	When the subclock is used		
Input clock pulse width	t_{WH1} t_{WL1}	X0	—	61.5	—	—	ns	When using external clock and the duty ratio is about 30% to 70%		
	t_{WH2} t_{WL2}	X0A		—	15.2	—	μs			
Input clock rise time and fall time	t_{CR} t_{CF}	X0, X0A	X1: open	—	—	5	ns	When the external clock is used		
CR oscillation start time	t_{CRHWK}	—	—	—	—	150	μs	When the main CR clock is used		
	t_{CRLWK}	—	—	—	—	10	μs	When the sub-CR clock is used		

- Input waveform generated when an external clock (main clock) is used

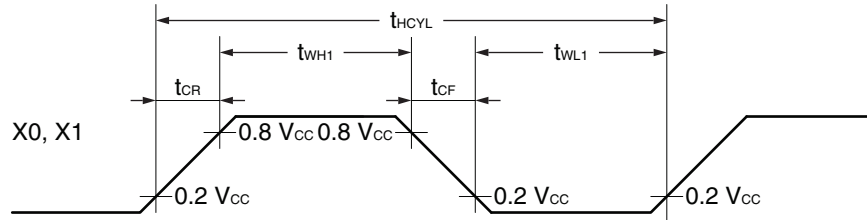

- Figure of main clock input port external connection

When a crystal oscillator or a ceramic oscillator is used When the external clock is used (X1 is open) When the external clock is used

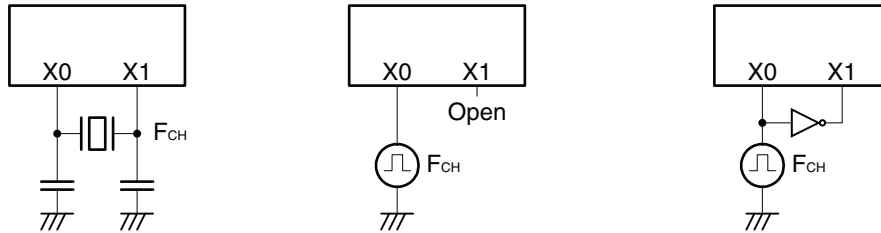

- Input waveform generated when an external clock (subclock) is used

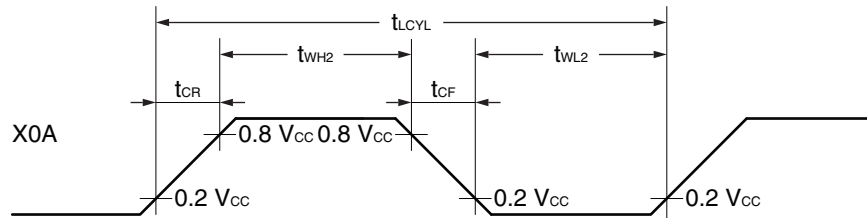

- Figure of subclock input port external connection

When a crystal oscillator or a ceramic oscillator is used When the external clock is used



18.4.2 Source Clock/Machine Clock
 $(V_{CC} = 3.0 V \pm 10\%, V_{SS} = 0.0 V, T_A = -40^\circ C \text{ to } +85^\circ C)$

Parameter	Symbol	Pin name	Value			Unit	Remarks
			Min	Typ	Max		
Source clock cycle time*1	t_{SCLK}	—	61.5	—	2000	ns	When the main oscillation clock is used Min: $F_{CH} = 8.125 \text{ MHz}$, multiplied by the PLL multiplier of 2 Max: $F_{CH} = 1 \text{ MHz}$, divided by 2
			80	—	1000	ns	When the main CR clock is used Min: $F_{CRH} = 12.5 \text{ MHz}$ Max: $F_{CRH} = 1 \text{ MHz}$
			—	61	—	μs	When the sub-oscillation clock is used $F_{CL} = 32.768 \text{ kHz}$, divided by 2
			—	20	—	μs	When the sub-CR clock is used $F_{CRL} = 100 \text{ kHz}$, divided by 2
Source clock frequency	F_{SP}	—	0.50	—	16.25	MHz	When the main oscillation clock is used
			1	—	12.5	MHz	When the main CR clock is used
	—		16.384	—	kHz	When the sub-oscillation clock is used	
	F_{SPL}		—	50	—	kHz	When the sub-CR clock is used $F_{CRL} = 100 \text{ kHz}$, divided by 2
Machine clock cycle time*2 (minimum instruction execution time)	t_{MCLK}	—	61.5	—	32000	ns	When the main oscillation clock is used Min: $F_{SP} = 16.25 \text{ MHz}$, no division Max: $F_{SP} = 0.5 \text{ MHz}$, divided by 16
			80	—	16000	ns	When the main CR clock is used Min: $F_{SP} = 12.5 \text{ MHz}$ Max: $F_{SP} = 1 \text{ MHz}$, divided by 16
			61	—	976.5	μs	When the sub-oscillation clock is used Min: $F_{SPL} = 16.393 \text{ kHz}$, no division Max: $F_{SPL} = 16.393 \text{ kHz}$, divided by 16
			20	—	320	μs	When the sub-CR clock is used Min: $F_{SPL} = 50 \text{ kHz}$, no division Max: $F_{SPL} = 50 \text{ kHz}$, divided by 16
Machine clock frequency	F_{MP}	—	0.031	—	16.25	MHz	When the main oscillation clock is used
			0.0625	—	12.5	MHz	When the main CR clock is used
	F_{MPL}		1.024	—	16.384	kHz	When the sub-oscillation clock is used
			3.125	—	50	kHz	When the sub-CR clock is used $F_{CRL} = 100 \text{ kHz}$

*1: This is the clock before it is divided according to the division ratio set by the machine clock divide ratio select bits (SYCC:DIV1 and DIV0). This source clock is divided to become a machine clock according to the division ratio set by the machine clock divide ratio select bits (SYCC:DIV1 and DIV0). In addition, a source clock can be selected from the following.

- Main clock divided by 2
- PLL multiplication of main clock (select from 2, 2.5, 4 multiplication)
- Main CR clock divided by 2
- Subclock divided by 2
- Sub-CR clock divided by 2

(Continued)

(Continued)

*2: This is the operating clock of the microcontroller. A machine clock can be selected from the following.

- Source clock (no division)
- Source clock divided by 4
- Source clock divided by 8
- Source clock divided by 16

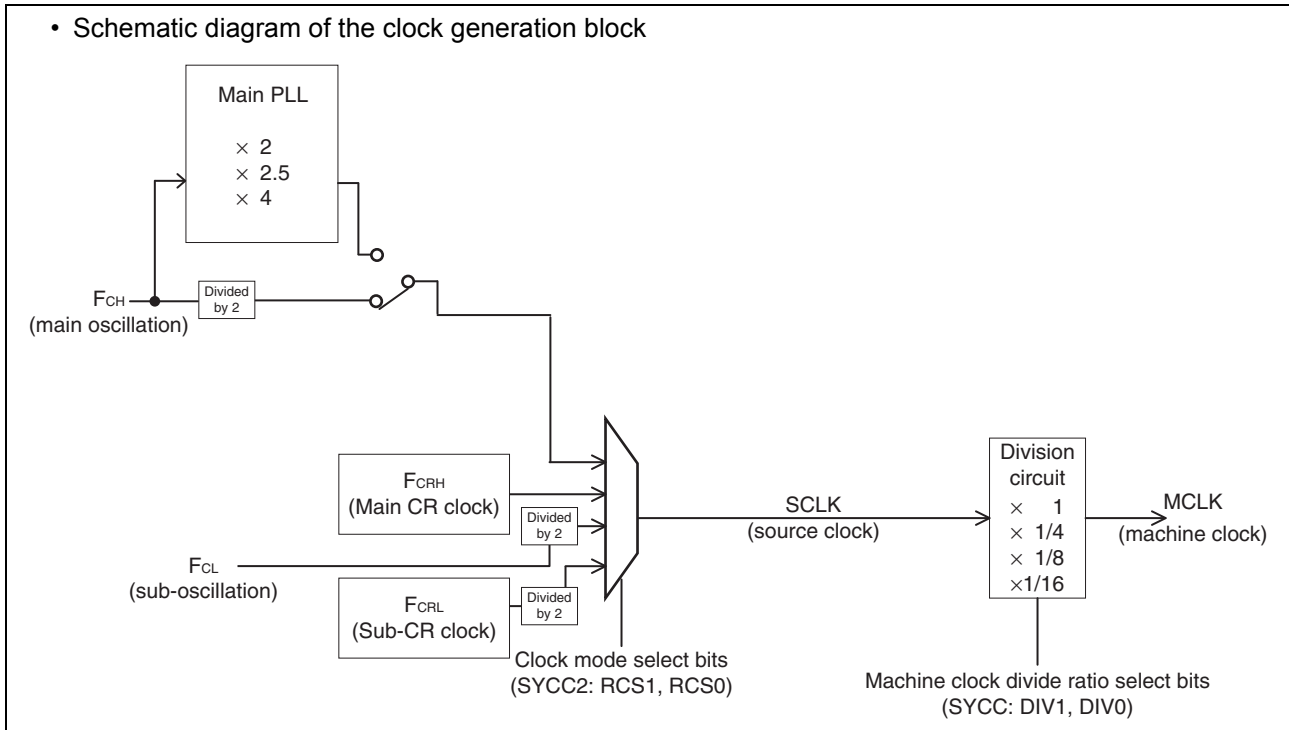

- Operating voltage - Operating frequency (When $T_A = -10^\circ\text{C}$ to $+85^\circ\text{C}$)
Without the on-chip debug function

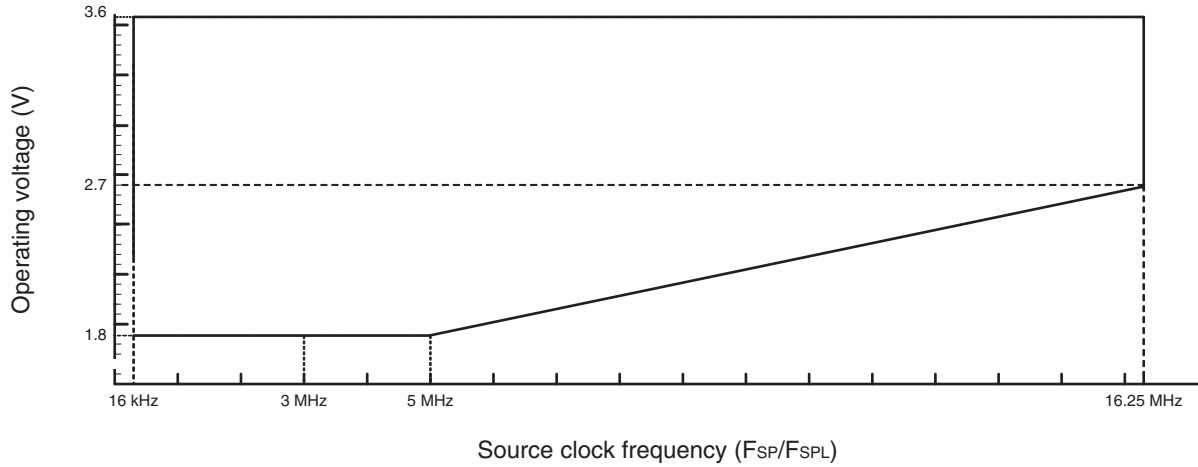

- Operating voltage - Operating frequency (When $T_A = -40^\circ\text{C}$ to $+85^\circ\text{C}$)
Without the on-chip debug function

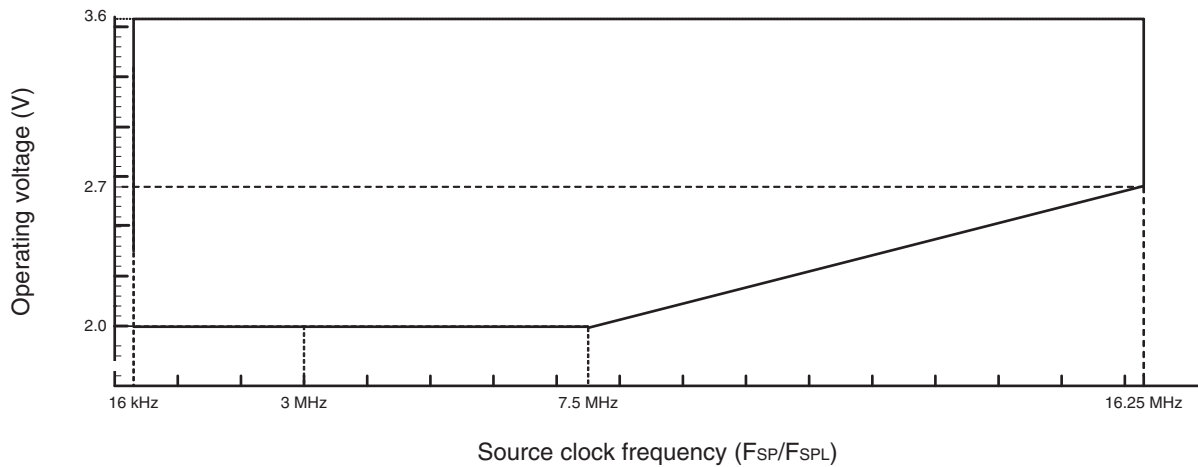

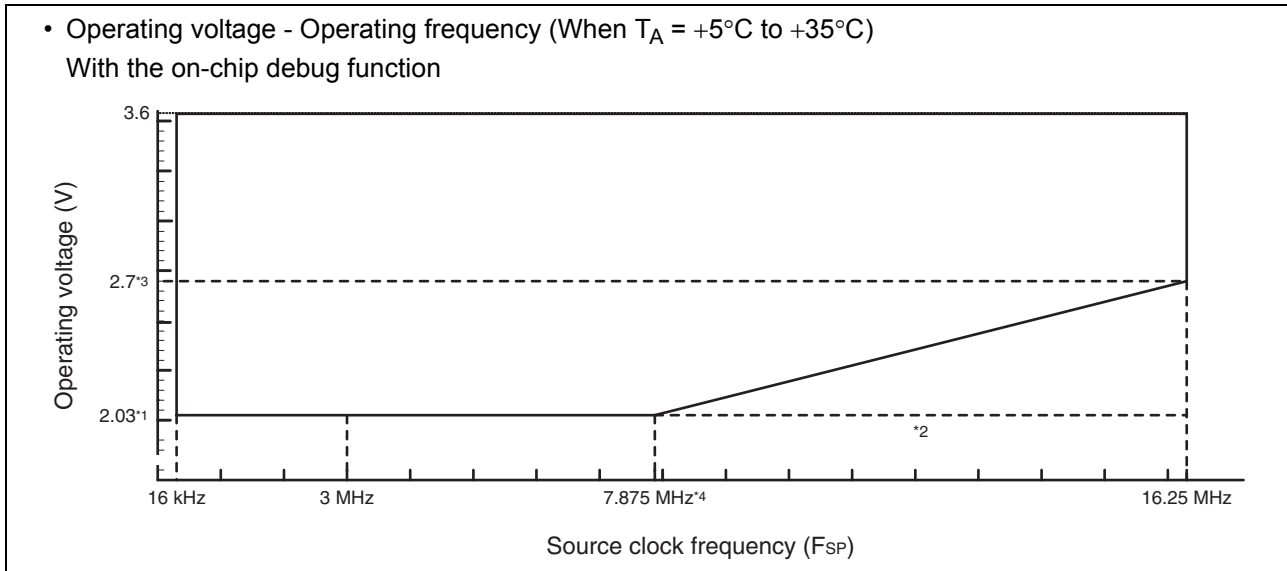

*1: This is the default LVD reset clear threshold: $1.93\text{ V} \pm 0.10\text{ V}$. It can also be set to $2.40\text{ V} \pm 0.15\text{ V}$ or $2.95\text{ V} \pm 0.15\text{ V}$.

*2: If the LVD reset clear threshold is set to $2.95\text{ V} \pm 0.15\text{ V}$, the slope from 10 MHz to 16.25 MHz should be a horizontal line.

*3: The operating voltage becomes 3.1 V if the LVD reset clear threshold is set to $2.95\text{ V} \pm 0.15\text{ V}$.

*4: The source clock frequency becomes 14.375 MHz if the LVD reset clear threshold is set to $2.40\text{ V} \pm 0.15\text{ V}$.

18.4.3 External Reset

($V_{CC} = 3.0\text{ V} \pm 10\%$, $V_{SS} = 0.0\text{ V}$, $T_A = -40^\circ\text{C}$ to $+85^\circ\text{C}$)

Parameter	Symbol	Value		Unit	Remarks
		Min	Max		
RST "L" level pulse width	t_{RSTL}	$2 t_{MCLK}^{*1}$	—	ns	In normal operation
		Oscillation time of the oscillator ^{*2} + 100	—	μs	In stop mode, subclock mode, subsleep mode, watch mode, and power-on
		100	—	μs	In time-base timer mode

*1: See "(2) Source Clock/Machine Clock" for t_{MCLK} .

*2: The oscillation time of an oscillator is the time for it to reach 90% of its amplitude. The crystal oscillator has an oscillation time of between several ms and tens of ms. The ceramic oscillator has an oscillation time of between hundreds of μs and several ms. The external clock has an oscillation time of 0 ms. The CR oscillator clock has an oscillation time of between several μs and several ms.

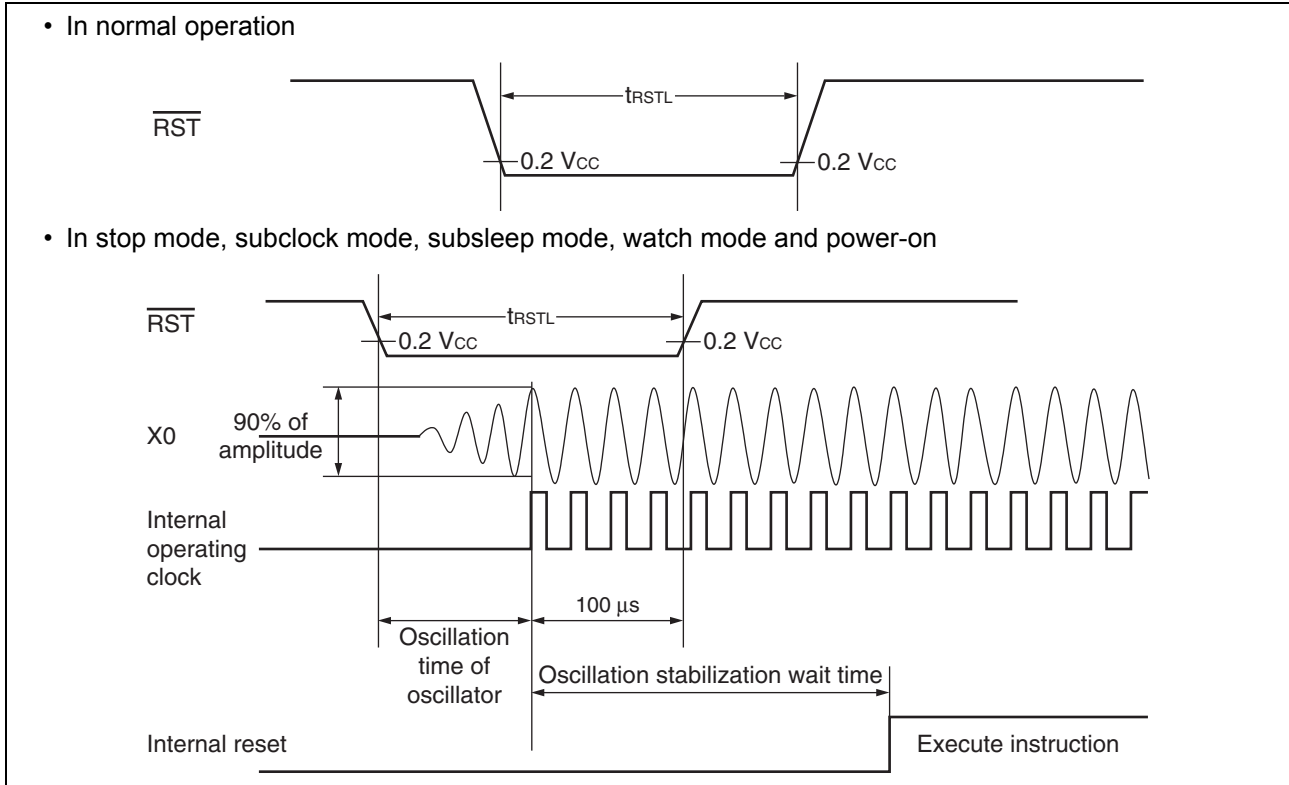

18.4.4 Power-on Reset

($V_{SS} = 0.0\text{ V}$, $T_A = -40^\circ\text{C}$ to $+85^\circ\text{C}$)

Parameter	Symbol	Condition	Value		Unit	Remarks
			Min	Max		
Power supply rising time	t_R	—	—	50	ms	
Power supply cutoff time	t_{OFF}	—	1	—	ms	Wait time until power-on

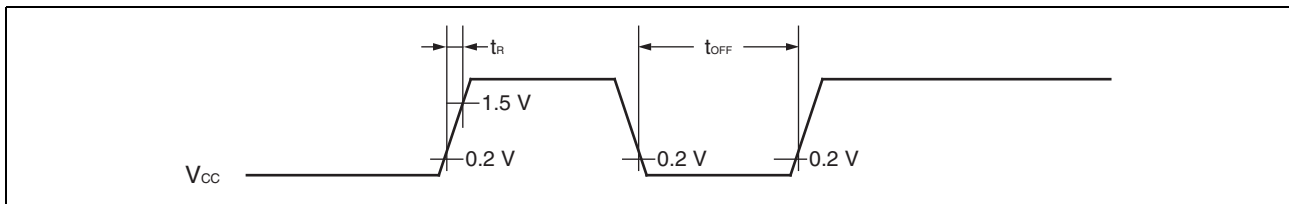

Note: A sudden change of power supply voltage may activate the power-on reset function. When changing the power supply voltage during the operation, set the slope of rising to a value below within 20 mV/ms as shown below.

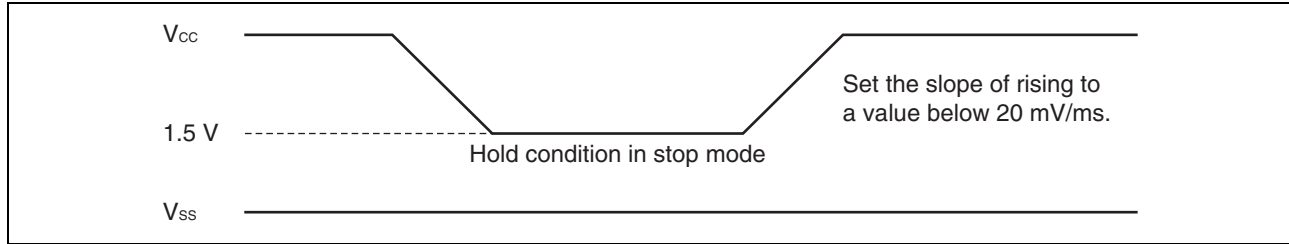

18.4.5 Peripheral Input Timing

($V_{CC} = 3.0 V \pm 10\%$, $V_{SS} = 0.0 V$, $T_A = -40^\circ C$ to $+85^\circ C$)

Parameter	Symbol	Pin name	Value		Unit
			Min	Max	
Peripheral input "H" pulse width	t_{LH}	INT00 to INT07, EC0, EC1, ADTG	$2 t_{MCLK}^*$	—	ns
Peripheral input "L" pulse width	t_{HL}		$2 t_{MCLK}^*$	—	ns

*: See "(2) Source Clock/Machine Clock" for t_{MCLK} .

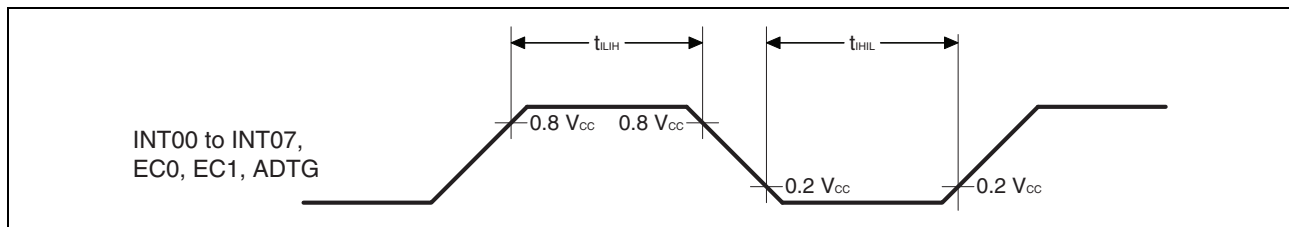

18.4.6 UART/SIO, Serial I/O Timing

($V_{CC} = 3.0 V \pm 10\%$, $AV_{SS} = V_{SS} = 0.0 V$, $T_A = -40^\circ C$ to $+85^\circ C$)

Parameter	Symbol	Pin name	Condition	Value		Unit
				Min	Max	
Serial clock cycle time	t_{SCYC}	UCK0, UCK1	Internal clock operation output pin: $C_L = 80 pF + 1 TTL$	$4 t_{MCLK}^*$	—	ns
UCK $\downarrow \rightarrow$ UO time	t_{SLOVI}	UCK0, UCK1, UO0, UO1		-190	+190	ns
Valid UI \rightarrow UCK \uparrow	t_{IVSHI}	UCK0, UCK1, UI0, UI1		$2 t_{MCLK}^*$	—	ns
UCK $\uparrow \rightarrow$ valid UI hold time	t_{SHIXI}	UCK0, UCK1, UI0, UI1		$2 t_{MCLK}^*$	—	ns
Serial clock "H" pulse width	t_{SHSL}	UCK0, UCK1	External clock operation output pin: $C_L = 80 pF + 1 TTL$	$4 t_{MCLK}^*$	—	ns
Serial clock "L" pulse width	t_{SLSH}	UCK0, UCK1		$4 t_{MCLK}^*$	—	ns
UCK $\downarrow \rightarrow$ UO time	t_{SLOVE}	UCK0, UCK1, UO0, UO1		—	190	ns
Valid UI \rightarrow UCK \uparrow	t_{IVSHE}	UCK0, UCK1, UI0, UI1		$2 t_{MCLK}^*$	—	ns
UCK $\uparrow \rightarrow$ valid UI hold time	t_{SHIXE}	UCK0, UCK1, UI0, UI1		$2 t_{MCLK}^*$	—	ns

*: See "(2) Source Clock/Machine Clock" for t_{MCLK} .

• Internal shift clock mode

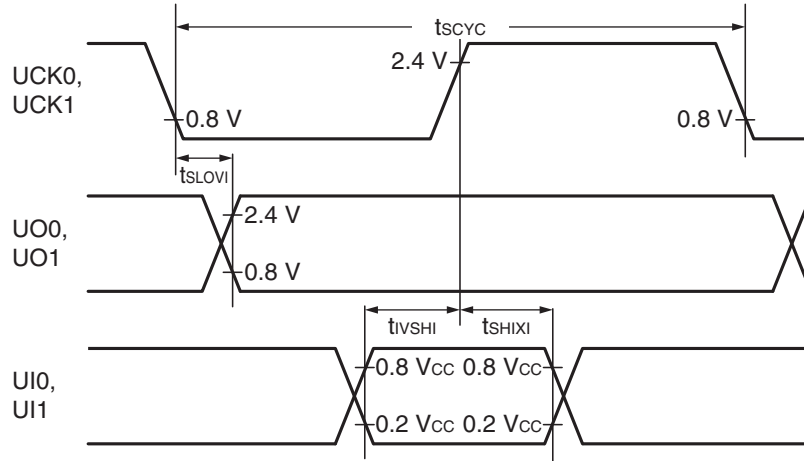

• External shift clock mode

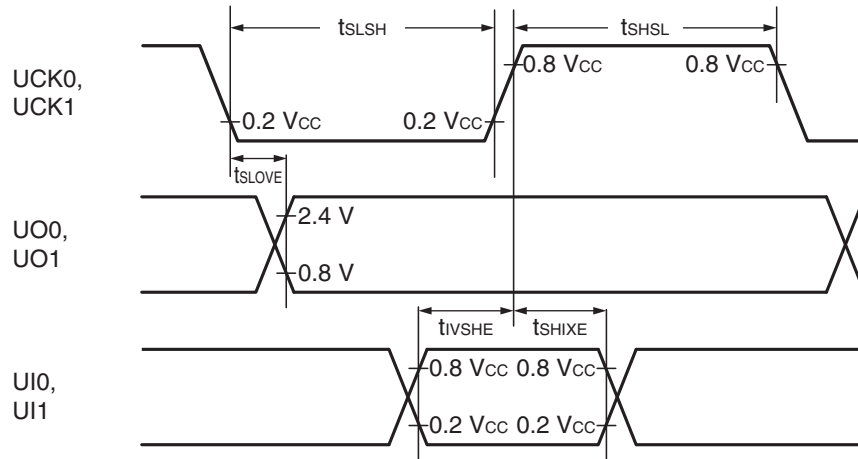

18.4.7 Low-voltage Detection
 $(V_{SS} = 0.0 \text{ V}, V_{CC} = 1.8 \text{ V to } 3.6 \text{ V}, T_A = -40^\circ\text{C to } +85^\circ\text{C})$

Parameter	Symbol	Value			Unit	Remarks
		Min	Typ	Max		
Power release voltage 0	V_{PDL0+}	1.83	1.93	2.03	V	At power supply rise
Power detection voltage 0	V_{PDL0-}	1.80	1.90	2.00	V	At power supply fall
Power release voltage 1	V_{PDL1+}	2.25	2.40	2.55	V	At power supply rise
Power detection voltage 1	V_{PDL1-}	2.20	2.35	2.50	V	At power supply fall
Power release voltage 2	V_{PDL2+}	2.80	2.95	3.10	V	At power supply rise
Power detection voltage 2	V_{PDL2-}	2.70	2.85	3.00	V	At power supply fall
Interrupt release voltage 0	V_{IDL0+}	2.03	2.18	2.33	V	At power supply rise
Interrupt detection voltage 0	V_{IDL0-}	2.00	2.15	2.30	V	At power supply fall
Interrupt release voltage 1	V_{IDL1+}	2.25	2.40	2.55	V	At power supply rise
Interrupt detection voltage 1	V_{IDL1-}	2.20	2.35	2.50	V	At power supply fall
Interrupt release voltage 2	V_{IDL2+}	2.46	2.61	2.76	V	At power supply rise
Interrupt detection voltage 2	V_{IDL2-}	2.40	2.55	2.70	V	At power supply fall
Interrupt release voltage 3	V_{IDL3+}	2.67	2.82	2.97	V	At power supply rise
Interrupt detection voltage 3	V_{IDL3-}	2.60	2.75	2.90	V	At power supply fall
Interrupt release voltage 4	V_{IDL4+}	2.90	3.10	3.30	V	At power supply rise
Interrupt detection voltage 4	V_{IDL4-}	2.80	3.00	3.20	V	At power supply fall
Power supply start voltage	V_{off}	—	—	1.8	V	
Power supply end voltage	V_{on}	3.3	—	—	V	
Power supply voltage change time (at power supply rise)	t_r	3000	—	—	μs	Slope of power supply that the reset release signal generates within the rating (V_{PDL+}/V_{IDL+})
Power supply voltage change time (at power supply fall)	t_f	3000	—	—	μs	Slope of power supply that the reset detection signal generates within the rating (V_{PDL-}/V_{IDL-})

(Continued)

(Continued)

($V_{SS} = 0.0\text{ V}$, $V_{CC} = 1.8\text{ V to }3.6\text{ V}$, $T_A = -40^\circ\text{C to }+85^\circ\text{C}$)

Parameter	Symbol	Value			Unit	Remarks
		Min	Typ	Max		
Power reset release delay time	t_{dp1}	10	—	300	μs	
Power reset detection delay time	t_{dp2}	—	—	150	μs	
Interrupt reset release delay time	t_{di1}	10	—	200	μs	
Interrupt reset detection delay time	t_{di2}	—	—	150	μs	

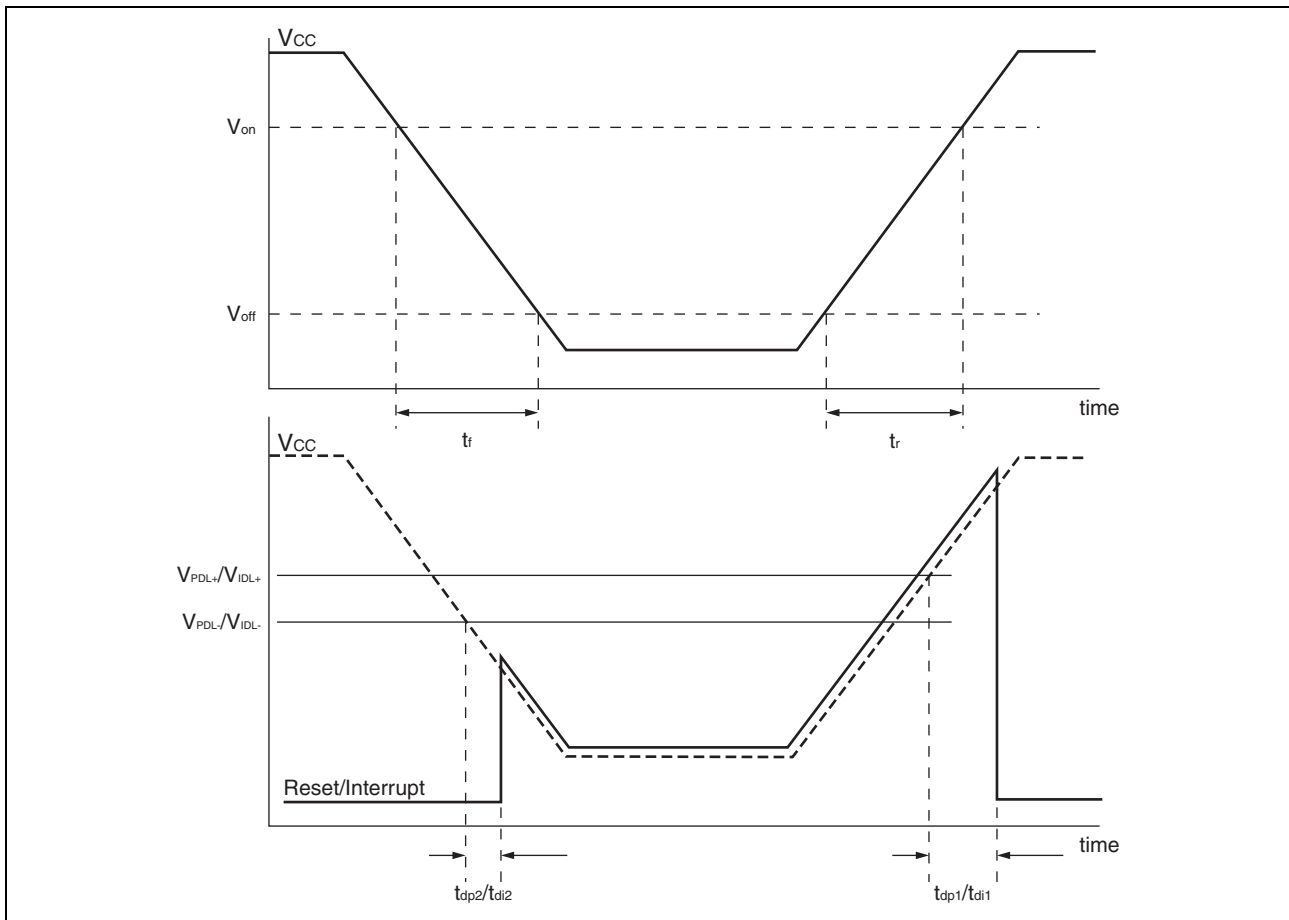

18.4.8 I²C Timing
 $(V_{CC} = 3.0\text{ V} \pm 10\%, AV_{SS} = V_{SS} = 0.0\text{ V}, T_A = -40^\circ\text{C to } +85^\circ\text{C})$

Parameter	Symbol	Pin name	Conditions	Value				Unit
				Standard-mode		Fast-mode		
				Min	Max	Min	Max	
SCL clock frequency	f_{SCL}	SCL0	R = 1.7 k Ω , C = 50 pF* ¹	0	100	0	400	kHz
(Repeat) Start condition hold time SDA \rightarrow \emptyset SCL \rightarrow	$t_{HD;STA}$	SCL0, SDA0		4.0	—	0.6	—	μs
SCL clock "L" width	t_{LOW}	SCL0		4.7	—	1.3	—	μs
SCL clock "H" width	t_{HIGH}	SCL0		4.0	—	0.6	—	μs
(Repeat) Start condition setup time SCL $f \emptyset$ SDA \rightarrow	$t_{SU;STA}$	SCL0, SDA0		4.7	—	0.6	—	μs
Data hold time SCL $\rightarrow \emptyset$ SDA $\rightarrow f$	$t_{HD;DAT}$	SCL0, SDA0		0	3.45* ²	0	0.9* ³	μs
Data setup time SDA $\rightarrow f \emptyset$ SCL f	$t_{SU;DAT}$	SCL0, SDA0		0.25	—	0.1	—	μs
Stop condition setup time SCL $f \emptyset$ SDA f	$t_{SU;STO}$	SCL0, SDA0		4.0	—	0.6	—	μs
Bus free time between stop condition and start condition	t_{BUF}	SCL0, SDA0		4.7	—	1.3	—	μs

*1: R represents the pull-up resistor of the SCL0 and SDA0 lines, and C the load capacitor of the SCL0 and SDA0 lines.

*2: The maximum $t_{HD;DAT}$ in the Standard-mode is applicable only when the time during which the device is holding the SCL signal at "L" (t_{LOW}) does not extend.

*3: A Fast-mode I²C-bus device can be used in a Standard-mode I²C-bus system, provided that the condition of $t_{SU;DAT} \geq 250\text{ ns}$ is fulfilled.

(Continued)

(Continued)

Note: The rating of the input data set-up time in the device connected to the bus cannot be satisfied depending on the load capacitance or pull-up resistor.

Be sure to adjust the pull-up resistor of SDA0 and SCL0 if the rating of the input data set-up time cannot be satisfied.

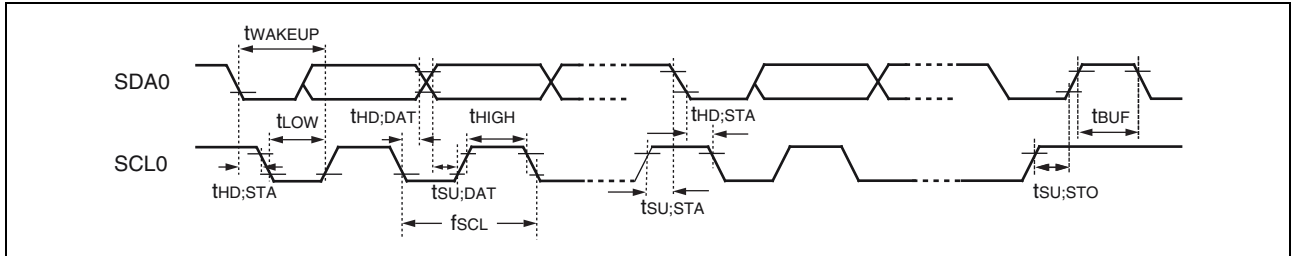

$(V_{CC} = 3.0 V \pm 10\%, AV_{SS} = V_{SS} = 0.0 V, T_A = -40^\circ C \text{ to } +85^\circ C)$

Parameter	Symbol	Pin name	Conditions	Value*2		Unit	Remarks
				Min	Max		
SCL clock "L" width	t_{LOW}	SCL0	R = 1.7 k Ω , C = 50 pF*1	$(2 + nm / 2) t_{MCLK} - 20$	—	ns	Master mode
SCL clock "H" width	t_{HIGH}	SCL0		$(nm / 2) t_{MCLK} - 20$	$(nm / 2) t_{MCLK} + 20$	ns	Master mode
Start condition hold time	$t_{HD;STA}$	SCL0, SDA0		$(-1 + nm / 2) t_{MCLK} - 20$	$(-1 + nm) t_{MCLK} + 20$	ns	Master mode Maximum value is applied when m, n = 1, 8. Otherwise, the minimum value is applied.
Stop condition setup time	$t_{SU;STO}$	SCL0, SDA0		$(1 + nm / 2) t_{MCLK} - 20$	$(1 + nm / 2) t_{MCLK} + 20$	ns	Master mode
Start condition setup time	$t_{SU;STA}$	SCL0, SDA0		$(1 + nm / 2) t_{MCLK} - 20$	$(1 + nm / 2) t_{MCLK} + 20$	ns	Master mode
Bus free time between stop condition and start condition	t_{BUF}	SCL0, SDA0		$(2 nm + 4) t_{MCLK} - 20$	—	ns	
Data hold time	$t_{HD;DAT}$	SCL0, SDA0		$3 t_{MCLK} - 20$	—	ns	Master mode
Data setup time	$t_{SU;DAT}$	SCL0, SDA0		$(-2 + nm / 2) t_{MCLK} - 20$	$(-1 + nm / 2) t_{MCLK} + 20$	ns	Master mode When assuming that "L" of SCL is not extended, the minimum value is applied to first bit of continuous data. Otherwise, the maximum value is applied.

(Continued)

$(V_{CC} = 3.0 V \pm 10\%, AV_{SS} = V_{SS} = 0.0 V, T_A = -40^\circ C \text{ to } +85^\circ C)$

Parameter	Symbol	Pin name	Conditions	Value*2		Unit	Remarks
				Min	Max		
Setup time between clearing interrupt and SCL rising	$t_{SU;INT}$	SCL0	R = 1.7 k Ω , C = 50 pF*1	$(nm / 2)t_{MCLK} - 20$	$(1 + nm / 2)t_{MCLK} + 20$	ns	Minimum value is applied to interrupt at 9th SCL $\bar{}$. Maximum value is applied to interrupt at 8th SCL $\bar{}$.
SCL clock "L" width	t_{LOW}	SCL0		$4 t_{MCLK} - 20$	—	ns	At reception
SCL clock "H" width	t_{HIGH}	SCL0		$4 t_{MCLK} - 20$	—	ns	At reception
Start condition detection	$t_{HD;STA}$	SCL0, SDA0		$2 t_{MCLK} - 20$	—	ns	Not detected when 1 t_{MCLK} is used at reception
Stop condition detection	$t_{SU;STO}$	SCL0, SDA0		$2 t_{MCLK} - 20$	—	ns	Not detected when 1 t_{MCLK} is used at reception
Restart condition detection condition	$t_{SU;STA}$	SCL0, SDA0		$2 t_{MCLK} - 20$	—	ns	Not detected when 1 t_{MCLK} is used at reception
Bus free time	t_{BUF}	SCL0, SDA0		$2 t_{MCLK} - 20$	—	ns	At reception
Data hold time	$t_{HD;DAT}$	SCL0, SDA0		$2 t_{MCLK} - 20$	—	ns	At slave transmission mode
Data setup time	$t_{SU;DAT}$	SCL0, SDA0		$t_{LOW} - 3 t_{MCLK} - 20$	—	ns	At slave transmission mode
Data hold time	$t_{HD;DAT}$	SCL0, SDA0		0	—	ns	At reception
Data setup time	$t_{SU;DAT}$	SCL0, SDA0		$t_{MCLK} - 20$	—	ns	At reception
SDA $\bar{}$ \emptyset SCL f (at wakeup function)	t_{WAKEUP}	SCL0, SDA0		Oscillation stabilization wait time + $2 t_{MCLK} - 20$	—	ns	

(Continued)

(Continued)

*1: R represents the pull-up resistor of the SCL0 and SDA0 lines, and C the load capacitor of the SCL0 and SDA0 lines.

*2: • See “(2) Source Clock/Machine Clock” for t_{MCLK} .

- m represents the CS4 bit and CS3 bit (bit4 and bit3) in the I²C clock control register (ICCR0).
- n represents the CS2 bit to CS0 bit (bit2 to bit0) in the I²C clock control register (ICCR0).
- The actual timing of I²C is determined by the values of m and n set by the machine clock (t_{MCLK}) and the CS4 to CS0 bits in the ICCR0 register.
- Standard-mode:
 - m and n can be set to values in the following range: $0.9 \text{ MHz} < t_{MCLK} \text{ (machine clock)} < 16.25 \text{ MHz}$.
 - The usable frequencies of the machine clock are determined by the settings of m and n as shown below.
 - (m, n) = (1, 8): $0.9 \text{ MHz} < t_{MCLK} \leq 1 \text{ MHz}$
 - (m, n) = (1, 22), (5, 4), (6, 4), (7, 4), (8, 4): $0.9 \text{ MHz} < t_{MCLK} \leq 2 \text{ MHz}$
 - (m, n) = (1, 38), (5, 8), (6, 8), (7, 8), (8, 8): $0.9 \text{ MHz} < t_{MCLK} \leq 4 \text{ MHz}$
 - (m, n) = (1, 98), (5, 22), (6, 22), (7, 22): $0.9 \text{ MHz} < t_{MCLK} \leq 10 \text{ MHz}$
 - (m, n) = (8, 22): $0.9 \text{ MHz} < t_{MCLK} \leq 16.25 \text{ MHz}$
- Fast-mode:
 - m and n can be set to values in the following range: $3.3 \text{ MHz} < t_{MCLK} \text{ (machine clock)} < 16.25 \text{ MHz}$.
 - The usable frequencies of the machine clock are determined by the settings of m and n as shown below.
 - (m, n) = (1, 8): $3.3 \text{ MHz} < t_{MCLK} \leq 4 \text{ MHz}$
 - (m, n) = (1, 22), (5, 4): $3.3 \text{ MHz} < t_{MCLK} \leq 8 \text{ MHz}$
 - (m, n) = (1, 38), (6, 4), (7, 4), (8, 4): $3.3 \text{ MHz} < t_{MCLK} \leq 10 \text{ MHz}$
 - (m, n) = (5, 8): $3.3 \text{ MHz} < t_{MCLK} \leq 16.25 \text{ MHz}$

18.5 A/D Converter

18.5.1 A/D Converter Electrical Characteristics

($V_{CC} = 1.8 \text{ V to } 3.6 \text{ V}$, $V_{SS} = 0.0 \text{ V}$, $T_A = -40^\circ\text{C to } +85^\circ\text{C}$)

Parameter	Symbol	Value			Unit	Remarks
		Min	Typ	Max		
Resolution	—	—	—	10	bit	
Total error		-3	—	+3	LSB	
Linearity error		-2.5	—	+2.5	LSB	
Differential linear error		-1.9	—	+1.9	LSB	
Zero transition voltage	V_{OT}	$AV_{SS} - 1.5 \text{ LSB}$	$AV_{SS} + 0.5 \text{ LSB}$	$AV_{SS} + 2.5 \text{ LSB}$	V	$2.7 \text{ V} \leq V_{CC} \leq 3.6 \text{ V}$
		$AV_{SS} - 0.5 \text{ LSB}$	$AV_{SS} + 1.5 \text{ LSB}$	$AV_{SS} + 3.5 \text{ LSB}$	V	$1.8 \text{ V} \leq V_{CC} < 2.7 \text{ V}$
Full-scale transition voltage	V_{FST}	$AV_{CC} - 3.5 \text{ LSB}$	$AV_{CC} - 1.5 \text{ LSB}$	$AV_{CC} + 0.5 \text{ LSB}$	V	$2.7 \text{ V} \leq V_{CC} \leq 3.6 \text{ V}$
		$AV_{CC} - 2.5 \text{ LSB}$	$AV_{CC} - 0.5 \text{ LSB}$	$AV_{CC} + 1.5 \text{ LSB}$	V	$1.8 \text{ V} \leq V_{CC} < 2.7 \text{ V}$
Compare time	—	0.6	—	140	μs	$2.7 \text{ V} \leq V_{CC} \leq 3.6 \text{ V}$
		20	—	140	μs	$1.8 \text{ V} \leq V_{CC} < 2.7 \text{ V}$
Sampling time	—	0.4	—	∞	μs	$2.7 \text{ V} \leq V_{CC} \leq 3.6 \text{ V}$, with external impedance $< 1.8 \text{ k}\Omega$
		30	—	∞	μs	$1.8 \text{ V} \leq V_{CC} < 2.7 \text{ V}$, with external impedance $< 14.8 \text{ k}\Omega$
Analog input current	I_{AIN}	-0.3	—	+0.3	μA	
Analog input voltage	V_{AIN}	AV_{SS}	—	AV_{CC}	V	

18.5.2 Notes on Using the A/D Converter

■ **External impedance of analog input and its sampling time**

- The A/D converter has a sample and hold circuit. If the external impedance is too high to keep sufficient sampling time, the analog voltage charged to the capacitor of the internal sample and hold circuit is insufficient, adversely affecting A/D conversion precision. Therefore, to satisfy the A/D conversion precision standard, considering the relationship between the external impedance and minimum sampling time, either adjust the register value and operating frequency or decrease the external impedance so that the sampling time is longer than the minimum value. In addition, if sufficient sampling time cannot be secured, connect a capacitor of about 0.1 μF to the analog input pin.

• Analog input equivalent circuit

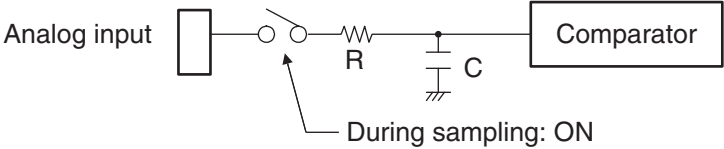

V _{CC}	R	C
2.7 V ≤ V _{CC} ≤ 3.6V	1.7 kΩ (Max)	14.5 pF (Max)
1.8 V ≤ V _{CC} < 2.7 V	8.4 kΩ (Max)	25.2 pF (Max)

Note: The values are reference values.

• Relationship between external impedance and minimum sampling time

[External impedance = 0 kΩ to 100 kΩ]

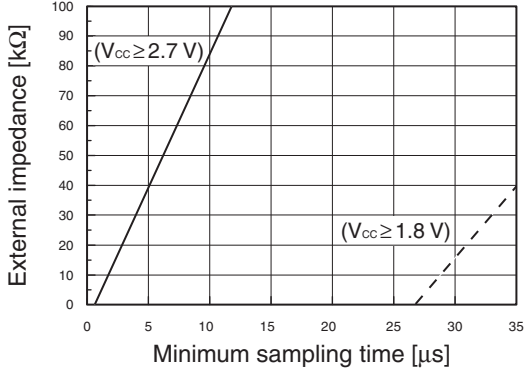

[External impedance = 0 kΩ to 20 kΩ]

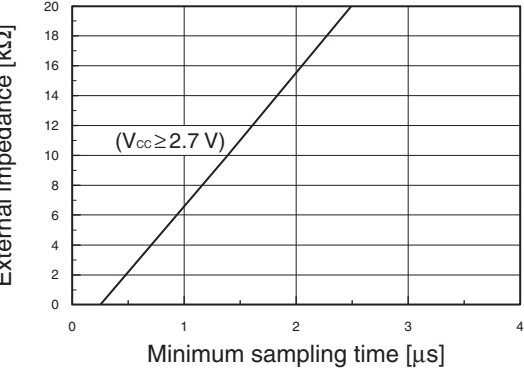

■ **A/D conversion error**

As $|V_{CC}-V_{SS}|$ decreases, the A/D conversion error increases proportionately.

18.5.3 Definitions of A/D Converter Terms

■ **Resolution**

It indicates the level of analog variation that can be distinguished by the A/D converter. When the number of bits is 10, analog voltage can be divided into $2^{10} = 1024$.

■ **Linearity error (unit: LSB)**

It indicates how much an actual conversion value deviates from the straight line connecting

the zero transition point (“00 0000 0000” ← → “00 0000 0001”) of a device to the full-scale transition point (“11 1111 1111” ← → “11 1111 1110”) of the same device.

■ **Differential linear error (unit: LSB)**

It indicates how much the input voltage required to change the output code by 1 LSB deviates from an ideal value.

■ **Total error (unit: LSB)**

It indicates the difference between an actual value and a theoretical value. The error can be caused by a zero transition error, a full-scale transition errors, a linearity error, a quantum error, or noise.

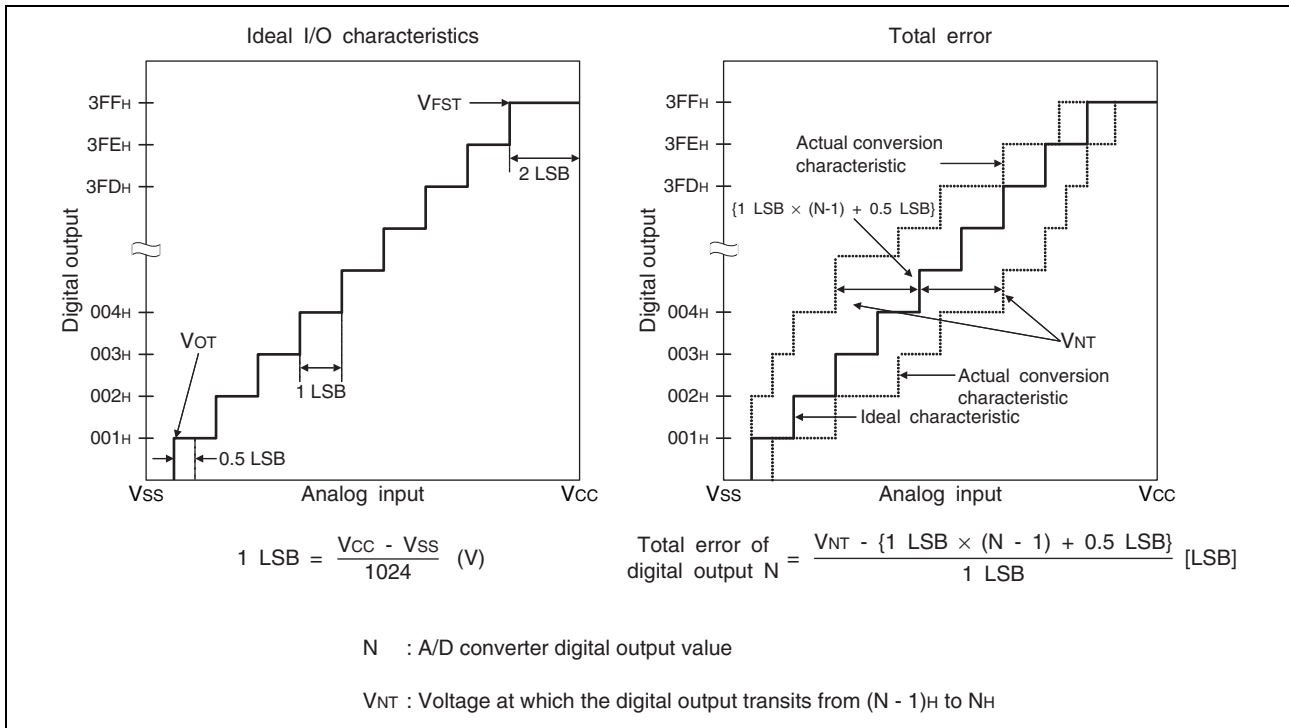

(Continued)

(Continued)

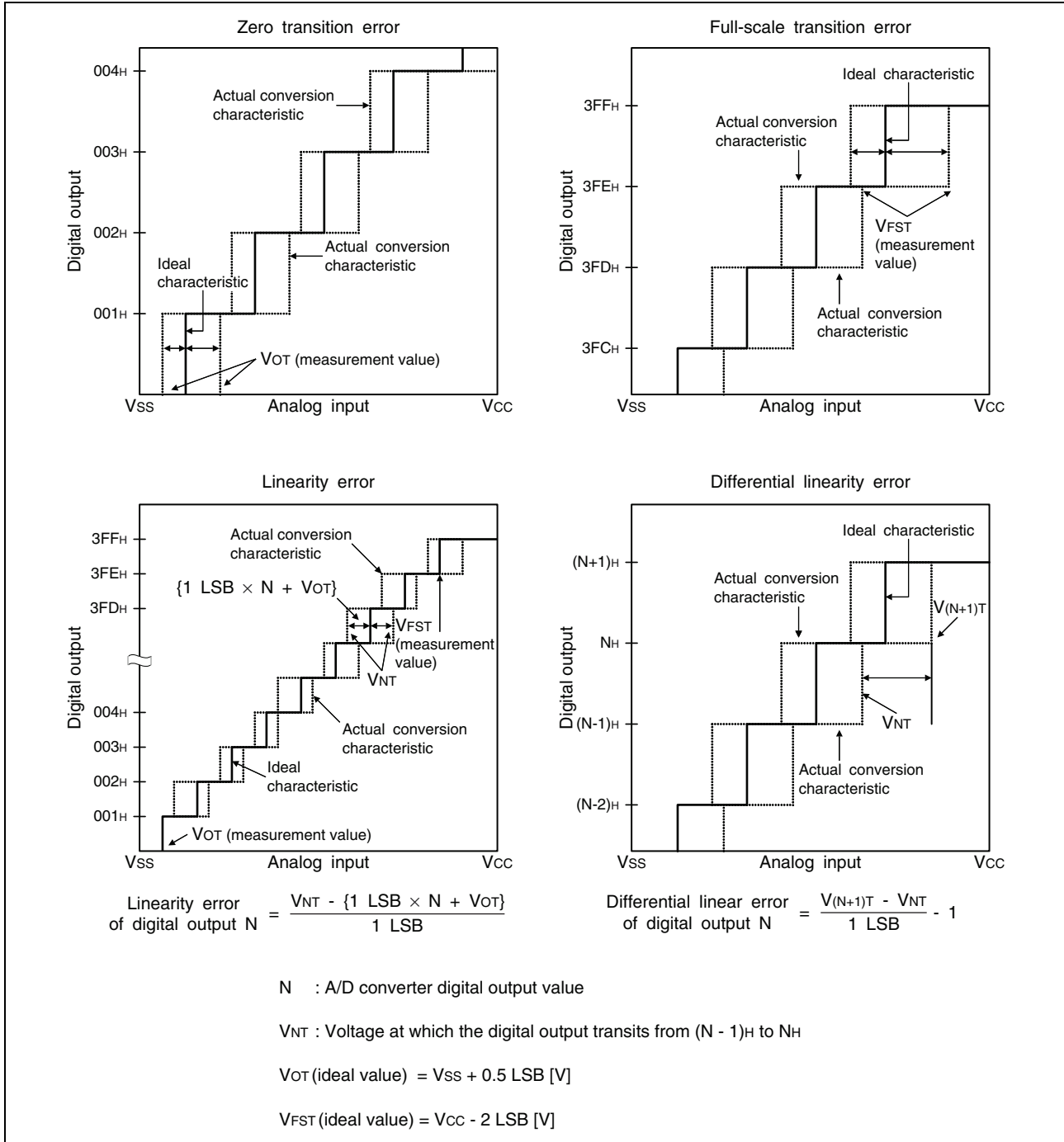

18.6 Flash Memory Program/Erase Characteristics

Parameter	Value			Unit	Remarks
	Min	Typ	Max		
Sector erase time (2 Kbyte sector)	—	0.2* ¹	0.5* ²	s	The time of programming 00 _H prior to erasure is excluded.
Sector erase time (16 Kbyte sector)	—	0.5* ¹	7.5* ²	s	The time of programming 00 _H prior to erasure is excluded.
Byte programming time	—	21	6100* ²	μs	System-level overhead is excluded.
Program/erase cycle	100000	—	—	cycle	
Power supply voltage at program/erase	2.7	3.0	3.6	V	
Flash memory data retention time	20* ³	—	—	year	Average T _A = +85°C

*1: T_A = +25°C, V_{CC} = 3.0 V, 100000 cycles

*2: T_A = +85°C, V_{CC} = 2.7 V, 100000 cycles

*3: This value is converted from the result of a technology reliability assessment. (The value is converted from the result of a high temperature accelerated test using the Arrhenius equation with the average temperature being +85°C).

19. Sample Characteristics

- Power supply current temperature characteristics

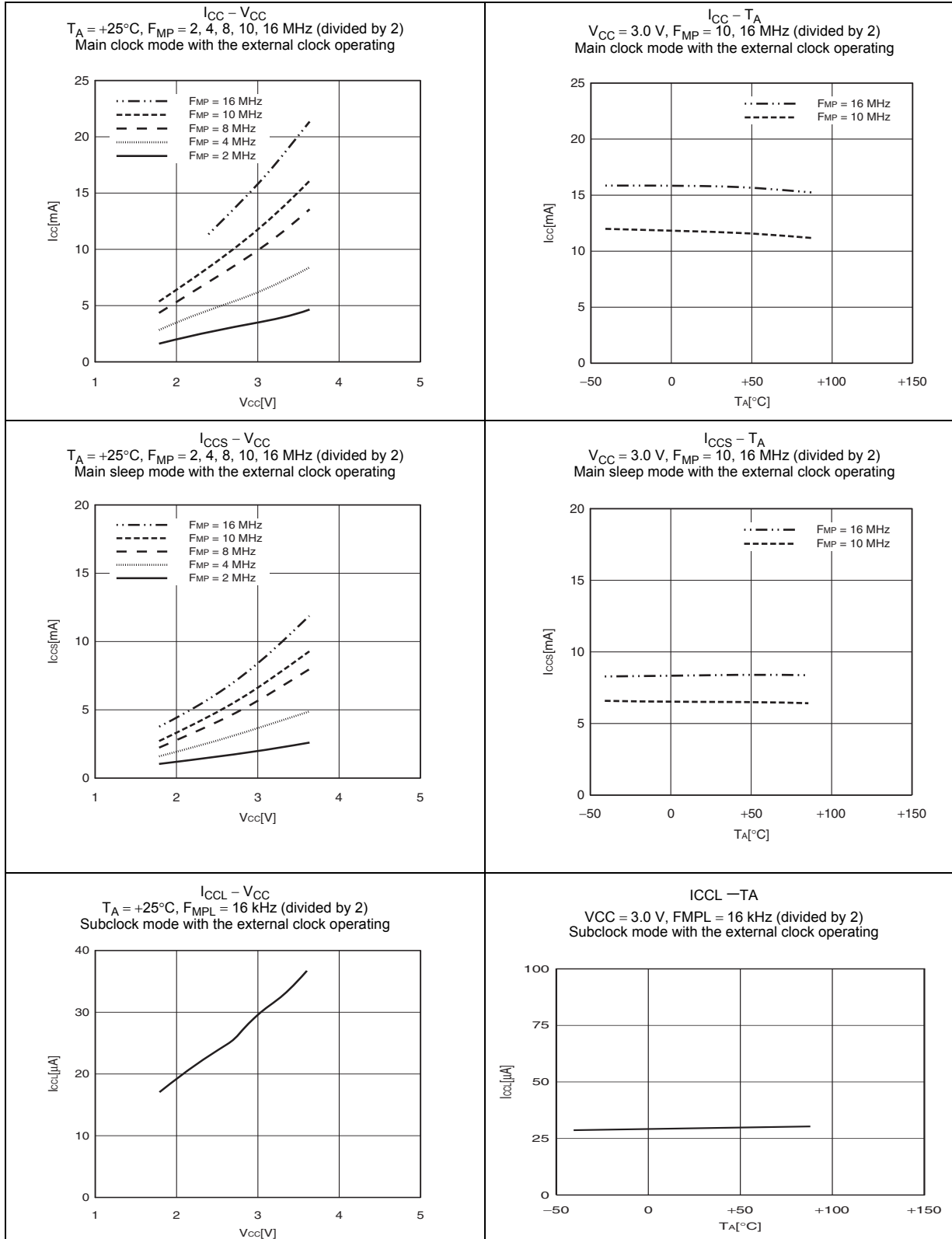

(Continued)

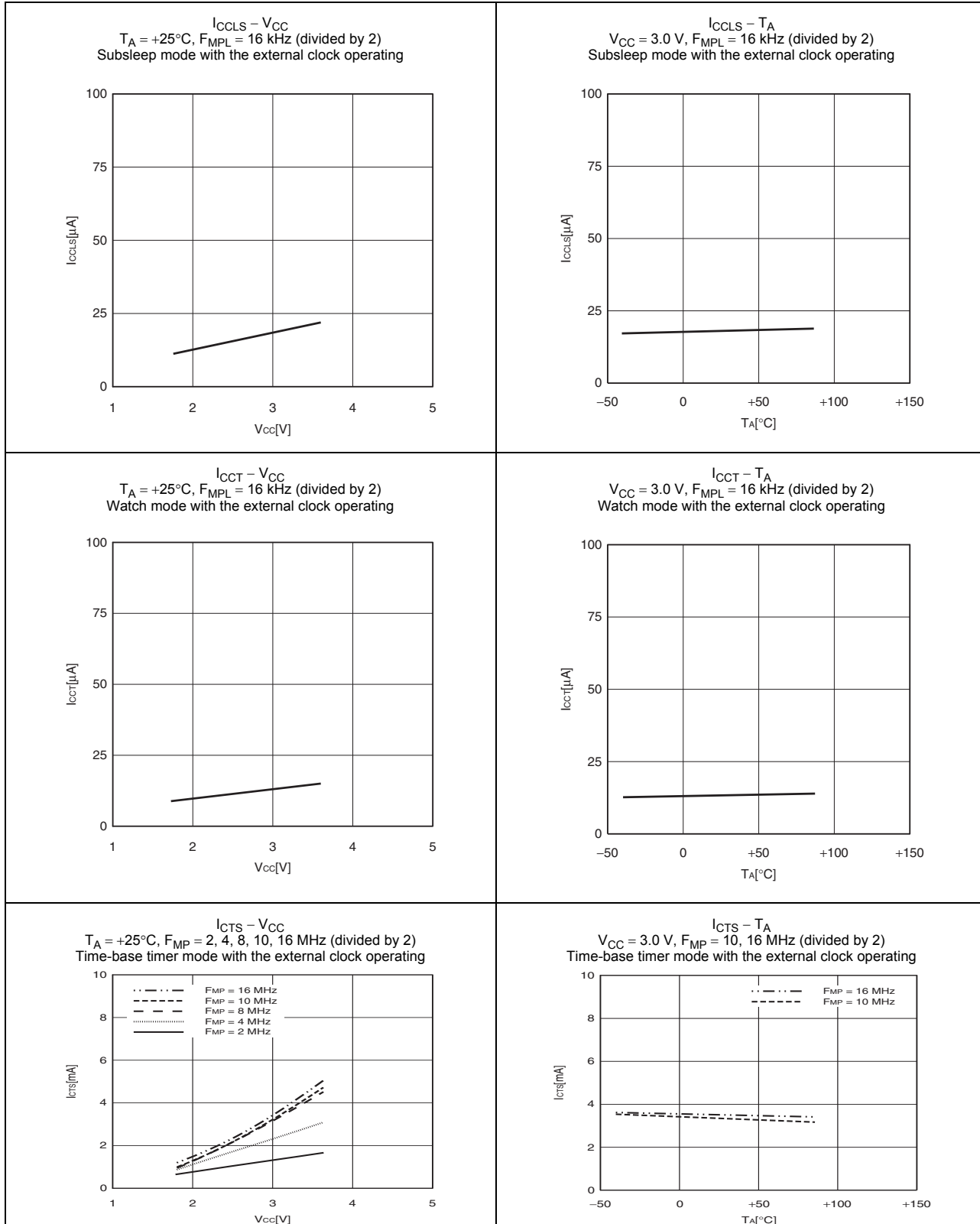

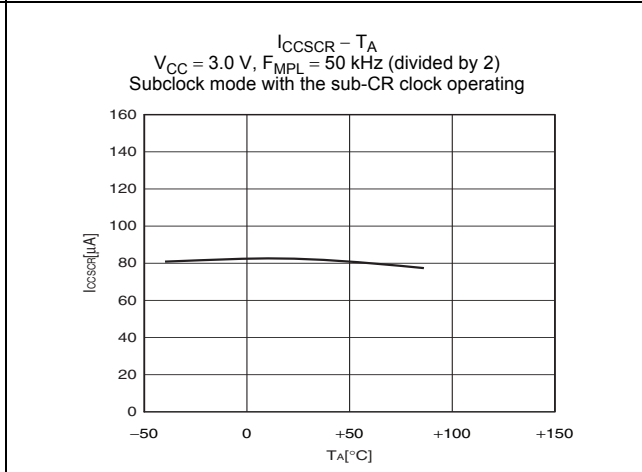
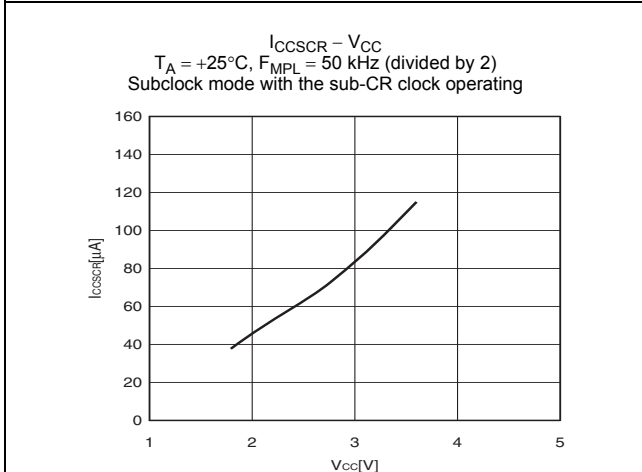
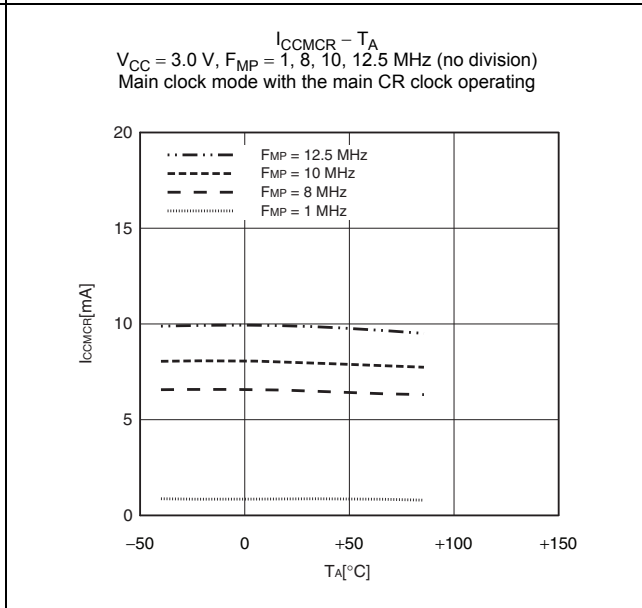
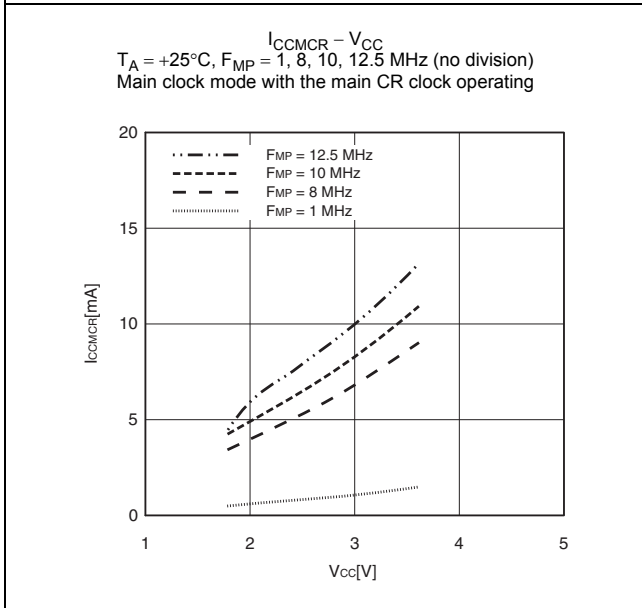
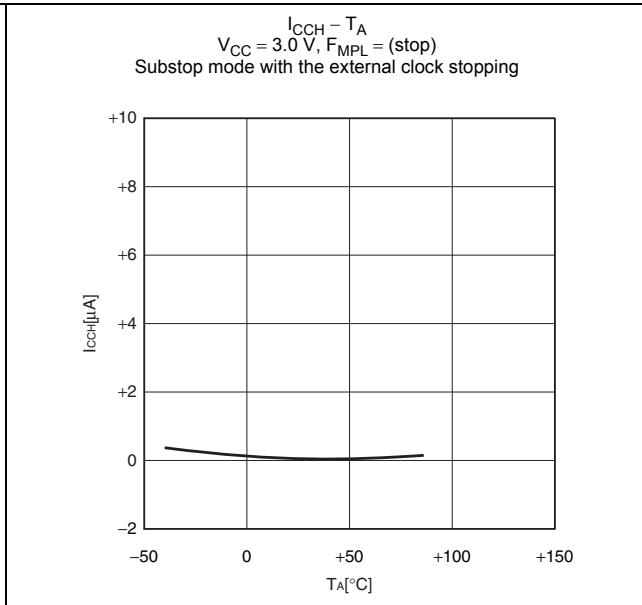
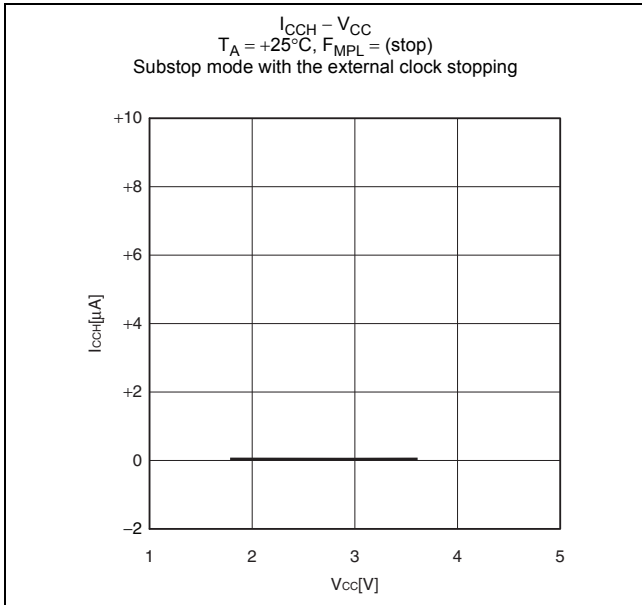

• Input voltage characteristics

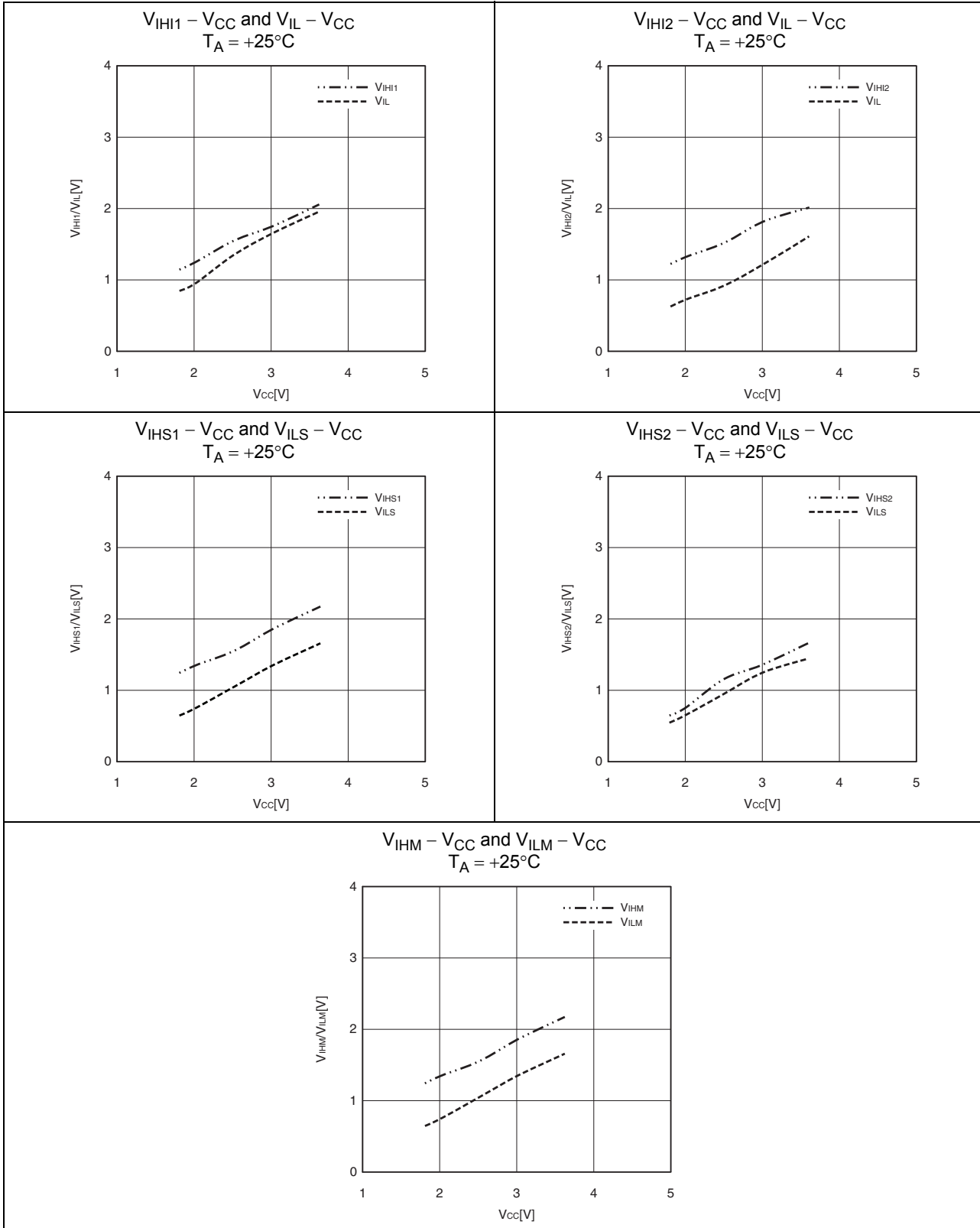

• Output voltage characteristics

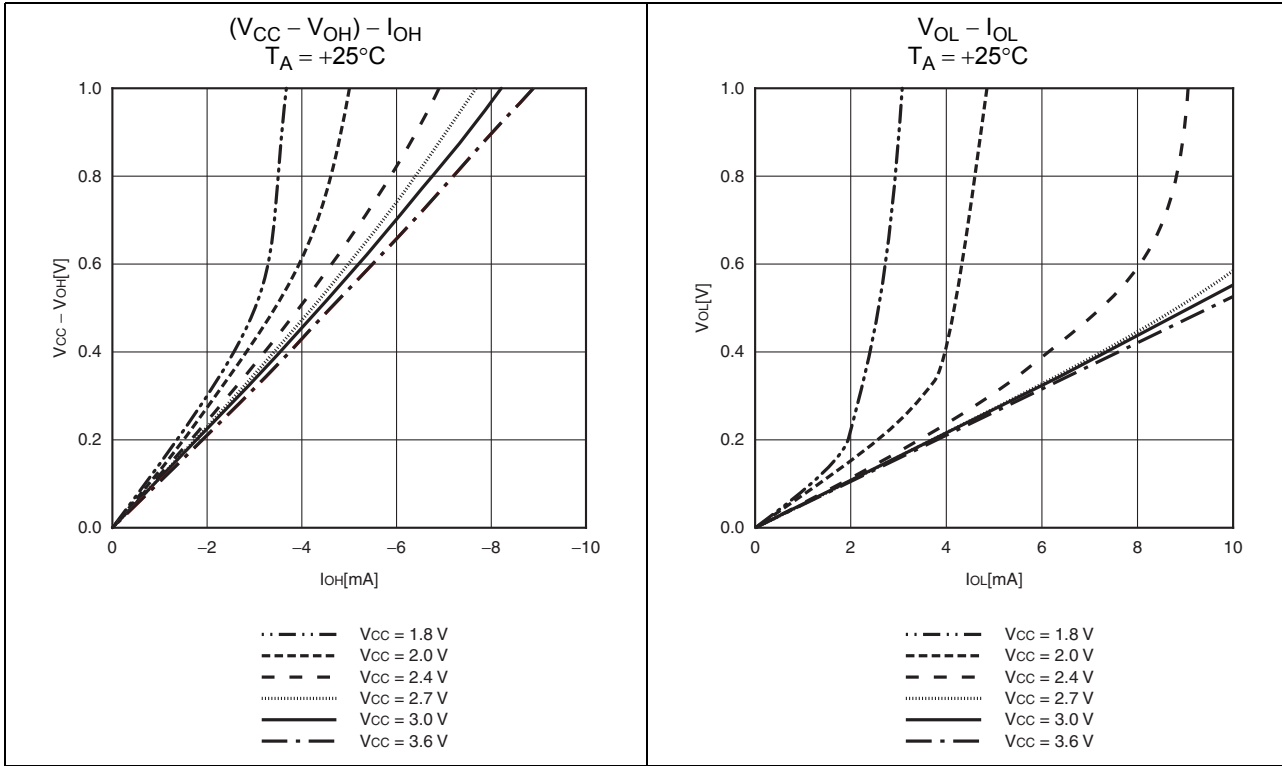

- Pull-up characteristics

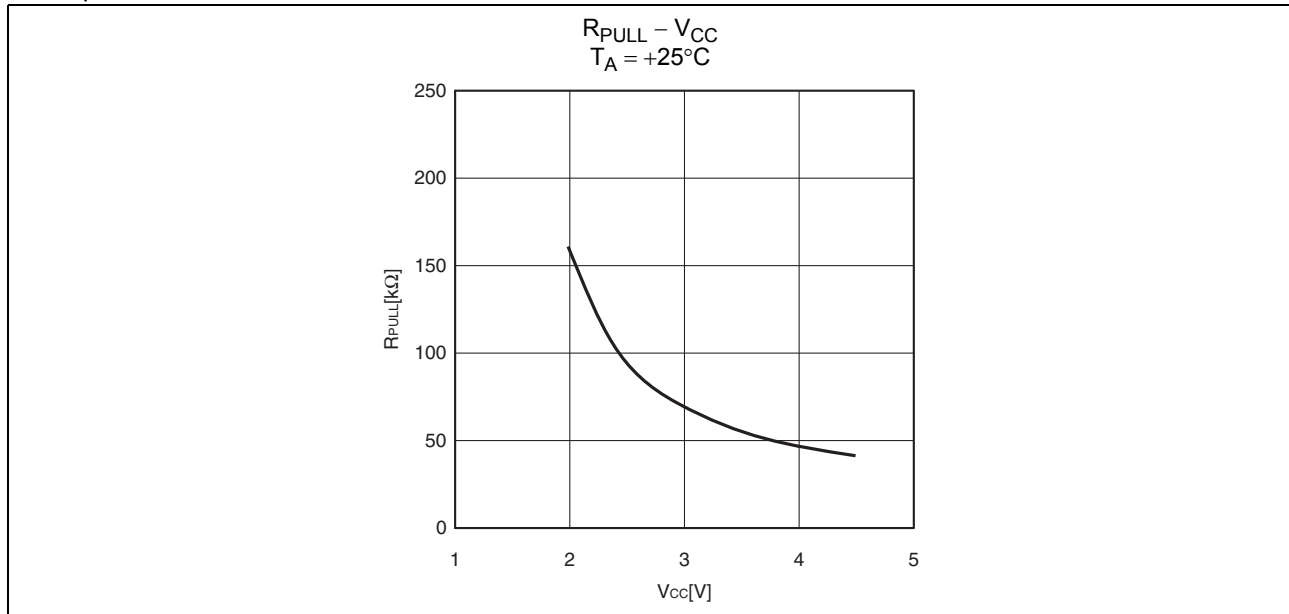

20. Mask Options

No.	Part Number	MB95F314E MB95F316E MB95F318E MB95F374E MB95F376E MB95F378E	MB95F314L MB95F316L MB95F318L MB95F374L MB95F376L MB95F378L
	Selectable/Fixed	Fixed	
1	Low-voltage detection reset	With low-voltage detection reset	Without low-voltage detection reset

21. Ordering Information

Part Number	Package
MB95F314EPMC-G-SNE2 MB95F314LPMC-G-SNE2 MB95F316EPMC-G-SNE2 MB95F316LPMC-G-SNE2 MB95F318EPMC-G-SNE2 MB95F318LPMC-G-SNE2	80-pin plastic LQFP (FPT-80P-M37)
MB95F374EPMC1-G-SNE2 MB95F374LPMC1-G-SNE2 MB95F376EPMC1-G-SNE2 MB95F376LPMC1-G-SNE2 MB95F378EPMC1-G-SNE2 MB95F378LPMC1-G-SNE2	64-pin plastic LQFP (FPT-64P-M38)

Part Number	Package
MB95F374EPMC2-G-SNE2 MB95F374LPMC2-G-SNE2 MB95F376EPMC2-G-SNE2 MB95F376LPMC2-G-SNE2 MB95F378EPMC2-G-SNE2 MB95F378LPMC2-G-SNE2	64-pin plastic LQFP (FPT-64P-M39)

22. Package Dimension

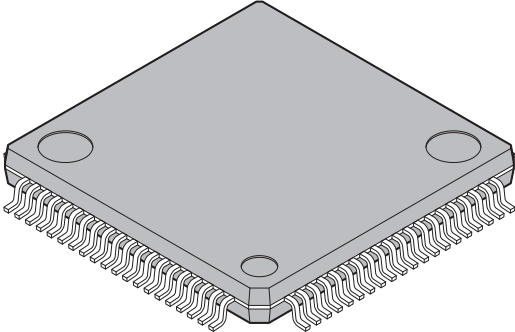
<p>80-pin plastic LQFP</p>  <p>(FPT-80P-M37)</p>	Lead pitch	0.50 mm
	Package width × package length	12.00 mm × 12.00 mm
	Lead shape	Gullwing
	Lead bend direction	Normal bend
	Sealing method	Plastic mold
	Mounting height	1.70 mm MAX
	Weight	0.47 g

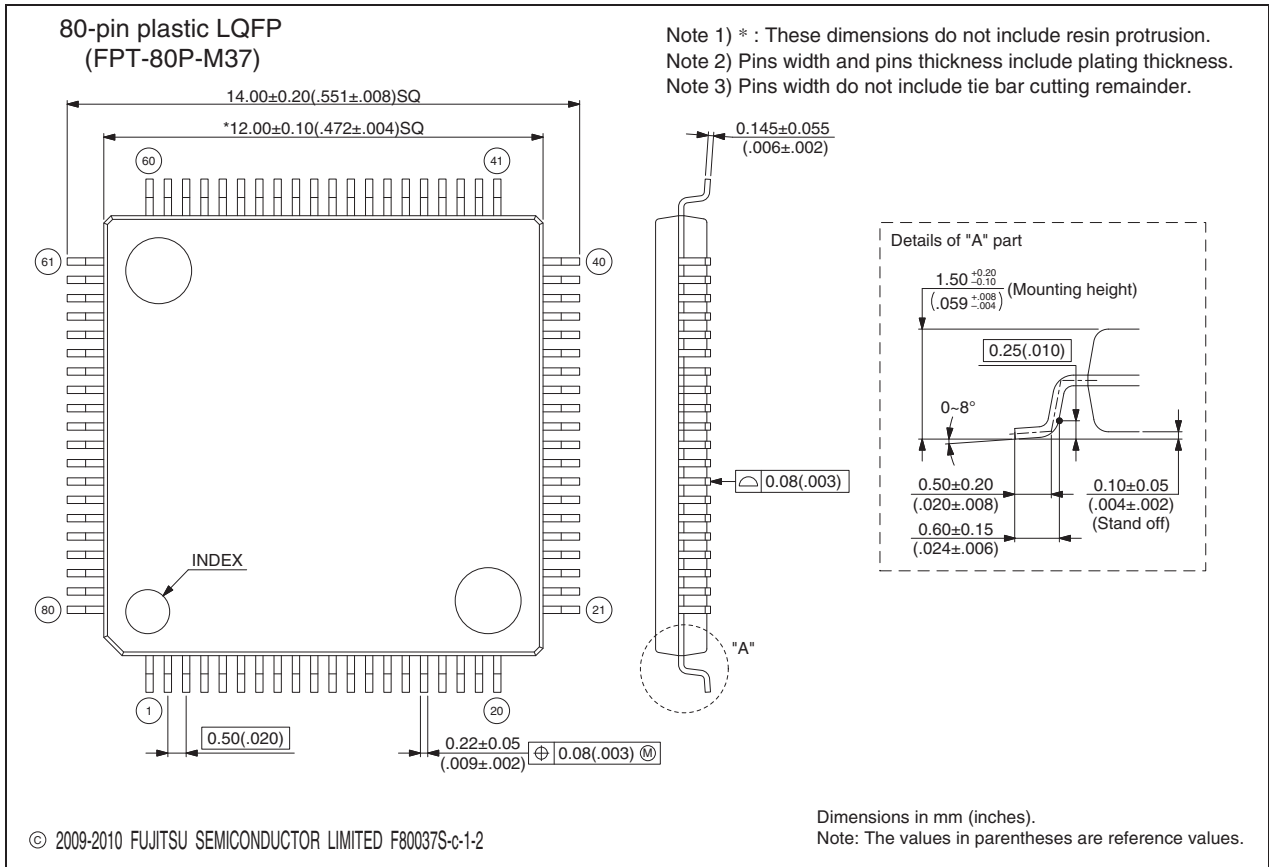

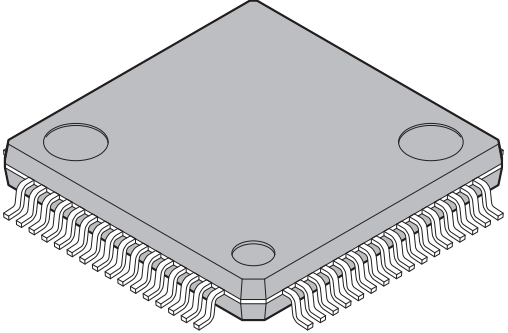
<p>64-pin plastic LQFP</p>  <p>(FPT-64P-M38)</p>	Lead pitch	0.50 mm
	Package width × package length	10.00 mm × 10.00 mm
	Lead shape	Gullwing
	Lead bend direction	Normal bend
	Sealing method	Plastic mold
	Mounting height	1.70 mm MAX
	Weight	0.32 g

64-pin plastic LQFP (FPT-64P-M38)

Note 1) * : These dimensions do not include resin protrusion.
 Note 2) Pins width and pins thickness include plating thickness.
 Note 3) Pins width do not include tie bar cutting remainder.

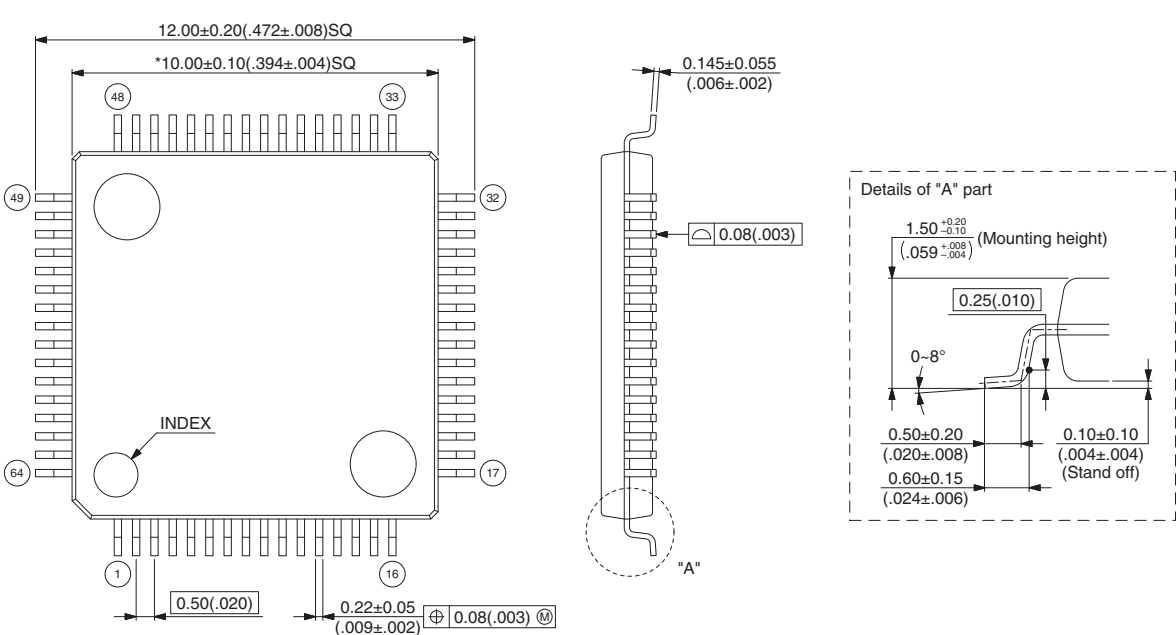

Top view dimensions:
 Overall width: 12.00 ± 0.20 (.472 ± .008) SQ
 Pin pitch: 10.00 ± 0.10 (.394 ± .004) SQ
 Pin pitch: 0.50 (.020)
 Pin thickness: 0.22 ± 0.05 (.009 ± .002)
 Pin width: 0.08 ± 0.003 @

Side view dimensions:
 Lead thickness: 0.145 ± 0.055 (.006 ± .002)
 Lead width: 0.08 ± 0.003

Details of "A" part:
 Mounting height: $1.50^{+0.20}_{-0.10}$ (.059 $^{+0.008}_{-.004}$)
 Lead width: 0.25 (.010)
 Lead angle: 0-8°
 Stand off: 0.10 ± 0.10 (.004 ± .004)
 Pin width: 0.50 ± 0.20 (.020 ± .008)
 Pin thickness: 0.60 ± 0.15 (.024 ± .006)

© 2010 FUJITSU SEMICONDUCTOR LIMITED F64038S-c-1-2

Dimensions in mm (inches).
 Note: The values in parentheses are reference values.

(Continued)

(Continued)

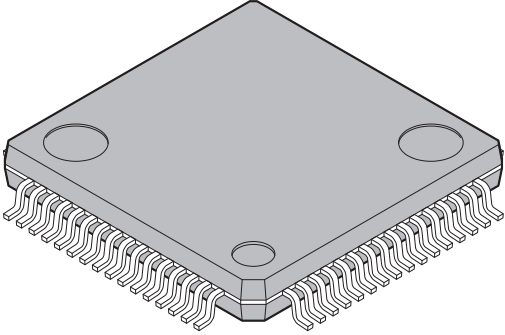
<p style="text-align: center;">64-pin plastic LQFP</p>  <p style="text-align: center;">(FPT-64P-M39)</p>	Lead pitch	0.65 mm
	Package width × package length	12.00 mm × 12.00 mm
	Lead shape	Gullwing
	Sealing method	Plastic mold
	Mounting height	1.70 mm MAX
	Weight	0.47 g

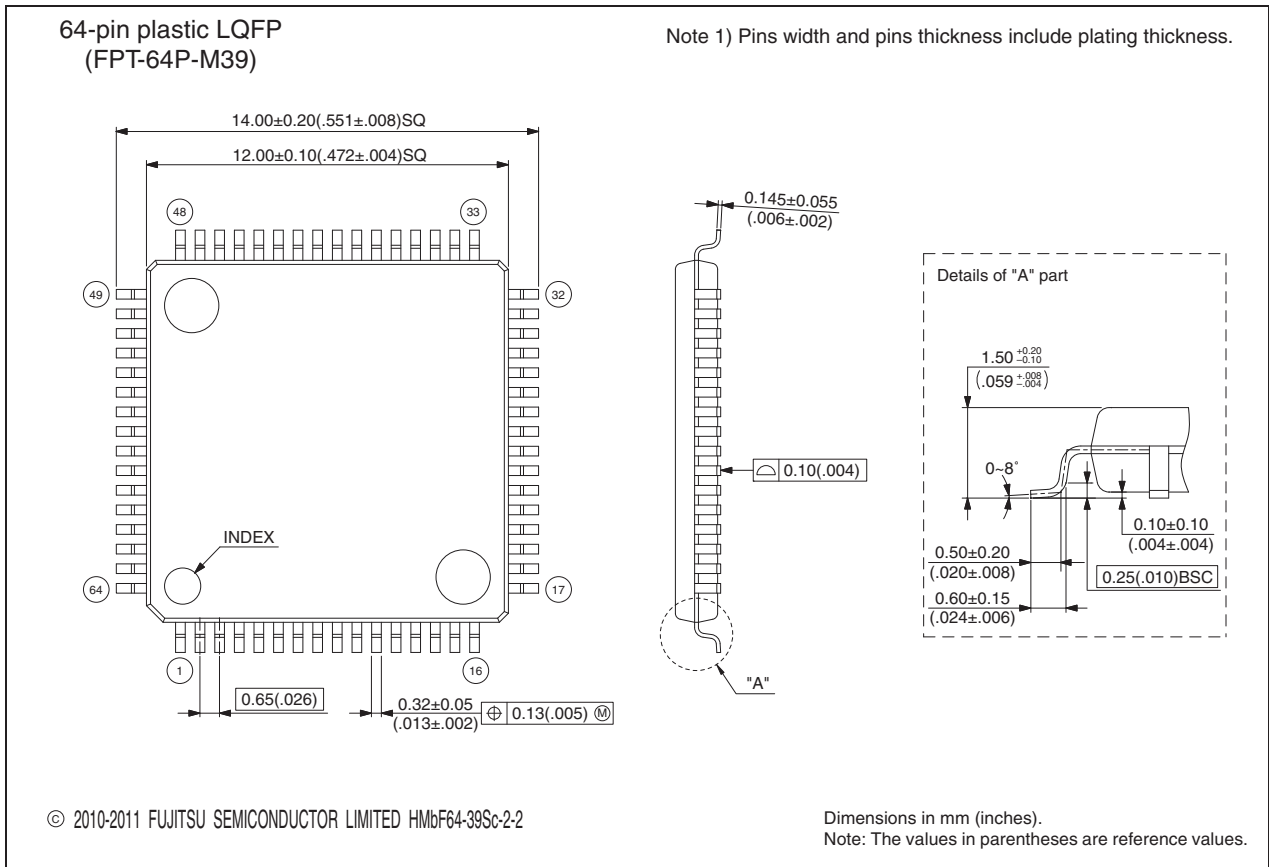

23. Major Changes

Spanion Publication Number: DS07-12628-2E

Page	Section	Details
1	—	Changed the family name. F ² MC-8FX → New 8FX
1	Features	Changed the main CR clock oscillation frequency. 1/8/10 MHz ±3%, maximum machine clock frequency: 10 MHz → 1/8/10/12.5 MHz ±2%, maximum machine clock frequency: 12.5 MHz
23	Pin Connection	Added “• Notes on handling the external clock pins while using the CR clock”.
46	Electrical Characteristics DC Characteristics	Changed the condition for the power supply current (I _{CCMCR}). F _{CRH} = 10 MHz F _{MP} = 10 MHz Main CR clock mode → F _{CRH} = 12.5 MHz F _{MP} = 12.5 MHz Main CR clock mode Changed the condition for the power supply current (I _{CCSCR}). F _{CL} = 32 kHz F _{MPL} = 16 kHz Sub-CR clock mode (divided by 2) T _A = +25°C → Sub-CR clock mode (divided by 2) T _A = +25°C
47		Changed the condition for the power supply current (I _{CRH}). Current consumption for the main CR oscillator at 10 MHz → Current consumption for the main CR oscillator
48	Electrical Characteristics AC Characteristics Clock Timing	Changed the values of the clock frequency (F _{CRH}).
58	Electrical Characteristics AC Characteristics Low-voltage Detection	Deleted the following parameters: Power hysteresis width 0, Power hysteresis width 1, Power hysteresis width 2, Interrupt hysteresis width 0, Interrupt hysteresis width 1, Interrupt hysteresis width 2, Interrupt hysteresis width 3, Interrupt hysteresis width 4
59		Deleted V _{PHYS} /V _{IHYS} from the diagram.
64	Electrical Characteristics AC Characteristics I ² C Timing	Changed the settings related to the machine clock shown in *2.
70 to 75	Sample Characteristics	Added “■ SAMPLE CHARACTERISTICS”.

NOTE: Please see “Document History” about later revised information.

Document History

Document Title: MB95F314E/F314L/F316E/F316L/F318E/F318L, MB95F374E/F374L/F376E/F376L/F378E/F378L, New 8FX MB95310L/370L Series 8-bit Microcontrollers Document Number: 002-07519				
Revision	ECN	Orig. of Change	Submission Date	Description of Change
**	—	AKIH	08/13/2010	Migrated to Cypress and assigned document number 002-07519. No change to document contents or format.
*A	5180514	AKIH	04/06/2016	Updated to Cypress template

Sales, Solutions, and Legal Information

Worldwide Sales and Design Support

Cypress maintains a worldwide network of offices, solution centers, manufacturer's representatives, and distributors. To find the office closest to you, visit us at [Cypress Locations](#).

Products

ARM® Cortex® Microcontrollers	cypress.com/arm
Automotive	cypress.com/automotive
Clocks & Buffers	cypress.com/clocks
Interface	cypress.com/interface
Lighting & Power Control	cypress.com/powerpsoc
Memory	cypress.com/memory
PSoC	cypress.com/psoc
Touch Sensing	cypress.com/touch
USB Controllers	cypress.com/usb
Wireless/RF	cypress.com/wireless

PSoC® Solutions

cypress.com/psoc
PSoC 1 | PSoC 3 | PSoC 4 | PSoC 5LP

Cypress Developer Community

[Community](#) | [Forums](#) | [Blogs](#) | [Video](#) | [Training](#)

Technical Support

cypress.com/support

© Cypress Semiconductor Corporation 2010-2016. This document is the property of Cypress Semiconductor Corporation and its subsidiaries, including Spansion LLC ("Cypress"). This document, including any software or firmware included or referenced in this document ("Software"), is owned by Cypress under the intellectual property laws and treaties of the United States and other countries worldwide. Cypress reserves all rights under such laws and treaties and does not, except as specifically stated in this paragraph, grant any license under its patents, copyrights, trademarks, or other intellectual property rights. If the Software is not accompanied by a license agreement and you do not otherwise have a written agreement with Cypress governing the use of the Software, then Cypress hereby grants you under its copyright rights in the Software, a personal, non-exclusive, nontransferable license (without the right to sublicense) (a) for Software provided in source code form, to modify and reproduce the Software solely for use with Cypress hardware products, only internally within your organization, and (b) to distribute the Software in binary code form externally to end users (either directly or indirectly through resellers and distributors), solely for use on Cypress hardware product units. Cypress also grants you a personal, non-exclusive, nontransferable, license (without the right to sublicense) under those claims of Cypress's patents that are infringed by the Software (as provided by Cypress, unmodified) to make, use, distribute, and import the Software solely to the minimum extent that is necessary for you to exercise your rights under the copyright license granted in the previous sentence. Any other use, reproduction, modification, translation, or compilation of the Software is prohibited.

CYPRESS MAKES NO WARRANTY OF ANY KIND, EXPRESS OR IMPLIED, WITH REGARD TO THIS DOCUMENT OR ANY SOFTWARE, INCLUDING, BUT NOT LIMITED TO, THE IMPLIED WARRANTIES OF MERCHANTABILITY AND FITNESS FOR A PARTICULAR PURPOSE. Cypress reserves the right to make changes to this document without further notice. Cypress does not assume any liability arising out of the application or use of any product or circuit described in this document. Any information provided in this document, including any sample design information or programming code, is provided only for reference purposes. It is the responsibility of the user of this document to properly design, program, and test the functionality and safety of any application made of this information and any resulting product. Cypress products are not designed, intended, or authorized for use as critical components in systems designed or intended for the operation of weapons, weapons systems, nuclear installations, life-support devices or systems, other medical devices or systems (including resuscitation equipment and surgical implants), pollution control or hazardous substances management, or other uses where the failure of the device or system could cause personal injury, death, or property damage ("Unintended Uses"). A critical component is any component of a device or system whose failure to perform can be reasonably expected to cause the failure of the device or system, or to affect its safety or effectiveness. Cypress is not liable, in whole or in part, and Company shall and hereby does release Cypress from any claim, damage, or other liability arising from or related to all Unintended Uses of Cypress products. Company shall indemnify and hold Cypress harmless from and against all claims, costs, damages, and other liabilities, including claims for personal injury or death, arising from or related to any Unintended Uses of Cypress products.

Cypress, the Cypress logo, Spansion, the Spansion logo, and combinations thereof, PSoC, CapSense, EZ-USB, F-RAM, and Traveo are trademarks or registered trademarks of Cypress in the United States and other countries. For a more complete list of Cypress trademarks, visit cypress.com. Other names and brands may be claimed as property of their respective owners.

Looking for pricing, stock, or lifecycle information?

Click below to explore more details on WIN SOURCE:

- ⊖ [View MB95F374LPMC1-G-SNE2 on WIN SOURCE](#)
- ⊖ [Infineon Technologies](#) Information

Optimize Your Supply Chain with WIN SOURCE Solutions

- ✓ Global Sourcing Solution
- ✓ Obsolete Management
- ✓ Cost Control Management
- ✓ Shortage Management
- ✓ Alternative Solution
- ✓ Excess Inventory Management