



**THE DATASHEET OF
MAX9547ESA+T**



General Description

The MAX9546/MAX9547 differential interface chipset converts single-ended voltages to differential voltages for transport and then converts back to single-ended voltages. These devices eliminate costly, bulky, single-ended coaxial cables with inexpensive, readily available, differential shielded (ScTP) or unshielded (UTP) twisted pairs. The fault detection of the MAX9546 and loss-of-signal detection of the MAX9547 allow proactive and speedy diagnosis, such as identifying failures in the manufacturing stage and troubleshooting equipment at repair facilities. The MAX9546/MAX9547 are low-cost, convenient solutions for transporting CVBS/FBAS analog video signals (PAL or NTSC) through hostile environments.

The MAX9546 driver converts the single-ended input into a differential output with a 6dB fixed gain to drive a back-terminated, DC-coupled differential video output to unity gain. This DC connection allows the detection of a short-circuit condition at the differential outputs. The FAULT output indicates a short-circuit condition including a short to a high battery condition ($V_{BAT} = +16V$) or ground.

The MAX9547 receiver converts the differential signal from the MAX9546 into a single-ended signal. Like the MAX9546 output, the MAX9547 input survives a short to a high battery condition or ground. The MAX9547 receiver loss-of-signal output (LOS) operates by detecting the H-Sync and thus can support both monochrome and color video signals. The MAX9547 gain is set with an external impedance between ZT+ and ZT-.

The MAX9546/MAX9547 operate from a 7.5V to 10V single supply. Both devices include $\pm 15kV$ ESD Human Body Model (HBM) protection. The MAX9546/MAX9547 are offered in a thermally enhanced 8-pin SO package and specified over the $-40^{\circ}C$ to $+85^{\circ}C$ extended temperature range.

Applications

- Security/CCTV Video
- Avionics/In-Flight Entertainment

Features

- Fault Detection (MAX9546)
- Loss-of-Signal Detection (MAX9547)
- Tolerate $\pm 2V$ Ground-Level Shift between Source and Load
- $\pm 15kV$ ESD Protection (Human Body Model)
- $\pm 8kV$ -IEC 1000-4-2 Contact Discharge
- $\pm 15kV$ -IEC 1000-4-2 Air-Gap Discharge
- Preset 6dB Gain (MAX9546)
- Variable Receiver Gain (MAX9547)
- 7.5V to 10V Single-Supply Operation

Ordering Information

PART	PIN-PACKAGE	PKG CODE	DESCRIPTION
MAX9546ESA+	8 SO-EP*	S8E-14	Driver
MAX9547ESA+	8 SO-EP*	S8E-14	Receiver

Note: These devices are specified for $-40^{\circ}C$ to $+85^{\circ}C$ temperature range.

+Denotes a lead-free package.

*EP = Exposed paddle.

Pin Configuration appears at end of data sheet.

Typical Operating Circuit

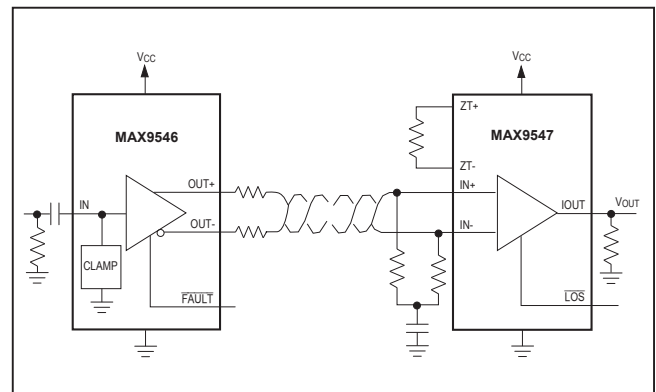

Absolute Maximum Ratings

(Voltages are referenced GND.)

V_{CC} to GND.....	-0.3V to +11V
IN and $\overline{\text{FAULT}}$ (MAX9546)	-0.3V to ($V_{CC} + 0.3V$)
OUT+, OUT- (MAX9546) (Note 1).....	-2V to +16V
$\overline{\text{FAULT}}$ Short-Circuit Duration to	
V_{CC} or GND (MAX9546)	Continuous
IN+, IN- (MAX9547) (Note 1)	-2V to +16V
IOUT, $\overline{\text{LOS}}$, ZT+, ZT- (MAX9547).....	-0.3V to ($V_{CC} + 0.3V$)
Differential Input Voltage ($ V_{IN+} - V_{IN-} $) (MAX9547).....	+5V

IOUT, $\overline{\text{LOS}}$ Short-Circuit Duration to	
V_{CC} or GND (MAX9547)	Continuous
Continuous Power Dissipation ($T_A = +70^\circ\text{C}$)	
8-Pin SO-EP (derate 24.4mW/ $^\circ\text{C}$ above +70 $^\circ\text{C}$)....	1951.2mW
θ_{JC} (Note 2)	7.0 $^\circ\text{C}/\text{W}$
θ_{JA}	41.0 $^\circ\text{C}/\text{W}$
Operating Temperature Range.....	-40 $^\circ\text{C}$ to +85 $^\circ\text{C}$
Junction Temperature	+150 $^\circ\text{C}$
Storage Temperature Range	-65 $^\circ\text{C}$ to +150 $^\circ\text{C}$
Lead Temperature (soldering, 10s)	+300 $^\circ\text{C}$

Note 1: The Absolute Maximum Ratings of OUT+/OUT- for the MAX9546 and IN+/IN- for the MAX9547 are based on a single-fault condition, i.e. only one output of MAX9546 (or both outputs together) is shorted to the battery, V_{CC} or GND. The devices will not survive a double-fault condition, i.e. OUT+ and OUT- shorted to different supplies.

Note 2: Package thermal resistances were obtained using the method described in JEDEC specification JESD51-7, using a four-layer board. For detailed information on package thermal considerations, refer to www.maximintegrated.com/thermal-tutorial.

Stresses beyond those listed under "Absolute Maximum Ratings" may cause permanent damage to the device. These are stress ratings only, and functional operation of the device at these or any other conditions beyond those indicated in the operational sections of the specifications is not implied. Exposure to absolute maximum rating conditions for extended periods may affect device reliability.

DC Electrical Characteristics—MAX9546

($V_{CC} = +8.5V$, $R_L = 220\Omega$ between OUT+ and OUT-, $T_A = -40^\circ\text{C}$ to +85 $^\circ\text{C}$. Typical values are at $T_A = +25^\circ\text{C}$, unless otherwise noted.) (Note 3)

PARAMETER	SYMBOL	CONDITIONS	MIN	TYP	MAX	UNITS
Supply Voltage Range	V_{CC}	Guaranteed by PSRR	7.5	8.5	10.0	V
Quiescent Supply Current	I_{CC}	No load		64	112	mA
Voltage Gain	A_V	$V_{IN} = 1.2V_{P-P}$ (Note 4)	1.8	2	2.2	V/V
Input-Voltage Swing	V_{IN}	Guaranteed by A_V			1.2	V_{P-P}
Input Clamp Voltage	V_{CLMP}	(Note 5)		3.46		V
Input Clamp Current	I_{CLMP}	(Note 5)		7	13	μA
Input Resistance	R_{IN}	(Notes 5, 6)		500		k Ω
Output Common-Mode Voltage	V_{COM}		3.0	3.25	3.4	V
Output Impedance	R_{OUT}			0.1		Ω
Output Fault Current	$I_{F(OUT)}$	OUT+ and/or OUT- to +16V		9		mA
		OUT+ and/or OUT- to + ($V_{CC} - 2V$)		2		
		OUT+ and/or OUT- to +2V		4		
		OUT+ and/or OUT- to -2V		7		
		OUT+ and/or OUT- to +16V, V_{CC} unconnected		6		
		OUT+ or OUT- to -2V, V_{CC} unconnected		24		
Power-Supply Rejection Ratio	PSRR	V_{CC} from 7.5V to 10V (Note 7)	Differential mode	45	62	dB
			Common mode	46	52	
$\overline{\text{FAULT}}$ Output Logic Level		V_{OL} , $I_{SINK} = 1.6\text{mA}$ (Note 8)			0.4	V
$\overline{\text{FAULT}}$ Output Leakage Current				0.01		μA

AC Electrical Characteristics—MAX9546

($V_{CC} = +8.5V$, $R_L = 220\Omega$ across OUT+ and OUT-, $T_A = -40^\circ C$ to $+85^\circ C$. Typical values are at $T_A = +25^\circ C$, unless otherwise noted.) (Note 3)

PARAMETER	SYMBOL	CONDITIONS	MIN	TYP	MAX	UNITS
Large-Signal Bandwidth		$V_{IN} = 1V_{P-P}$, -3dB		18		MHz
Large-Signal Flatness		$V_{IN} = 1V_{P-P}$, $\pm 0.5dB$		15		MHz
Slew Rate	SR	OUT+ - OUT-		70		V/ μs
Settling Time (0.1%)	$t_{SETTLING}$	$V_{IN} = 1V_{P-P}$		400		ns
Power-Supply Rejection Ratio	PSRR	$f = 100kHz$, 100mV $_{P-P}$ ripple		63		dB
Common-Mode Balance (Note 9)	CMB	$f = 100kHz$		55		dB
		$f = 3.58MHz$		39		
Droop		Guaranteed by input current		1		%
Differential Gain	DG	(Note 10)		1.37		%
Differential Phase	DP	(Note 10)		0.14		degrees
SNR (dB $_{RMS}$)	SNR	(Note 10)		-62		dB
2T Pulse to Bar Rating		(Note 10)		-0.22		%KF
2T Pulse Response		(Note 10)		0.30		%KF
Group Delay	D/dt	At 3.58MHz (Note 10)		2.20		ns
Horizontal Tilt		(Notes 10, 15)		0		%
Vertical Tilt		(Notes 10, 15)		6.62		%

DC Electrical Characteristics—MAX9547

($V_{CC} = +8.5V$, GND = 0V, $R_L = 75\Omega$, $Z_{ZT} = 75\Omega$, $T_A = -40^\circ C$ to $+85^\circ C$. Typical values are at $T_A = +25^\circ C$.) (Note 3)

PARAMETER	SYMBOL	CONDITIONS	MIN	TYP	MAX	UNITS
Supply Voltage Range	V_{CC}	Guaranteed by PSRR	7.5	8.5	10.0	V
Supply Current	I_{CC}			70	110	mA
Differential Input Voltage Range $ IN+ - IN- $	$V_{IN(P-P)}$	Guaranteed by CMRR (Note 11)			1.2	V_{P-P}
Common-Mode Input Voltage Range	V_{COM}	Guaranteed by CMRR (Note 11)	1.0		5.4	V
Input Current	I_{IN}			6	30	μA
Input Offset Current	ΔI_{IN}			1	4.2	μA
Input Resistance	R_{IN}	Differential		80		k Ω
Voltage Gain	A_V	$V_{IN(P-P)} = 1.2V$, defined as $I_{OUT} \times (R_L / V_{IN})$	0.90	1	1.15	V/V
Output Voltage	V_{OB}	$IN+ = IN- = 3.2V$		1		V
Output Voltage Swing	V_{OUT}				1.2	V_{P-P}
Maximum Output Current	I_{OUT}	$V_{IN} = 1V$, $Z_{ZT} = 0$		21		mA
Power-Supply Rejection Ratio	PSRR	V_{CC} from 7.5V to 10V	26	34		dB
Common-Mode Rejection Ratio	CMRR	$1V \leq V_{COM} \leq 5.4V$	42	54		dB
		$2V \leq V_{COM} \leq 4.4V$	46	70		

DC Electrical Characteristics—MAX9547 (continued)(V_{CC} = +8.5V, GND = 0V, R_L = 75Ω, Z_{ZT} = 75Ω, T_A = -40°C to +85°C. Typical values are at T_A = +25°C.) (Note 3)

PARAMETER	SYMBOL	CONDITIONS	MIN	TYP	MAX	UNITS
LOS Logic Level		V _{OL} , I _{SINK} = 1.6mA (Note 12)			0.4	V
LOS Leakage Current				0.01		μA
Input Fault Current	I _F	IN+ and/or IN- to +16V, R _{T1} + R _{T2} = 110Ω		50		mA
		IN+ and/or IN- to -2V, R _{T1} + R _{T2} = 110Ω		10		
		IN+ and/or IN- to +16V, V _{CC} unconnected, R _{T1} + R _{T2} = 110Ω		72		
		IN+ and/or IN- to -2V, V _{CC} unconnected, R _{T1} + R _{T2} = 110Ω		10		

AC Electrical Characteristics—MAX9547(V_{CC} = +8.5V, GND = 0V, R_L = 75Ω, Z_{ZT} = 75Ω, C_L = 50pF, T_A = -40°C to +85°C, Typical values are at T_A = +25°C.) (Note 3)

PARAMETER	SYMBOL	CONDITIONS	MIN	TYP	MAX	UNITS
Large-Signal Bandwidth		V _{IN} = 1V _{P-P} , -3dB		20		MHz
Large-Signal Flatness		V _{IN} = 1V _{P-P} , ±0.5dB		15		MHz
Slew Rate	SR			50		V/μs
Settling Time (0.1%)	t _{SETTLING}			400		ns
Power-Supply Rejection Ratio	PSRR	f = 100kHz, 100mV _{P-P} ripple		30		dB
Common-Mode Rejection Ratio	CMRR	f = 100kHz, 100mV _{P-P} ripple		53		dB
LOS Timeout Period	t _{LOS}			760		μs
Differential Gain	DG	(Notes 13, 14)		2.65		%
Differential Phase	DP	(Notes 13, 14)		0.57		degrees
SNR (dB _{RMS})	SNR	(Notes 13, 14)		-72		dB
2T Pulse to Bar Rating		(Notes 13, 14)		-0.06		%KF
2T Pulse Response		(Notes 13, 14)		0.40		%KF
Group Delay	D/dt	At 3.58MHz (Notes 13, 14)		0		ns
Horizontal Tilt		(Notes 13, 14, 15)		0.10		%
Vertical Tilt		(Notes 13, 14, 15)		1.16		%

AC ELECTRICAL CHARACTERISTICS—MAX9546 Driving MAX9547

($V_{CC} = +8.5V$, $R_L = 220\Omega$ across OUT+ and OUT-, $R_L = 75\Omega$ (MAX9547), $Z_{ZT} = 75\Omega$, $T_A = -40^\circ C$ to $+85^\circ C$. Typical values are at $T_A = +25^\circ C$, unless otherwise noted.) (Note 3)

PARAMETER	SYMBOL	CONDITIONS	MIN	TYP	MAX	UNITS
Differential Gain	DG			3.8		%
Differential Phase	DP			0.6		degrees
Signal-to-Noise Ratio	SNR	5MHz lowpass, 100kHz highpass, $V_{IN} = 1V_{P-P}$		80		dB
2T Pulse-to-Bar Rating		2T = 250ns, bar time is 18µs, the beginning 3.5% and the ending 3.5% of the bar time is ignored		0.2		%
2T Pulse Response		2T = 250ns		0.25		%
Group Delay	D/dt	At 3.58MHz		10		ns
Horizontal Tilt		(Note 15)		0.12		%
Vertical Tilt		(Note 15)		0.26		%

Note 3: All devices are 100% production tested at $T_A = +25^\circ C$. All temperature limits are guaranteed by design.

Note 4: Defined as differential output to single-ended input.

Note 5: Input is AC-coupled.

Note 6: The RC time constant (3Hz) formed by the source resistance (R_S) and coupling capacitor (C_{IN}) is usually used for lead compensation of the active clamp. The source resistance is 400Ω max. The clamp should remain stable in this condition.

Note 7: Differential mode is measured as $(OUT+ - OUT-)$. Common mode is measured as $\frac{OUT+ + OUT-}{2}$

Note 8: A fault is when the outputs both sink and source current and the amount of extra current sink or source is greater than 3mA.

Note 9: Common-mode balance is measured as $20\log\left(\frac{OUT+ - OUT-}{\frac{OUT+ + OUT-}{2}}\right)$.

Note 10: These results were measured with a MAX4144 receiver, other receivers may affect results.

Note 11: Ground between MAX9546 and MAX9547 can be a ±2V difference.

Note 12: A loss-of-signal is when the input video signal of the MAX9547 does not change (cross 100mV level from sync tip) for 10 video lines.

Note 13: These results were measured with a MAX4447 transmitter and a MAX4012 buffer amplifier with a gain of 4. Using other devices may affect results.

Note 14: MAX9547 topology shown in Figure 3.

Note 15: Input capacitor for this test is 0.33µF.

Typical Operating Characteristics

($V_{CC} = +8.5V$, $R_L = 220\Omega$ between $OUT+$ and $OUT-$, $R_L = 75\Omega$ (MAX9547), $Z_{T} = 75\Omega$, $T_A = +25^\circ C$, unless otherwise noted.)

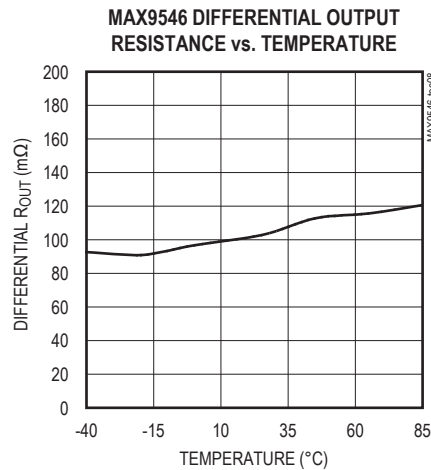
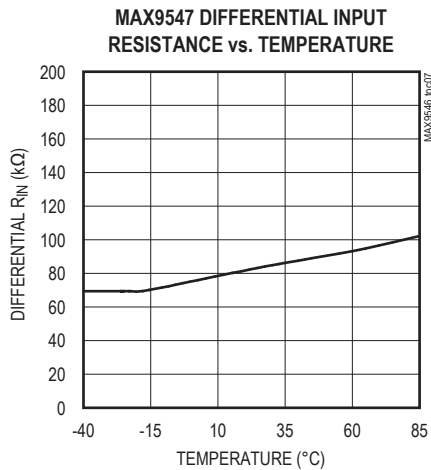
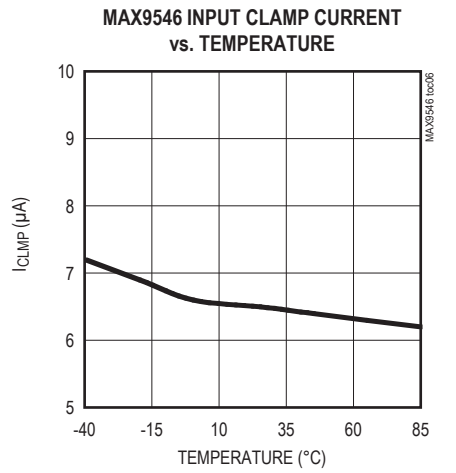
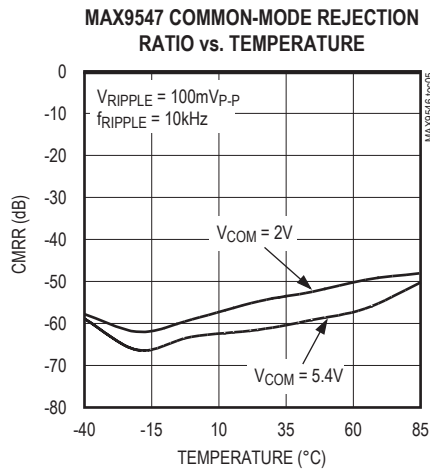
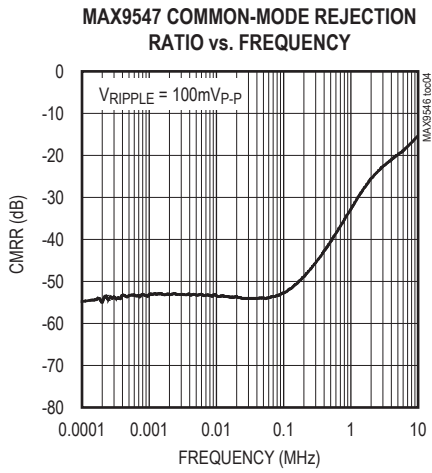
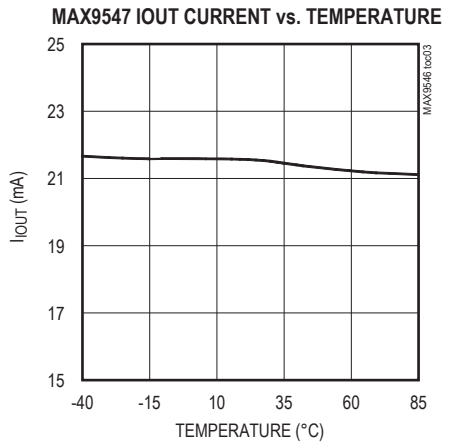
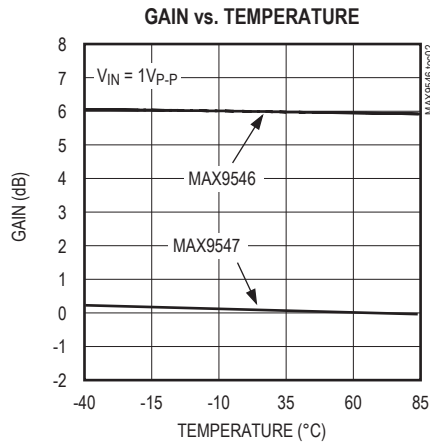
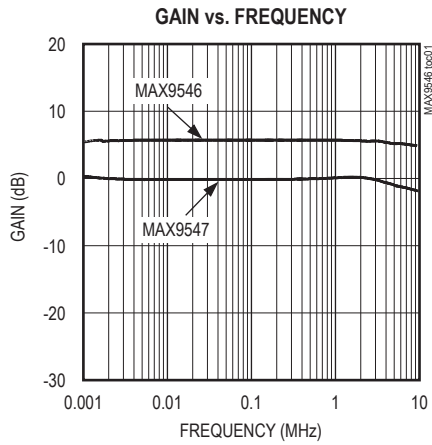

Typical Operating Characteristics (continued)

(VCC = +8.5V, RL = 220Ω between OUT+ and OUT-, RL = 75Ω (MAX9547), ZT = 75Ω, TA = +25°C, unless otherwise noted.)

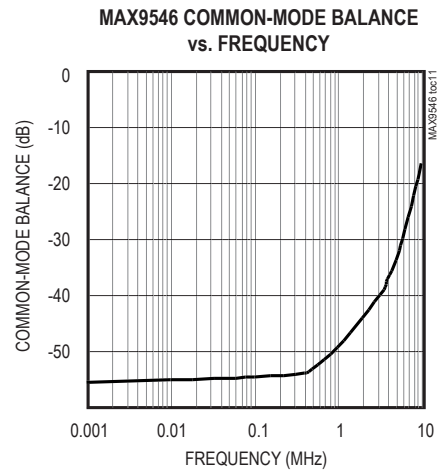
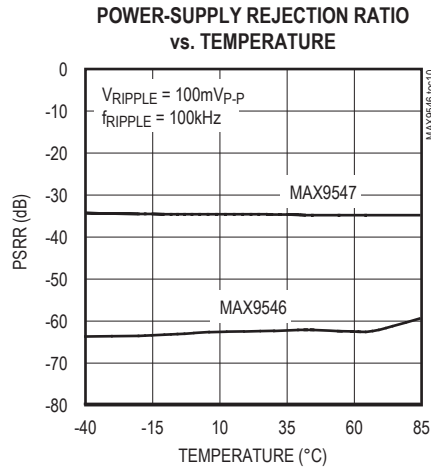
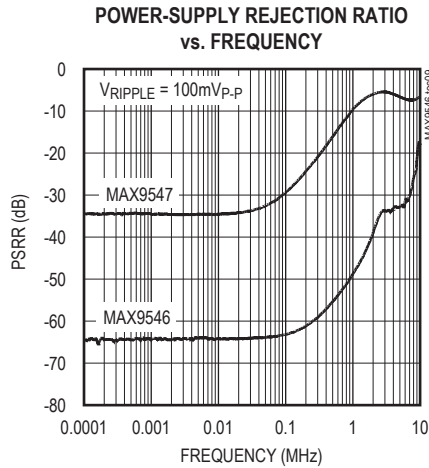

DIFFERENTIAL GAIN (MAX9546 DRIVING MAX9547)

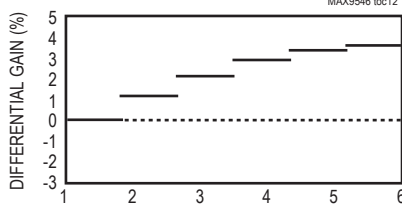

DIFFERENTIAL PHASE (MAX9546 DRIVING MAX9547)

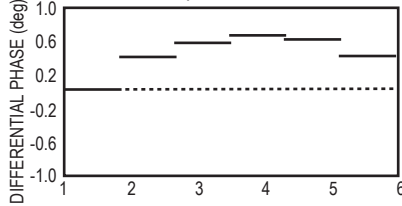

GROUP DELAY vs. FREQUENCY (MAX9546 DRIVING MAX9547)

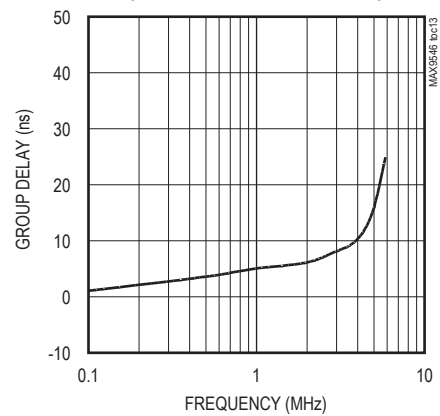

OUTPUT RESPONSE TO NTC-7 VIDEO TEST SIGNAL (MAX9546 DRIVING MAX9547)

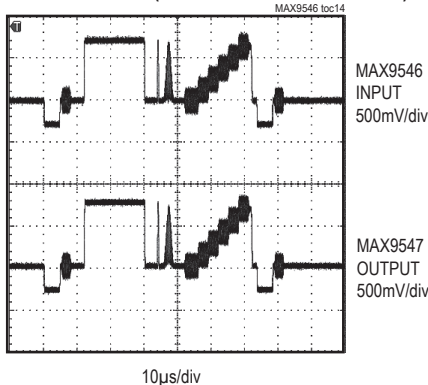

SIGNAL-TO-NOISE RATIO vs. FREQUENCY (MAX9546 DRIVING MAX9547)

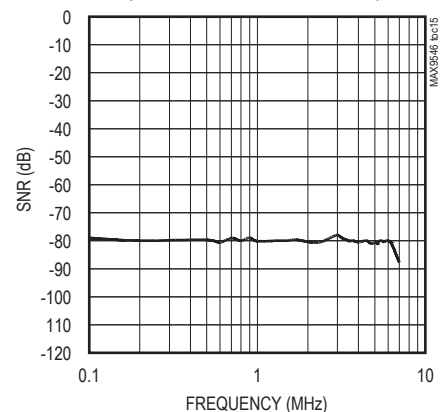

Pin Description (MAX9546)

PIN	NAME	FUNCTION
1, 8	V _{CC}	Power Supply. Connect together and bypass with a 0.1μF in parallel with a 4.7μF capacitor to GND.
2	IN	Video Input
3	$\overline{\text{FAULT}}$	Fault Indicator. Active-low, open-drain output. $\overline{\text{FAULT}}$ = low when fault is detected at the output. FAULT = high when no fault is detected at the output.
4, 5	GND	Ground
6	OUT-	Negative Differential Output
7	OUT+	Positive Differential Output
EP	EP	Exposed Paddle. Connect to GND.

Pin Description (MAX9547)

PIN	NAME	FUNCTION
1	IN+	Positive Differential Input
2	ZT+	Positive Transconductance Terminal
3	ZT-	Negative Transconductance Terminal
4	IN-	Negative Differential Input
5	GND	Ground
6	$\overline{\text{LOS}}$	Loss-of-Signal Indicator. Active-low, open-drain output. $\overline{\text{LOS}}$ = low when no signal is detected at the input. LOS = high when signal is present at the input.
7	IOUT	Current Output
8	V _{CC}	Power Supply. Bypass with a 0.1μF capacitor in parallel with a 4.7μF capacitor to GND.
EP	EP	Exposed Paddle. Connect to GND.

Detailed Description

The MAX9546/MAX9547 differential interface chipset converts single-ended voltages to differential voltages for transport and then converts back to single-ended voltages. The chipset is optimized for transporting CVBS/FBAS analog video signals (PAL or NTSC) through hostile environments. The MAX9546 driver includes a fault output ($\overline{\text{FAULT}}$) that indicates shorted transmission cables. The MAX9547 receiver loss-of-signal output ($\overline{\text{LOS}}$) indicates an absence of input signal.

The MAX9546/MAX9547 operate from a 7.5V to 10V single supply. The differential interface is immune to short-circuit conditions to supply (V_{CC}), or ground. These devices include ±15kV ESD (Human Body Model) protection.

MAX9546

Driver

The MAX9546 driver converts a single-ended video input into a differential output for transport across a twisted pair of wires. The input is AC-coupled and the video signal sync tip is clamped at 3.46V to set the voltage of the input. The output common-mode voltage is optimized to reject ground differences between the MAX9546 and MAX9547 up to ±2V. The differential gain is internally set to 2V/V to drive a back-terminated output to unity gain. The maximum input resistance should not exceed 400Ω to ensure device stability.

Common-Mode Balance

A driver is typically specified as having a property called common-mode balance (CMB), longitudinal balance, or simply line imbalance. Although balance is associated with the source, it assumes a perfectly balanced, correctly terminated, differential load. Common-mode balance is a measure of the ratio between the differential to the common-mode output in decibels as shown below.

$$\text{CMB} = 20\text{Log} \left(\frac{(\text{OUT}+) - (\text{OUT}-)}{(\text{OUT}+) + (\text{OUT}-)} \right)$$

Common-mode balance is dominated by the gain-bandwidth product at high frequencies and the output resistance at low frequencies; therefore, it is important to specify CMB over a frequency range. The receiver-side balance is determined by the common-mode rejection ratio (CMRR). The CMRR is usually quite large compared to the CMB; therefore, the CMB is the limiting factor.

Fault Protection and Detection

The MAX9546 fault protection insures the driver outputs survive a short to any voltage from -2V to +16V and are ESD-protected to $\pm 15\text{kV}$ HBM. Faults are indicated by an open-drain fault output ($\overline{\text{FAULT}}$) being asserted low and requires a pullup resistor from $\overline{\text{FAULT}}$ to V_{CC} .

MAX9547

Receiver

The MAX9547 receiver is a differential-to-single-ended converter that removes any common-mode input. The unique architecture allows the signal gain to be set by a ratio of two impedances: the user-selected transconductance element or network (Z_{ZT}), and an output load resistance, R_L . The gain is set by a fixed internal current gain (K) and the ratio of Z_{ZT} and R_L . The ZT terminals can be bridged with a complex impedance to provide lead-lag compensation.

The output is essentially a voltage-controlled current source as shown in Figure 1. The MAX9547 output is a current proportional to the differential input voltage, and inversely proportional to the impedance of the user-selected transconductance network, Z_{ZT} . The current output provides inherent short-circuit protection for the output terminal. A differential input voltage applied to the input terminals causes current to flow in the transconductance element (Z_{ZT}), which is equal to V_{IN}/Z_{ZT} . This current in the transconductance element is multiplied by the preset current gain (K) and appears on the output terminal as a current equal to $(K) \times (V_{IN}/Z_{ZT})$. This current flows through the load impedance to produce an output voltage according to the following equation:

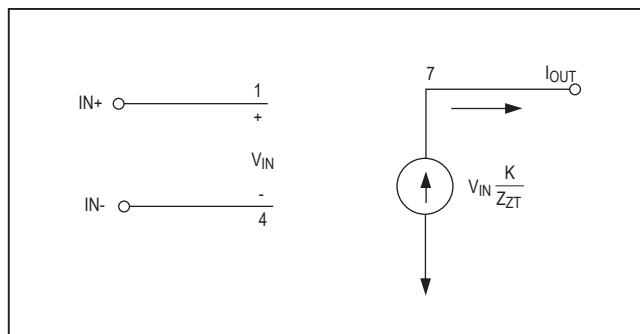

Figure 1. Operational Mode

$$V_{OUT} = K \left(\frac{V_{IN}}{Z_{ZT}} \right) R_L$$

where K = current-gain ratio ($K = 1$ for MAX9547), R_L = output load impedance, Z_{ZT} = transconductance element impedance, V_{IN} = differential input voltage.

Loss-of-Signal

The receiver includes an $\overline{\text{LOS}}$ output to indicate a signal by detecting the presence of H-Sync. This allows the MAX9547 to be used with monochrome or color video. $\overline{\text{LOS}}$ is an open-drain output and requires a pullup resistor from $\overline{\text{LOS}}$ to V_{CC} .

Setting the Circuit Gain

The MAX9547 produces an output current by multiplying the differential input voltage, V_{IN} , by the transconductance ratio, $K (R_L / Z_{ZT})$, where $K = 1$. The voltage gain (A_V) is set by the impedance of the transconductance network (Z_{ZT}) and the output load impedance (R_L) according to the following formula:

$$A_V = K \left(\frac{R_L}{Z_{ZT}} \right)$$

The factor Z_{ZT} is the impedance of the user-selected, two-terminal transconductance element or network, connected across the terminals labeled ZT+ and ZT-. The network Z_{ZT} is selected, along with the output impedance R_L , to provide the desired circuit gain and frequency shaping.

To maintain linearity, the transconductance network should also be selected so that current flowing through it, equal to V_{IN} / Z_{ZT} , does not exceed 18mA under worst-case conditions of maximum input voltage and minimum transconductance element impedance (Z_{ZT}). Output current should not exceed $\pm 8.8\text{mA}$ except under fault conditions.

Applications Information

Differential Interface

The impedances of the differential interface are made up of the two source resistors on the driver (MAX9546) shown as R_S and the load resistors on the receiver (MAX9547) shown as R_T in the *Typical Application Circuit*. These resistors are chosen so their sum matches the characteristic impedance (Z_0) of the differential transmission line. For example, a Category 5 cable has a characteristic impedance of 110Ω , so the sum of the two R_S or R_T resistors must be 110Ω to correctly drive the line. To balance the signals they must be equal, so R_S and R_T are 55Ω each.

Using Other Transmitters and Receivers

The MAX9546/MAX9547 are used with other transmitters and receivers; either other MAXIM devices or other

brands entirely. The overall performance of the MAX9546/MAX9547 is dependent on the choice of the receiver or transmitter, respectively.

Figure 2 illustrates one possible topology for the MAX9546 when using other devices with different offset requirements. Figures 3 and 4 illustrate two possible topologies for the MAX9547 when using other devices with unknown or different offset requirements. The circuit shown in Figure 3 has a smaller PCB footprint at the expense of requiring higher DC offset currents from the source device. Figure 4 requires no DC offset currents although it has a larger PCB footprint.

When using the MAX9546 with AC-coupling capacitors, the $\overline{\text{FAULT}}$ signal will continue to function but only with respect to a DC short condition. The $\overline{\text{LOS}}$ signal from the MAX9547 is unaffected by coupling capacitors.

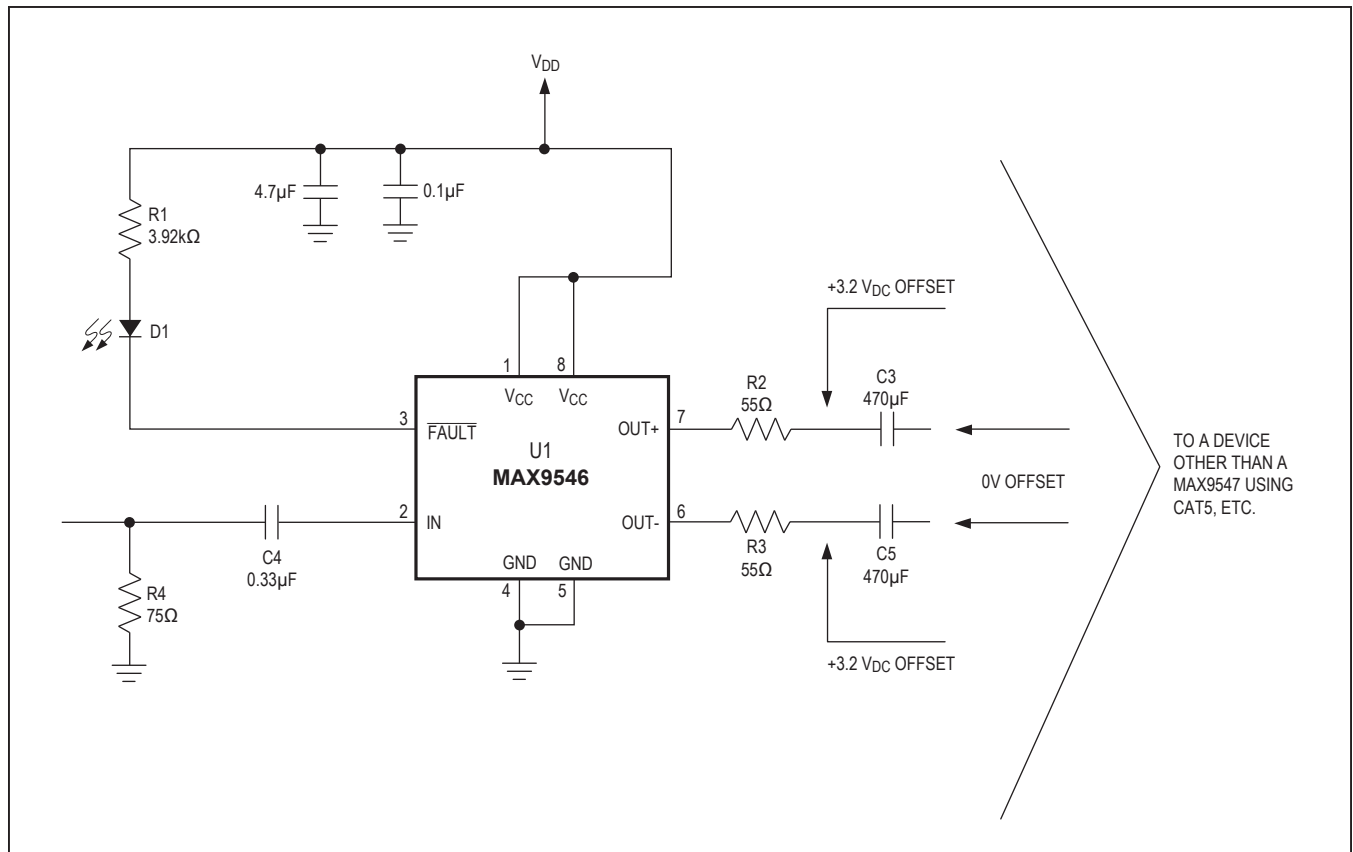

Figure 2. Suggested MAX9546 Configuration for Use with Other Devices

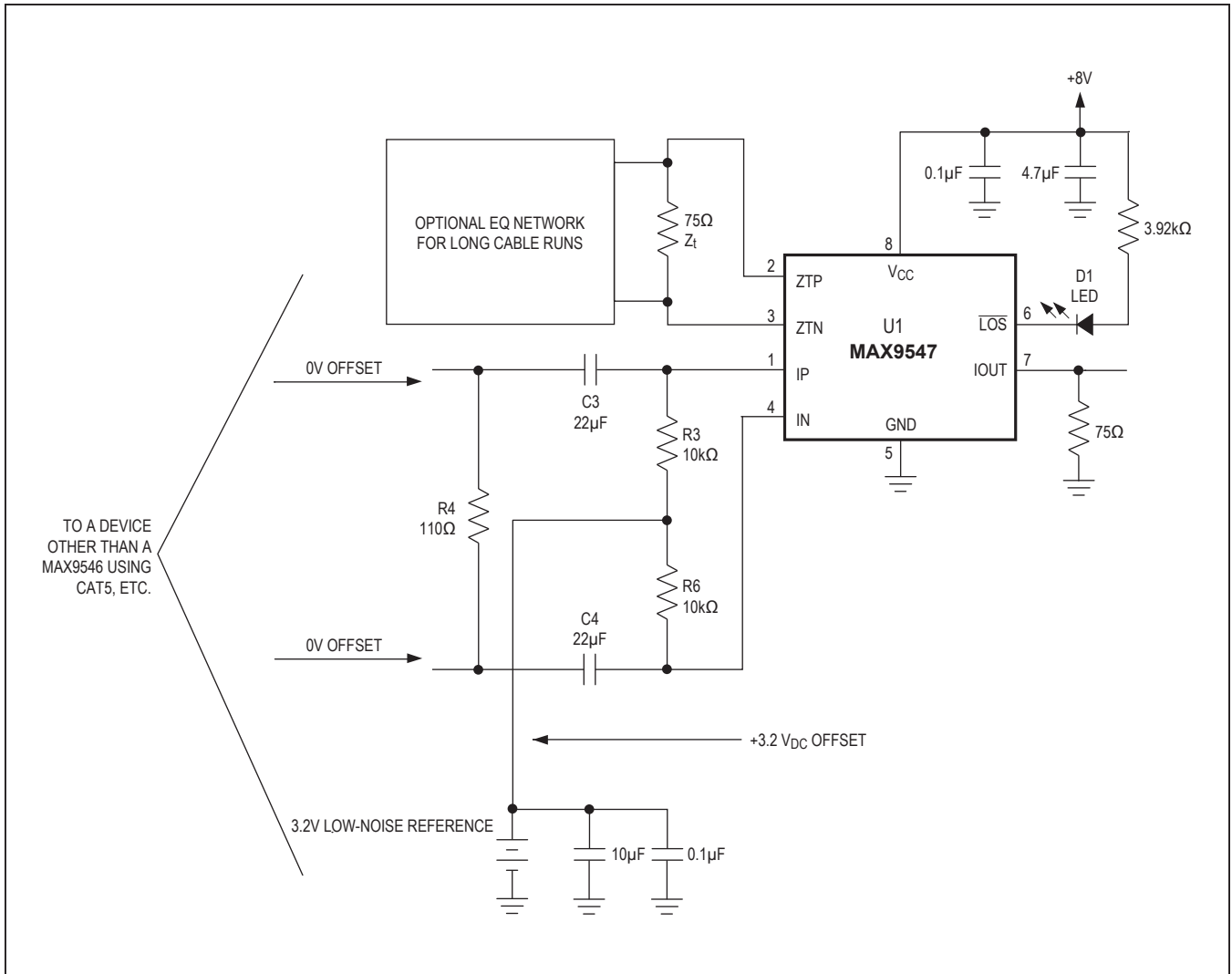

Figure 3. Suggested MAX9547 Configuration When Using Other Devices

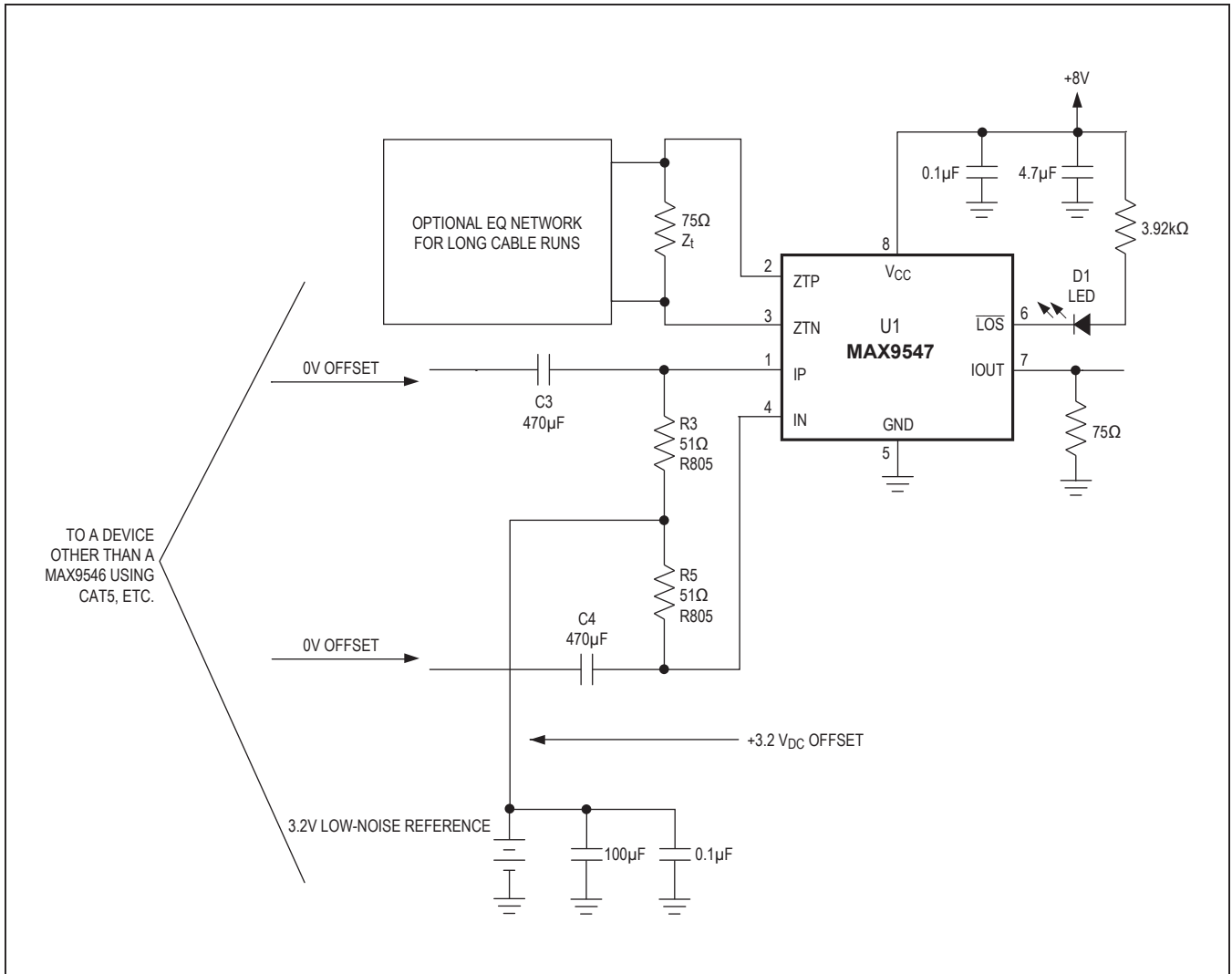

Figure 4. Alternate MAX9547 Configuration for Use with Other Devices

±15kV ESD Protection

As with all Maxim devices, ESD-protection structures are incorporated on all pins to protect against electrostatic discharges encountered during handling and assembly. The driver outputs and receiver inputs have extra protection against static electricity. Maxim’s engineers developed state-of-the-art structures to protect these pins against ESD of ±15kV without damage. The ESD structures withstand high ESD in all states: normal operation and powered down. After an ESD event, the MAX9546/MAX9547 keep working without latchup. ESD protection can be tested in various ways; the driver outputs and receiver inputs of this product family are characterized for protection to ±15kV using the Human Body Model. Other ESD test methodologies include IEC 1000-4-2 Contact

Discharge and IEC 1000-4-2 Air-Gap Discharge (formerly IEC 801-2).

ESD Test Conditions

ESD performance depends on a variety of conditions. Contact Maxim for a reliability report that documents test setup, test methodology, and test results.

Human Body Model

Figure 5 shows the Human Body Model, and Figure 6 shows the current waveform it generates when discharged into a low impedance. This model consists of a 100pF capacitor charged to the ESD voltage of interest, which is then discharged into the test device through a 1.5kΩ resistor.

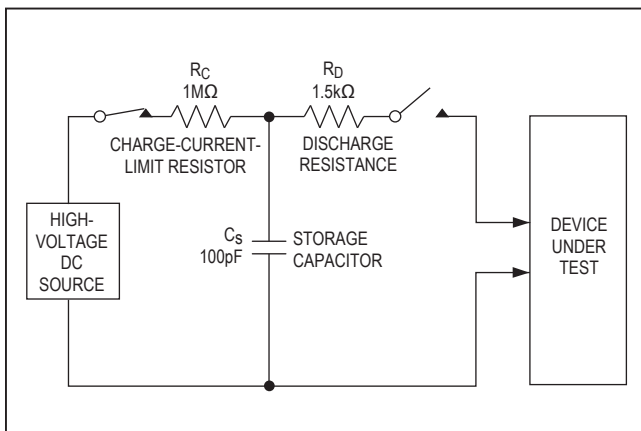

Figure 5. Human Body ESD Test Model

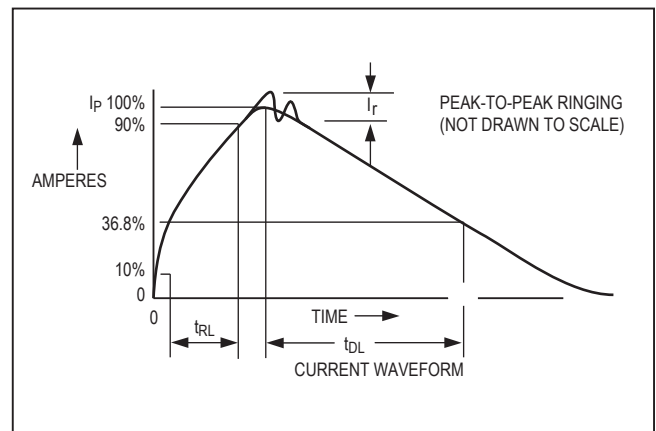

Figure 6. Human Body Current Waveform

IEC 1000-4-2

The IEC 1000-4-2 standard covers ESD testing and performance of finished equipment; it does not specifically refer to integrated circuits (Figure 7).

The major difference between tests done using the Human Body Model and IEC 1000-4-2 is higher peak current in IEC 1000-4-2, because series resistance is

lower in the IEC 1000-4-2 model. Hence, the ESD withstand voltage measured to IEC 1000-4-2 is generally lower than that measured using the Human Body Model. Figure 8 shows the current waveform for the $\pm 8\text{kV}$ IEC 1000-4-2 ESD Contact-Discharge test. The Air-Gap test involves approaching the device with a charged probe. The Contact-Discharge method connects the probe to the device before the probe is energized.

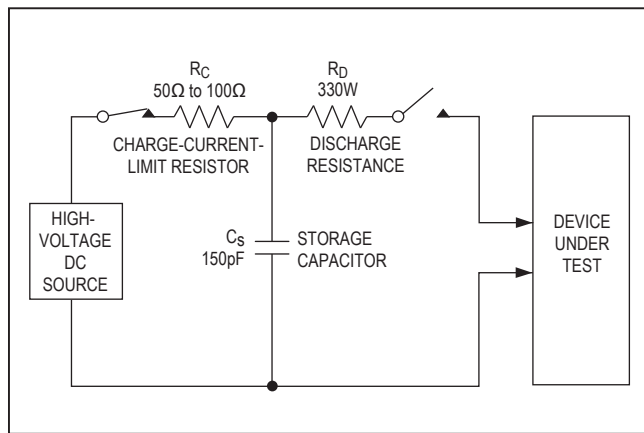

Figure 7. IEC 1000-4-2 ESD Test Model

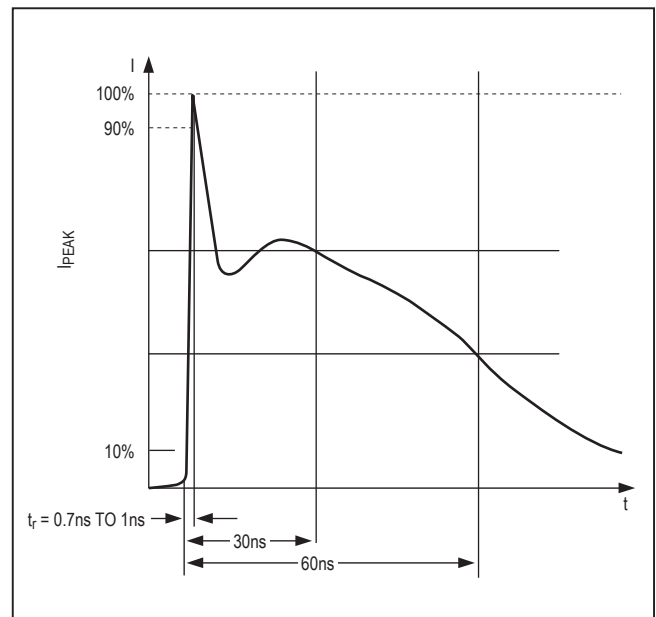
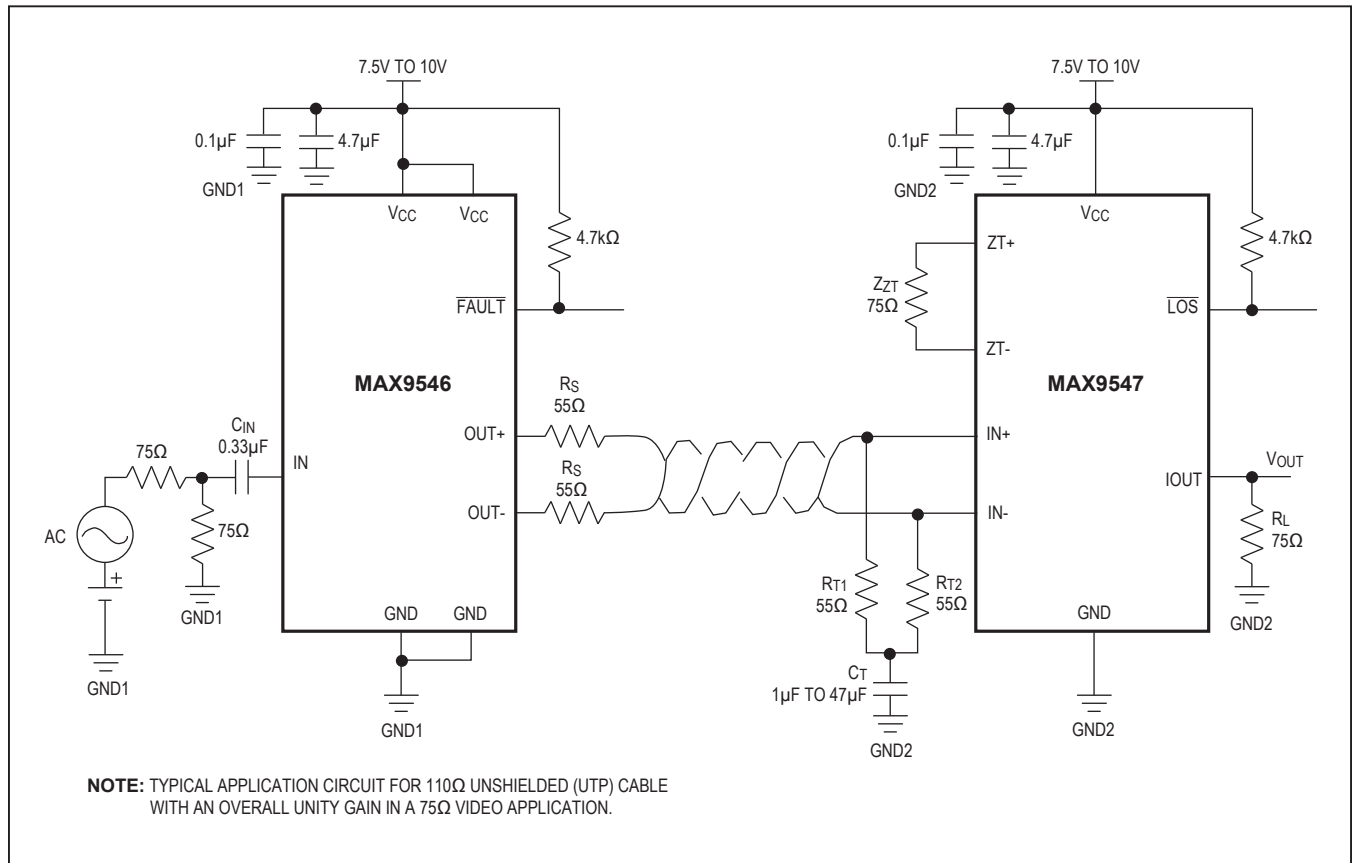
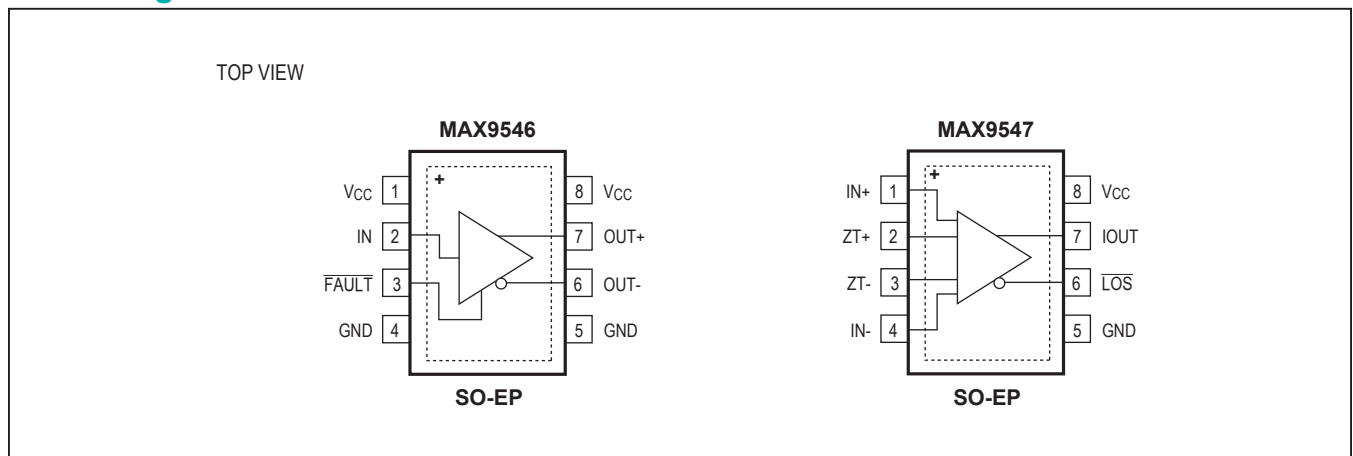

Figure 8. IEC 1000-4-2 ESD Generator Current Waveform

Typical Application Circuit



Pin Configurations



Chip Information

PROCESS: BiCMOS

Package Information

For the latest package outline information and land patterns (footprints), go to www.maximintegrated.com/packages. Note that a "+", "#", or "-" in the package code indicates RoHS status only. Package drawings may show a different suffix character, but the drawing pertains to the package regardless of RoHS status.

PACKAGE TYPE	PACKAGE CODE	OUTLINE NO.	LAND PATTERN NO.
8 SO-EP	S8E+14	21-0111	90-0151

TOP VIEW

BOTTOM VIEW

DIM	INCHES		MILLIMETERS	
	MIN	MAX	MIN	MAX
A	0.056	0.066	1.43	1.68
A1	0.000	0.004	0.00	0.10
b	0.014	0.019	0.35	0.49
C	0.007	0.010	0.19	0.25
D	0.189	0.196	4.80	4.98
e	0.050	BSC	1.27	BSC
E	0.150	0.157	3.81	3.99
H	0.230	0.244	5.81	6.20
h	0.010	0.016	0.25	0.41
L	0.016	0.035	0.41	0.89
α	0°	8°	0°	8°
N	8			

PKG.	X (mm)		Y (mm)	
	MIN	MAX	MIN	MAX
S8E-12	1.98	2.29	1.98	2.29
S8E-14	2.79	3.10	2.11	2.41

NOTES:

1. D&E DO NOT INCLUDE MOLD FLASH.
2. MOLD FLASH OR PROTRUSIONS NOT TO EXCEED .15mm (.006")
3. CONTROLLING DIMENSION: MILLIMETER
4. MEETS JEDEC MS-012 EXCEPT DIMENSION A1.
5. DIMENSIONS X AND Y DEFINE EXPOSED PAD METAL AREA.
6. MARKING SHOWN IS FOR PKG. ORIENTATION ONLY.
7. ALL DIMENSIONS APPLY TO BOTH LEADED (-) AND PbFREE (+) PKG. CODES.

—DRAWING NOT TO SCALE—

TITLE: PACKAGE OUTLINE, 8L SOIC, .150" EXPOSED PAD			
APPROVAL	DOCUMENT CONTROL NO. 21-0111	REV. E	1/1

Revision History

REVISION NUMBER	REVISION DATE	DESCRIPTION	PAGES CHANGED
4	9/14	Removed automotive references from <i>Applications</i> and <i>Detailed Description</i> sections	1, 8

For pricing, delivery, and ordering information, please contact Maxim Direct at 1-888-629-4642, or visit Maxim Integrated's website at www.maximintegrated.com.

Maxim Integrated cannot assume responsibility for use of any circuitry other than circuitry entirely embodied in a Maxim Integrated product. No circuit patent licenses are implied. Maxim Integrated reserves the right to change the circuitry and specifications without notice at any time. The parametric values (min and max limits) shown in the Electrical Characteristics table are guaranteed. Other parametric values quoted in this data sheet are provided for guidance.

Looking for pricing, stock, or lifecycle information?

Click below to explore more details on WIN SOURCE:

 [View MAX9547ESA+T on WIN SOURCE](#)

 [Maxim Integrated](#) Information

Optimize Your Supply Chain with WIN SOURCE Solutions

-  Global Sourcing Solution
-  Obsolete Management
-  Cost Control Management
-  Shortage Management
-  Alternative Solution
-  Excess Inventory Management