



**THE DATASHEET OF  
MAX9324EUP+**





# One-to-Five LVPECL/LVCMOS Output Clock and Data Driver

MAX9324

## General Description

The MAX9324 low-skew, low-jitter, clock and data driver distributes a differential LVPECL input to four differential LVPECL outputs and one single-ended LVCMOS output. All outputs default to logic low when the differential inputs equal GND or are left open. The MAX9324 operates from 3.0V to 3.6V, making it ideal for 3.3V systems, and consumes only 25mA (max) of supply current.

The MAX9324 features low 150ps (max) part-to-part skew, low 15ps output-to-output skew, and low 1.7ps RMS jitter, making the device ideal for clock and data distribution across a backplane or board. CLK\_EN and SEOUT\_Z control the status of the various outputs. Asserting CLK\_EN low configures the differential (Q<sub>-</sub>, Q<sub>-</sub>) outputs to a differential low condition and SEOUT to a single-ended logic-low state. CLK\_EN operation is synchronous with the CLK<sub>-</sub> inputs. A logic high on SEOUT\_Z places SEOUT in a high-impedance state. SEOUT\_Z is asynchronous with the CLK (CLK) inputs.

The MAX9324 is available in space-saving 20-pin TSSOP and ultra-small 20-pin 4mm x 4mm thin QFN packages and operates over the extended (-40°C to +85°C) temperature range.

## Applications

- Precision Clock Distribution
- Low-Jitter Data Repeater
- Data and Clock Driver and Buffer
- Central-Office Backplane Clock Distribution
- DSLAM Backplane
- Base Station
- ATE

## Features

- ◆ 15ps Differential Output-to-Output Skew
- ◆ 1.7ps<sub>RMS</sub> Added Random Jitter
- ◆ 150ps (max) Part-to-Part Skew
- ◆ 450ps Propagation Delay
- ◆ Synchronous Output Enable/Disable
- ◆ Single-Ended Monitor Output
- ◆ Outputs Assert Low when CLK, CLK are Open or at GND
- ◆ 3.0V to 3.6V Supply Voltage Range
- ◆ -40°C to +85°C Operating Temperature Range

## Ordering Information

PART	TEMP RANGE	PIN-PACKAGE
MAX9324EUP	-40°C to +85°C	20 TSSOP
MAX9324ETP*	-40°C to +85°C	20 Thin QFN-EP**

\*Future product—Contact factory for availability.

\*\*EP = Exposed paddle.

Functional Diagram and Typical Operating Circuit appear at end of data sheet.

## Pin Configurations

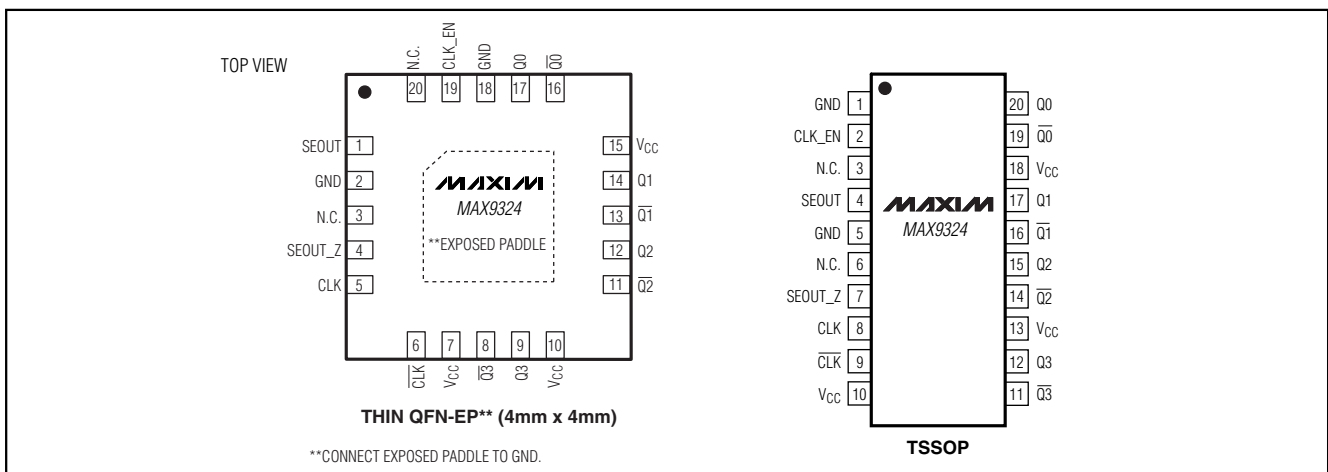

# One-to-Five LVPECL/LVCMOS Output Clock and Data Driver

## ABSOLUTE MAXIMUM RATINGS

V <sub>CC</sub> to GND	-0.3V to +4.0V
Q <sub>-</sub> , Q <sub>+</sub> , CLK, CLK, SEOUT_Z, CLK_EN, SEOUT to GND	-0.3V to (V <sub>CC</sub> + 0.3V)
CLK to CLK	±3V
SEOUT Short to GND	Continuous
Continuous Output Current (Q <sub>-</sub> , Q <sub>+</sub> )	50mA
Surge Output Current (Q <sub>-</sub> , Q <sub>+</sub> )	100mA
Continuous Power Dissipation (T <sub>A</sub> = +70°C)	
20-Pin TSSOP (derate 11mW/°C)	879.1mW
20-Pin 4mm × 4mm Thin QFN (derate 16.9mW/°C)	1349.1mW

Junction-to-Ambient Thermal Resistance in Still Air	
20-Pin TSSOP	+91°C/W
20-Pin 4mm × 4mm Thin QFN	+59.3°C/W
Junction-to-Case Thermal Resistance	
20-Pin TSSOP	+20°C/W
20-Pin 4mm × 4mm Thin QFN	+2°C/W
Operating Temperature Range	-40°C to +85°C
Junction Temperature	+150°C
Storage Temperature Range	-65°C to +150°C
Soldering Temperature (10s)	+300°C

Stresses beyond those listed under "Absolute Maximum Ratings" may cause permanent damage to the device. These are stress ratings only, and functional operation of the device at these or any other conditions beyond those indicated in the operational sections of the specifications is not implied. Exposure to absolute maximum rating conditions for extended periods may affect device reliability.

## DC ELECTRICAL CHARACTERISTICS

(V<sub>CC</sub> = 3.0V to 3.6V, differential outputs terminated with 50Ω ±1% to (V<sub>CC</sub> - 2V), SEOUT\_Z = GND, CLK\_EN = V<sub>CC</sub>, T<sub>A</sub> = -40°C to +85°C, unless otherwise noted. Typical values are at V<sub>CC</sub> = 3.3V, T<sub>A</sub> = +25°C.) (Notes 1, 2, and 3)

PARAMETER	SYMBOL	CONDITIONS	MIN	TYP	MAX	UNITS
<b>SINGLE-ENDED INPUTS (CLK_EN, SEOUT_Z)</b>						
Input High Voltage	V <sub>IH</sub>		2		V <sub>CC</sub>	V
Input Low Voltage	V <sub>IL</sub>		0		0.8	V
Input High Current	I <sub>IH</sub>	CLK_EN = V <sub>CC</sub>	-5		+5	μA
		SEOUT_Z = V <sub>CC</sub>			150	
Input Low Current	I <sub>IL</sub>	CLK_EN = GND	-150			μA
		SEOUT_Z = GND	-5		+5	
<b>DIFFERENTIAL INPUT (CLK, CLK)</b>						
Differential Input High Voltage	V <sub>IHD</sub>	Figure 1	1.5		V <sub>CC</sub>	V
Differential Input Low Voltage	V <sub>ILD</sub>	Figure 1	0		V <sub>CC</sub> - 0.15	V
Differential Input Voltage	V <sub>IHD</sub> - V <sub>ILD</sub>		0.15		1.5	V
Input Current	I <sub>CLK</sub>	V <sub>IHD</sub> , V <sub>ILD</sub>	-5		+150	μA
<b>DIFFERENTIAL OUTPUTS (Q<sub>-</sub>, Q<sub>+</sub>)</b>						
Single-Ended Output High	V <sub>OH</sub>	Figure 1	V <sub>CC</sub> - 1.4		V <sub>CC</sub> - 1.0	V
Single-Ended Output Low	V <sub>OL</sub>	Figure 1	V <sub>CC</sub> - 2.0		V <sub>CC</sub> - 1.7	V
Differential Output Voltage	V <sub>OH</sub> - V <sub>OL</sub>	Figure 1	0.6		0.85	V
<b>SINGLE-ENDED OUTPUT (SEOUT)</b>						
Output High Voltage	V <sub>OH</sub>	I <sub>OH</sub> = -4mA	2.4			V
Output Low Voltage	V <sub>OL</sub>	I <sub>OL</sub> = 4mA			0.4	V
Output High-Impedance Current	I <sub>OZ</sub>	SEOUT_Z = V <sub>CC</sub> , SEOUT = V <sub>CC</sub> or GND	-10		+10	μA
Output Short-Circuit Current	I <sub>OS</sub>	V <sub>CLK</sub> = V <sub>CC</sub> , SEOUT = GND			75	mA
<b>SUPPLY</b>						
Supply Current	I <sub>CC</sub>	(Note 4)			25	mA

# One-to-Five LVPECL/LVCMOS Output Clock and Data Driver

## AC ELECTRICAL CHARACTERISTICS

( $V_{CC} = 3.0V$  to  $3.6V$ , differential outputs terminated with  $50\Omega \pm 1\%$  to  $(V_{CC} - 2V)$ ,  $f_{CLK} \leq 266MHz$ , input duty cycle = 50%, input transition time = 125ps (20% to 80%),  $V_{IHD} = 1.5V$  to  $V_{CC}$ ,  $V_{ILD} = GND$  to  $(V_{CC} - 0.15V)$ ,  $V_{IHD} - V_{ILD} = 0.15V$  to  $1.5V$ ,  $CLK\_EN = V_{CC}$ ,  $SEOUT\_Z = GND$ ,  $T_A = -40^\circ C$  to  $+85^\circ C$ , unless otherwise noted. Typical values are at  $V_{CC} = 3.3V$ ,  $V_{IHD} = (V_{CC} - 1V)$ ,  $V_{ILD} = (V_{CC} - 1.5V)$ ,  $T_A = +25^\circ C$ .) (Note 5)

PARAMETER	SYMBOL	CONDITIONS	MIN	TYP	MAX	UNITS
Switching Frequency	$f_{MAX}$	$V_{OH} - V_{OL} \geq 0.6V$ , $SEOUT\_Z = V_{CC}$	650	800		MHz
		$SEOUT\_Z = GND$ , $SEOUT$	125	200		
Propagation Delay	$t_{PHL}$ , $t_{PLH}$	$CLK$ , $\overline{CLK}$ to $Q_-$ , $\overline{Q_-}$ , Figure 1 (Note 6)	100	450	600	ps
Output-to-Output Skew	$t_{SKOO}$	(Note 7)			30	ps
Part-to-Part Skew	$t_{SKPP}$	(Note 8)			150	ps
Output Rise Time	$t_R$	20% to 80%, Figure 1	100	217	300	ps
Output Fall Time	$t_F$	80% to 20%, Figure 1	100	207	300	ps
Output Duty Cycle	ODC		48	50	52	%
Added Random Jitter	$t_{RJ}$	$f_{CLK} = 650MHz$ (Note 9)		1.7	3	ps(RMS)
Added Deterministic Jitter	$t_{DJ}$	$2e^{23} - 1$ PRBS pattern, $f = 650Mbps$ (Note 9)		83	100	ps(P-P)
Added Jitter	$t_{AJ}$	$V_{CC} = 3.3V$ with 25mV superimposed sinusoidal noise at 100kHz (Note 9)		8.5	12	ps(P-P)
Single-Ended Output Rise Time	$t_R$	$C_L = 15pF$ , 20% to 80%, Figure 1		1.6	2	ns
Single-Ended Output Fall Time	$t_F$	$C_L = 15pF$ , 80% to 20%, Figure 1		1.6	2	ns
Single-Ended Output Duty Cycle	ODC	(Note 10)	40	52	60	%

**Note 1:** Measurements are made with the device in thermal equilibrium.

**Note 2:** Current into a pin is defined as positive. Current out of a pin is defined as negative.

**Note 3:** DC parameters are production tested at  $T_A = +25^\circ C$  and guaranteed by design over the full operating temperature range.

**Note 4:** All pins open except  $V_{CC}$  and  $GND$ .

**Note 5:** Guaranteed by design and characterization. Limits are set at  $\pm 6$  sigma.

**Note 6:** Measured from the differential input signal crosspoint to the differential output signal crosspoint.

**Note 7:** Measured between the differential outputs of the same part at the differential signal crosspoint for a same-edge transition.

**Note 8:** Measured between the differential outputs of different parts at the differential signal crosspoint under identical conditions for a same-edge transition.

**Note 9:** Jitter added to the input signal.

**Note 10:** Measured at 50% of  $V_{CC}$ .

# One-to-Five LVPECL/LVCMOS Output Clock and Data Driver

## Typical Operating Characteristics

( $V_{CC} = 3.3V$ , outputs terminated to ( $V_{CC} - 2V$ ) through  $50\Omega$ ,  $SEOUT\_Z = V_{CC}$ ,  $CLK\_EN = V_{CC}$ ,  $T_A = +25^\circ C$ .)

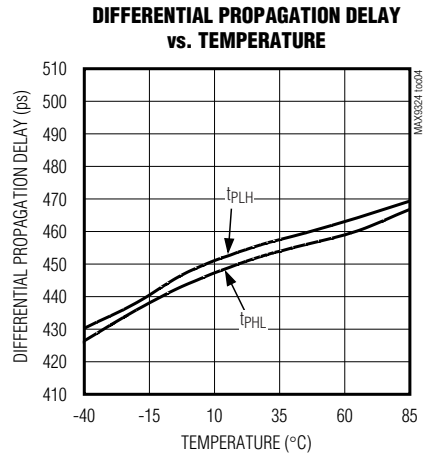
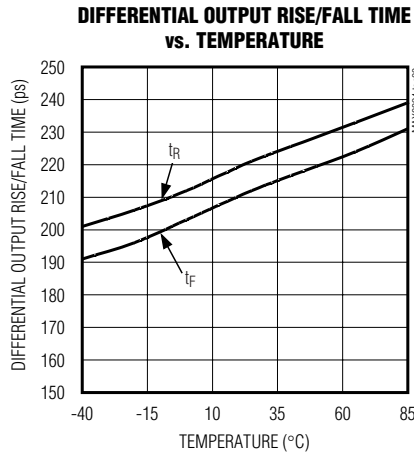
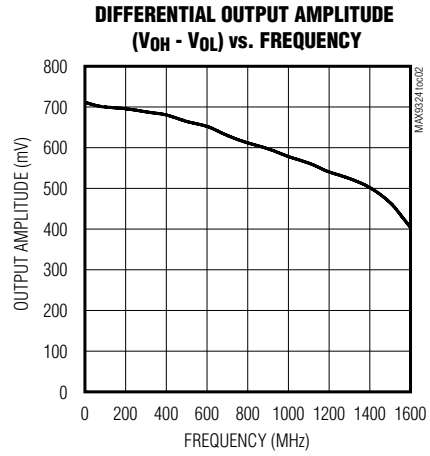
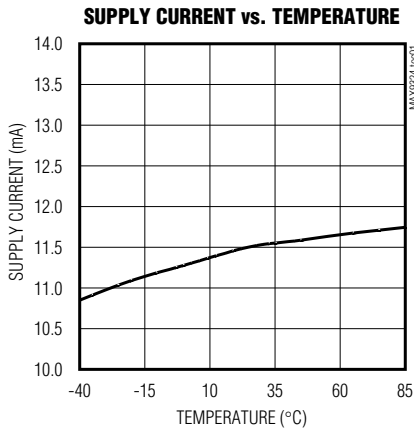

# One-to-Five LVPECL/LVCMOS Output Clock and Data Driver

## Pin Description

MAX9324

PIN		NAME	FUNCTION
TSSOP	QFN		
1, 5	2, 18	GND	Ground. Provide a low-impedance connection to the ground plane.
2	19	CLK_EN	Synchronous Output Enable. Connect CLK_EN to V <sub>CC</sub> or leave floating to enable the differential outputs. Connect CLK_EN to GND to disable the differential outputs. When disabled, Q <sub>-</sub> asserts low, $\overline{Q}$ <sub>-</sub> asserts high, and SEOUT asserts low. A 51k $\Omega$ pullup resistor to V <sub>CC</sub> allows CLK_EN to be left floating.
3, 6	3, 20	N.C.	No Connect. Not internally connected.
4	1	SEOUT	LVCMOS/LVTTL Clock Output. SEOUT reproduces CLK when SEOUT_Z = GND. SEOUT goes high impedance when SEOUT_Z = V <sub>CC</sub> . The maximum output frequency of SEOUT is 125MHz.
7	4	SEOUT_Z	Single-Ended Clock Output Enable/Disable. Connect SEOUT_Z to GND to enable the single-ended clock output. Connect SEOUT_Z to V <sub>CC</sub> to disable the single-ended clock output. A 51k $\Omega$ pulldown resistor to GND allows SEOUT_Z to be left floating.
8	5	CLK	Noninverting Differential LVPECL Input. An internal 51k $\Omega$ pulldown resistor to GND forces the outputs (Q <sub>-</sub> , $\overline{Q}$ <sub>-</sub> ) to differential low and logic low (SEOUT) when CLK and $\overline{CLK}$ are left open or at GND and the outputs are enabled.
9	6	$\overline{CLK}$	Inverting Differential LVPECL Input. An internal 51k $\Omega$ pulldown resistor to GND forces the outputs (Q <sub>-</sub> , $\overline{Q}$ <sub>-</sub> ) to differential low and logic low (SEOUT) when CLK and $\overline{CLK}$ are left open or at GND and the outputs are enabled.
10, 13, 18	7, 10, 15	V <sub>CC</sub>	Positive Supply Voltage. Bypass V <sub>CC</sub> to GND with three 0.01 $\mu$ F and one 0.1 $\mu$ F ceramic capacitors. Place the 0.01 $\mu$ F capacitors as close to each V <sub>CC</sub> input as possible (one per V <sub>CC</sub> input). Connect all V <sub>CC</sub> inputs together, and bypass to GND with a 0.1 $\mu$ F ceramic capacitor.
11	8	$\overline{Q3}$	Inverting Differential LVPECL Output. Terminate $\overline{Q3}$ to (V <sub>CC</sub> - 2V) with a 50 $\Omega$ $\pm$ 1% resistor.
12	9	Q3	Noninverting Differential LVPECL Output. Terminate Q3 to (V <sub>CC</sub> - 2V) with a 50 $\Omega$ $\pm$ 1% resistor.
14	11	$\overline{Q2}$	Inverting Differential LVPECL Output. Terminate $\overline{Q2}$ to (V <sub>CC</sub> - 2V) with a 50 $\Omega$ $\pm$ 1% resistor.
15	12	Q2	Noninverting Differential LVPECL Output. Terminate Q2 to (V <sub>CC</sub> - 2V) with a 50 $\Omega$ $\pm$ 1% resistor.
16	13	$\overline{Q1}$	Inverting Differential LVPECL Output. Terminate $\overline{Q1}$ to (V <sub>CC</sub> - 2V) with a 50 $\Omega$ $\pm$ 1% resistor.
17	14	Q1	Noninverting Differential LVPECL Output. Terminate Q1 to (V <sub>CC</sub> - 2V) with a 50 $\Omega$ $\pm$ 1% resistor.
19	16	$\overline{Q0}$	Inverting Differential LVPECL Output. Terminate $\overline{Q0}$ to (V <sub>CC</sub> - 2V) with a 50 $\Omega$ $\pm$ 1% resistor.
20	17	Q0	Noninverting Differential LVPECL Output. Terminate Q0 to (V <sub>CC</sub> - 2V) with a 50 $\Omega$ $\pm$ 1% resistor.

# One-to-Five LVPECL/LVCMOS Output Clock and Data Driver

## Detailed Description

The MAX9324 low-skew, low-jitter, clock and data driver distributes a differential LVPECL input signal to four differential LVPECL outputs and a single-ended LVC-MOS output. The differential output drivers operate at frequencies up to 800MHz. When SEOUT\_Z = GND, the single-ended LVCMOS output driver operates with frequencies as high as 200MHz. The MAX9324 operates from 3.0V to 3.6V, making the device ideal for 3.3V systems.

## Data Inputs

### Differential LVPECL Inputs

The MAX9324 accepts a differential LVPECL input. Each differential output duplicates the differential input

signal. Terminate CLK and  $\overline{\text{CLK}}$  through  $50\Omega$  to ( $V_{CC} - 2V$ ) to minimize input signal reflections. Internal  $51k\Omega$  pull-down resistors to GND ensure the outputs default to differential low ( $Q_-, \overline{Q}_-$ ) or logic low (SEOUT) when the CLK inputs are left open.

### CLK\_EN Input

CLK\_EN enables/disables the differential outputs of the MAX9324. Connect CLK\_EN to  $V_{CC}$  to enable the differential outputs. The ( $Q_-, \overline{Q}_-$ ) outputs are driven to a differential low condition when CLK\_EN = GND. Each differential output pair disables following successive rising and falling edges on CLK (falling and rising edges on CLK), after CLK\_EN connects to GND. Both a rising and falling edge on CLK are required to complete the enable/disable function (Figure 2).

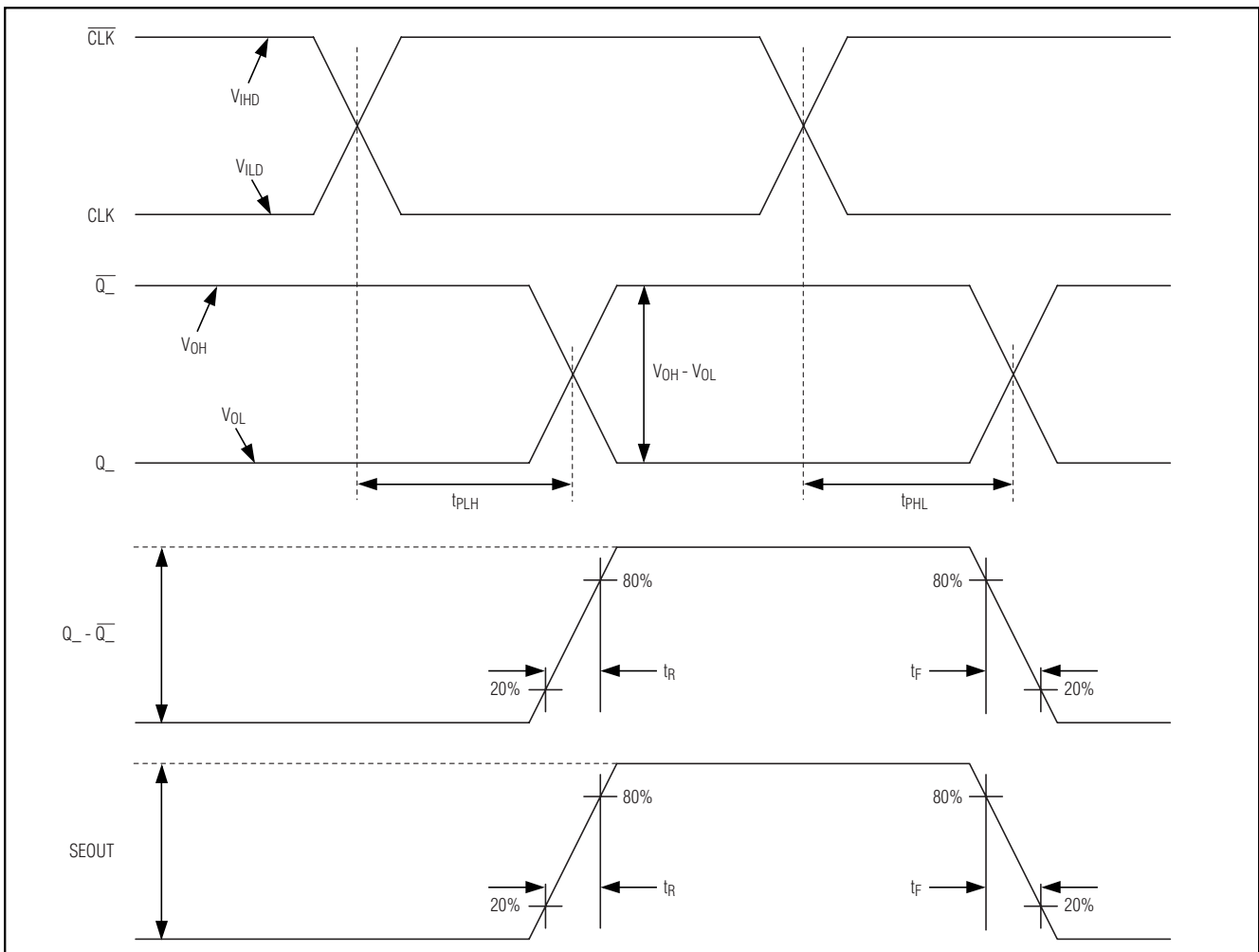

Figure 1. MAX9324 Clock Input-to-Output Delay and Rise/Fall Time

# One-to-Five LVPECL/LVCMOS Output Clock and Data Driver

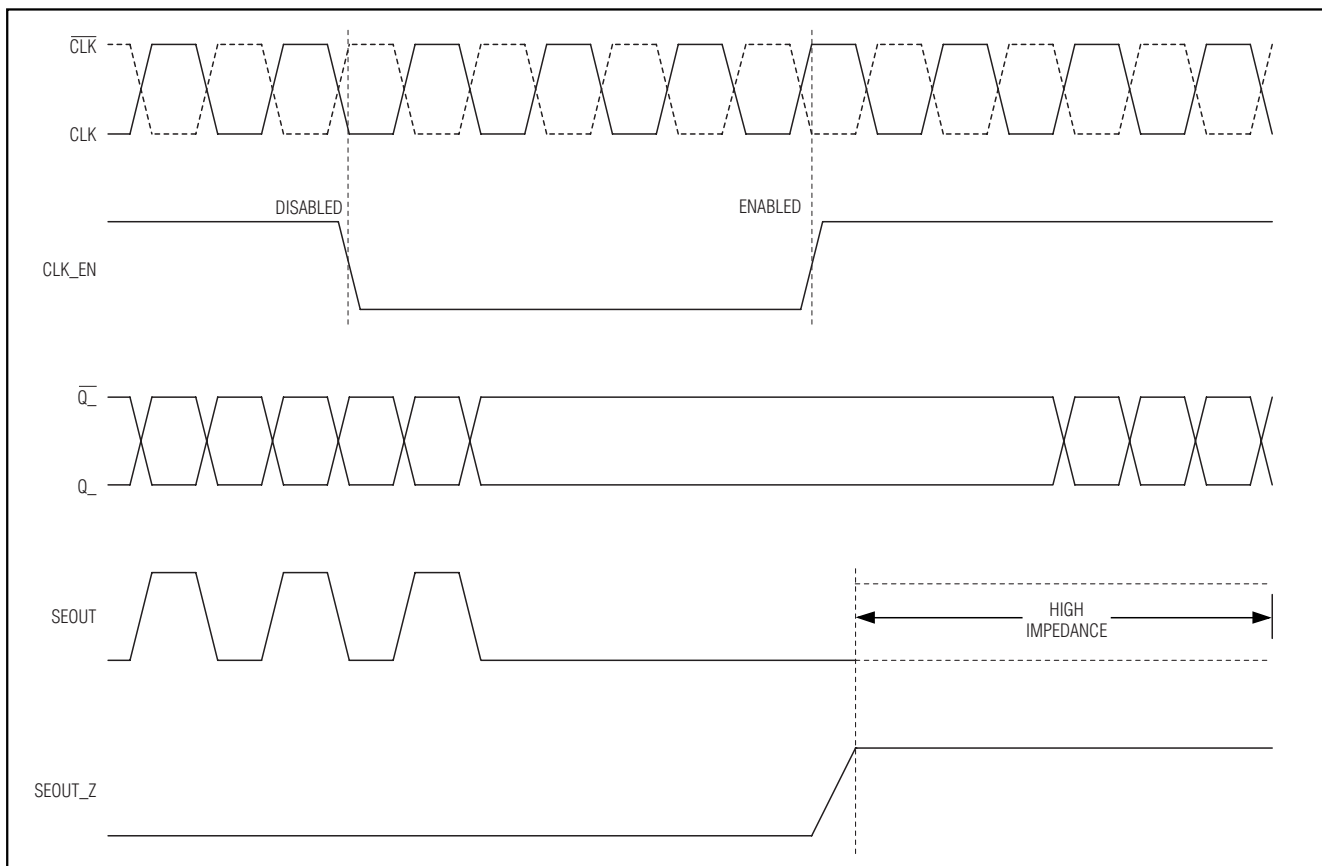

Figure 2. MAX9324 CLK\_EN Timing Diagram

### SEOUT\_Z

SEOUT\_Z enables/disables the single-ended LVCMOS output (Table 1). Connect SEOUT\_Z to GND to enable the single-ended output. Connect SEOUT\_Z to V<sub>CC</sub> to force the single-ended output to a high-impedance state. SEOUT provides a single-ended monitor for operating frequencies as high as 200MHz.

### Applications Information

#### Output Termination

Terminate both outputs of each differential pair through 50Ω to (V<sub>CC</sub> - 2V) or use an equivalent Thevenin termination. Use identical termination on each output for the lowest output-to-output skew. Terminate both outputs when deriving a single-ended signal from a differential output. For example, using Q0 as a single-ended output requires termination for both Q0 and Q<sub>0</sub>.

Table 1. Control Input Table

INPUTS		OUTPUTS		
CLK_EN	SEOUT_Z	Q0-Q3	Q <sub>0</sub> -Q <sub>3</sub>	SEOUT
0	0	Disabled, pulled to logic low	Disabled, pulled to logic high	Enabled, logic low
0	1	Disabled, pulled to logic low	Disabled, pulled to logic high	Disabled, high impedance
1	0	Enabled	Enabled	Enabled
1	1	Enabled	Enabled	Disabled, high impedance

# One-to-Five LVPECL/LVCMOS Output Clock and Data Driver

SEOUT provides a single-ended LVCMOS monitor output. SEOUT operates with a maximum output frequency of 200MHz.

Ensure that the output currents do not violate the current limits as specified in the *Absolute Maximum Ratings* table. Observe the device's total thermal limits under all operating conditions.

### Power-Supply Bypassing

Bypass  $V_{CC}$  to GND using three 0.01 $\mu$ F ceramic capacitors and one 0.1 $\mu$ F ceramic capacitor. Place the 0.01 $\mu$ F capacitors (one per  $V_{CC}$  input) as close to  $V_{CC}$  as possible (see the *Typical Operating Circuit*). Use multiple bypass vias to minimize parasitic inductance.

### Circuit Board Traces

Input and output trace characteristics affect the performance of the MAX9324. Connect each input and output to a 50 $\Omega$  characteristic impedance trace to minimize reflections. Avoid discontinuities in differential impedance and maximize common-mode noise immunity by maintaining the distance between differential traces and avoiding sharp corners. Minimize the number of vias to prevent impedance discontinuities. Minimize skew by matching the electrical length of the traces.

### Chip Information

TRANSISTOR COUNT: 4430

PROCESS: BiCMOS

### Functional Diagram

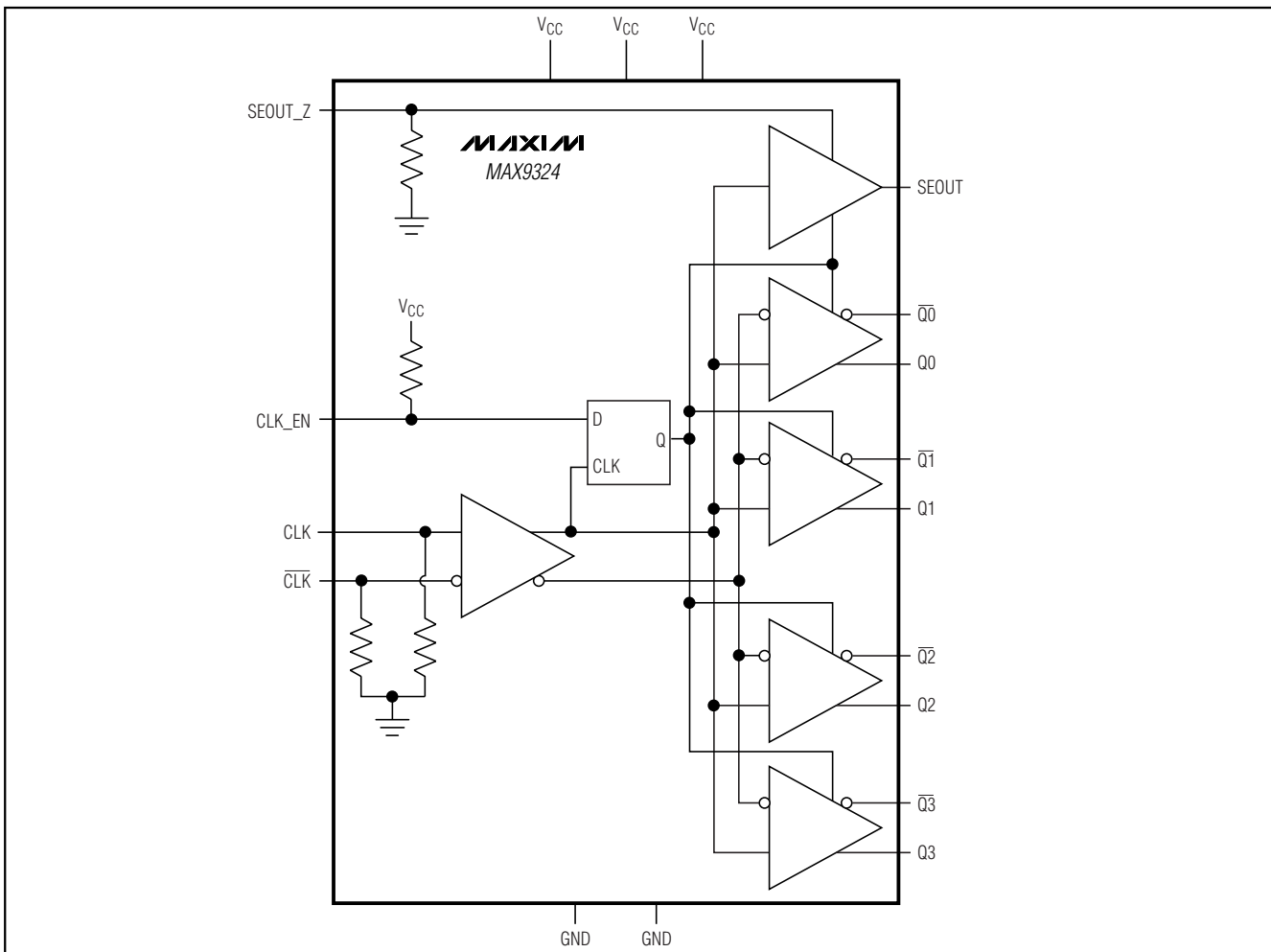

# One-to-Five LVPECL/LVCMOS Output Clock and Data Driver

Typical Operating Circuit

MAX9324

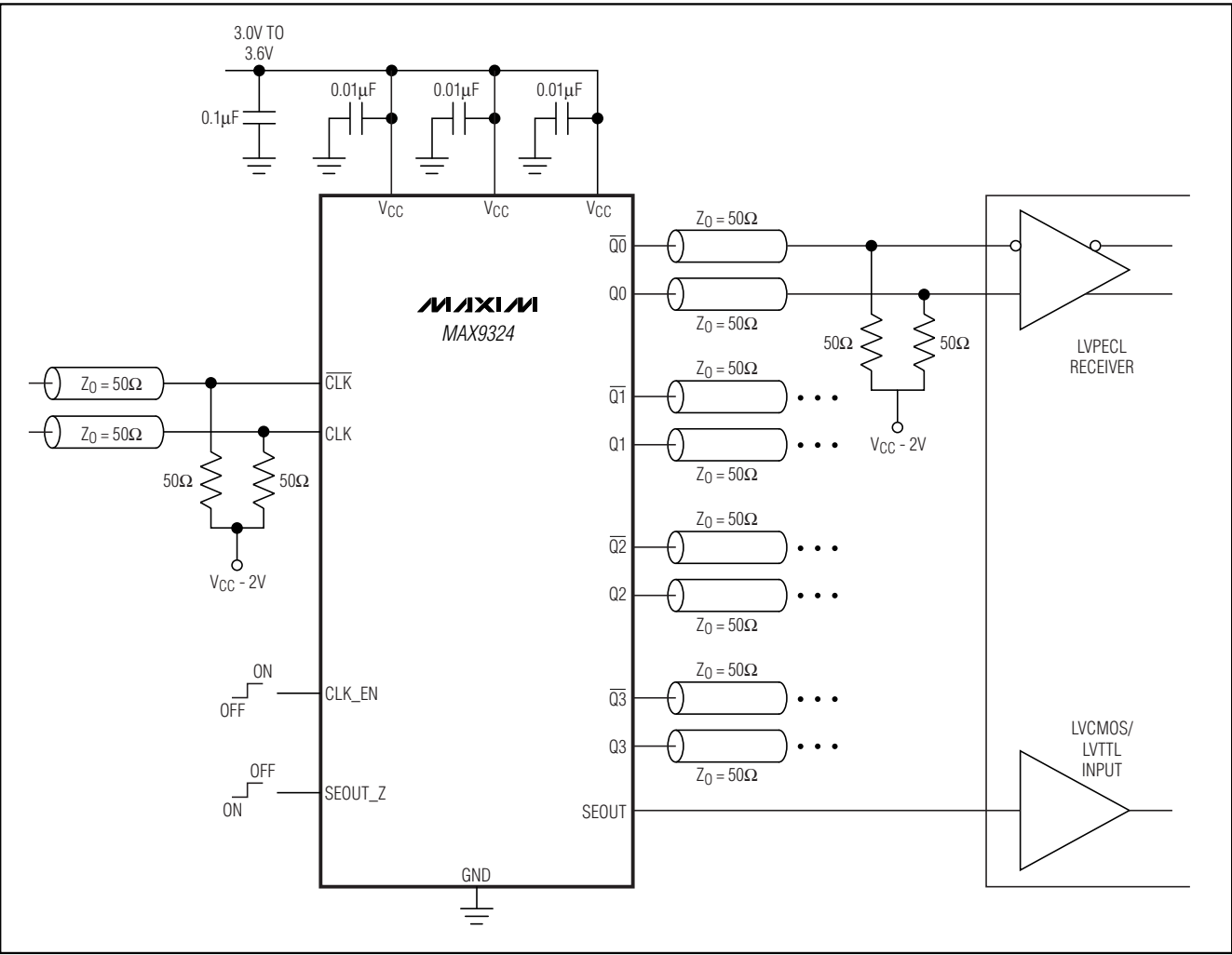

# One-to-Five LVPECL/LVCMOS Output Clock and Data Driver

## Package Information

(The package drawing(s) in this data sheet may not reflect the most current specifications. For the latest package outline information, go to [www.maxim-ic.com/packages](http://www.maxim-ic.com/packages).)

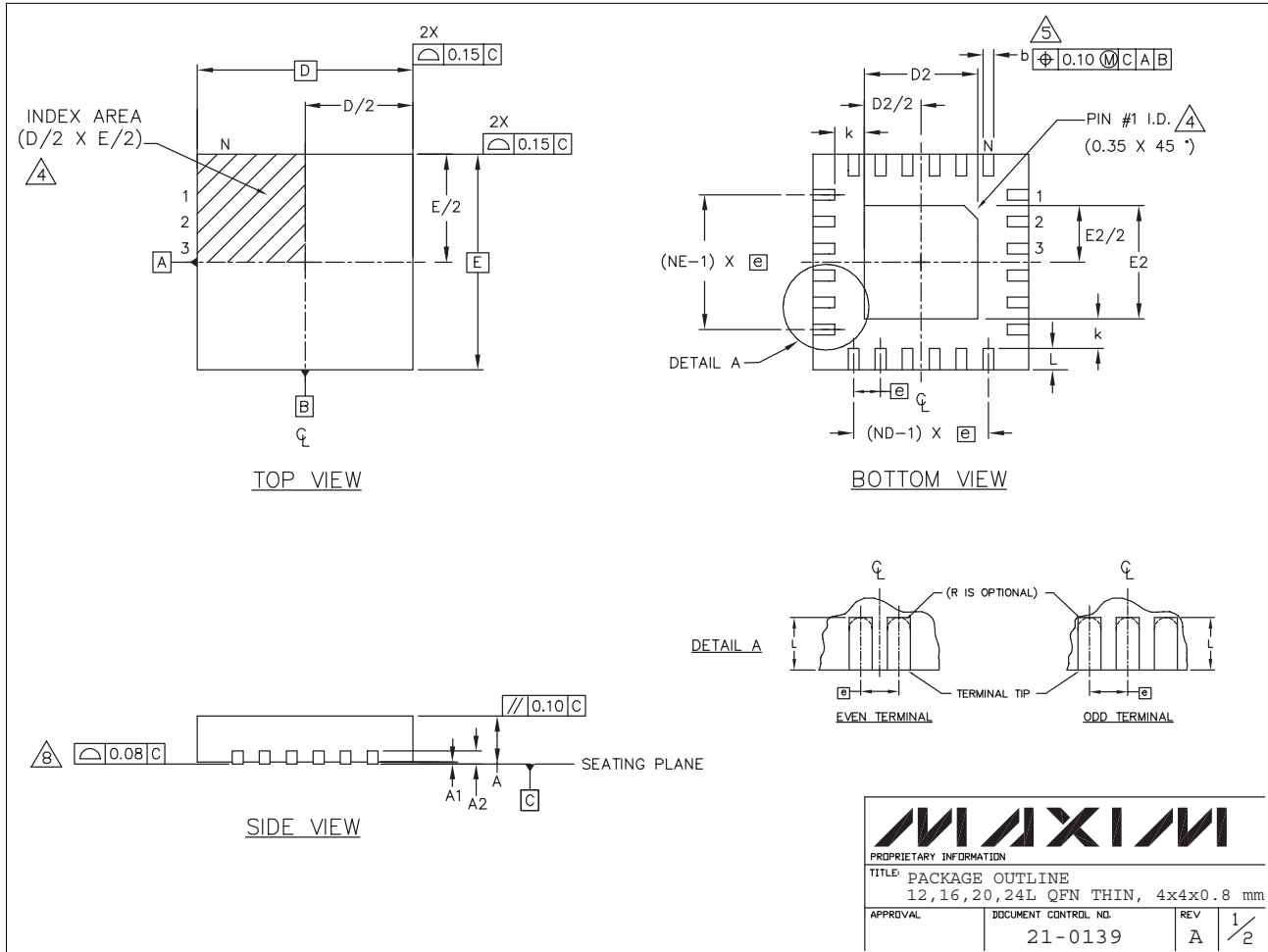

<b>MAXIM</b>			
PROPRIETARY INFORMATION			
TITLE: PACKAGE OUTLINE 12, 16, 20, 24L QFN THIN, 4x4x0.8 mm			
APPROVAL	DOCUMENT CONTROL NO.	REV	1/2
	21-0139	A	

# One-to-Five LVPECL/LVCMOS Output Clock and Data Driver

## Package Information (continued)

(The package drawing(s) in this data sheet may not reflect the most current specifications. For the latest package outline information, go to [www.maxim-ic.com/packages](http://www.maxim-ic.com/packages).)

COMMON DIMENSIONS												
PKG	12L 4x4			16L 4x4			20L 4x4			24L 4x4		
REF.	MIN.	NDM.	MAX.	MIN.	NDM.	MAX.	MIN.	NDM.	MAX.	MIN.	NDM.	MAX.
A	0.70	0.75	0.80	0.70	0.75	0.80	0.70	0.75	0.80	0.70	0.75	0.80
A1	0.0	0.02	0.05	0.0	0.02	0.05	0.0	0.02	0.05	0.0	0.02	0.05
A2	0.20 REF			0.20 REF			0.20 REF			0.20 REF		
b	0.25	0.30	0.35	0.25	0.30	0.35	0.20	0.25	0.30	0.18	0.23	0.30
D	3.90	4.00	4.10	3.90	4.00	4.10	3.90	4.00	4.10	3.90	4.00	4.10
E	3.90	4.00	4.10	3.90	4.00	4.10	3.90	4.00	4.10	3.90	4.00	4.10
e	0.80 BSC.			0.65 BSC.			0.50 BSC.			0.50 BSC.		
k	0.25	-	-	0.25	-	-	0.25	-	-	0.25	-	-
L	0.45	0.55	0.65	0.45	0.55	0.65	0.45	0.55	0.65	0.30	0.40	0.50
N	12			16			20			24		
ND	3			4			5			6		
NE	3			4			5			6		
Jedec Var.	WGGB			WGGC			WGGD-1			WGGD-2		

EXPOSED PAD VARIATIONS						
PKG. CODES	D2			E2		
	MIN.	NDM.	MAX.	MIN.	NDM.	MAX.
T1244-2	1.95	2.10	2.25	1.95	2.10	2.25
T1644-2	1.95	2.10	2.25	1.95	2.10	2.25
T2044-1	1.95	2.10	2.25	1.95	2.10	2.25
T2444-1	2.45	2.60	2.63	2.45	2.60	2.63

NOTES:

- DIMENSIONING & TOLERANCING CONFORM TO ASME Y14.5M-1994.
- ALL DIMENSIONS ARE IN MILLIMETERS. ANGLES ARE IN DEGREES.
- N IS THE TOTAL NUMBER OF TERMINALS.
- THE TERMINAL #1 IDENTIFIER AND TERMINAL NUMBERING CONVENTION SHALL CONFORM TO JESD 95-1 SPP-012. DETAILS OF TERMINAL #1 IDENTIFIER ARE OPTIONAL, BUT MUST BE LOCATED WITHIN THE ZONE INDICATED. THE TERMINAL #1 IDENTIFIER MAY BE EITHER A MOLD OR MARKED FEATURE.
- DIMENSION b APPLIES TO METALLIZED TERMINAL AND IS MEASURED BETWEEN 0.25 mm AND 0.30 mm FROM TERMINAL TIP.
- ND AND NE REFER TO THE NUMBER OF TERMINALS ON EACH D AND E SIDE RESPECTIVELY.
- DEPOPULATION IS POSSIBLE IN A SYMMETRICAL FASHION.
- COPLANARITY APPLIES TO THE EXPOSED HEAT SINK SLUG AS WELL AS THE TERMINALS.
- DRAWING CONFORMS TO JEDEC MO220.

PROPRIETARY INFORMATION			
TITLE: PACKAGE OUTLINE 12, 16, 20, 24L QFN THIN, 4x4x0.8 mm			
APPROVAL	DOCUMENT CONTROL NO.	REV	2/2
	21-0139	A	

# One-to-Five LVPECL/LVCMOS Output Clock and Data Driver

## Package Information (continued)

(The package drawing(s) in this data sheet may not reflect the most current specifications. For the latest package outline information, go to [www.maxim-ic.com/packages](http://www.maxim-ic.com/packages).)

**TOP VIEW**

**BOTTOM VIEW**

**SIDE VIEW**

**END VIEW**

**DETAIL A**

**LEAD TIP DETAIL**

SYMBOL	COMMON DIMENSIONS			
	MILLIMETERS		INCHES	
	MIN.	MAX.	MIN.	MAX.
A	—	1.10	—	.043
A <sub>1</sub>	0.05	0.15	.002	.006
A <sub>e</sub>	0.85	0.95	.033	.037
b	0.19	0.30	.007	.012
b <sub>1</sub>	0.19	0.25	.007	.010
c	0.09	0.20	.004	.008
c <sub>1</sub>	0.09	0.14	.004	.006
D	SEE VARIATIONS		SEE VARIATIONS	
E	4.30	4.50	.169	.177
e	0.65 BSC		.026 BSC	
H	6.25	6.55	.246	.258
L	0.50	0.70	.020	.028
N	SEE VARIATIONS		SEE VARIATIONS	
α	0°	8°	0°	8°

JEDEC	MO-153	N	VARIATIONS			
			MILLIMETERS		INCHES	
			MIN.	MAX.	MIN.	MAX.
			4.90	5.10	.193	.201
			4.90	5.10	.193	.201
			6.40	6.60	.252	.260
			7.70	7.90	.303	.311
			9.60	9.80	.378	.386

**NOTES:**

- DIMENSIONS D AND E DO NOT INCLUDE FLASH
- MOLD FLASH OR PROTRUSIONS NOT TO EXCEED 0.15mm PER SIDE
- CONTROLLING DIMENSION: MILLIMETER
- MEETS JEDEC OUTLINE MO-153. SEE JEDEC VARIATIONS TABLE
- 'N' REFERS TO NUMBER OF LEADS
- THE LEAD TIPS MUST LIE WITHIN A SPECIFIED ZONE. THIS TOLERANCE ZONE IS DEFINED BY TWO PARALLEL PLANES. ONE PLANE IS THE SEATING PLANE, DATUM [C-], THE OTHER PLANE IS AT THE SPECIFIED DISTANCE FROM [C-] IN THE DIRECTION INDICATED

**DALLAS SEMICONDUCTOR** **MAXIM**

PROPRIETARY INFORMATION

TITLE: PACKAGE OUTLINE, TSSOP 4.40mm BODY

APPROVAL	DOCUMENT CONTROL NO.	REV.	
	21-0066	F	1/1

TSSOP4.40mm.EPS

Maxim cannot assume responsibility for use of any circuitry other than circuitry entirely embodied in a Maxim product. No circuit patent licenses are implied. Maxim reserves the right to change the circuitry and specifications without notice at any time.

12 **Maxim Integrated Products, 120 San Gabriel Drive, Sunnyvale, CA 94086 408-737-7600**

## Looking for pricing, stock, or lifecycle information?

Click below to explore more details on WIN SOURCE:

 [View MAX9324EUP+](#) on WIN SOURCE

 [Maxim Integrated](#) Information

## Optimize Your Supply Chain with WIN SOURCE Solutions

-  Global Sourcing Solution
-  Obsolete Management
-  Cost Control Management
-  Shortage Management
-  Alternative Solution
-  Excess Inventory Management