



**THE DATASHEET OF
MAX9321BESA+**





Differential PECL/ECL/LVPECL/LVECL Receiver/Driver

MAX9321B

General Description

The MAX9321B low-skew differential receiver/driver is designed for clock and data distribution. The differential input can be adapted to accept a single-ended input by connecting the on-chip V_{BB} supply to an input as a reference voltage.

The MAX9321B features ultra-low propagation delay (172ps) and part-to-part skew (20ps) with 24mA maximum supply current, making this device ideal for clock buffering or repeating. For interfacing to differential PECL and LVPECL signals, these devices operate over a +3.0V to +5.5V supply range, allowing high-performance clock and data distribution in systems with a nominal 3.3V or 5.0V supply. For differential ECL and LVECL operation, this device operates from a -3.0V to -5.5V supply.

The MAX9321B is offered in industry-standard 8-pin SO and TSSOP packages.

Features

- ◆ Improved Second Source of the MC10EP16D
- ◆ +3.0V to +5.5V Differential PECL/LVPECL Operation
- ◆ -3.0V to -5.5V Differential ECL/LVECL Operation
- ◆ Low 17mA Supply Current
- ◆ 20ps Part-to-Part Skew
- ◆ 172ps Propagation Delay
- ◆ Minimum 300mV Output at 3GHz
- ◆ Output Low for Open Input
- ◆ ESD Protection >2kV (Human Body Model)
- ◆ On-Chip Reference for Single-Ended Input

Applications

- Precision Clock Buffer
- Low-Jitter Data Repeater

Ordering Information

PART	TEMP RANGE	PIN-PACKAGE
MAX9321BESA	-40°C to +85°C	8 SO
MAX9321BEUA*	-40°C to +85°C	8 TSSOP

*Future product—contact factory for availability.

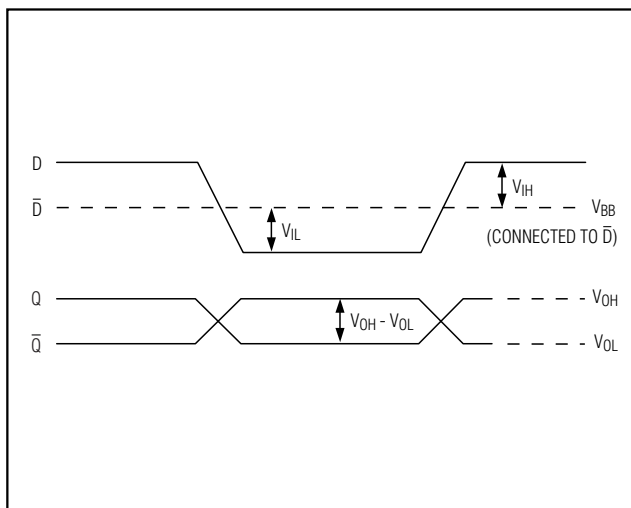
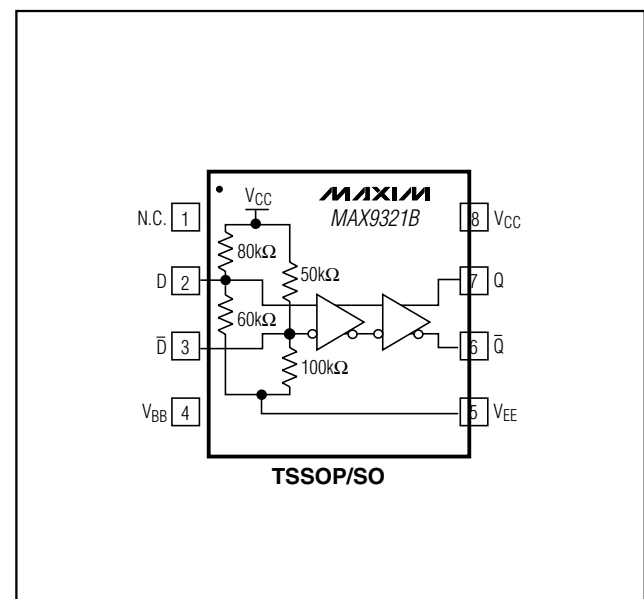

Figure 1. Switching with Single-Ended Inputs

Pin Configuration



Differential PECL/ECL/LVPECL/LVECL Receiver/Driver

ABSOLUTE MAXIMUM RATINGS

V _{CC} to V _{EE}	6.0V	Junction-to-Ambient Thermal Resistance with 500 LFPM Airflow	
D or \bar{D}	V _{EE} - 0.3V to V _{CC} + 0.3V	8-Pin TSSOP	+155°C/W
D or \bar{D} with the Other Input Floating	V _{CC} - 5.0V to V _{CC} + 0.3V	8-Pin SO	+99°C/W
D to \bar{D}	±3.0V	Junction-to-Case Thermal Resistance	
Continuous Output Current	50mA	8-Pin TSSOP	+39°C/W
Surge Output Current.....	100mA	8-Pin SO	+40°C/W
V _{BB} Sink/Source Current	±0.6mA	Operating Temperature Range	-40°C to +85°C
Continuous Power Dissipation (T _A +70°C)		Junction Temperature	+150°C
8-Pin TSSOP (derate 4.5mW/°C above +70°C)	362mW	Storage Temperature Range	-65°C to +150°C
8-Pin SO (derate 5.9mW/°C above +70°C).....	471mW	ESD Protection	
Junction-to-Ambient Thermal Resistance in Still Air		Human Body Model (D, \bar{D} , Q ₋ , \bar{Q} ₋)	>2kV
8-Pin TSSOP	+221°C/W	Soldering Temperature (10s).....	+300°C
8-Pin SO	+170°C/W		

Stresses beyond those listed under "Absolute Maximum Ratings" may cause permanent damage to the device. These are stress ratings only, and functional operation of the device at these or any other conditions beyond those indicated in the operational sections of the specifications is not implied. Exposure to absolute maximum rating conditions for extended periods may affect device reliability.

DC ELECTRICAL CHARACTERISTICS

(V_{CC} - V_{EE} = 3.0V to 5.5V, outputs loaded with 50Ω ±1% to V_{CC} - 2.0V. Typical values are at V_{CC} - V_{EE} = 5.0V, V_{IHD} = V_{CC} - 1V, V_{ILD} = V_{CC} - 1.5V, unless otherwise noted.) (Notes 1, 2, 3)

PARAMETER	SYMBOL	CONDITIONS	-40°C			+25°C			+85°C			UNITS
			MIN	TYP	MAX	MIN	TYP	MAX	MIN	TYP	MAX	
DIFFERENTIAL INPUT (D, \bar{D})												
Single-Ended Input High Voltage	V _{IH}	V _{BB} connected to \bar{D} (V _{IL} for V _{BB} connected to D), Figure 1	V _{CC} - 1.21		V _{CC}	V _{CC} - 1.145		V _{CC}	V _{CC} - 1.085		V _{CC}	V
Single-Ended Input Low Voltage	V _{IL}	V _{BB} connected to \bar{D} (V _{IH} for V _{BB} connected to D), Figure 1 (Note 4)	V _{EE}		V _{CC} - 1.61	V _{EE}		V _{CC} - 1.545	V _{EE}		V _{CC} - 1.485	V
High Voltage of Differential Input	V _{IHD}		V _{EE} + 1.2		V _{CC}	V _{EE} + 1.2		V _{CC}	V _{EE} + 1.2		V _{CC}	V
Low Voltage of Differential Input	V _{ILD}		V _{EE}		V _{CC} - 0.1	V _{EE}		V _{CC} - 0.1	V _{EE}		V _{CC} - 0.1	V
Differential Input Voltage	V _{IHD} - V _{ILD}		0.1		3.0	0.1		3.0	0.1		3.0	V
Input High Current	I _{IH}				150			150			150	μA
D Input Low Current	I _{ILD}	V _{CC} - V _{EE} ≤ 3.8V	-100		+100	-100		+100	-100		+100	μA
		V _{CC} - V _{EE} ≥ 3.8V	-140		+140	-140		+140	-140		+140	
\bar{D} Input Low Current	I _{ILD}	V _{CC} - V _{EE} ≤ 3.8V	-150		+150	-150		+150	-150		+150	μA
		V _{CC} - V _{EE} ≥ 3.8V	-175		+175	-175		+175	-175		+175	

Differential PECL/ECL/LVPECL/LVECL Receiver/Driver

MAX9321B

DC ELECTRICAL CHARACTERISTICS (continued)

($V_{CC} - V_{EE} = 3.0V$ to $5.5V$, outputs loaded with $50\Omega \pm 1\%$ to $V_{CC} - 2.0V$. Typical values are at $V_{CC} - V_{EE} = 5.0V$, $V_{IHD} = V_{CC} - 1V$, $V_{ILD} = V_{CC} - 1.5V$, unless otherwise noted.) (Notes 1, 2, 3)

PARAMETER	SYMBOL	CONDITIONS	-40°C			+25°C			+85°C			UNITS
			MIN	TYP	MAX	MIN	TYP	MAX	MIN	TYP	MAX	
DIFFERENTIAL OUTPUT (Q, \bar{Q})												
Single-Ended Output High Voltage	V_{OH}	Figure 1	$V_{CC} - 1.135$	$V_{CC} - 0.885$		$V_{CC} - 1.07$	$V_{CC} - 0.82$		$V_{CC} - 1.01$	$V_{CC} - 0.76$		V
Single-Ended Output Low Voltage	V_{OL}	Figure 1	$V_{CC} - 1.935$	$V_{CC} - 1.68$		$V_{CC} - 1.87$	$V_{CC} - 1.62$		$V_{CC} - 1.81$	$V_{CC} - 1.56$		V
Differential Output Voltage	$V_{OH} - V_{OL}$	Figure 1	550	820		550	820		550	820		mV
REFERENCE (V_{BB})												
Reference Voltage Output	V_{BB}	$I_{BB} = \pm 0.5mA$ (Note 5)	$V_{CC} - 1.51$	$V_{CC} - 1.31$		$V_{CC} - 1.445$	$V_{CC} - 1.245$		$V_{CC} - 1.385$	$V_{CC} - 1.185$		V
POWER SUPPLY												
Supply Current	I_{EE}	(Note 6)	16	24		17	24		18	24		mA

AC ELECTRICAL CHARACTERISTICS

($V_{CC} - V_{EE} = 3.0V$ to $5.5V$, outputs loaded with $50\Omega \pm 1\%$ to $V_{CC} - 2V$, input frequency $\leq 1.5GHz$, input transition time = 125ps (20% to 80%), $V_{IHD} = V_{EE} + 1.2V$ to V_{CC} , $V_{ILD} = V_{EE}$ to $V_{CC} - 0.15V$, $V_{IHD} - V_{ILD} = 0.15V$ to $3.0V$. Typical values are at $V_{CC} - V_{EE} = 5V$, $V_{IHD} = V_{CC} - 1V$, $V_{ILD} = V_{CC} - 1.5V$, unless otherwise noted.) (Notes 1, 7)

PARAMETER	SYMBOL	CONDITIONS	-40°C			+25°C			+85°C			UNITS
			MIN	TYP	MAX	MIN	TYP	MAX	MIN	TYP	MAX	
Differential Input-to-Output Delay	t_{PLHD} , t_{PHLD}	Figure 2	145	184	235	145	172	245	130	167	230	ps
Part-to-Part Skew	t_{SKPP}	(Note 8)		25	90		20	100		20	100	ps
Added Random Jitter	t_{RJ}	$f_{IN} = 1.5GHz$, clock pattern (Note 9)		1.7	2.8		1.7	2.8		1.7	2.8	ps (RMS)
		$f_{IN} = 3.0GHz$, clock pattern (Note 9)		0.6	1.5		0.6	1.5		0.6	1.5	

Differential PECL/ECL/LVPECL/LVECL Receiver/Driver

AC ELECTRICAL CHARACTERISTICS (continued)

($V_{CC} - V_{EE} = 3.0V$ to $5.5V$, outputs loaded with $50\Omega \pm 1\%$ to $V_{CC} - 2V$, input frequency $\leq 1.5GHz$, input transition time = $125ps$ (20% to 80%), $V_{IHD} = V_{EE} + 1.2V$ to V_{CC} , $V_{ILD} = V_{EE}$ to $V_{CC} - 0.15V$, $V_{IHD} - V_{ILD} = 0.15V$ to $3.0V$. Typical values are at $V_{CC} - V_{EE} = 5V$, $V_{IHD} = V_{CC} - 1V$, $V_{ILD} = V_{CC} - 1.5V$, unless otherwise noted.) (Notes 1, 7)

PARAMETER	SYMBOL	CONDITIONS	-40°C			+25°C			+85°C			UNITS
			MIN	TYP	MAX	MIN	TYP	MAX	MIN	TYP	MAX	
Added Deterministic Jitter	t_{DJ}	3.0Gpbs 2 ²³ - 1 PRBS pattern (Note 9)		57	80		57	80		57	80	ps (P-P)
Switching Frequency	f_{MAX}	$V_{OH} - V_{OL} \geq 300mV$, clock pattern, Figure 2	3.0			3.0			3.0			GHz
		$V_{OH} - V_{OL} \geq 550mV$, clock pattern, Figure 2	2.0			2.0			2.0			
Output Rise/ Fall Time (20% to 80%)	t_R, t_F	Figure 2	65	112	135	65	118	135	65	121	135	ps

Note 1: Measurements are made with the device in thermal equilibrium.

Note 2: Current into a pin is defined as positive. Current out of a pin is defined as negative.

Note 3: DC parameters production tested at $T_A = +25^\circ C$. Guaranteed by design and characterization over the full operating temperature range.

Note 4: Maximum differential input voltage limit of $\pm 3V$ also applies to single-ended use.

Note 5: Use V_{BB} as a reference for inputs on the same device only.

Note 6: All pins open except V_{CC} and V_{EE} .

Note 7: Guaranteed by design and characterization. Limits are set at $\pm 6\sigma$.

Note 8: Measured between outputs of different parts at the signal crossing points under identical conditions for a same-edge transition.

Note 9: Device jitter added to the input signal.

Differential PECL/ECL/LVPECL/LVECL Receiver/Driver

MAX9321B

Typical Operating Characteristics

($V_{CC} = 5V$, $V_{EE} = 0V$, input transition time = 125ps (20% to 80%), $V_{IHD} = V_{CC} - 1V$, $V_{ILD} = V_{CC} - 1.5V$, $f_{IN} = 1.5GHz$, outputs loaded with 50Ω to $V_{CC} - 2V$, $T_A = +25^\circ C$, unless otherwise noted.)

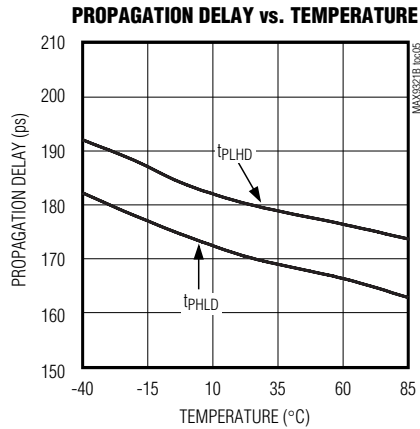
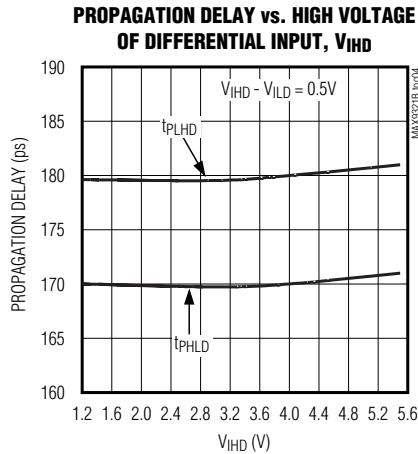
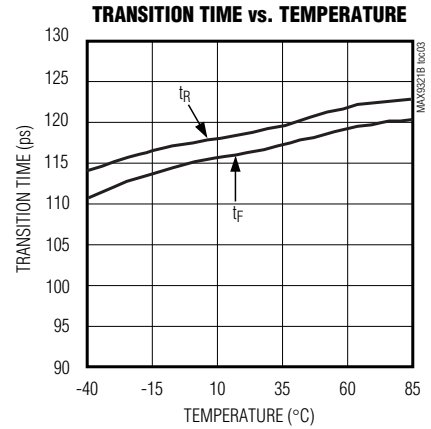
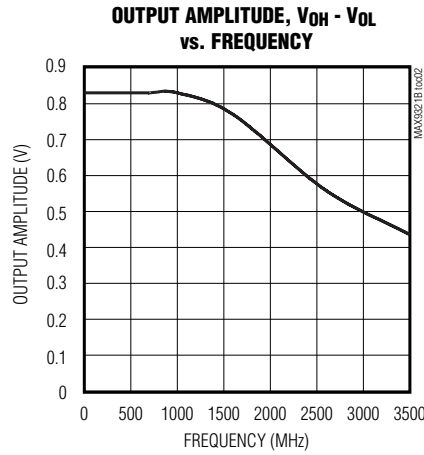
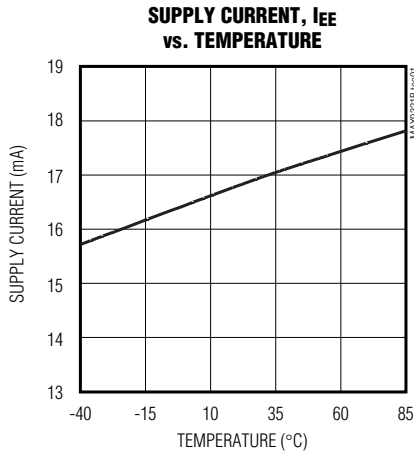

Differential PECL/ECL/LVPECL/LVECL Receiver/Driver

Pin Description

PIN	NAME	FUNCTION
1	N.C.	No Connection
2	D	Noninverting Differential Input. 80k Ω pullup to V _{CC} , 60k Ω pulldown to V _{EE} .
3	\bar{D}	Inverting Differential Input. 50k Ω pullup to V _{CC} and 100k Ω pulldown to V _{EE} .
4	V _{BB}	Reference Output Voltage. Connect to the inverting or noninverting input to provide a reference for single-ended operation. When used, bypass with a 0.01 μ F ceramic capacitor to V _{CC} ; otherwise leave open.
5	V _{EE}	Negative Supply Voltage
6	\bar{Q}	Inverting Output. Typically terminate with 50 Ω resistor to V _{CC} - 2V.
7	Q	Noninverting Output. Typically terminate with 50 Ω resistor to V _{CC} - 2V.
8	V _{CC}	Positive Supply Voltage. Bypass from V _{CC} to V _{EE} with 0.1 μ F and 0.01 μ F ceramic capacitors. Place the capacitors as close to the device as possible with the smaller value capacitor closest to the device.

Detailed Description

The MAX9321B low-skew differential receiver/driver is designed for clock and data distribution. For interfacing to differential PECL/LVPECL signals, this device operates over a +3.0V to +5.5V supply range, allowing high-performance clock and data distribution in systems with a nominal 3.3V or 5V supply. For differential ECL/LVECL operation, this device operates from a -3.0V to -5.5V supply.

Inputs

The differential input can be configured to accept a single-ended input. This is accomplished by connecting the on-chip reference voltage, V_{BB}, to an input as a reference. For example, the differential input is converted to a noninverting, single-ended input by connecting V_{BB} to \bar{D} and connecting the single-ended input to D. An inverting input is obtained by connecting V_{BB} to D and connecting the single-ended input to \bar{D} .

When using the V_{BB} reference output, bypass it with a 0.01 μ F ceramic capacitor to V_{CC}. If the V_{BB} reference is not used, it can be left open. The V_{BB} reference can source or sink 0.5mA. Use V_{BB} only for an input on the same device as the V_{BB} reference.

The maximum magnitude of the differential input from D to \bar{D} is 3.0V. This limit also applies to the difference between any reference voltage input and a single-ended input.

The differential input has bias resistors that drive the output to a differential low when the inputs are open. The inverting input is biased with a 50k Ω pullup to V_{CC} and a 100k Ω pulldown to V_{EE}. The noninverting input is biased with an 80k Ω pullup to V_{CC} and a 60k Ω pulldown to V_{EE}.

Specifications for the high and low voltage of the differential input (V_{IHD} and V_{ILD}) and the differential input voltage (V_{IHD} - V_{ILD}) apply simultaneously (V_{ILD} cannot be higher than V_{IHD}).

Outputs

Output levels are referenced to V_{CC} and are considered PECL/LVPECL or ECL/LVECL, depending on the level of the V_{CC} supply. With V_{CC} connected to a positive supply and V_{EE} connected to GND, the output is PECL/LVPECL. The output is ECL/LVECL when V_{CC} is connected to GND and V_{EE} is connected to a negative supply.

A single-ended input of at least V_{BB} \pm 100mV or a differential input of at least \pm 100mV switches the outputs to the V_{OH} and V_{OL} levels specified in the *DC Electrical Characteristics* table.

Applications Information

Supply Bypassing

Bypass V_{CC} to V_{EE} with high-frequency surface-mount ceramic 0.1 μ F and 0.01 μ F capacitors in parallel as close to the device as possible, with the 0.01 μ F value capacitor closest to the device. Use multiple parallel ground vias for low inductance. When using the V_{BB} reference output, bypass it with a 0.01 μ F ceramic capacitor to V_{CC} (if the V_{BB} reference is not used, it can be left open).

Traces

Input and output trace characteristics affect the performance of the MAX9321B. Connect each signal of a differential input or output to a 50 Ω characteristic impedance trace. Minimize the number of vias to prevent impedance discontinuities. Reduce reflections by maintaining the 50 Ω characteristic impedance through connectors and

Differential PECL/ECL/LVPECL/LVECL Receiver/Driver

MAX9321B

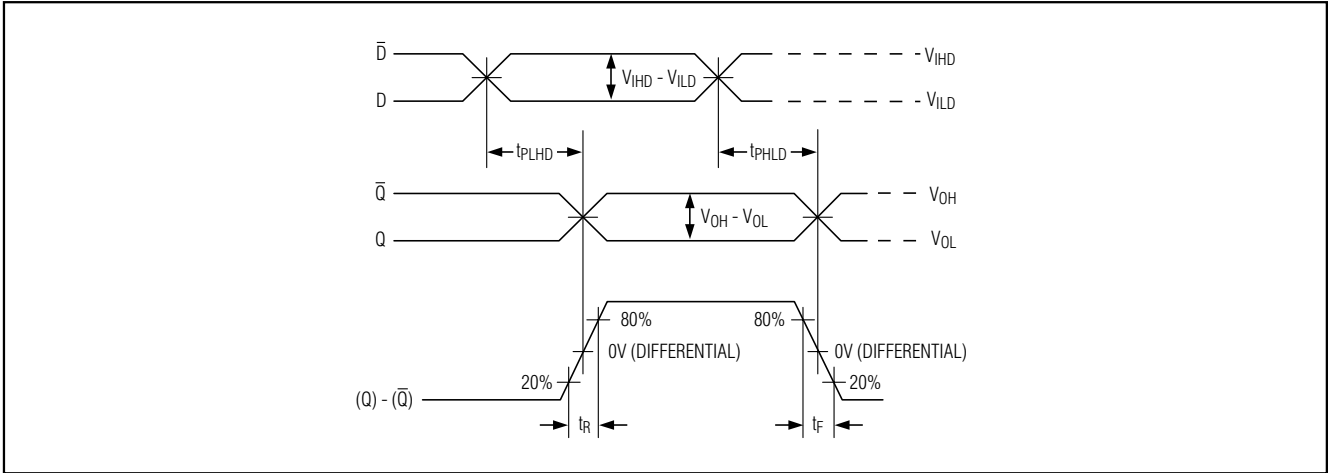

Figure 2. Differential Transition Time and Propagation Delay Timing Diagram

across cables. Reduce skew within a differential pair by matching the electrical length of the traces.

Output Termination

Terminate outputs through 50Ω to $V_{CC} - 2V$ or use an equivalent Thevenin termination. When a single-ended signal is taken from the differential output, terminate both outputs. For example, when Q is used as a single-ended output, terminate both Q and \bar{Q} .

Chip Information

TRANSISTOR COUNT: 162

Package Information

For the latest package outline information, go to www.maxim-ic.com/packages.

Maxim cannot assume responsibility for use of any circuitry other than circuitry entirely embodied in a Maxim product. No circuit patent licenses are implied. Maxim reserves the right to change the circuitry and specifications without notice at any time.

Maxim Integrated Products, 120 San Gabriel Drive, Sunnyvale, CA 94086 408-737-7600 _____ 7

Looking for pricing, stock, or lifecycle information?

Click below to explore more details on WIN SOURCE:

- ⊖ [View MAX9321BESA+ on WIN SOURCE](#)
- ⊖ [Maxim Integrated Information](#)

Optimize Your Supply Chain with WIN SOURCE Solutions

- ✓ Global Sourcing Solution
- ✓ Obsolete Management
- ✓ Cost Control Management
- ✓ Shortage Management
- ✓ Alternative Solution
- ✓ Excess Inventory Management