



**THE DATASHEET OF
MAX9163ESA+**



MAXIM

Bus LVDS 3.3V Single Transceiver

MAX9163

General Description

The MAX9163 high-speed bus low-voltage differential signaling (BLVDS) transceiver is designed specifically for heavily loaded multipoint bus applications. The MAX9163 operates from a single 3.3V power supply, and is pin compatible with the DS92LV010A. The transceiver consists of one differential BLVDS line driver and one LVDS receiver. The driver output and receiver input are connected internally to minimize bus loading. The individual enable logic inputs (DE, \overline{RE}) are used to enable the driver or the receiver.

The MAX9163 driver output uses a current-steering configuration to generate a 9mA (typ) drive current. The driver accepts a single-ended input and translates it to a differential output level of 243mV (typ) into 27Ω at speeds up to 200Mbps. The MAX9163 receiver detects a differential input as low as 100mV and translates it to a single-ended output at speeds up to 200Mbps. The receiver input features a fail-safe circuit that sets the receiver output high when the receiver inputs are undriven and open, terminated, or shorted.

The MAX9163 is offered in an 8-lead SO package, and is specified for operation from -40°C to $+85^{\circ}\text{C}$.

Applications

- Cell-Phone Base Stations
- Add/Drop Muxes
- Digital Cross-Connects
- DSLAMs
- Network Switches/Routers
- Backplane Interconnect
- Clock Distribution

Features

- ◆ BLVDS Signaling
- ◆ 3.3V Operation
- ◆ Low-Power CMOS Design
- ◆ 200Mbps Data-Signaling Rate
- ◆ $\pm 1\text{V}$ Common-Mode Range
- ◆ $\pm 100\text{mV}$ Receiver Sensitivity
- ◆ Flow-Through Pinout
- ◆ Receiver Output High for Undriven Open, Short, or Terminated Input
- ◆ 8-Lead SO Package

Ordering Information

PART	TEMP RANGE	PIN-PACKAGE
MAX9163ESA	-40°C to $+85^{\circ}\text{C}$	8 SO

Pin Configuration

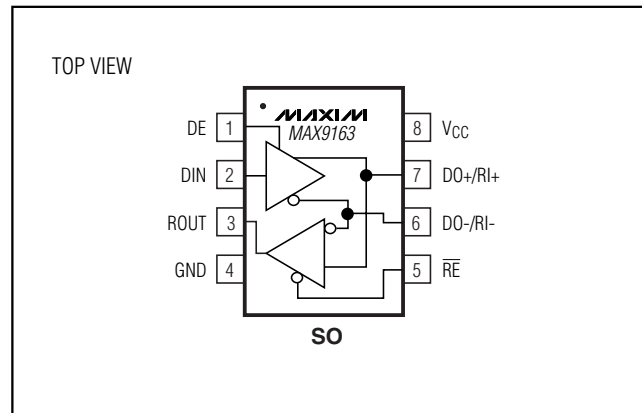

Typical Application Circuit appears at end of data sheet.

Bus LVDS 3.3V Single Transceiver

ABSOLUTE MAXIMUM RATINGS

V _{CC} to GND	-0.3V to +4.0V	Operating Temperature Range	-40°C to +85°C
DO+/RI+, DO-/RI- to GND	-0.3V to +4.0V	Junction Temperature	+150°C
DIN, ROUT, DE, \overline{RE} to GND	-0.3V to (V _{CC} + 0.3V)	Storage Temperature Range	-65°C to +150°C
Driver Short-Circuit Current	Continuous	ESD Protection	
Continuous Power Dissipation (T _A = +70°C)		HBM (1.5k Ω , 100pF),	
8-Pin SO (derate 5.9mW/°C above +70°C).....	471mW	DO+/RI+, DO-/RI-, DIN, ROUT, DE, \overline{RE}	> ± 2 kV
		Lead Temperature (soldering, 10s)	+300°C

Stresses beyond those listed under "Absolute Maximum Ratings" may cause permanent damage to the device. These are stress ratings only, and functional operation of the device at these or any other conditions beyond those indicated in the operational sections of the specifications is not implied. Exposure to absolute maximum rating conditions for extended periods may affect device reliability.

DC ELECTRICAL CHARACTERISTICS

(V_{CC} = 3.0V to 3.6V, \overline{RE} = 0, |V_{ID}| = 0.1V to 2.9V, common-mode input voltage (V_{CM}) = |V_{ID}|/2 to 3.0V - |V_{ID}|/2, R_L = 27 Ω \pm 1%, T_A = -40°C to +85°C. Typical values are at V_{CC} = 3.3V, |V_{ID}| = 0.2V, V_{CM} = 1.2V, T_A = +25°C, unless otherwise noted.) (Notes 1, 2)

PARAMETER	SYMBOL	CONDITIONS	MIN	TYP	MAX	UNITS
SINGLE-ENDED INPUTS (DIN, DE, \overline{RE})						
Input High Voltage	V _{IH}		2.0		V _{CC}	V
Input Low Voltage	V _{IL}		0		0.8	V
Input Current	I _{IN}	\overline{RE} , DE, DIN = high or low	-10		+10	μ A
Input Diode Clamp Voltage	V _{CL}	I _{CLAMP} = -18mA	-1.5			V
DRIVER OUTPUT (DO+/RI+, DO-/RI-)						
Differential Output Voltage	V _{OD}	Figure 1	180	250	360	mV
Change in Magnitude of V _{OD} Between Complementary Output States	Δ V _{OD}	Figure 1		0.2	25	mV
Offset Voltage	V _{OS}	Figure 1	1.00	1.28	1.65	V
Change in Magnitude of V _{OS} Between Complementary Output States	Δ V _{OS}	Figure 1		1.4	25	mV
Output Short-Circuit Current	I _{OSD}	DO+/RI+ = 0, DIN = V _{CC}		-9	-20	mA
		DO-/RI- = 0, DIN = 0		-9	-20	
Output Capacitance	C _{OUT}	Capacitance from DO+/RI+ or DO-/RI- to GND		6.9		pF
RECEIVER INPUT (DO+/RI+, DO-/RI-)						
Differential Input High Threshold	V _{TH}	DE = low			100	mV
Differential Input Low Threshold	V _{TL}	DE = low	-100			mV
Input Current	I _{IN}	DE = low, V _{CC} = 0 or 3.6V; DO+/RI+, DO-/RI- = 2.4V or 0; Figure 6	-20		+20	μ A
RECEIVER OUTPUT (ROUT)						
Output High Voltage	V _{OH}	V _{ID} = +100mV	I _{OH} = -400 μ A, DE = Low	2.90	3.28	V
		Inputs open				
		Inputs shorted				
		Inputs terminated, R _L = 27 Ω				
Output Low Voltage	V _{OL}	I _{OL} = +2.0mA, V _{ID} = -100mV, DE = low		0.025	0.4	V
Output Short-Circuit Current	I _{OS}	V _{ID} = +100mV, ROUT = 0, DE = low	-5	-25	-85	mA

Bus LVDS 3.3V Single Transceiver

MAX9163

DC ELECTRICAL CHARACTERISTICS (continued)

($V_{CC} = 3.0V$ to $3.6V$, $\overline{RE} = 0$, $|V_{ID}| = 0.1V$ to $2.9V$, common-mode input voltage (V_{CM}) = $|V_{ID}|/2$ to $3.0V - |V_{ID}|/2$, $R_L = 27\Omega \pm 1\%$, $T_A = -40^\circ C$ to $+85^\circ C$. Typical values are at $V_{CC} = 3.3V$, $|V_{ID}| = 0.2V$, $V_{CM} = 1.2V$, $T_A = +25^\circ C$, unless otherwise noted.) (Notes 1, 2)

PARAMETER	SYMBOL	CONDITIONS	MIN	TYP	MAX	UNITS
SUPPLY CURRENT						
Supply Current	I_{CC}	$DE = V_{CC}$, $\overline{RE} = 0$		13.3	20	mA
Driver Supply Current	I_{CCD}	$DE = \overline{RE} = V_{CC}$		13.3	20	mA
Receiver Supply Current	I_{CCR}	$DE = \overline{RE} = 0$		4.4	8	mA
Disable Supply Current	I_{CCZ}	$DE = 0$, $\overline{RE} = V_{CC}$		4.4	7.5	mA

AC ELECTRICAL CHARACTERISTICS

($V_{CC} = 3.0V$ to $3.6V$, $|V_{ID}| = 0.2V$, $V_{CM} = 1.2V$, $R_L = 27\Omega \pm 1\%$, $C_L = 10pF$, $T_A = -40^\circ C$ to $+85^\circ C$. Typical values are at $V_{CC} = 3.3V$, $|V_{ID}| = 0.2V$, $V_{CM} = 1.2V$, $T_A = +25^\circ C$, unless otherwise noted.) (Notes 3, 4, 5)

PARAMETER	SYMBOL	CONDITIONS	MIN	TYP	MAX	UNITS
DRIVER, $DE = \overline{RE} = V_{CC}$						
Differential High-to-Low Propagation Delay	t_{PHLD}	Figure 2	1.0	3.2	5.0	ns
Differential Low-to-High Propagation Delay	t_{PLHD}	Figure 2	1.0	3.0	5.0	ns
Differential Skew $t_{PHLD} - t_{PLHD}$	t_{SKD}	Figure 2		0.2	1.0	ns
Rise Time	t_{TLHD}	Figure 2		0.8	2.0	ns
Fall Time	t_{THLD}	Figure 2		0.6	2.0	ns
Disable Time High to Z	t_{PHZ}	Figure 3	0.5	2.2	9.0	ns
Disable Time Low to Z	t_{PLZ}	Figure 3	0.5	2.2	10.0	ns
Enable Time Z to High	t_{PZH}	Figure 3	2.0	3.2	7.0	ns
Enable Time Z to Low	t_{PZL}	Figure 3	1.0	3.2	9.0	ns
RECEIVER, $DE = \overline{RE} = 0$						
Differential High-to-Low Propagation Delay	t_{PHL}	Figure 4	2.5	6.4	12.0	ns
Differential Low-to-High Propagation Delay	t_{PLH}	Figure 4	2.5	6.0	10.0	ns
Differential Skew $t_{PHL} - t_{PLH}$	t_{SKD}	Figure 4		0.4	2.0	ns
Rise Time	t_{TLH}	Figure 4		1.0	4.0	ns
Fall Time	t_{THL}	Figure 4		0.4	4.0	ns
Disable Time High to Z	t_{PHZ}	Figure 5	2.0	5.0	6.0	ns
Disable Time Low to Z	t_{PLZ}	Figure 5	2.0	4.4	7.0	ns
Enable Time Z to High	t_{PZH}	Figure 5	2.0	4.6	13.0	ns
Enable Time Z to Low	t_{PZL}	Figure 5	2.0	4.3	10.0	ns

Note 1: Maximum and minimum limits over temperature are guaranteed by design and characterization. Devices are 100% tested at $T_A = +25^\circ C$.

Note 2: Current into a pin is defined as positive. Current out of a pin is defined as negative. All voltages are referenced to device ground except V_{TH} , V_{TL} , V_{ID} , V_{OD} , and ΔV_{OD} .

Note 3: C_L includes probe and jig capacitance.

Note 4: AC parameters are guaranteed by design and characterization.

Note 5: Generator waveforms for all tests unless otherwise specified: $f = 100MHz$, $Z_0 = 50\Omega$, $t_R = t_F = 6.0ns$ (0 to 3V, 0% to 100%) for DE and \overline{RE} , $t_R = t_F = 3.0ns$ (0 to 3V, 0% to 100%) for DIN , and $t_R = t_F = 1.0ns$ ($|V_{ID}| = 0.2V$, 20% to 80%) for $DO+/RI+$ and $DO-/RI-$ inputs.

Bus LVDS 3.3V Single Transceiver

Test Circuits/Timing Diagrams

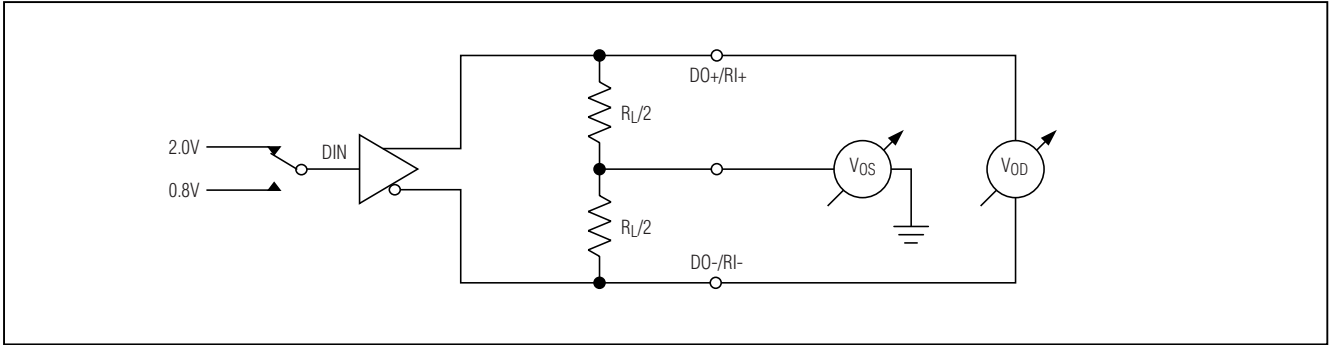

Figure 1. Differential Driver DC Test Circuit

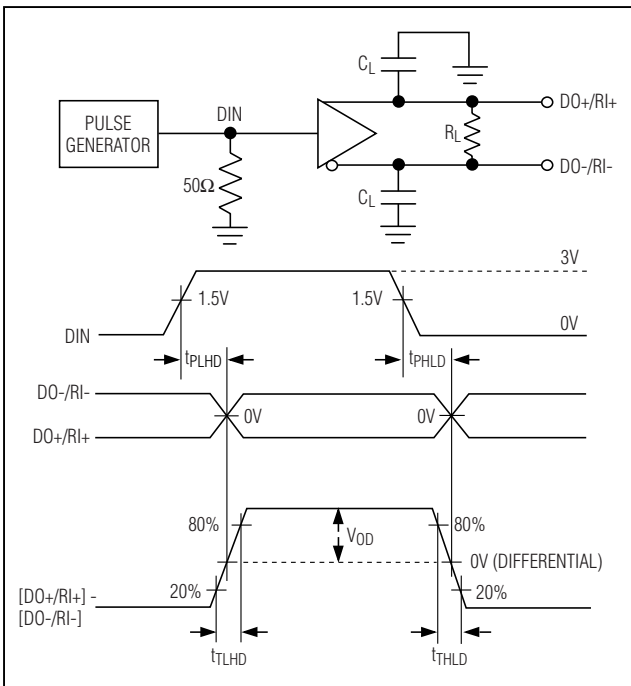

Figure 2. Driver Differential Propagation Delay and Transition Time Test Circuit and Waveforms

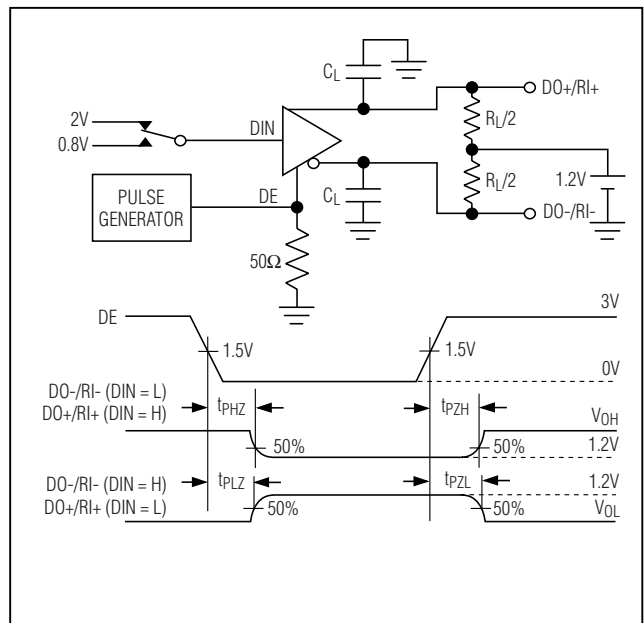

Figure 3. Driver High-Impedance Delay Test Circuit and Waveforms

Bus LVDS 3.3V Single Transceiver

MAX9163

Test Circuits/Timing Diagrams (continued)

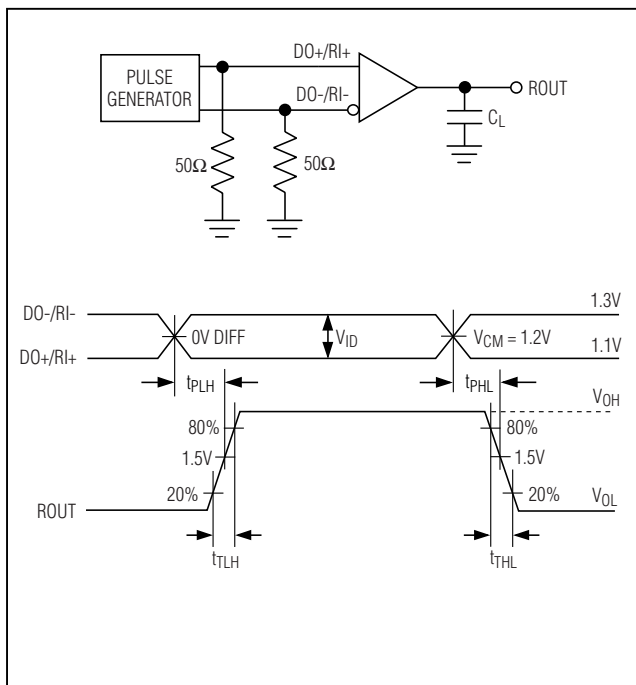

Figure 4. Receiver Propagation Delay and Transition Time Test Circuit and Waveforms

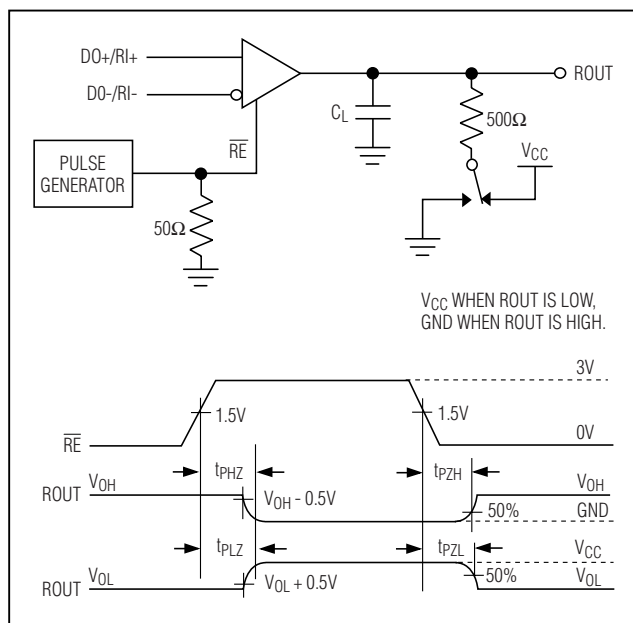
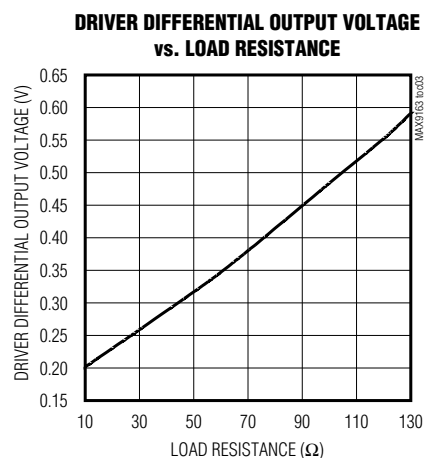
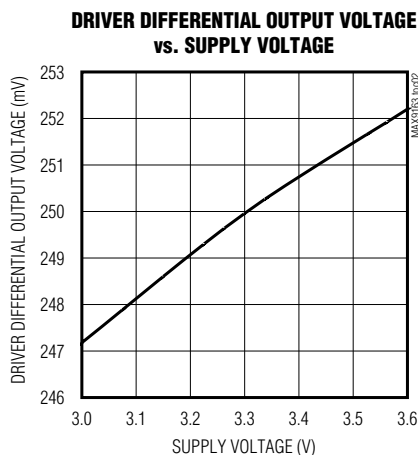
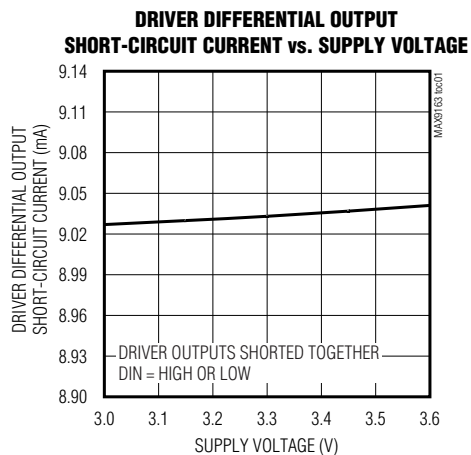

Figure 5. Receiver High-Impedance Delay Test Circuit and Waveforms

Typical Operating Characteristics

($V_{CC} = 3.3V$, $FREQ = 100MHz$, $V_{ID} = 0.2V$, $V_{CM} = 1.2V$, $R_L = 27\Omega \pm 1\%$, $C_L = 10pF$, $T_A = +25^\circ C$, unless otherwise noted.)



Bus LVDS 3.3V Single Transceiver

Typical Operating Characteristics (continued)

($V_{CC} = 3.3V$, $FREQ = 100MHz$, $V_{ID} = 0.2V$, $V_{CM} = 1.2V$, $R_L = 27\Omega \pm 1\%$, $C_L = 10pF$, $T_A = +25^\circ C$, unless otherwise noted.)

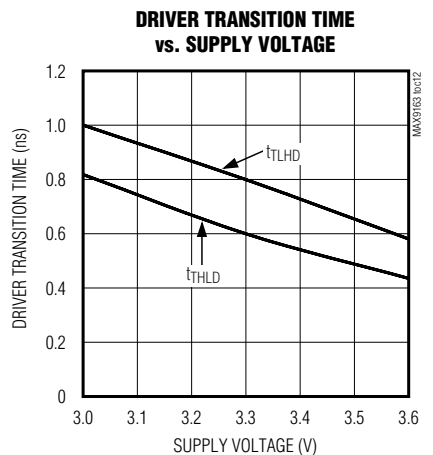
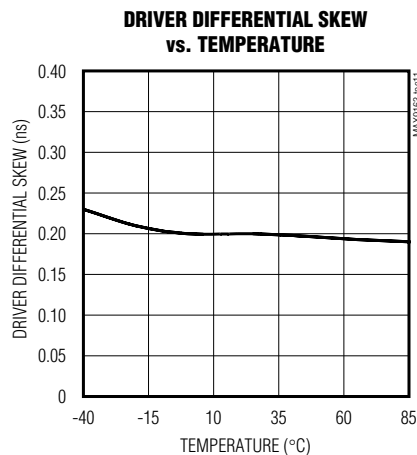
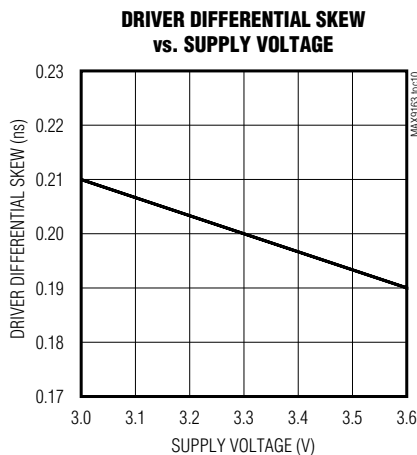
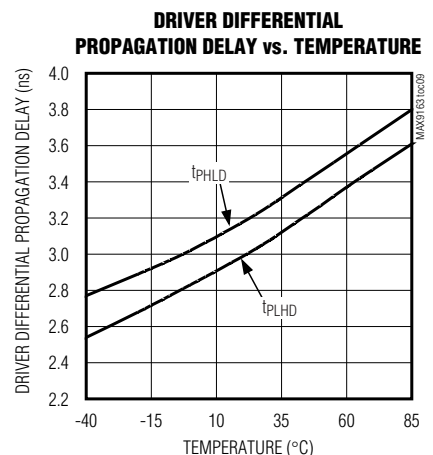
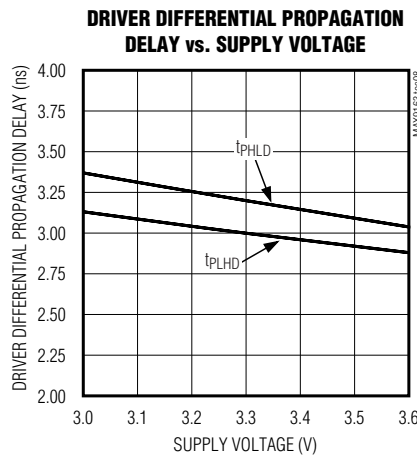
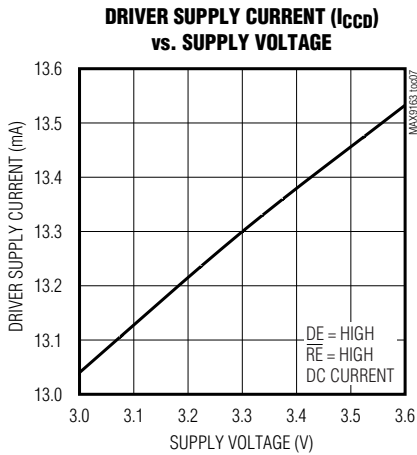
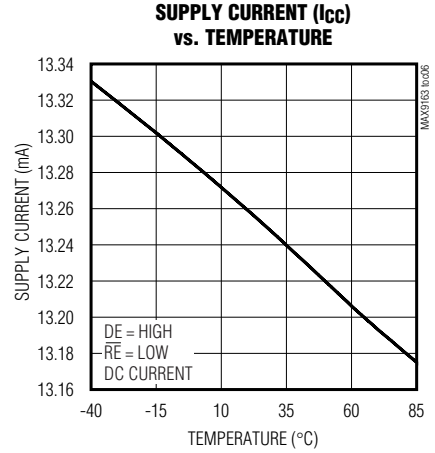
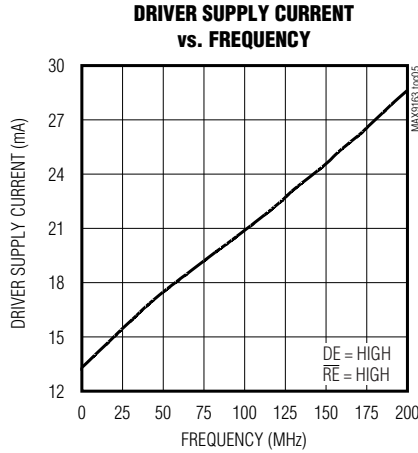
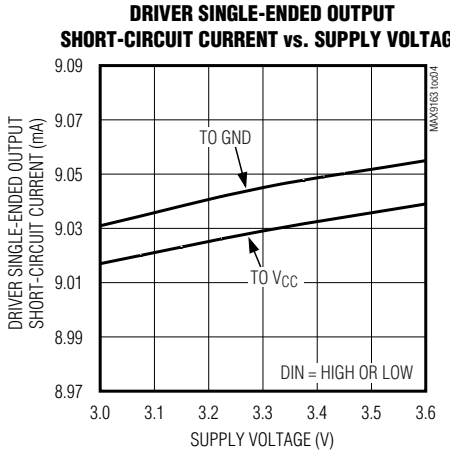

Bus LVDS 3.3V Single Transceiver

MAX9163

Typical Operating Characteristics (continued)

($V_{CC} = 3.3V$, $FREQ = 100MHz$, $V_{ID} = 0.2V$, $V_{CM} = 1.2V$, $R_L = 27\Omega \pm 1\%$, $C_L = 10pF$, $T_A = +25^\circ C$, unless otherwise noted.)

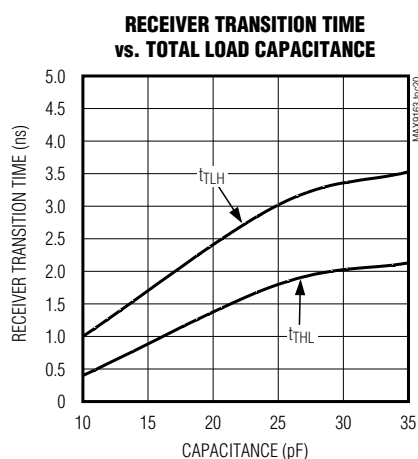
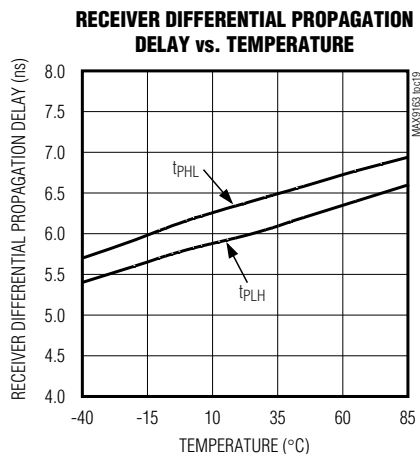
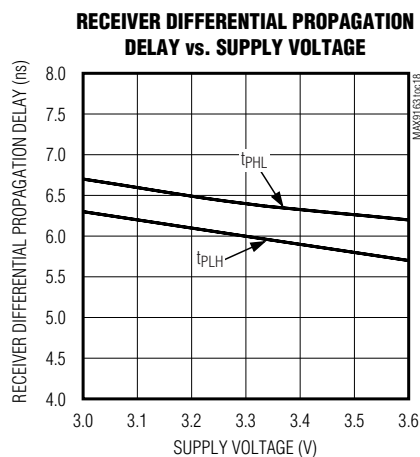
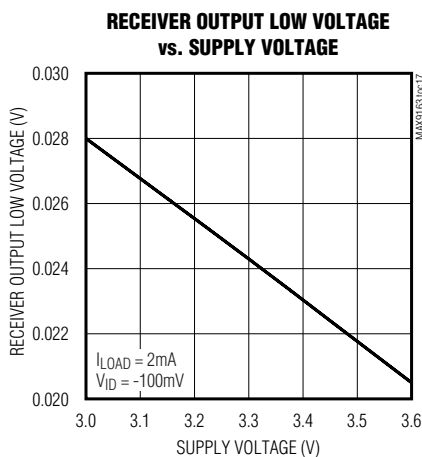
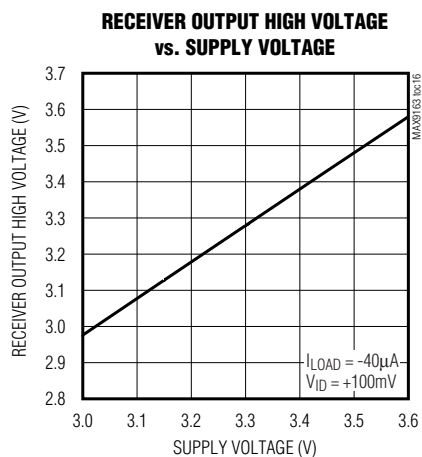
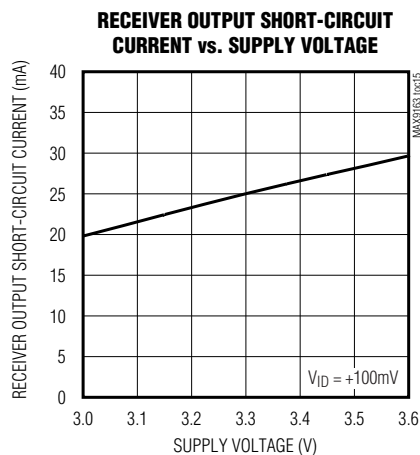
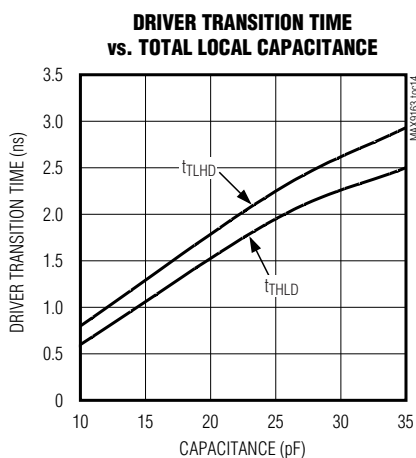
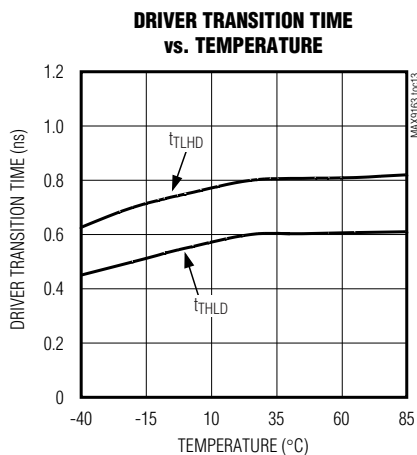

Bus LVDS 3.3V Single Transceiver

Pin Description

PIN	NAME	FUNCTION
1	DE	LVTTL/LVCMOS Driver Enable Input. The driver is enabled when DE is high. When DE is low, the driver output is disabled and is high impedance.
2	DIN	LVTTL/LVCMOS Driver Input
3	ROUT	LVTTL/LVCMOS Receiver Output
4	GND	Ground
5	\overline{RE}	LVTTL/LVCMOS Receiver Enable Input. The receiver is enabled when \overline{RE} is low. When \overline{RE} is high, the receiver output is disabled and is high impedance.
6	DO-/RI-	Inverting BLVDS Driver Output/Receiver Input
7	DO+/RI+	Noninverting BLVDS Driver Output/Receiver Input
8	V _{CC}	Power-Supply Input. Bypass V _{CC} to GND with 0.1 μ F and 0.001 μ F ceramic capacitors.

Detailed Description

The MAX9163 high-speed BLVDS transceiver is designed specifically for heavily loaded multipoint bus applications. The MAX9163 operates from a single 3.3V power supply, and is pin compatible with DS92LV010A. The transceiver consists of one differential BLVDS line driver and one LVDS receiver. The driver outputs and receiver inputs are connected internally to minimize bus loading. The driver and receiver can be enabled or disabled individually or simultaneously by the use of enable logic inputs (DE, \overline{RE}).

The MAX9163 driver output uses a current-steering configuration to generate a 9mA (typ) output current. This current-steering approach induces less ground bounce and no shoot-through current, enhancing noise margin and system speed performance. The outputs are short-circuit current limited. The MAX9163 current-steering output requires a resistive load to terminate the signal and complete the transmission loop. With a typical 9mA output current, the MAX9163 produces a 243mV output voltage when driving a bus terminated with two 54 Ω resistors (9mA x 27 Ω = 243mV).

The MAX9163 receiver detects a differential input as low as 100mV and translates it to a single-ended output. The device features an in-path fail-safe circuit that sets the receiver output high when the receiver inputs are undriven and open, terminated, or shorted.

Receiver In-Path Fail-Safe

The MAX9163 has in-path fail-safe circuitry, which is designed with a +35mV input offset voltage, a 2.5 μ A current source between V_{CC} and the noninverting input, and a 5 μ A current sink between the inverting input and ground (Figure 6). If the differential input is open, the 2.5 μ A current source pulls the input to about V_{CC} - 0.7V and the 5 μ A source sink pulls the inverting

input to ground, which drives the receiver output high. If the differential input is shorted or terminated with a typical value termination resistor, the +35mV offset drives the receiver output high. If the input is terminated and floating, the receiver output is driven high by the +35mV offset, and the 2:1 current sink to current source ratio (5 μ A:2.5 μ A) pulls the inputs to ground. This can be an advantage when switching between drivers on a multipoint bus. The change in common-mode voltage on the MAX9163 is from ground to the typical driver offset voltage of 1.2V. This is less than the change from V_{CC} to 1.2V found on some circuits where the fail-safe circuitry pulls the bus to V_{CC}.

Effects of Capacitive Loading

The characteristic impedance of a differential PC board trace is uniformly reduced when equal capacitive loads are attached at equal intervals (provided that the transition time of the signal being driven on the trace is longer than the delay between loads). This kind of loading is typical of multipoint buses where cards are attached at 1in or 0.8in intervals along the length of a backplane. The reduction in characteristic impedance is approximated by the following formula:

$$Z_{DF\text{-loaded}} = Z_{DF\text{-unloaded}} \times \sqrt{\left[\frac{C_O}{C_O + (N \times C_L / L)} \right]}$$

where:

Z_{DF-unloaded} = unloaded differential characteristic impedance

C_O = unloaded trace capacitance (pF/unit length)

C_L = value of each capacitive load (pF)

N = number of capacitive loads

L = trace length

Bus LVDS 3.3V Single Transceiver

For example, if $C_O = 2.5\text{pF/in}$, $C_L = 10\text{pF}$, $N = 18$, $L = 18\text{in}$, and $Z_{DF-unloaded} = 120\Omega$, the loaded differential impedance is:

$$Z_{DF-loaded} = 120\Omega \times \sqrt{[2.5\text{pF} / (2.5\text{pF} + (18 \times 10\text{pF} / 18\text{in}))]}$$

where $Z_{DF-loaded} = 54\Omega$

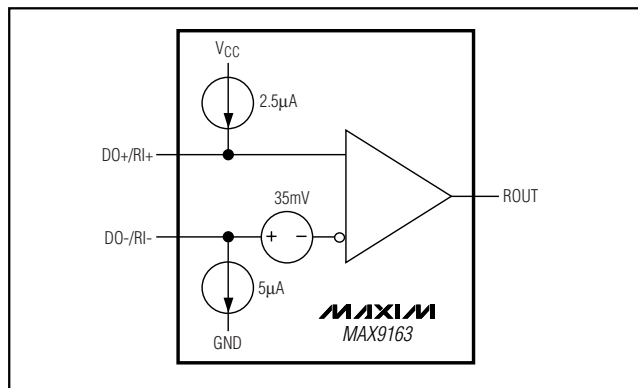

Figure 6. Input Fail-Safe Circuit

In this example, capacitive loading reduces the characteristic impedance from 120Ω to 54Ω . The load seen by a driver located on a card in the middle of the bus is 27Ω because the driver sees two 54Ω terminations in parallel. A typical LVDS driver (rated for a 100Ω load) would not develop a large enough differential signal to be detected reliably by an LVDS receiver.

The MAX9163 BLVDS driver is designed and specified to drive a 27Ω load to differential voltage levels of 180mV to 360mV . A standard LVDS receiver is able to detect this level of differential signal.

Short extensions off the bus, called stubs, contribute to capacitive loading. Keep stubs less than 1in for a good balance between ease of component placement and good signal integrity.

The MAX9163 driver outputs are current-source drivers and drive larger differential signal levels into resistances higher than 27Ω and smaller levels into resistances lower than 27Ω (see the *Typical Operating Characteristics* curves). To keep loading from reducing bus impedance below the rated 27Ω load, PC board traces can be designed for higher unloaded characteristic impedances.

Power-On Reset

The power-on reset voltage of the MAX9163 is typically 2.2V . When the supply falls below this voltage, the device is disabled and the outputs (DO+/RO+, DO-/RO-, and ROUT) are high impedance.

Applications Information

Power-Supply Bypassing

Bypass V_{CC} with high-frequency, surface-mount ceramic $0.1\mu\text{F}$ and $0.001\mu\text{F}$ capacitors in parallel as close to the device as possible, with the smaller valued capacitor closest to V_{CC} .

Termination

In the example in the *Effects of Capacitive Loading* section, the loaded differential impedance of the bus is reduced to 54Ω . Because the bus can be driven from any card position, it must be terminated at each end. A parallel termination of 54Ω at each end of the bus placed across the traces provides a proper termination. The total load seen by the driver is 27Ω .

In a multidrop bus where the driver is at one end and receivers are connected at regular intervals along the bus, the bus has lowered impedance due to capacitive loading. Assuming the same impedance as calculated in the multidrop example (54Ω), the multidrop bus can be terminated with a single, parallel-connected 54Ω resistor at the far end of the driver. Only a single resistor is required because the driver sees one 54Ω differential trace. The signal swings are larger with a 54Ω load. In general, parallel terminate each end of the bus with a resistor matching the differential impedance of the bus (taking into account any reduced impedance due to loading).

Traces, Cables, and Connectors

The characteristics of differential input and output connections affect the performance of the device. Use controlled-impedance traces, cables, and connectors with matched characteristic impedance.

Ensure that noise couples as common mode by running the traces of a differential pair close together. Reduce within-pair skew by matching the electrical length of the conductors within a differential pair. Excessive skew can result in a degradation of magnetic field cancellation.

Maintain the distance between conductors within a differential pair to avoid discontinuities in differential impedance. Minimize the number of vias to further prevent impedance discontinuities.

Board Layout

For BLVDS applications, a four-layer PC board with separate power, ground, BLVDS, LVDS, and logic signal layers is recommended. Separate the LVTTTL/LVCMOS and BLVDS signals to prevent coupling.

Bus LVDS 3.3V Single Transceiver

Typical Application Circuit

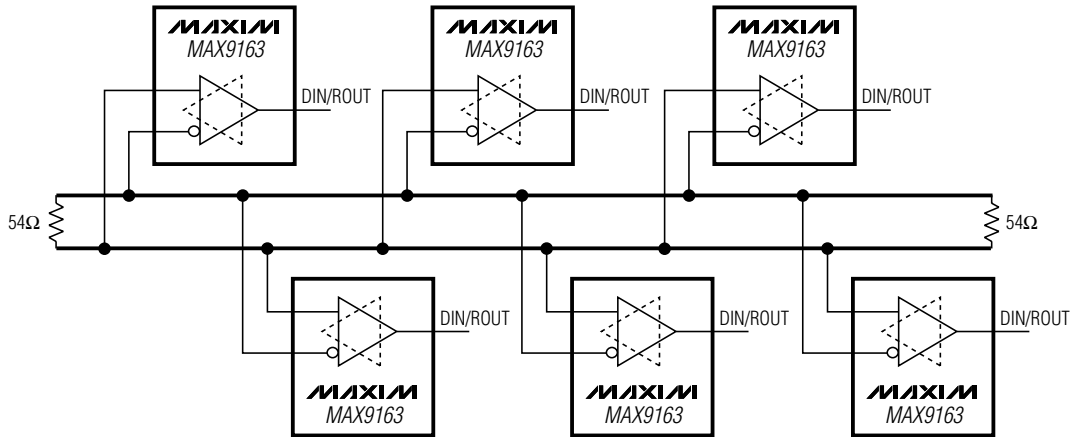

TABLE 1. FUNCTION SELECT

DE	RE	MODE SELECTED
H	H	Driver
L	L	Receiver
L	H	High impedance
H	L	Loopback

TABLE 2. DRIVER MODE

DE	INPUTS		OUTPUTS	
	DIN	DO+/RI+	DO-/RI-	
H	L ($\leq 0.8V$)	L	H	
H	H ($\geq 2.0V$)	H	L	
H	($> 0.8mV$ and $< 2.0mV$)	Undefined	Undefined	
L	X	Z	Z	

X: High or low
Z: High impedance

TABLE 3. RECEIVER MODE

RE	INPUTS		OUTPUT
	(DO+/RI+) - (DO-/RI-)	ROUT	
L	L ($\leq -100mV$)	L	L
L	H ($\geq 100mV$)	H	H
L	($> -100mV$ and $< 100mV$)		Undefined
L	Undriven and open, shorted, or terminated		H
H	X		Z

DE: Low
X: High or low
Z: High impedance

Chip Information

TRANSISTOR COUNT: 901

PROCESS: CMOS

Bus LVDS 3.3V Single Transceiver

Package Information

(The package drawing(s) in this data sheet may not reflect the most current specifications. For the latest package outline information, go to www.maxim-ic.com/packages.)

MAX9163

SOICN .EPS

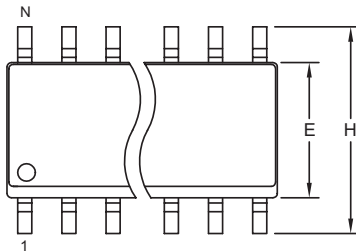

TOP VIEW

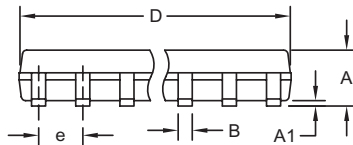

FRONT VIEW

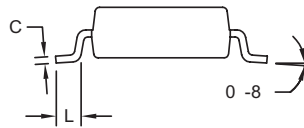

SIDE VIEW

DIM	INCHES		MILLIMETERS	
	MIN	MAX	MIN	MAX
A	0.053	0.069	1.35	1.75
A1	0.004	0.010	0.10	0.25
B	0.014	0.019	0.35	0.49
C	0.007	0.010	0.19	0.25
e	0.050 BSC		1.27 BSC	
E	0.150	0.157	3.80	4.00
H	0.228	0.244	5.80	6.20
L	0.016	0.050	0.40	1.27

VARIATIONS:

DIM	INCHES		MILLIMETERS		N	MS012
	MIN	MAX	MIN	MAX		
D	0.189	0.197	4.80	5.00	8	AA
D	0.337	0.344	8.55	8.75	14	AB
D	0.386	0.394	9.80	10.00	16	AC

NOTES:

1. D&E DO NOT INCLUDE MOLD FLASH.
2. MOLD FLASH OR PROTRUSIONS NOT TO EXCEED 0.15mm (.006").
3. LEADS TO BE COPLANAR WITHIN 0.10mm (.004").
4. CONTROLLING DIMENSION: MILLIMETERS.
5. MEETS JEDEC MS012.
6. N = NUMBER OF PINS.

<small>PROPRIETARY INFORMATION</small>	
TITLE: PACKAGE OUTLINE, .150" SOIC	
APPROVAL:	DOCUMENT CONTROL NO. 21-0041
REV. B	1/1

Maxim cannot assume responsibility for use of any circuitry other than circuitry entirely embodied in a Maxim product. No circuit patent licenses are implied. Maxim reserves the right to change the circuitry and specifications without notice at any time.

Maxim Integrated Products, 120 San Gabriel Drive, Sunnyvale, CA 94086 408-737-7600 _____ **11**

Looking for pricing, stock, or lifecycle information?

Click below to explore more details on WIN SOURCE:

 [View MAX9163ESA+ on WIN SOURCE](#)

 [Maxim Integrated](#) Information

Optimize Your Supply Chain with WIN SOURCE Solutions

-  Global Sourcing Solution
-  Obsolete Management
-  Cost Control Management
-  Shortage Management
-  Alternative Solution
-  Excess Inventory Management