



**THE DATASHEET OF
MAX7448EUD+T**



EVALUATION KIT
AVAILABLE

MAXIM

4-Channel RGB Video Filter with Asynchronous CVBS Input

MAX7448

General Description

The MAX7448, 4-channel, buffered video reconstruction filter is ideal for anti-aliasing and digital-to-analog converter (DAC)-smoothing video applications or whenever analog video is reconstructed from a digital data stream (such as cable/satellite/terrestrial set-top boxes, DVD players, hard-disk recorders (HDRs), and personal video recorders (PVRs)). This device operates from a single +5V supply and has a flat passband out to 5MHz with a stopband attenuation of 43dB at 27MHz. This makes it ideal for use with NTSC, PAL, and standard-definition digital TV (SDTV) video systems. Each output is capable of driving two standard 150Ω video loads.

The MAX7448 processes RGB and asynchronous CVBS video signals. The output video buffers have a fixed gain of +6dB. The channel used for CVBS video has high-frequency boost circuitry, which provides picture sharpness with +1.2dB of gain boost without degradation in the stopband. The output video drivers can be disabled with an external pin.

The MAX7448 is available in a 14-pin TSSOP package with an exposed pad, and is specified over the -40°C to +85°C extended temperature range.

Applications

Set-Top Boxes/HDRs DVD Players
Game Consoles Digital VCRs
Desktop Video Editors

Features

- ◆ 4-Channel Filter and Buffer for RGB and CVBS Video Signals
- ◆ Filter Response Ideal for NTSC, PAL, and Interlaced SDTV Video Signals
- ◆ 43dB (typ) Stopband Attenuation at 27MHz
- ◆ ±0.75dB (max) Passband Ripple Out to 5MHz
- ◆ Blanking Level Voltage on Cable <1V
- ◆ Each Channel Drives Two 150Ω Video Loads
- ◆ +5V Single-Supply Voltage
- ◆ Small 14-Pin TSSOP Package

Ordering Information

PART	TEMP RANGE	PIN-PACKAGE	PACKAGE CODE
MAX7448EUD	-40°C to +85°C	14 TSSOP-EP*	U14E-3

*EP = Exposed pad.

Pin Configuration appears at end of data sheet.

Functional Diagram

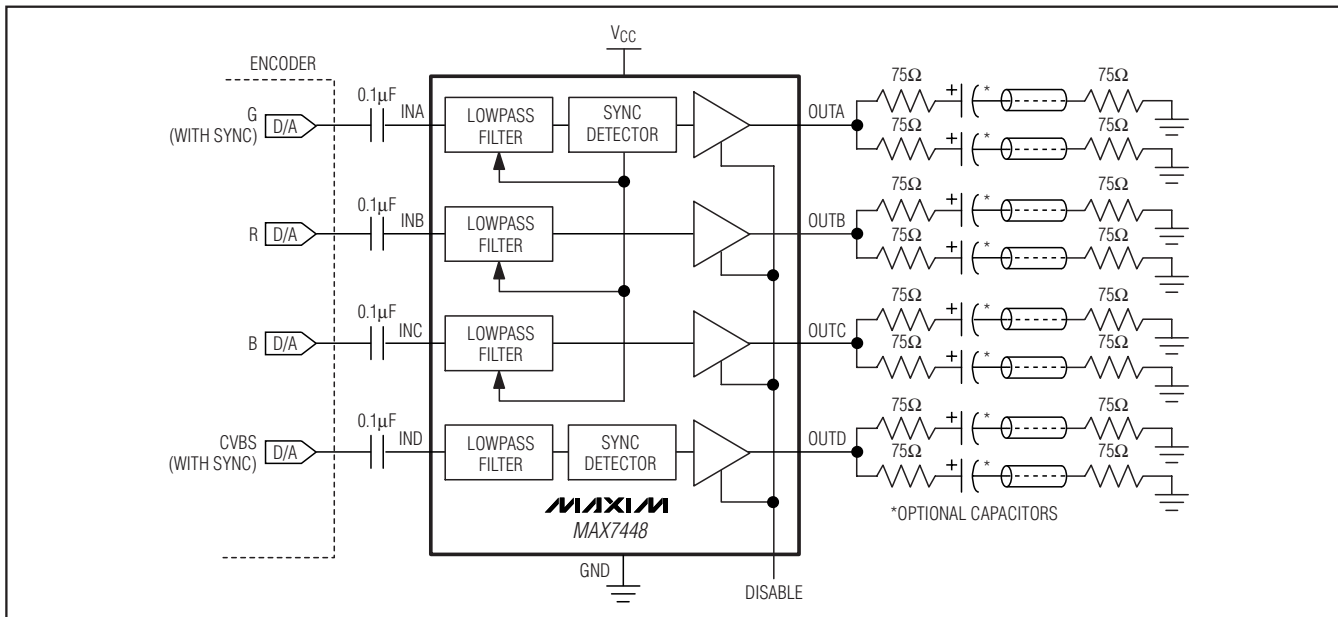

MAXIM

Maxim Integrated Products 1

For pricing, delivery, and ordering information, please contact Maxim/Dallas Direct! at 1-888-629-4642, or visit Maxim's website at www.maxim-ic.com.

4-Channel RGB Video Filter with Asynchronous CVBS Input

ABSOLUTE MAXIMUM RATINGS

V_{CC} to GND+6V
 All Other Pins to GND-0.3V to (V_{CC} + 0.3V)
 Maximum Current into Any Pin Except V_{CC} and GND±50mA
 Continuous Power Dissipation (T_A = +70°C)
 TSSOP-EP (derate 20.8mW/°C above +70°C).....1667mW

Operating Temperature Range-40°C to +85°C
 Storage Temperature Range-65°C to +150°C
 Junction Temperature+150°C
 Lead Temperature (soldering, 10s)+300°C

Stresses beyond those listed under "Absolute Maximum Ratings" may cause permanent damage to the device. These are stress ratings only, and functional operation of the device at these or any other conditions beyond those indicated in the operational sections of the specifications is not implied. Exposure to absolute maximum rating conditions for extended periods may affect device reliability.

ELECTRICAL CHARACTERISTICS

(V_{CC} = +5V ±5%, C_L = 0 to 20pF, R_L = 75Ω to GND for DC-coupled load, R_L = 75Ω to V_{CC} / 2 for AC-coupled load, C_{IN} = 0.1μF, GAIN = +6dB, T_A = T_{MIN} to T_{MAX}, unless otherwise noted. Typical values are at V_{CC} = +5V, T_A = +25°C.)

PARAMETER	SYMBOL	CONDITIONS	MIN	TYP	MAX	UNITS	
Passband Response		f = 100kHz to 5MHz, relative to 100kHz	Channels A, B, C	+0.75	+0.15	+0.75	dB
			Channel D	+0.9	+1.2	+1.5	
Stopband Attenuation	A _{SB}	f ≥ 27MHz	39	43		dB	
Differential Gain	dG	5-step modulated staircase		0.15	0.50	%	
Differential Phase	dθ	5-step modulated staircase		0.15	0.50	Degrees	
Signal-to-Noise Ratio	SNR	Peak signal (2V _{P-P}) to RMS noise, f = 100Hz to 50MHz		80		dB	
Group Delay Deviation	Δt _g	Deviation from 100kHz to 4.1MHz	Channels A, B, C	11	20	ns	
			Channel D	17	30		
Line-Time Distortion	H _{DIST}	18μs, 100 IRE bar			0.3	%	
Field-Time Distortion	V _{DIST}	130 lines, 18μs, 100 IRE bar			0.5	%	
Clamp Settling Time	t _{CLAMP}	To ±1%		430		Lines	
Output DC Clamp Level		Channels A, D	0.6	0.9	1.1	V	
		Channels B, C	1.1	1.5	1.8		
Low-Frequency Gain Accuracy	A _V	f = 100kHz	-3		+3	%	
Low-Frequency Gain Matching	A _{V(MATCH)}	Low-frequency channel-to-channel matching, f = 100kHz			4	%	
Group Delay Matching	t _{g(MATCH)}	Low-frequency channel-to-channel matching, f = 100kHz		2		ns	
Channel-to-Channel Crosstalk	X _{TALK}	f = 100kHz to 3.58MHz		60		dB	
Output Short-Circuit Current	I _{SC}	OUT_ shorted to GND or V _{CC}		70		mA	
Input Leakage Current	I _{IN}				10	μA	
Input Dynamic Swing		Channels A, D			1.2	V _{P-P}	
		Channels B, C			0.9		
SUPPLY							
Supply Voltage Range	V _{CC}		4.75		5.25	V	
Supply Current	I _{CC}	No load		100	140	mA	
Power-Supply Rejection Ratio	PSRR	V _{IN} = 100mV _{P-P} , f = 0 to 3.5MHz		40		dB	

4-Channel RGB Video Filter with Asynchronous CVBS Input

ELECTRICAL CHARACTERISTICS (continued)

($V_{CC} = +5V \pm 5\%$, $C_L = 0$ to $20pF$, $R_L = 75\Omega$ to GND for DC-coupled load, $R_L = 75\Omega$ to $V_{CC} / 2$ for AC-coupled load, $C_{IN_} = 0.1\mu F$, $GAIN = +6dB$, $T_A = T_{MIN}$ to T_{MAX} , unless otherwise noted. Typical values are at $V_{CC} = +5V$, $T_A = +25^\circ C$.)

PARAMETER	SYMBOL	CONDITIONS	MIN	TYP	MAX	UNITS
DISABLE						
Output Impedance during Disable	$Z_{DISABLE}$	At 5MHz		2		k Ω
Disable Logic-Input High Voltage	V_{IH}		2.0			V
Disable Logic-Input Low Voltage	V_{IL}				0.8	V
Disable Logic-Input Current	$I_{DISABLE}$	$V_{IL} = 0V$ (sink), $V_{IH} = V_{CC}$ (source)			± 10	μA

Typical Operating Characteristics

($V_{CC} = +5V$, $T_A = +25^\circ C$, unless otherwise noted.)

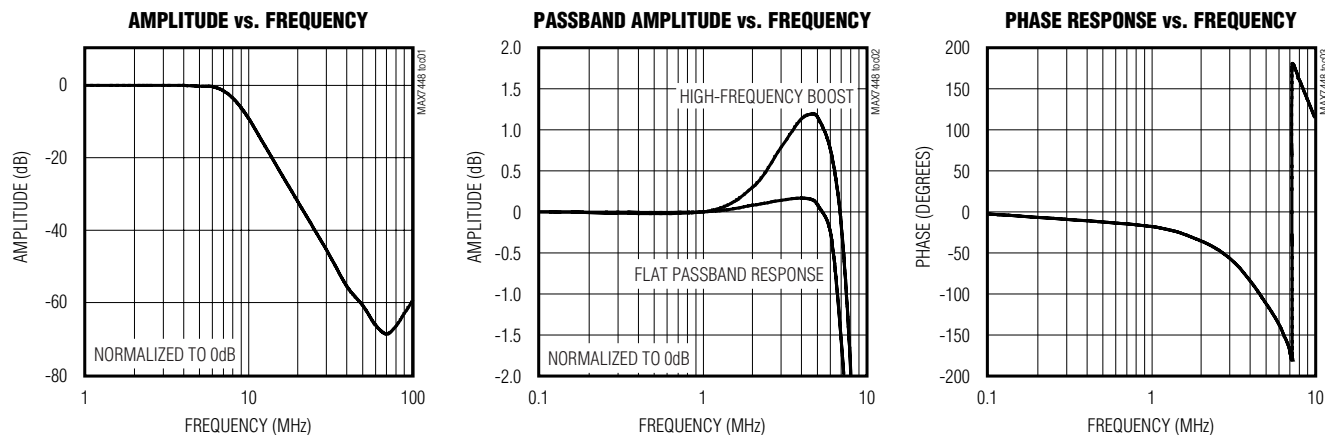

4-Channel RGB Video Filter with Asynchronous CVBS Input

Typical Operating Characteristics (continued)

(V_{CC} = +5V, T_A = +25°C, unless otherwise noted.)

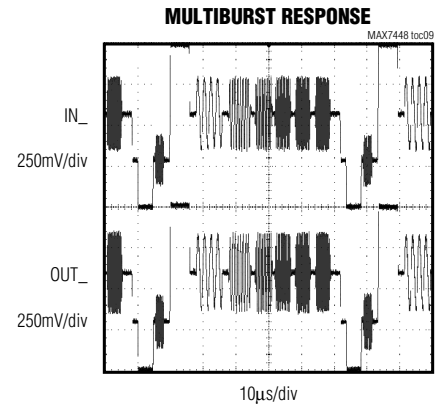
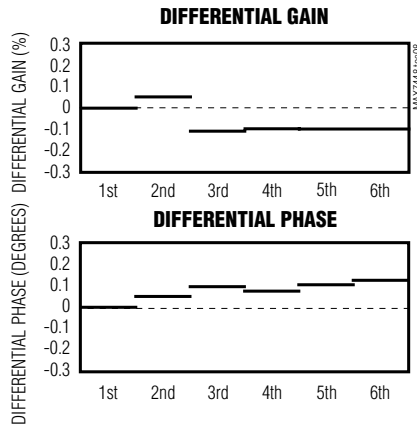
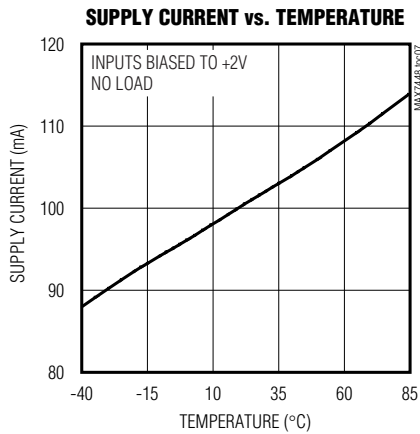
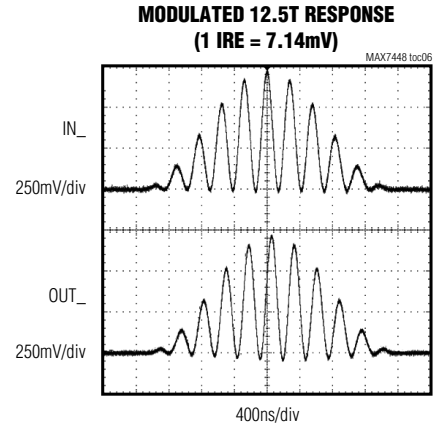
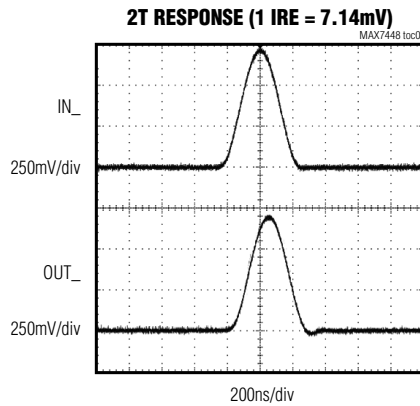
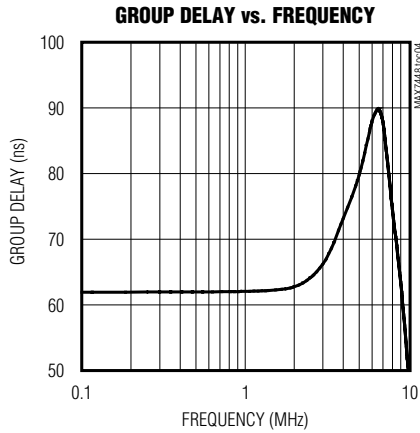

4-Channel RGB Video Filter with Asynchronous CVBS Input

MAX7448

Pin Description

PIN	NAME	FUNCTION
1	INA	Channel A Video Input. Use channel A for the green (G with sync) video signal. AC-couple INA with a series 0.1 μ F capacitor.
2	INB	Channel B Video Input. Use channel B for the red (R) video signal. AC-couple INB with a series 0.1 μ F capacitor.
3	INC	Channel C Video Input. Use channel C for the blue (B) video signal. AC-couple INC with a series 0.1 μ F capacitor.
4	IND	Channel D Video Input. Use channel D for a CVBS (with sync) signal. AC-couple IND with a series 0.1 μ F capacitor.
5	DISABLE	Disable Logic Input. A logic-low on DISABLE enables the output buffers. A logic-high on DISABLE disables all buffer outputs and puts them in a high-impedance state.
6–9	GND	Ground
10	V _{CC}	+5V Supply Input
11	OUTD	Channel D Buffer Output. This output can be either AC- or DC-coupled.
12	OUTC	Channel C Buffer Output. This output can be either AC- or DC-coupled.

Detailed Description

The MAX7448 filters and buffers video-encoder DAC outputs in applications such as set-top boxes, HDRs, DVD players, and digital VCRs. The MAX7448 reconstructs and cleans up analog video signals from the output of DAC video encoders. Each channel consists of a lowpass filter and an output video buffer that can drive two standard 150 Ω video loads.

The MAX7448 is designed to process R, G (with sync), B, and CVBS_{ASYNC} video signals. The video signal processed by channel A (G video signal) requires a sync pulse. This sync pulse provides the required timing for channels A, B, and C. Channel D allows an asynchronous video signal to be processed with its own local sync separator.

This device operates from a single +5V supply and has a nominal cutoff frequency of 5MHz optimized for NTSC, PAL, and SDTV.

Filter

Filter Response

The reconstruction filter consists of two 2nd-order Sallen-Key stages. The Butterworth-type response features a maximally flat passband for NTSC and PAL bandwidths. The stopband offers at least 43dB (typ) of attenuation at a video-encoder DAC sampling frequency of 27MHz (see the *Typical Operating Characteristics*).

High-Frequency Boost

The +1.2dB high-frequency boost on channel D (CVBS video signal) increases image sharpness by compensating for signal degradation and rolloff in the video encoder. Channels A, B, and C do not boost high-frequency signals and have a flat response over the video bandwidth.

Output Buffers

Each output buffer has a fixed gain of +6dB and can drive two 150 Ω video loads with a 2V_{p-p} signal. The MAX7448 can drive an AC load or drive the video load directly without using a large output capacitor. The output buffers drive DC loads with an output blanking level of less than 1V.

4-Channel RGB Video Filter with Asynchronous CVBS Input

Output Clamp Level

When a sync pulse is detected on channel A, the DC restore loop is activated for channel A, B, and C. Channel D's DC restore loop is activated by the sync pulse on channel D. The function of the loop is to set the DC level of the video signal to the specified level of the signal type (R, G, B, CVBS). See Table 1 for clamp levels and sync sources.

Table 1. Output Clamp Level and Sync Source

CHANNEL	CLAMP LEVEL (V)	SYNC SOURCE
A	0.9	Channel A
B	1.5	Channel A
C	1.5	Channel A
D	0.9	Channel D

Applications Information

Input Considerations

Use 0.1 μ F ceramic capacitors to AC-couple the inputs. These input capacitors store a DC level so the outputs are clamped to an appropriate DC voltage level.

Output Considerations

The outputs are typically connected to a 75 Ω series back-match resistor followed by the video cable. Because of the inherent divide-by-two of this configuration, the voltage on the video cable is always less than 1V, complying with industry-standard video requirements such as the European SCART standard (which allows up to 2V of DC on the video cable). The video buffer can also drive an AC-coupled video load. Good video performance is achieved with an output capacitor as low as 220 μ F.

Power-Supply Bypassing and Layout

The MAX7448 operates from a single +5V supply. Bypass V_{CC} to GND with a 0.1 μ F capacitor. Place all external components as close to the device as possible.

Exposed Pads

The TSSOP-EP package has an exposed pad on the bottom of the package. This pad is electrically connected to GND and should be connected to the ground plane for improved thermal conductivity. Do not route signals under this package.

Pin Configuration

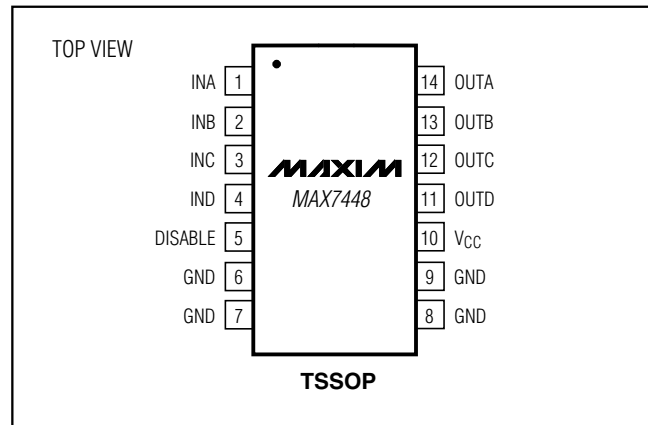

Chip Information

TRANSISTOR COUNT: 6300

PROCESS: BiCMOS

4-Channel RGB Video Filter with Asynchronous CVBS Input

Package Information

(The package drawing(s) in this data sheet may not reflect the most current specifications. For the latest package outline information, go to www.maxim-ic.com/packages.)

MAX7448

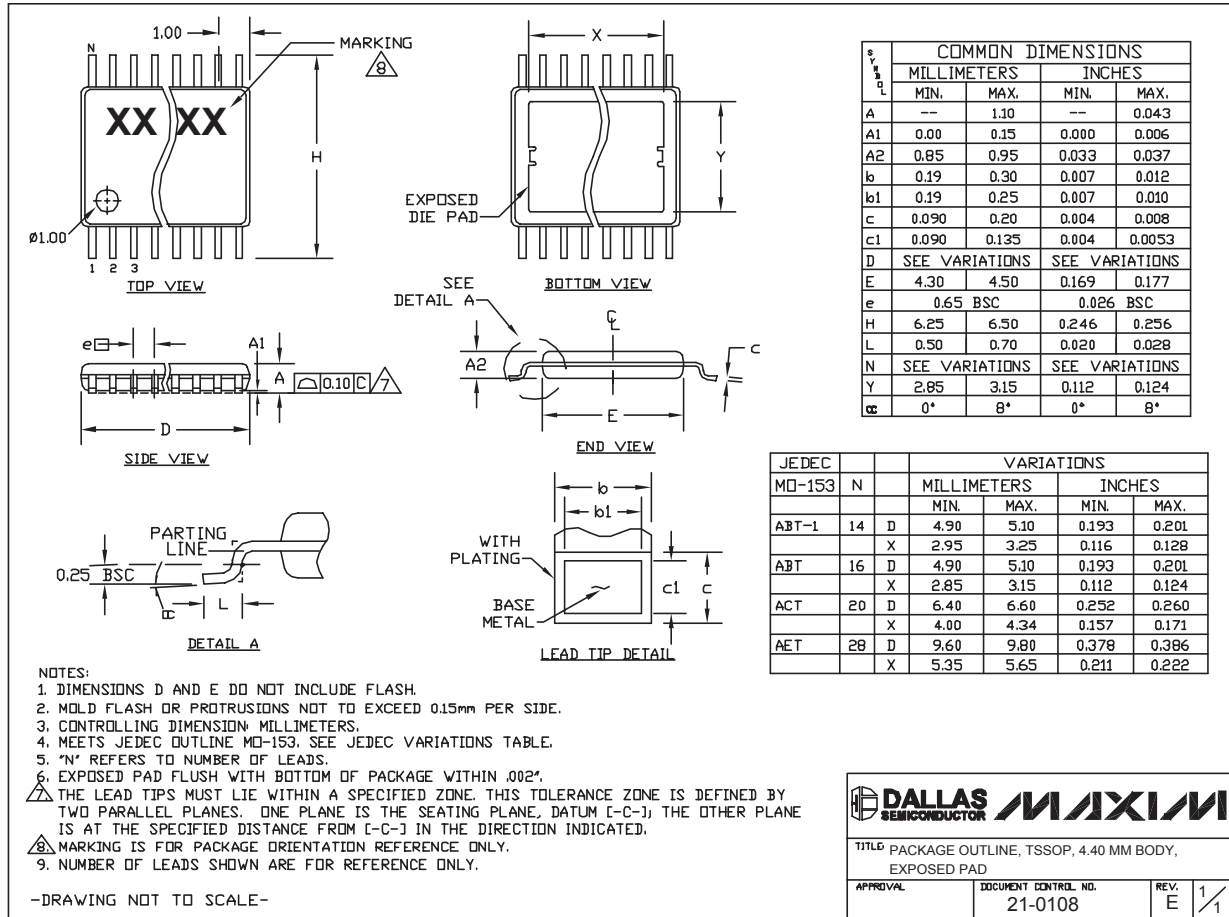

Maxim cannot assume responsibility for use of any circuitry other than circuitry entirely embodied in a Maxim product. No circuit patent licenses are implied. Maxim reserves the right to change the circuitry and specifications without notice at any time.

Maxim Integrated Products, 120 San Gabriel Drive, Sunnyvale, CA 94086 408-737-7600 7

Looking for pricing, stock, or lifecycle information?

Click below to explore more details on WIN SOURCE:

- ⊖ [View MAX7448EUD+T on WIN SOURCE](#)
- ⊖ [Maxim Integrated Information](#)

Optimize Your Supply Chain with WIN SOURCE Solutions

- ✓ Global Sourcing Solution
- ✓ Obsolete Management
- ✓ Cost Control Management
- ✓ Shortage Management
- ✓ Alternative Solution
- ✓ Excess Inventory Management