



**THE DATASHEET OF  
MAX6342SUT+T**





# 6-Pin $\mu$ P Reset Circuit with Power-Fail Comparator

**MAX6342-MAX6345**

## General Description

The MAX6342-MAX6345 family of microprocessor ( $\mu$ P) supervisory circuits monitors power supplies in digital systems. These devices significantly improve system reliability and accuracy compared to separate ICs or discrete components.

The MAX6342-MAX6345 provide factory-trimmed  $V_{CC}$  reset threshold voltages from 2.33V to 4.63V and operate with supply voltages between +1V and +5.5V. A +1.25V threshold detector allows for a power-fail warning, for low-battery detection, or for monitoring another power supply. The MAX6342 contains an  $\overline{MR}$  input and an active-low push-pull reset. The MAX6343 and MAX6344 are identical to the MAX6342 except they provide an active-low, open-drain reset and an active-high, push-pull reset, respectively. The MAX6345 provides a second reset output in place of the  $\overline{MR}$  input to give it an active-high push-pull reset and an active-low push-pull reset.

All of the devices are packaged in a miniature 6-pin SOT23.

## Applications

Portable Computers  
Telecom Equipment  
Networking Equipment  
Portable/Battery-Powered Equipment  
Multivoltage Systems  
Embedded Control Systems

Typical Operating Circuit appears at end of data sheet.

## Selector Guide 1

SUFFIX	RESET THRESHOLD (V)
L	4.63
M	4.38
T	3.08
S	2.93
R	2.63
Z	2.33

## Features

- ◆ Small 6-Pin SOT23 Package
- ◆ Precision Factory-Set  $V_{CC}$  Reset Thresholds Between 2.33V and 4.63V
- ◆ Guaranteed  $\overline{RESET}$  Valid to  $V_{CC} = +1V$
- ◆ 100ms min Reset Pulse Width
- ◆ Debounced CMOS-Compatible Manual-Reset Input
- ◆ Voltage Monitor for Power-Fail or Low-Battery Warning

## Ordering Information

PART	TEMP RANGE	PIN-PACKAGE
MAX6342_UT-T	-40°C to +125°C	6 SOT23-6
MAX6343_UT-T	-40°C to +125°C	6 SOT23-6
MAX6344_UT-T	-40°C to +125°C	6 SOT23-6
MAX6345_UT-T	-40°C to +125°C	6 SOT23-6

**Note:** The MAX6342-MAX6345 are available with factory-set reset thresholds from 2.33V to 4.63V (see Selector Guides 1, 2). Insert the letter corresponding to the desired nominal reset threshold into the blank following the part number. There is a 2500 piece order increment required for the SOT package. SOT Top Marks table appears at end of data sheet.

Devices are available in both leaded and lead-free packaging. Specify lead-free by replacing "-T" with "+T" when ordering.

## Pin Configurations

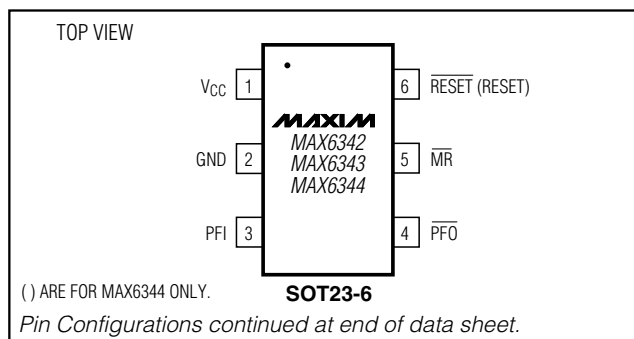

## Selector Guide 2

PART	PUSH-PULL $\overline{RESET}$ OUTPUT	OPEN-DRAIN $\overline{RESET}$ OUTPUT	PUSH-PULL RESET OUTPUT	MANUAL-RESET INPUT
MAX6342	✓	—	—	✓
MAX6343	—	✓	—	✓
MAX6344	—	—	✓	✓
MAX6345	✓	—	✓	—



# 6-Pin $\mu$ P Reset Circuit with Power-Fail Comparator

## ABSOLUTE MAXIMUM RATINGS

V <sub>CC</sub> to GND	.....-0.3V to +6V
RESET, $\overline{\text{RESET}}$	.....-0.3V to (V <sub>CC</sub> + 0.3V)
(MAX6342/MAX6344/MAX6345)	.....-0.3V to (V <sub>CC</sub> + 0.3V)
RESET (MAX6343)	.....-0.3V to +6V
MR, PFI, PFO	.....-0.3V to (V <sub>CC</sub> + 0.3V)
Input Current, V <sub>CC</sub>	.....50mA
Output Current, RESET, $\overline{\text{RESET}}$	.....50mA

Continuous Power Dissipation (T <sub>A</sub> = +70°C)	.....320mW
6-Pin SOT23 (derate 4mW/°C above +70°C)	.....320mW
Operating Temperature Range	.....-40°C to +125°C
Junction Temperature	.....+150°C
Storage Temperature Range	.....-65°C to +150°C
Lead Temperature Range (soldering, 10s)	.....+300°C

Stresses beyond those listed under "Absolute Maximum Ratings" may cause permanent damage to the device. These are stress ratings only, and functional operation of the device at these or any other conditions beyond those indicated in the operational sections of the specifications is not implied. Exposure to absolute maximum rating conditions for extended periods may affect device reliability.

## ELECTRICAL CHARACTERISTICS

(V<sub>CC</sub> = +1.0V to +5.5V, T<sub>A</sub> = -40°C to +125°C, unless otherwise noted. Typical values are at T<sub>A</sub> = +25°C and V<sub>CC</sub> = +3V.) (Note 1)

PARAMETER	SYMBOL	CONDITIONS		MIN	TYP	MAX	UNITS
Supply Voltage Range	V <sub>CC</sub>	T <sub>A</sub> = 0°C to +70°C		1.0		5.5	V
		T <sub>A</sub> = -40°C to +125°C		1.2		5.5	
Supply Current	I <sub>CC</sub>	No load	V <sub>CC</sub> = 3V, T <sub>A</sub> = -40° to +85°C		25	40	$\mu$ A
			V <sub>CC</sub> = 5.5V, T <sub>A</sub> = -40° to +85°C		30	50	
			V <sub>CC</sub> = 3V, T <sub>A</sub> = -40° to +125°C		25	50	
			V <sub>CC</sub> = 5.5V, T <sub>A</sub> = -40° to +125°C		30	60	
Reset Threshold	V <sub>TH</sub>	MAX634_L	T <sub>A</sub> = +25°C	4.56	4.63	4.70	V
			T <sub>A</sub> = -40°C to +85°C	4.50		4.75	
			T <sub>A</sub> = -40°C to +125°C	4.40		4.86	
		MAX634_M	T <sub>A</sub> = +25°C	4.31	4.38	4.45	
			T <sub>A</sub> = -40°C to +85°C	4.25		4.50	
			T <sub>A</sub> = -40°C to +125°C	4.16		4.56	
		MAX634_T	T <sub>A</sub> = +25°C	3.03	3.08	3.13	
			T <sub>A</sub> = -40°C to +85°C	3.00		3.15	
			T <sub>A</sub> = -40°C to +125°C	2.92		3.23	
		MAX634_S	T <sub>A</sub> = +25°C	2.89	2.93	2.97	
			T <sub>A</sub> = -40°C to +85°C	2.85		3.00	
			T <sub>A</sub> = -40°C to +125°C	2.78		3.08	
		MAX634_R	T <sub>A</sub> = +25°C	2.59	2.63	2.67	
			T <sub>A</sub> = -40°C to +85°C	2.55		2.70	
			T <sub>A</sub> = -40°C to +125°C	2.50		2.76	
		MAX634_Z	T <sub>A</sub> = +25°C	2.30	2.33	2.36	
T <sub>A</sub> = -40°C to +85°C	2.25			2.38			
T <sub>A</sub> = -40°C to +125°C	2.21			2.45			
V <sub>CC</sub> to Reset Delay		V <sub>CC</sub> = V <sub>TH</sub> to (V <sub>TH</sub> - 100mV)			20		$\mu$ s
$\overline{\text{RESET}}$ and RESET Outputs Drive Capability (Note 2)	V <sub>OL</sub>	V <sub>CC</sub> > 1.2V, I <sub>SINK</sub> = 100 $\mu$ A				0.4	V
		V <sub>CC</sub> > 2.7V, I <sub>SINK</sub> = 1.2mA				0.3	
		V <sub>CC</sub> > 4.5V, I <sub>SINK</sub> = 3.2mA				0.4	
	V <sub>OH</sub>	V <sub>CC</sub> > 1.2V, I <sub>SOURCE</sub> = 50 $\mu$ A		0.8 $\times$ V <sub>CC</sub>			V
		V <sub>CC</sub> > 2.7V, I <sub>SOURCE</sub> = 500 $\mu$ A (MAX6342/MAX6345 only)		0.8 $\times$ V <sub>CC</sub>			
		V <sub>CC</sub> > 4.5V, I <sub>SOURCE</sub> = 800 $\mu$ A (MAX6342/MAX6345 only)		0.8 $\times$ V <sub>CC</sub>			

# 6-Pin $\mu$ P Reset Circuit with Power-Fail Comparator

## ELECTRICAL CHARACTERISTICS (continued)

( $V_{CC} = +1.0V$  to  $+5.5V$ ,  $T_A = -40^{\circ}C$  to  $+125^{\circ}C$ , unless otherwise noted. Typical values are at  $T_A = +25^{\circ}C$  and  $V_{CC} = +3V$ .) (Note 1)

PARAMETER	SYMBOL	CONDITIONS	MIN	TYP	MAX	UNITS
Reset Timeout Period	$t_{RP}$	$T_A = -40^{\circ}C$ to $+85^{\circ}C$	100	180	280	ms
		$T_A = -40^{\circ}C$ to $+125^{\circ}C$	80		360	
Open-Drain $\overline{RESET}$ Output Leakage Current (Note 3)	$I_{LKG}$	MAX6343 only, $V_{CC} > V_{TH(MAX)}$			1	$\mu A$
$\overline{MR}$ Input Low	$V_{IL}$				$0.3 \times V_{CC}$	V
$\overline{MR}$ Input High	$V_{IH}$		$0.7 \times V_{CC}$			V
$\overline{MR}$ Pull-Up Resistance			60			$k\Omega$
$\overline{MR}$ Minimum Pulse Width			1			$\mu s$
$\overline{MR}$ Glitch Rejection				0.1		$\mu s$
$\overline{MR}$ to Reset Delay				0.2		$\mu s$
PFI Input Threshold		$T_A = -40^{\circ}C$ to $+85^{\circ}C$	1.2	1.25	1.3	V
		$T_A = -40^{\circ}C$ to $+125^{\circ}C$	1.15		1.35	
PFI Leakage Current (Note 3)		$T_A = -40^{\circ}C$ to $+85^{\circ}C$		$\pm 0.01$	$\pm 25$	nA
		$T_A = -85^{\circ}C$ to $+125^{\circ}C$			$\pm 100$	
$\overline{PFO}$ Output Voltage	$V_{OL}$	$V_{CC} = 4.5V$ , $I_{SINK} = 3.2mA$			0.4	V
$\overline{PFO}$ Output Voltage	$V_{OH}$	$V_{CC} = 4.5V$ , $I_{SOURCE} = 800\mu A$	$0.8 \times V_{CC}$			V
$\overline{PFO}$ Output Short-Circuit Current		Output sink current		20		mA
		Output source current		5		
PFI to $\overline{PFO}$ Delay		$V_{OVERDRIVE} = 15mV$		3		$\mu s$

**Note 1:** Overtemperature limits are guaranteed by design and not production tested.

**Note 2:** Apply to each part in accordance with threshold voltage, output configuration, and manual reset status selected.

**Note 3:** Leakage parameters are guaranteed by design and not production tested.

## Typical Operating Characteristics

( $V_{PFI} = V_{CC} = +5V$ ,  $T_A = +25^{\circ}C$ , unless otherwise noted.)

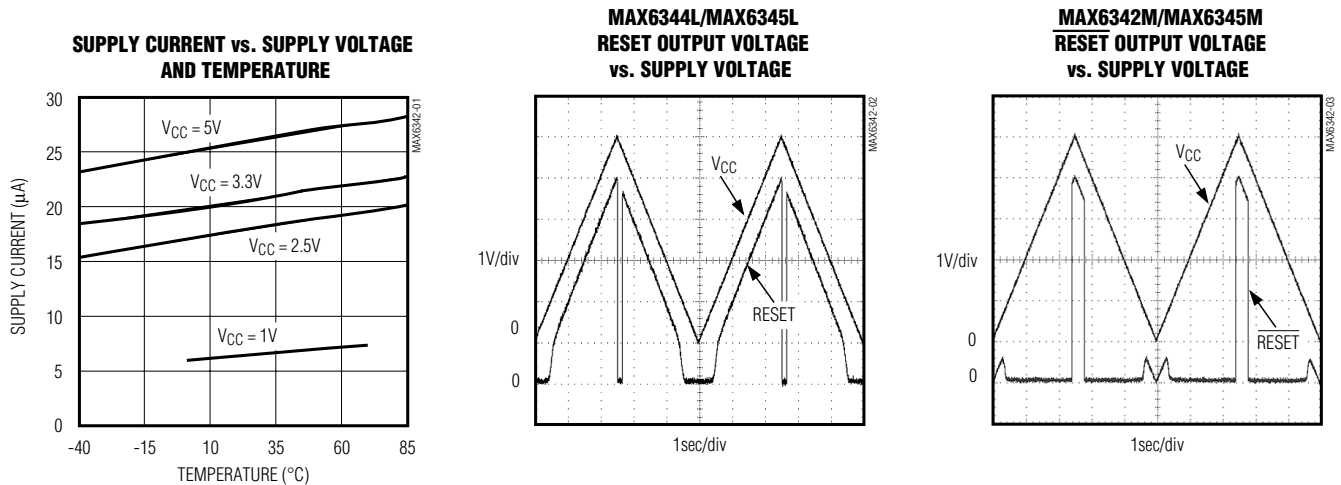

# 6-Pin $\mu$ P Reset Circuit with Power-Fail Comparator

## Typical Operating Characteristics (continued)

( $V_{PFI} = V_{CC} = +5V$ ,  $T_A = +25^\circ C$ , unless otherwise noted.)

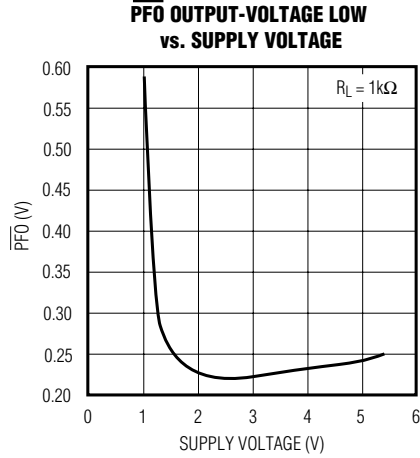
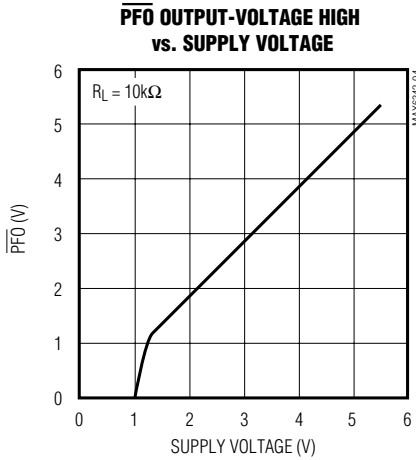

**MAX6344/MAX6345  
RESET RESPONSE TIME**

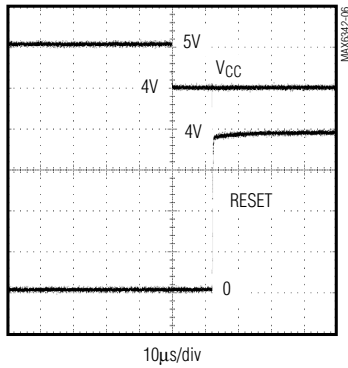

**MAX6342/MAX6345  
RESET RESPONSE TIME**

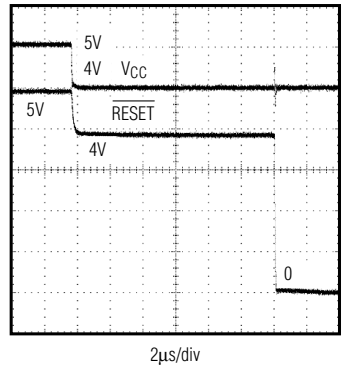

## Pin Description

PIN				NAME	FUNCTION
MAX6342	MAX6343	MAX6344	MAX6345		
1	1	1	1	$V_{CC}$	Supply Voltage
2	2	2	2	GND	Ground
3	3	3	3	PFI	Power-Fail Voltage Monitor Input. When PFI is $< 1.25V$ , $\overline{PFO}$ goes low. Connect PFI to GND or $V_{CC}$ when not used.
4	4	4	4	$\overline{PFO}$	Power-Fail Voltage Monitor Output

# 6-Pin $\mu\text{P}$ Reset Circuit with Power-Fail Comparator

## Pin Description (continued)

PIN				NAME	FUNCTION
MAX6342	MAX6343	MAX6344	MAX6345		
5	5	5	—	$\overline{\text{MR}}$	Manual-Reset Input. Pull low to force a reset. $\overline{\text{RESET}}$ or RESET remains active as long as $\overline{\text{MR}}$ is low and for the reset timeout period after $\overline{\text{MR}}$ goes high. Leave unconnected or connect to $V_{\text{CC}}$ if unused.
6	6	—	5	$\overline{\text{RESET}}$	Active-Low Reset Output. Push-pull for MAX6342/MAX6345. Open-drain for MAX6343. It remains low for 180ms after $V_{\text{CC}}$ rises above the reset threshold or $\overline{\text{MR}}$ goes from low to high.
—	—	6	6	RESET	Active-High Push-Pull Reset Output. It remains high for 180ms after $V_{\text{CC}}$ rises above the reset threshold or $\overline{\text{MR}}$ goes from low to high.

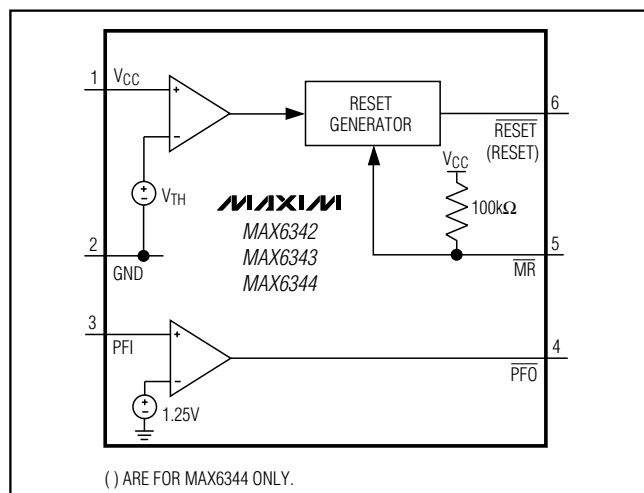

Figure 1. MAX6342/MAX6343/MAX6344 Functional Diagram

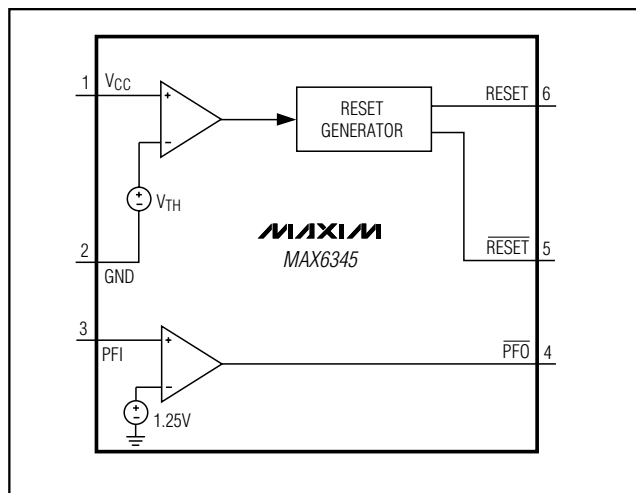

Figure 2. MAX6345 Functional Diagram

## Detailed Description

### Reset Output

A  $\mu\text{P}$ 's reset input starts the  $\mu\text{P}$  in a known state. These  $\mu\text{P}$  supervisory circuits assert reset to prevent code-execution errors during power-up, power-down, or brownout conditions.

$\overline{\text{RESET}}$  and RESET are guaranteed to be asserted at a valid logic level for  $V_{\text{CC}} > +1\text{V}$  (see the *Electrical Characteristics* table). Once RESET asserts, it remains asserted for at least 100ms ( $t_{\text{RP}}$ ) after  $V_{\text{CC}}$  rises above its threshold value or after  $\overline{\text{MR}}$  returns high (Figures 1 and 2).

### Open-Drain $\overline{\text{RESET}}$ Output

The MAX6343 has an active-low, open-drain reset output. This output sinks current when  $\overline{\text{RESET}}$  is asserted. Connect a pull-up resistor from  $\overline{\text{RESET}}$  to any positive supply voltage up to +5.5V (Figure 3). Select a resistor value large enough to register a logic low (see the *Electrical Characteristics* table), and small enough to register a logic high while supplying all input current and leakage paths connected to the  $\overline{\text{RESET}}$  line. A 10k $\Omega$  pull-up is sufficient in most applications.

### Manual Reset

The MAX6342/MAX6343/MAX6344s' manual-reset input ( $\overline{\text{MR}}$ ) allows reset to be triggered by a pushbutton switch. The switch is effectively debounced by the 1 $\mu\text{s}$  min reset pulse width.  $\overline{\text{MR}}$  is CMOS-logic compatible.

# 6-Pin $\mu$ P Reset Circuit with Power-Fail Comparator

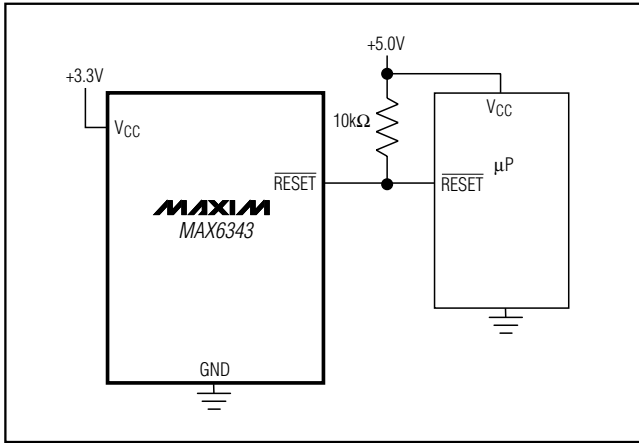

Figure 3. Open-Drain  $\overline{\text{RESET}}$  Output Allows Use with Multiple Supplies

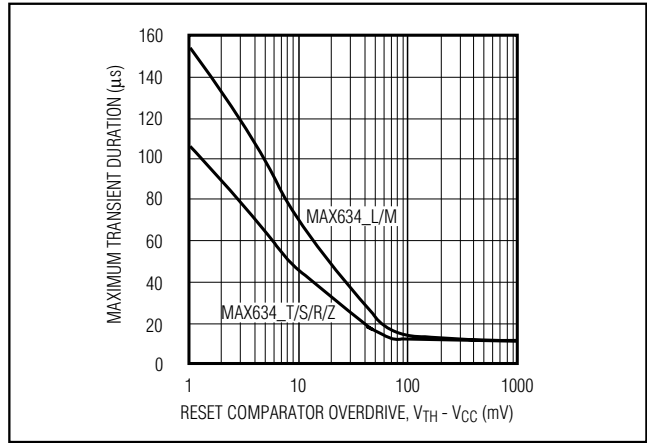

Figure 4. Maximum Transient Duration Magnitude Rejection

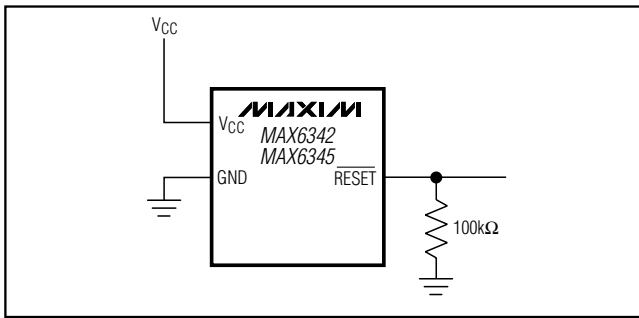

Figure 5. Ensuring  $\overline{\text{RESET}}$  Valid to  $V_{CC} = 0$  on Active-Low Push-Pull Outputs

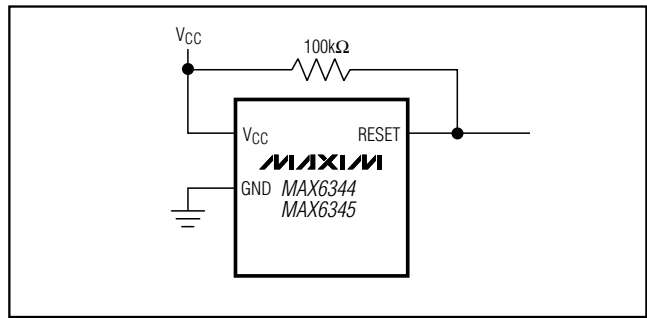

Figure 6. Ensuring  $\overline{\text{RESET}}$  Valid to  $V_{CC} = 0$  on Active-High Push-Pull Outputs

## Power-Fail Comparator

The power-fail comparator is useful for various purposes because the power-fail output ( $\overline{\text{PFO}}$ ) is independent of the reset output. The inverting input is internally connected to a +1.25V reference.

To build an early-warning circuit for power failure, connect the PFI pin to a voltage divider (see the *Typical Operating Circuit*). Choose the voltage-divider ratio so that the voltage at PFI falls below +1.25V just before the +5V regulator drops out. Use  $\overline{\text{PFO}}$  to interrupt the  $\mu$ P to prepare for an orderly shutdown.

## Applications Information

### Negative-Going $V_{CC}$ Transients

The MAX6342–MAX6345 supervisors are immune to short-duration, negative-going  $V_{CC}$  transients (glitches) that usually do not require the entire system to shut down.

Figure 4 shows typical transient duration vs. reset comparator overdrive, for which the MAX6342–MAX6345 do not generate a reset pulse. The graph was generated using a negative-going pulse applied to  $V_{CC}$ , starting

0.5V above the actual reset threshold and ending below it by the magnitude indicated (reset comparator overdrive). The graph indicates the maximum pulse width a negative-going  $V_{CC}$  transient can have without causing a reset pulse. As the magnitude of the transient increases (goes further below the reset threshold), the maximum allowable pulse width decreases.

Typically, a  $V_{CC}$  transient that goes 100mV below the reset threshold and lasts 12 $\mu$ s or less will not cause a reset pulse. A 1 $\mu$ F bypass capacitor mounted as close as possible to the  $V_{CC}$  pin provides additional transient immunity.

### Ensuring a Valid Reset Output Down to $V_{CC} = 0$

The MAX6342–MAX6345 are guaranteed to operate properly down to  $V_{CC} = +1$ V. In applications that require valid reset levels down to  $V_{CC} = 0$ , a pulldown resistor to active-low outputs (MAX6342/MAX6345) and a pullup resistor to active-high outputs (MAX6344/MAX6345) ensure that the reset line is valid when the reset output is no longer sinking or sourcing current (Figures 5 and 6).

# 6-Pin $\mu$ P Reset Circuit with Power-Fail Comparator

MAX6342-MAX6345

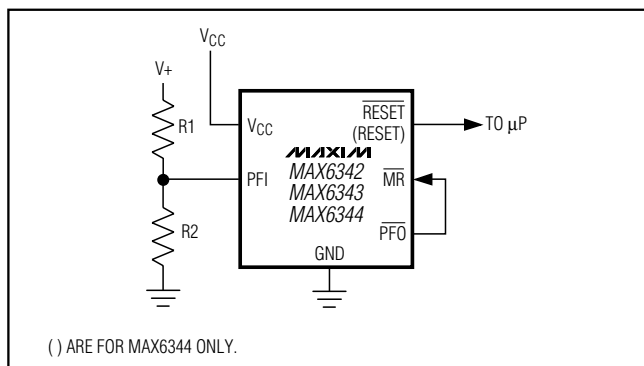

Figure 7. Monitoring Two Supplies

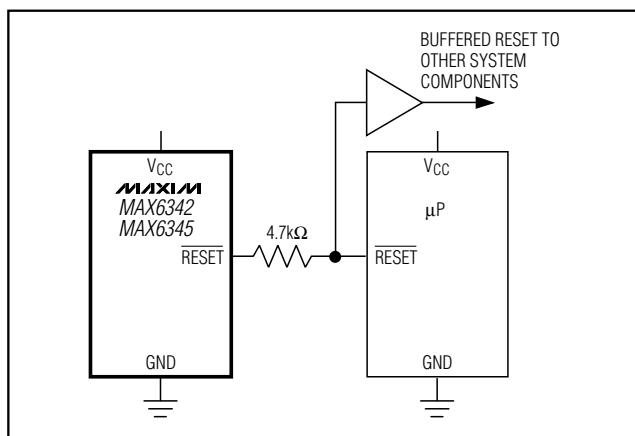

Figure 9. Interfacing to  $\mu$ Ps with Bidirectional Reset I/O

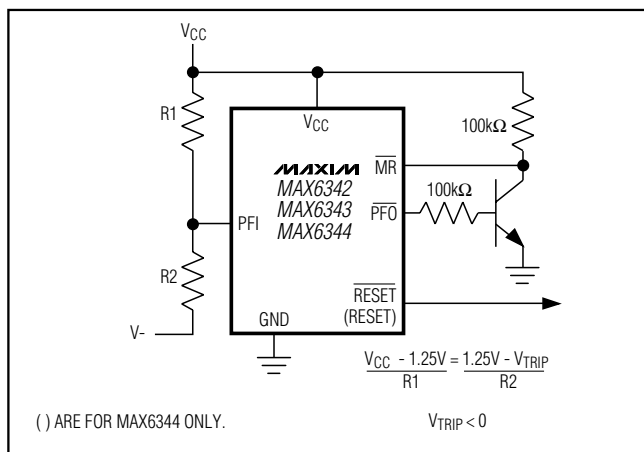

Figure 8. Monitoring a Negative Voltage

Note that this method does not work with the open-drain output of the MAX6343. The resistor value used is not critical, but it must be large enough not to load the reset output when  $V_{CC}$  is above the reset threshold. For most applications,  $100k\Omega$  is adequate.

## Monitoring Two Supplies

Monitor another voltage by connecting a resistor-divider to PFI as shown in Figure 7. The threshold voltage will then be given by:

$$V_{TH(PFI)} = 1.25[(R1 + R2) / R2]$$

where  $V_{TH(PFI)}$  is the threshold at which the monitored voltage will trip  $\overline{PFO}$ .

A good rule of thumb for selecting the resistors is to choose  $R2$  between  $250k\Omega$  and  $500k\Omega$  and solve for  $R1$ . Connect  $\overline{PFO}$  to  $\overline{MR}$  in applications that require reset to assert when the second voltage falls below its threshold.

## Monitoring a Negative Voltage

Connect the circuit as shown in Figure 8 to use the power-fail comparator to monitor a negative supply rail.  $\overline{PFO}$  stays low when  $V_-$  is good. When  $V_-$  rises to cause PFI to be above  $+1.25V$ ,  $\overline{PFO}$  goes high. By adding the resistors and transistor as shown, a high  $\overline{PFO}$  triggers reset. As long as  $\overline{PFO}$  remains high, the MAX6342/MAX6343/MAX6344 will keep reset asserted. Note that the accuracy of this circuit depends on the PFI threshold tolerance, the  $V_{CC}$  line voltage, and the resistors. Also, ensure that the voltage at PFI remains above GND.

## Interfacing to $\mu$ Ps with Bidirectional Reset Pins

### SOT Top Marks

PART	SOT TOP MARK	PART	SOT TOP MARK
MAX6342LUT-T	AACP	MAX6344LUT-T	AADQ
MAX6342MUT-T	AACQ	MAX6344MUT-T	AADR
MAX6342TUT-T	AACR	MAX6344TUT-T	AADS
MAX6342SUT-T	AACS	MAX6344SUT-T	AADT
MAX6342RUT-T	AACT	MAX6344RUT-T	AADU
MAX6342ZUT-T	AACU	MAX6344ZUT-T	AADV
MAX6343LUT-T	AACV	MAX6345LUT-T	AADW
MAX6343MUT-T	AACW	MAX6345MUT-T	AADX
MAX6343TUT-T	AACX	MAX6345TUT-T	AADY
MAX6343SUT-T	AACY	MAX6345SUT-T	AADZ
MAX6343RUT-T	AACZ	MAX6345RUT-T	AAEA
MAX6343ZUT-T	AADA	MAX6345ZUT-T	AAEB

# 6-Pin $\mu$ P Reset Circuit with Power-Fail Comparator

## Typical Operating Circuit

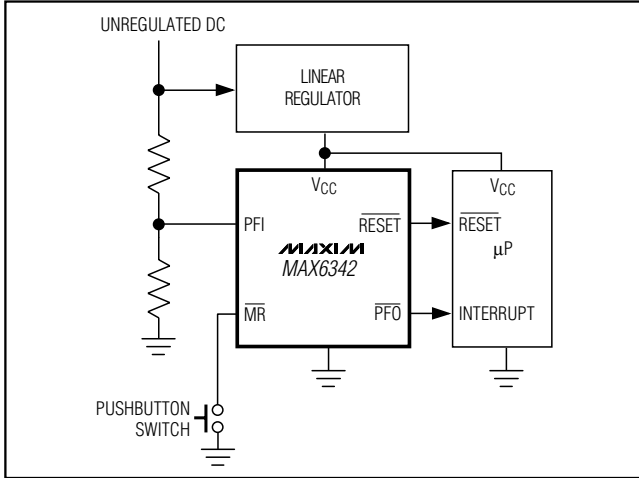

## Pin Configurations (continued)

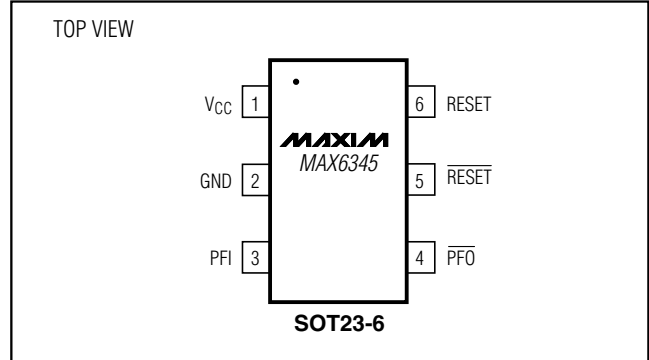

## Chip Information

TRANSISTOR COUNT: 403

## Package Information

(The package drawing(s) in this data sheet may not reflect the most current specifications. For the latest package outline information, go to [www.maxim-ic.com/packages](http://www.maxim-ic.com/packages).)

SYMBOL	MIN	MAX
A	0.90	1.45
A1	0.00	0.15
A2	0.90	1.30
b	0.35	0.50
C	0.08	0.20
D	2.80	3.00
E	2.60	3.00
E1	1.50	1.75
L	0.35	0.60
L1	0.60	REF.
e1	1.90	BSC.
e	0.95	BSC.
alpha	0°	10°

NOTES:  
 1. ALL DIMENSIONS ARE IN MILLIMETERS.  
 2. FOOT LENGTH MEASURED AT INTERCEPT POINT BETWEEN DATUM A & LEAD SURFACE.  
 3. PACKAGE OUTLINE EXCLUSIVE OF MOLD FLASH & METAL BURR. MOLD FLASH, PROTRUSION OR METAL BURR SHOULD NOT EXCEED 0.25 MM.  
 4. PACKAGE OUTLINE INCLUSIVE OF SOLDER PLATING.  
 5. PIN 1 IS LOWER LEFT PIN WHEN READING TOP MARK FROM LEFT TO RIGHT. (SEE EXAMPLE TOP MARK)  
 6. PIN 1 I.D. DOT IS 0.3 MM  $\phi$  MIN. LOCATED ABOVE PIN 1.  
 7. MEETS JEDEC MD17B, VARIATION AB.  
 8. SOLDER THICKNESS MEASURED AT FLAT SECTION OF LEAD BETWEEN 0.08mm AND 0.15mm FROM LEADTIP.  
 9. LEAD TO BE COPLANAR WITHIN 0.1 MM.

6LSOT6PS

-DRAWING NOT TO SCALE-

<b>DALLAS SEMICONDUCTOR</b> <b>MAXIM</b>		
TITLE: PACKAGE OUTLINE, SOT 6L BODY		
APPROVAL:	DOCUMENT CONTROL NO. 21-0058	REV. G 1/1

Maxim cannot assume responsibility for use of any circuitry other than circuitry entirely embodied in a Maxim product. No circuit patent licenses are implied. Maxim reserves the right to change the circuitry and specifications without notice at any time.

8 **Maxim Integrated Products, 120 San Gabriel Drive, Sunnyvale, CA 94086 408-737-7600**

## Looking for pricing, stock, or lifecycle information?

Click below to explore more details on WIN SOURCE:

 [View MAX6342SUT+T on WIN SOURCE](#)

 [Maxim Integrated](#) Information

## Optimize Your Supply Chain with WIN SOURCE Solutions

-  Global Sourcing Solution
-  Obsolete Management
-  Cost Control Management
-  Shortage Management
-  Alternative Solution
-  Excess Inventory Management