



**THE DATASHEET OF  
MAX5930EEG+**





# Low-Voltage, Triple, Hot-Swap Controllers/ Power Sequencers/Voltage Trackers

## General Description

The MAX5930/MAX5931 +1V to +13.2V triple hot-swap controllers provide complete protection for multisupply systems. They allow the safe insertion and removal of circuit cards into live backplanes. These devices hot swap multiple supplies ranging from +1V to +13.2V, provided one supply is at or above +2.7V and only one supply is above 11V. The input voltage rails (channels) can be configured to sequentially turn-on/off, track each other, or have completely independent operation.

The discharged filter capacitors of the circuit card provide low impedance to the live backplane. High inrush currents from the backplane to the circuit card can burn up connectors and components, or momentarily collapse the backplane power supply leading to a system reset. The MAX5930/MAX5931 hot-swap controllers prevent such problems by gradually ramping up the output voltage and regulating the current to a preset limit when the board is plugged in, allowing the system to stabilize safely. After the startup cycle is complete, on-chip comparators provide VariableSpeed/BiLevel™ protection against short-circuit and overcurrent faults, and provide immunity against system noise and load transients.

The load is disconnected in the event of a fault condition. The MAX5930/MAX5931 fault-management mode is selectable, allowing latched fault or autoretry after a fault condition.

The MAX5930/MAX5931 offer a variety of options to reduce external component count and design time. All devices integrate an on-board charge pump to drive the gates of low-cost, external N-channel MOSFETs, an adjustable startup timer, and an adjustable current limit. The devices offer integrated features like startup current regulation and current glitch protection to eliminate external timing resistors and capacitors. The MAX5931L provides an open-drain, active-low status output for each channel, the MAX5931H provides an open-drain, active-high status output for each channel, and the MAX5930 status output polarity is selectable.

The MAX5930 is available in a 24-pin QSOP package, and the MAX5931 is available in a 20-pin QSOP package. All devices are specified over the extended -40°C to +85°C temperature range.

## Applications

Network Switches, Routers, Hubs	Power-Supply Sequencing/Tracking
Hot Plug-In Daughter Cards	Base-Station Line Cards
RAID	Portable Computer Device
Solid-State Circuit Breakers	Bays (Docking Stations)

## Features

- ◆ Safe Hot Swap for +1V to +13.2V Power Supplies with Any Input Voltage ( $V_{IN\_} \geq 2.7V$  and Only One  $V_{IN\_} > 11.0V$ )
- ◆ Adjustable Circuit Breaker/Current-Limit Threshold from 25mV to 100mV
- ◆ Configurable Tracking, Sequencing, or Independent Operation Modes
- ◆ VariableSpeed/BiLevel Circuit-Breaker Response
- ◆ Internal Charge Pumps Generate N-Channel MOSFET Gate Drives
- ◆ Inrush Current Regulated at Startup
- ◆ Autoretry or Latched Fault Management
- ◆ Programmable Undervoltage Lockout
- ◆ Status Outputs Indicate Fault/Safe Condition

## Ordering Information

PART	TEMP RANGE	PIN-PACKAGE
MAX5930EEG	-40°C to +85°C	24 QSOP
MAX5931LEEP	-40°C to +85°C	20 QSOP
MAX5931HEEP	-40°C to +85°C	20 QSOP

Selector Guide and Typical Operating Circuit appear at end of data sheet.

## Pin Configurations

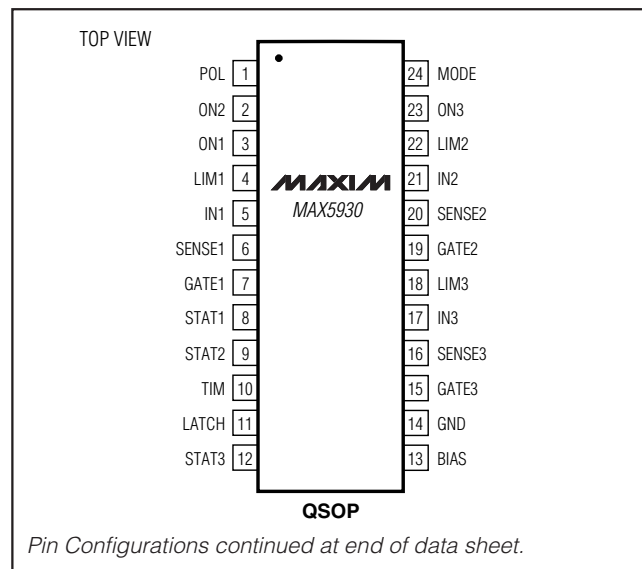

VariableSpeed/BiLevel is a trademark of Maxim Integrated Products, Inc.



# Low-Voltage, Triple, Hot-Swap Controllers/ Power Sequencers/Voltage Trackers

## ABSOLUTE MAXIMUM RATINGS

(All voltages referenced to GND, unless otherwise noted.)

IN_	-0.3V to +14V
GATE_	-0.3V to (IN_ + 6V)
BIAS (Note 1)	(VIN - 0.3V) to +14V
ON_, STAT_, LIM_ (MAX5930), TIM, MODE, LATCH, POL (MAX5930)	-0.3V to (VIN + 0.3V)
SENSE_	-0.3V to (IN_ + 0.3V)
Current into Any Pin	±50mA

Continuous Power Dissipation (TA = +70°C)

20-Pin QSOP (derate 9.1mW/°C above +70°C)	727mW
24-Pin QSOP (derate 9.5mW/°C above +70°C)	762mW
Operating Temperature Range	-40°C to +85°C
Junction Temperature	+150°C
Storage Temperature Range	-65°C to +150°C
Lead Temperature (soldering, 10s)	+300°C

**Note 1:** VIN is the largest of VIN1, VIN2, and VIN3.

Stresses beyond those listed under "Absolute Maximum Ratings" may cause permanent damage to the device. These are stress ratings only, and functional operation of the device at these or any other conditions beyond those indicated in the operational sections of the specifications is not implied. Exposure to absolute maximum rating conditions for extended periods may affect device reliability.

## ELECTRICAL CHARACTERISTICS

(VIN\_ = +1V to +13.2V provided at least one supply is larger than or equal to +2.7V and only one supply is > 11.0V, TA = -40°C to +85°C, unless otherwise noted. Typical values are at VIN1 = 12.0V, VIN2 = 5.0V, VIN3 = 3.3V, VON\_ = +3.3V, and TA = +25°C.) (Notes 1, 2)

PARAMETER	SYMBOL	CONDITIONS	MIN	TYP	MAX	UNITS	
<b>POWER SUPPLIES</b>							
IN_ Input Voltage Range	VIN_	At least one VIN_ ≥ +2.7V and only one VIN_ > 11.0V	1.0		13.2	V	
Supply Current	IQ	IIN1 + IIN2 + IIN3, VON_ = 2.7V, VIN_ = +13.2V, after STAT_high		2.5	5	mA	
<b>CURRENT CONTROL</b>							
Slow-Comparator Threshold (VIN_ - VSENSE_) (Note 3)	VSC,TH	LIM_ = GND (MAX5930), MAX5931 (Note 4)	TA = +25°C	22.5	25	27.5	mV
			TA = -40°C to +85°C	21.0		27.5	
			RLIM_ = 10kΩ (MAX5930)	80		125	
			RLIM_ from LIM_ to GND (MAX5930)	RLIM_ x 7.5 x 10 <sup>-6</sup> + 25mV			
Slow-Comparator Response Time (Note 4)	tSCD	1mV overdrive		3		ms	
		50mV overdrive		130		μs	
Fast-Comparator Threshold (VIN_ - VSENSE_)	VFC,TH			2 x VSC,TH		mV	
Fast-Comparator Response Time	tFCD	10mV overdrive, from overload condition		200		ns	
SENSE_ Input Bias Current	IB SENSE_	VSENSE_ = VIN_		0.03	1	μA	
<b>MOSFET DRIVER</b>							
Startup Period (Note 5)	tSTART	RTIM = 100kΩ	8.0	10.8	13.6	ms	
		RTIM = 4kΩ (minimum value)	0.30	0.4	0.55		
		TIM floating (default)	5	9	14		

# Low-Voltage, Triple, Hot-Swap Controllers/ Power Sequencers/Voltage Trackers

MAX5930/MAX5931

## ELECTRICAL CHARACTERISTICS (continued)

( $V_{IN\_} = +1V$  to  $+13.2V$  provided at least one supply is larger than or equal to  $+2.7V$  and only one supply is  $> 11.0V$ ,  $T_A = -40^{\circ}C$  to  $+85^{\circ}C$ , unless otherwise noted. Typical values are at  $V_{IN1} = 12.0V$ ,  $V_{IN2} = 5.0V$ ,  $V_{IN3} = 3.3V$ ,  $V_{ON\_} = +3.3V$ , and  $T_A = +25^{\circ}C$ .) (Notes 1, 2)

PARAMETER	SYMBOL	CONDITIONS	MIN	TYP	MAX	UNITS
Average Gate Current	IGATE	Charging, $V_{GATE\_} = GND$ , $V_{IN\_} = +5V$ (Note 6)	80	100	125	$\mu A$
		Discharging, during startup		100		
		Discharging, normal turn-off or triggered by the slow comparator after startup; $V_{GATE\_} = 5V$ , $V_{IN\_} = 10V$ , $V_{ON\_} = 0V$	2	3	7	$mA$
		Discharging, triggered by a fault after startup; $V_{GATE\_} = 5V$ , $V_{IN\_} = 10V$ , ( $V_{IN\_} - V_{SENSE\_} > V_{FC,TH\_}$ ) (Note 7)	30	50	120	
Gate-Drive Voltage	VDRIVE	$V_{GATE\_} - V_{IN\_}$ , $I_{GATE\_} = 1\mu A$	4.9	5.3	5.6	V
<b>ON COMPARATOR</b>						
ON_ Threshold	VON_,TH	Low to high	0.85	0.875	0.90	V
		Hysteresis		25		mV
ON_ Propagation Delay		10mV overdrive		10		$\mu s$
ON_ Voltage Range	VON_	Without false output inversion			$V_{IN}$	V
ON_ Input Bias Current	IBON	$V_{ON\_} = V_{IN}$		0.03	1	$\mu A$
ON_ Pulse-Width Low	tUNLATCH	To unlatch after a latched fault	100			$\mu s$
<b>DIGITAL OUTPUTS (STAT_)</b>						
Output Leakage Current		$V_{STAT\_} \leq 13.2V$			1	$\mu A$
Output Voltage Low	VOL_	POL = floating (MAX5930), $I_{SINK} = 1mA$			0.4	V
<b>UNDERVOLTAGE LOCKOUT (UVLO)</b>						
UVLO Threshold	VUVLO	Startup is initiated when this threshold is reached by any $V_{IN\_}$ and $V_{ON\_} > 0.9V$ (Note 8)	2.25	2.45	2.65	V
UVLO Hysteresis	VUVLO,HYST			250		mV
UVLO Glitch Filter Reset Time	tD,GF	$V_{IN} < V_{UVLO}$ maximum pulse width to reset			10	$\mu s$
UVLO to Startup Delay	tD,UVLO	Time input voltage must exceed $V_{UVLO}$ before startup is initiated	20	37.5	60	ms
Input Power-Ready Threshold	VPWRRDY	(Note 9)	0.9	0.95	1.0	V
Input Power-Ready Hysteresis	VPWRHYST			50		mV
<b>LOGIC AND TIMING</b>						
POL Input Pullup	IPOL	POL = GND (MAX5930)	2	4	6	$\mu A$
LATCH Input Pullup	ILATCH	LATCH = GND	2	4	6	$\mu A$
MODE Input Voltage	VMODE	MODE floating (default to sequencing mode)	1.0	1.25	1.5	V
Independent-Mode Selection Threshold	VINDEP,TH	VMODE rising			0.4	V
Tracking-Mode Selection Threshold	VTRACK,TH	VMODE rising	2.7			V

# Low-Voltage, Triple, Hot-Swap Controllers/ Power Sequencers/Voltage Trackers

## ELECTRICAL CHARACTERISTICS (continued)

( $V_{IN\_}$  = +1V to +13.2V provided at least one supply is larger than or equal to +2.7V and only one supply is > 11.0V,  $T_A$  = -40°C to +85°C, unless otherwise noted. Typical values are at  $V_{IN1}$  = 12.0V,  $V_{IN2}$  = 5.0V,  $V_{IN3}$  = 3.3V,  $V_{ON\_}$  = +3.3V, and  $T_A$  = +25°C.) (Notes 1, 2)

PARAMETER	SYMBOL	CONDITIONS	MIN	TYP	MAX	UNITS
MODE Input Impedance	$R_{MODE}$			200		$k\Omega$
Autoretry Delay	$t_{RETRY}$	Delay time to restart after fault shutdown		64 x $t_{START}$		ms

**Note 2:** All devices are 100% tested at  $T_A$  = +25°C. Limits over temperature are guaranteed by design.

**Note 3:** The slow-comparator threshold is adjustable.  $V_{SC,TH}$  =  $R_{LIM} \times 7.5\mu A + 25mV$  (see the *Typical Operating Characteristics*).

**Note 4:** The current-limit slow-comparator response time is weighed against the amount of overcurrent, the higher the overcurrent condition, the faster the response time (see the *Typical Operating Characteristics*).

**Note 5:** The startup period ( $t_{START}$ ) is the time during which the slow comparator is ignored and the device acts as a current-limiter by regulating the sense current with the fast comparator (see the *Startup Period* section).

**Note 6:** The current available at GATE is a function of  $V_{GATE}$  (see the *Typical Operating Characteristics*).

**Note 7:** After a fault triggered by the fast comparator, the gate is discharged by the strong discharge current.

**Note 8:** Each channel input while the other inputs are at +1V.

**Note 9:** Each channel input while any other input is at +3.3V.

## Typical Operating Characteristics

(Typical Operating Circuits, Q1 = Q2 = Q3 = Fairchild FDB7090L,  $V_{IN1}$  = +12.0V,  $V_{IN2}$  = +5.0V,  $V_{IN3}$  = +1V,  $T_A$  = +25°C, unless otherwise noted. Channels 1 through 3 are identical in performance. Where characteristics are interchangeable, channels 1 through 3 are referred to as X, Y, and Z.)

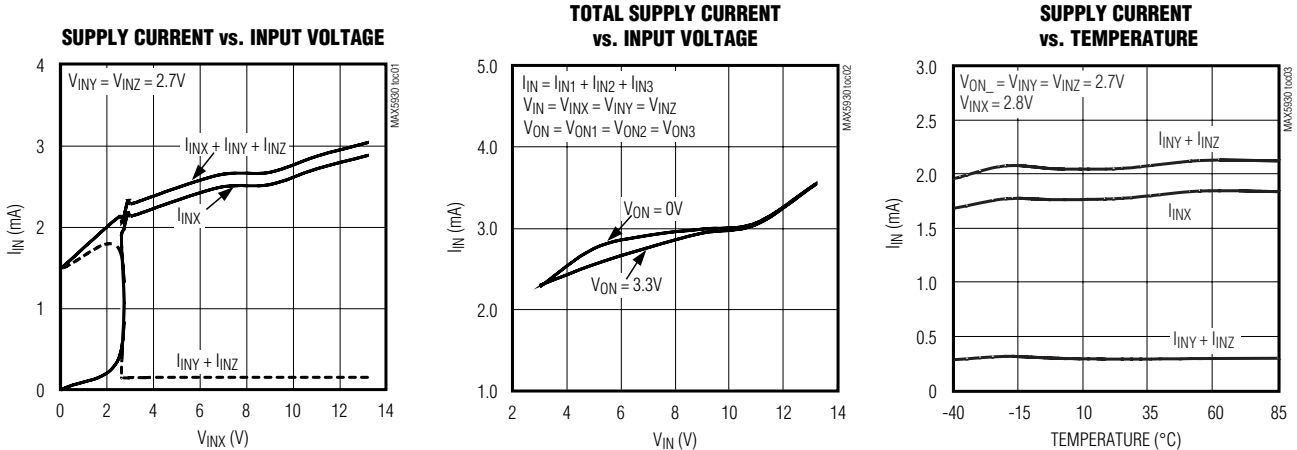

# Low-Voltage, Triple, Hot-Swap Controllers/ Power Sequencers/Voltage Trackers

## Typical Operating Characteristics (continued)

(Typical Operating Circuits, Q1 = Q2 = Q3 = Fairchild FDB7090L,  $V_{IN1} = +12.0V$ ,  $V_{IN2} = +5.0V$ ,  $V_{IN3} = +1V$ ,  $T_A = +25^\circ C$ , unless otherwise noted. Channels 1 through 3 are identical in performance. Where characteristics are interchangeable, channels 1 through 3 are referred to as X, Y, and Z.)

MAX5930/MAX5931

**GATE-DRIVE VOLTAGE  
vs. INPUT VOLTAGE**

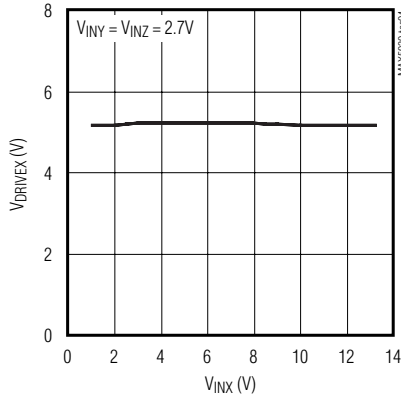

**GATE CHARGE CURRENT  
vs. GATE VOLTAGE**

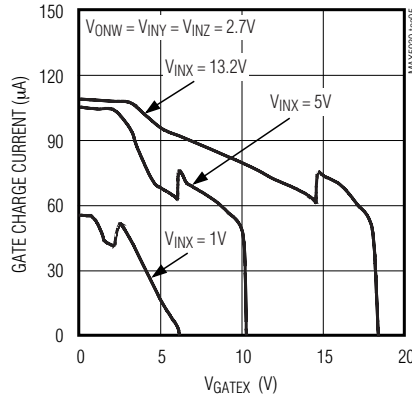

**GATE CHARGE CURRENT  
vs. TEMPERATURE**

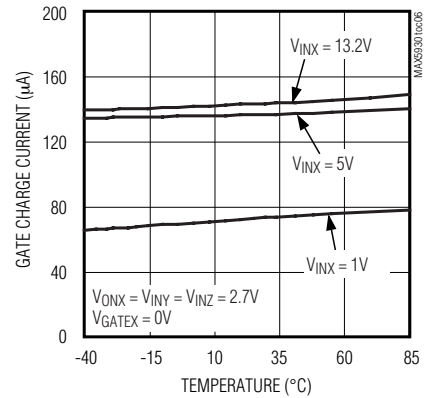

**STRONG GATE DISCHARGE CURRENT  
vs. GATE VOLTAGE**

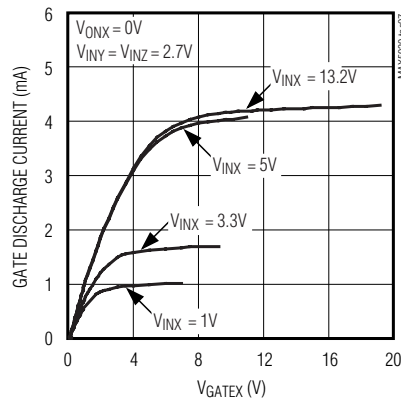

**STRONG GATE DISCHARGE CURRENT  
vs. TEMPERATURE**

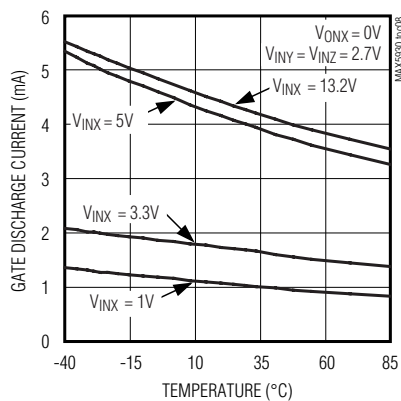

**TURN-OFF TIME  
vs. SENSE VOLTAGE**

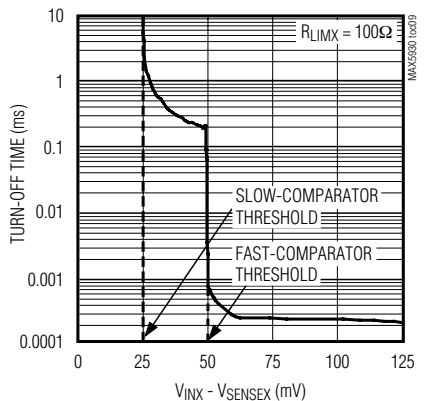

**TURN-OFF TIME vs. SENSE VOLTAGE  
(EXPANDED SCALE)**

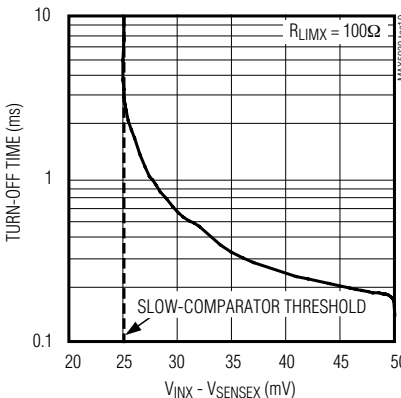

**SLOW-COMPARATOR THRESHOLD  
vs. R\_LIMX**

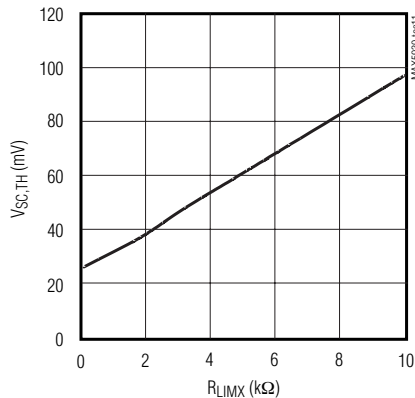

**STARTUP PERIOD  
vs. R\_TIM**

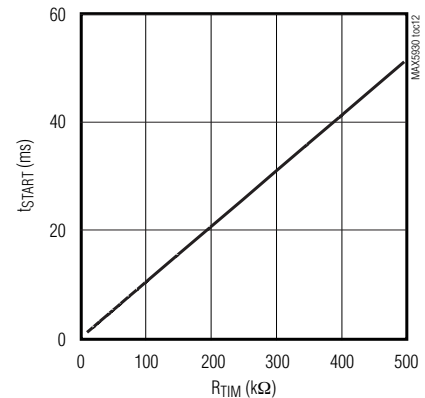

# Low-Voltage, Triple, Hot-Swap Controllers/ Power Sequencers/Voltage Trackers

## Typical Operating Characteristics (continued)

(Typical Operating Circuits, Q1 = Q2 = Q3 = Fairchild FDB7090L,  $V_{IN1} = +12.0V$ ,  $V_{IN2} = +5.0V$ ,  $V_{IN3} = +1V$ ,  $T_A = +25^\circ C$ , unless otherwise noted. Channels 1 through 3 are identical in performance. Where characteristics are interchangeable, channels 1 through 3 are referred to as X, Y, and Z.)

**TURN-OFF TIME  
SLOW-COMPARATOR FAULT**

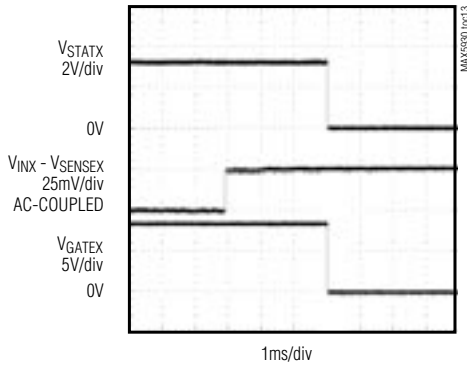

**TURN-OFF TIME  
FAST-COMPARATOR FAULT**

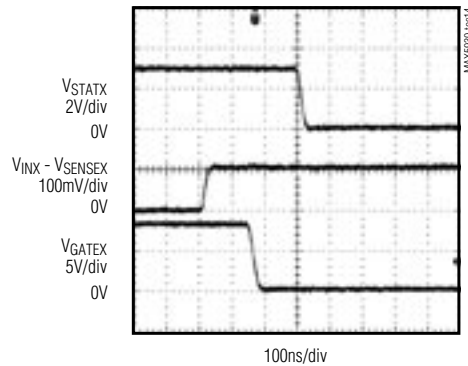

**STARTUP WAVEFORMS FAST TURN-ON  
( $C_{GATE} = 0nF$ ,  $C_{BOARD} = 1000\mu F$ )**

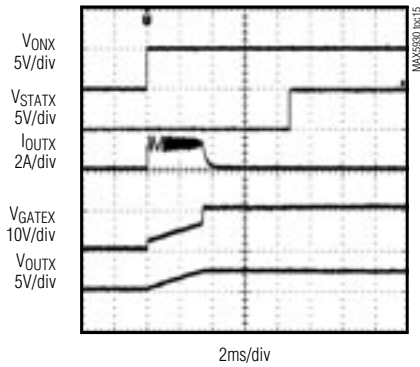

**STARTUP WAVEFORMS SLOW TURN-ON  
( $C_{GATE} = 0.22\mu F$ ,  $C_{BOARD} = 1000\mu F$ )**

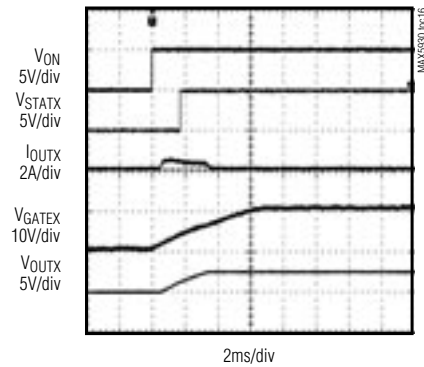

**AUTORETRY DELAY**

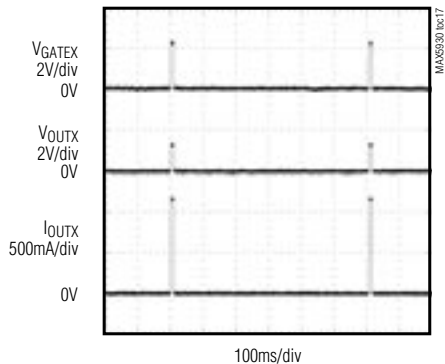

**TURN-ON IN  
VOLTAGE-TRACKING MODE**

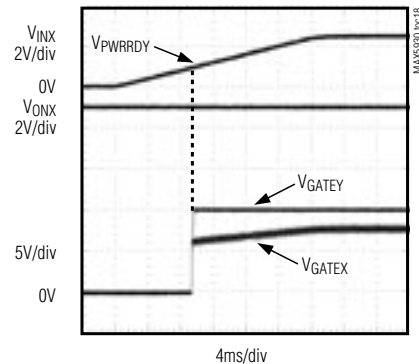

# Low-Voltage, Triple, Hot-Swap Controllers/ Power Sequencers/Voltage Trackers

## Typical Operating Characteristics (continued)

(Typical Operating Circuits, Q1 = Q2 = Q3 = Fairchild FDB7090L,  $V_{IN1} = +12.0V$ ,  $V_{IN2} = +5.0V$ ,  $V_{IN3} = +1V$ ,  $T_A = +25^\circ C$ , unless otherwise noted. Channels 1 through 3 are identical in performance. Where characteristics are interchangeable, channels 1 through 3 are referred to as X, Y, and Z.)

MAX5930/MAX5931

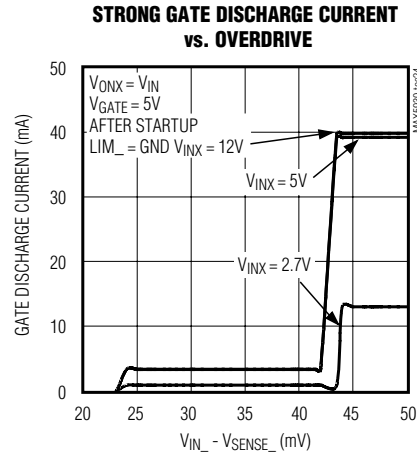
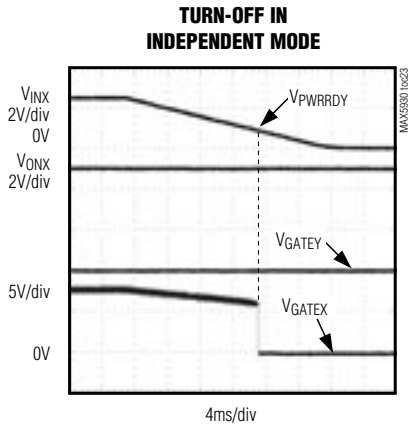
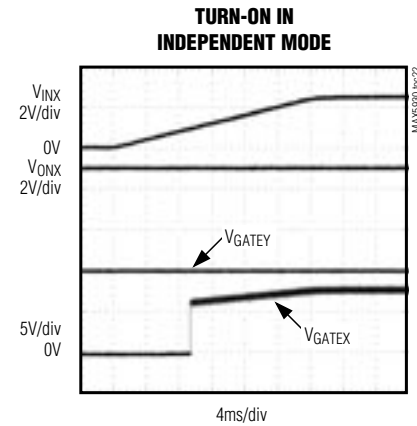
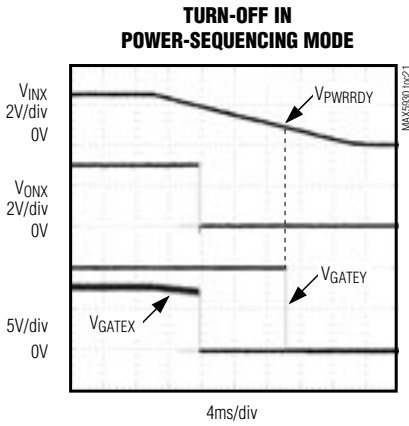
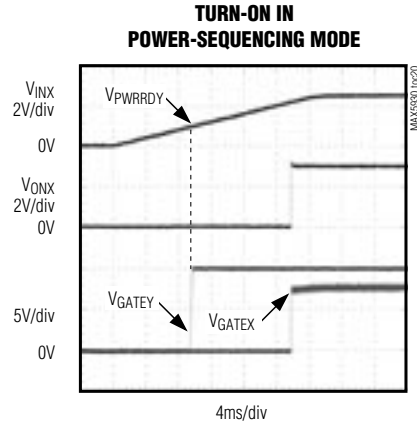
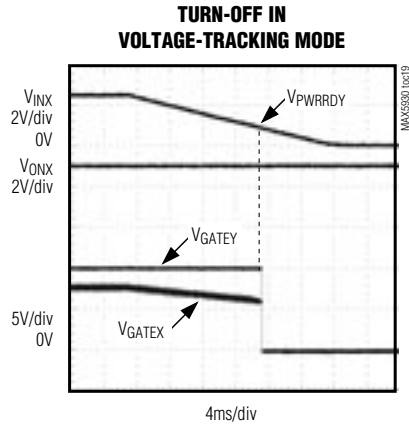

# Low-Voltage, Triple, Hot-Swap Controllers/ Power Sequencers/Voltage Trackers

## Pin Description

PIN		NAME	FUNCTION
MAX5930	MAX5931		
1	—	POL	STAT Output-Polarity Select (See Table 3 and the <i>Status Output</i> Section)
2	1	ON2	On/Off Channel 2 Control Input (See the <i>Mode</i> Section)
3	2	ON1	On/Off Channel 1 Control Input (See the <i>Mode</i> Section)
4	—	LIM1	Channel 1 Current-Limit Setting. Connect a resistor from LIM1 to GND to set current-trip level. Connect to GND for the default 25mV threshold. Do not leave LIM1 open.
5	3	IN1	Channel 1 Supply Input. Connect to a 1V to 13.2V supply voltage and to one end of R <sub>SENSE1</sub> . Bypass with a 0.1μF capacitor to ground.
6	4	SENSE1	Channel 1 Current-Sense Input. Connect SENSE1 to the drain of an external MOSFET and to one end of R <sub>SENSE1</sub> .
7	5	GATE1	Channel 1 Gate-Drive Output. Connect to gate of external N-channel MOSFET.
8	6	STAT1	Open-Drain Status Signal for Channel 1. STAT1 asserts when hot swap is successful and t <sub>START</sub> has elapsed. STAT1 deasserts if ON1 is low, or if channel 1 is turned off for any fault condition.
9	7	STAT2	Open-Drain Status Signal for Channel 2. STAT2 asserts when hot swap is successful and t <sub>START</sub> has elapsed. STAT2 deasserts if ON2 is low, or if channel 2 is turned off for any fault condition.
10	8	TIM	Startup Timer Setting. Connect a resistor from TIM to GND to set the startup period. Leave TIM unconnected for the default startup period of 9ms. R <sub>TIM</sub> must be between 4kΩ and 500kΩ.
11	9	LATCH	Latch/Autoretry Selection Input. Connect LATCH to GND for autoretry mode after a fault. Leave LATCH open for latch mode.
12	10	STAT3	Open-Drain Status Signal for Channel 3. STAT3 asserts when hot swap is successful and t <sub>START</sub> has elapsed. STAT3 deasserts if ON3 is low, or if channel 3 is turned off for any fault condition.
13	11	BIAS	Supply Reference Output. The highest supply is available at BIAS for filtering. Connect a 1nF to 10nF ceramic capacitor from BIAS to GND. No other connections are allowed to BIAS.
14	12	GND	Ground
15	13	GATE3	Channel 3 Gate-Drive Output. Connect to gate of external N-channel MOSFET.
16	14	SENSE3	Channel 3 Current-Sense Input. Connect SENSE3 to the drain of an external MOSFET and to one end of R <sub>SENSE3</sub> .
17	15	IN3	Channel 3 Supply Input. Connect to a supply voltage from 1V to 13.2V and to one end of R <sub>SENSE3</sub> . Bypass with a 0.1μF capacitor to ground.
18	—	LIM3	Channel 3 Current-Limit Setting. Connect a resistor from LIM3 to GND to set current-trip level. Connect to GND for the default 25mV threshold. Do not leave LIM3 open.
19	16	GATE2	Channel 2 Gate-Drive Output. Connect to gate of external N-channel MOSFET.
20	17	SENSE2	Channel 2 Current-Sense Input. Connect SENSE2 to the drain of an external MOSFET and to one end of R <sub>SENSE2</sub> .
21	18	IN2	Channel 2 Supply Input. Connect to a 1V to 13.2V supply voltage and to one end of R <sub>SENSE2</sub> . Bypass with a 0.1μF capacitor to ground.

# Low-Voltage, Triple, Hot-Swap Controllers/ Power Sequencers/Voltage Trackers

## Pin Description (continued)

PIN		NAME	FUNCTION
MAX5930	MAX5931		
22	—	LIM2	Channel 2 Current-Limit Setting. Connect a resistor from LIM2 to GND to set current-trip level. Connect to GND for the default 25mV threshold. Do not leave LIM2 open.
23	19	ON3	On/Off Channel 3 Control Input (See the <i>Mode</i> Section)
24	20	MODE	Mode Configuration Input. Mode is configured according to Table 1 as soon as one of the IN_ voltages exceeds UVLO and before turning on OUT_ (see the <i>Mode</i> section).

### Detailed Description

The MAX5930/MAX5931 are circuit-breaker ICs for hot-swap applications where a line card is inserted into a live backplane. The MAX5930/MAX5931 operate down to 1V provided one of the inputs is above 2.7V and only one supply is above 11V. Normally, when a line card is plugged into a live backplane, the card's discharged filter capacitors provide low impedance that can momentarily cause the main power supply to collapse. The MAX5930/MAX5931 reside either on the backplane or on the removable card to provide inrush current limiting and short-circuit protection. This is achieved by using external N-channel MOSFETs, external current-sense resistors, and on-chip comparators. The startup period and current-limit threshold of the MAX5930/MAX5931 can be adjusted with external resistors. Figure 1 shows the MAX5930/MAX5931 functional diagram.

The MAX5930 offers three programmable current limits, selectable fault-management mode, and selectable STAT\_ output polarity. The MAX5930 features fixed current limits, selectable fault-management mode, and fixed STAT\_ output polarity.

### Mode

The MAX5930/MAX5931 supports three modes of operation: voltage-tracking, power-sequencing, and independent mode. Select the appropriate mode according to Table 1.

#### Voltage-Tracking Mode

Connect MODE high to enter voltage-tracking mode. While in voltage-tracking mode, all channels turn on and off together. To turn all channels on:

- At least one  $V_{IN\_}$  must exceed  $V_{UVLO}$  (2.45V) for the UVLO to startup delay (37.5ms).
- All  $V_{IN\_}$  must exceed  $V_{PWRRDY}$  (0.95V).
- All  $V_{ON\_}$  must exceed  $V_{ON,TH}$  (0.875V).
- No faults may be present on any channel.

The MAX5930/MAX5931 turns off all channels if any of the above conditions are not met. After a fault-latched shutdown, cycle any of the ON\_ pins to unlatch and restart all channels.

#### Power-Sequencing Mode

Leave MODE floating to enter power-sequencing mode. While in power-sequencing mode, the MAX5930/MAX5931 turn on and off each channel depending on the state of the corresponding  $V_{ON\_}$ . To turn on a given channel:

- At least one  $V_{IN\_}$  must exceed  $V_{UVLO}$  (2.45V) for the UVLO to startup delay (37.5ms).
- All  $V_{IN\_}$  must exceed  $V_{PWRRDY}$  (0.95V).
- The corresponding  $V_{ON\_}$  must exceed  $V_{ON,TH}$  (0.875V).
- No faults may be present on any channel.

The MAX5930/MAX5931 turn off all channels if any of the above conditions are not met. After a fault-latched shutdown, cycle any of the ON\_ pins to unlatch and restart all channels, dependent on the corresponding  $V_{ON\_}$  state.

#### Independent Mode

Tie MODE to GND to enter independent mode. While in independent mode the MAX5930/MAX5931 provide complete independent control for each channel. To turn on a given channel:

- At least one  $V_{IN\_}$  must exceed  $V_{UVLO}$  (2.45V) for the UVLO to startup delay (37.5ms).
- The corresponding  $V_{IN\_}$  must exceed  $V_{PWRRDY}$  (0.95V).
- The corresponding  $V_{ON\_}$  must exceed  $V_{ON,TH}$  (0.875V).

**Table 1. Operational Mode Selection**

MODE	OPERATION
High (Connect to BIAS)	Voltage Tracking
OPEN	Voltage Sequencing
GND	Independent

# Low-Voltage, Triple, Hot-Swap Controllers/ Power Sequencers/Voltage Trackers

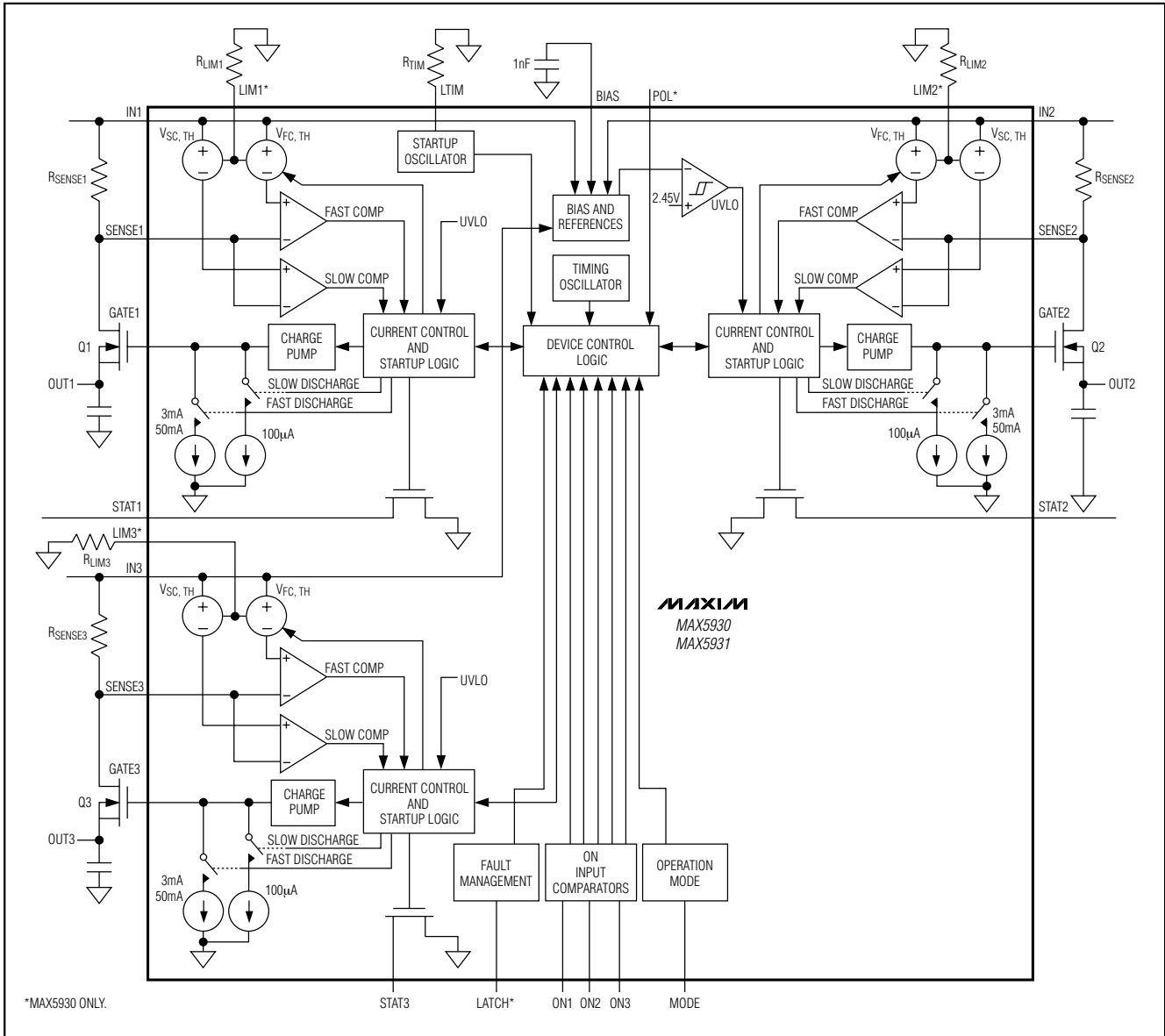

Figure 1. Functional Diagram

The MAX5930/MAX5931 turn off the corresponding channel if any of the above conditions are not met. During a fault condition on a given channel only, the affected channel is disabled. After a fault-latched shut-down, recycle the corresponding ON<sub>n</sub> inputs to unlatch and restart only the corresponding channel.

### Startup Period

RTIM sets the duration of the startup period from 0.4ms (RTIM = 4kΩ) to 51ms (RTIM = 500kΩ) (see the *Setting the Startup Period, RTIM* section). The default startup period is fixed at 9ms when TIM is floating. The startup period begins after the turn-on conditions are met as described in the *Mode* section, and the device is not latched or in its autoretry delay (see the *Latched and Autoretry Overcurrent Fault Management* section).

# Low-Voltage, Triple, Hot-Swap Controllers/ Power Sequencers/Voltage Trackers

MAX5930/MAX5931

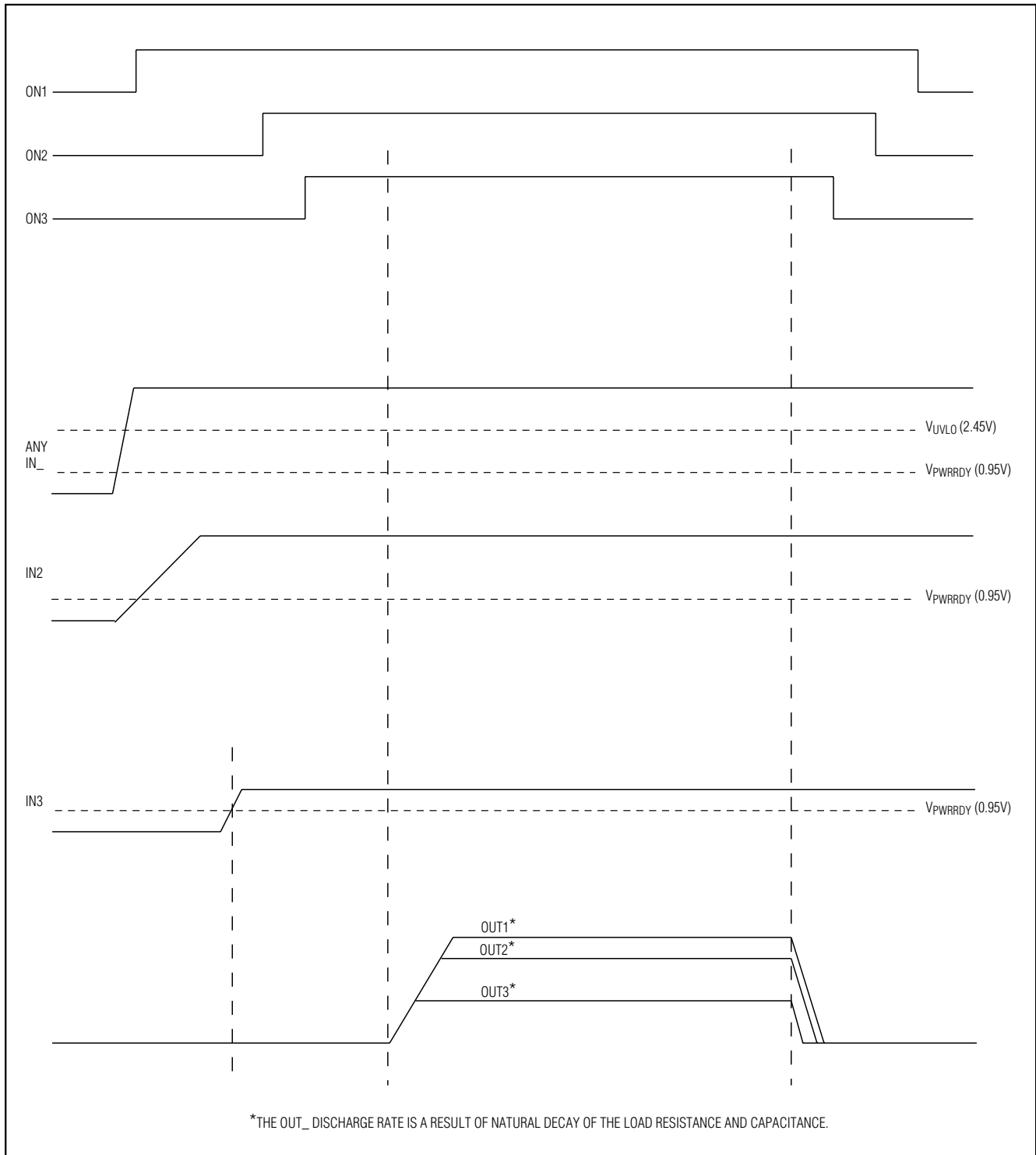

Figure 2. Voltage-Tracking Timing Diagram (Provided  $t_D$ ,  $UVLO$  Requirement is Met)

# Low-Voltage, Triple, Hot-Swap Controllers/ Power Sequencers/Voltage Trackers

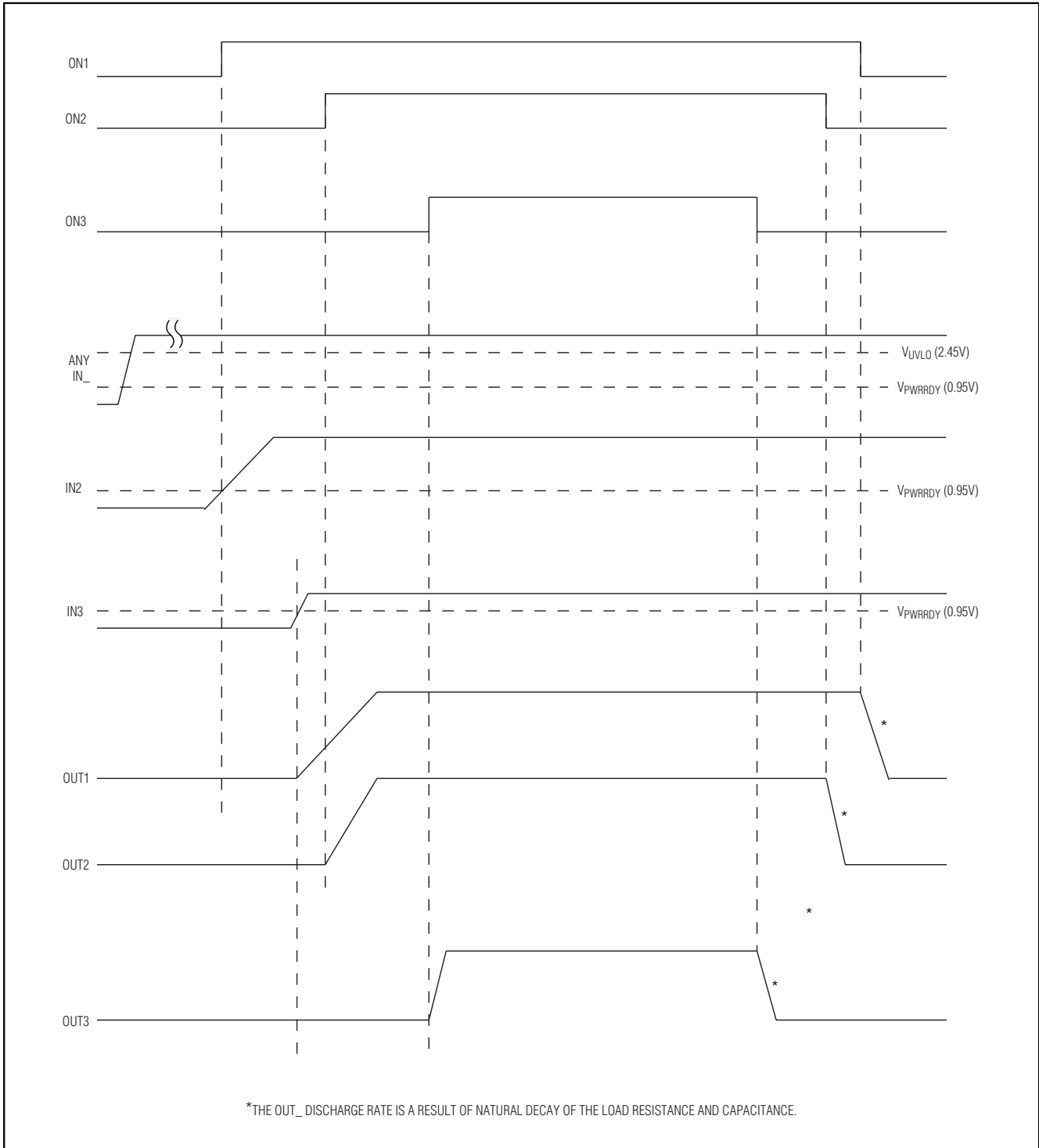

Figure 3. Power-Sequencing Timing Diagram (Provided  $t_D$ ,  $UVLO$  Requirement is Met)

# Low-Voltage, Triple, Hot-Swap Controllers/ Power Sequencers/Voltage Trackers

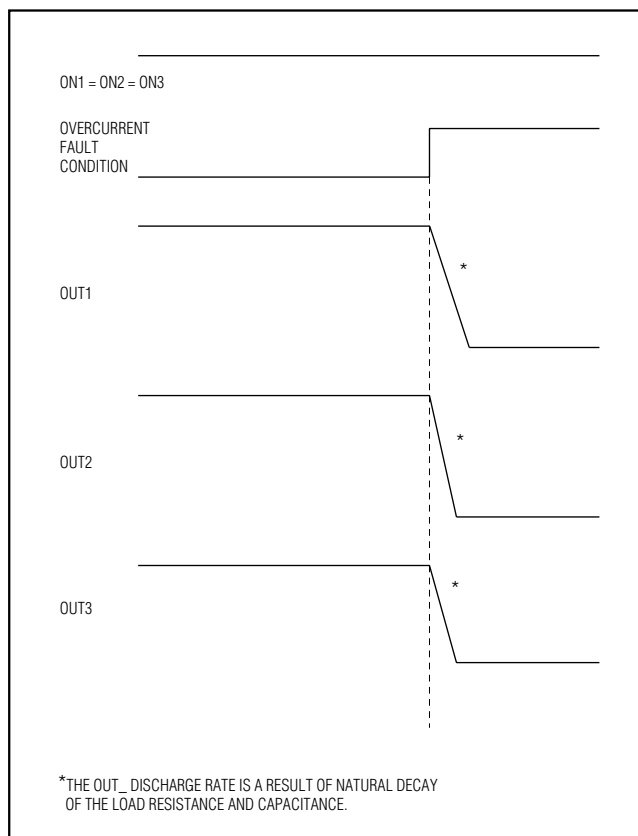

Figure 4. Power-Sequencing Fault Turn-Off

The MAX5930/MAX5931 limit the load current if an overcurrent fault occurs during startup instead of completely turning off the external MOSFETs. The slow comparator is disabled during the startup period and the load current can be limited in two ways:

- 1) Slowly enhancing the MOSFETs by limiting the MOSFET gate-charging current.
- 2) Limiting the voltage across the external current-sense resistor.

During the startup period, the gate-drive current is limited to 100 $\mu$ A and decreases with the increase of the gate voltage (see the *Typical Operating Characteristics*). This allows the controller to slowly enhance the MOSFETs. If the fast comparator detects an overcurrent, the MAX5930/MAX5931 regulate the gate voltage to ensure that the voltage across the sense resistor does not

exceed  $V_{SU,TH}$ . This effectively regulates the inrush current during startup.

Figure 6 shows the startup waveforms. STAT<sub>i</sub> is asserted immediately after the startup period if no fault condition is present.

### VariableSpeed/BiLevel Fault Protection

VariableSpeed/BiLevel fault protection incorporates comparators with different thresholds and response times to monitor the load current (Figure 7). During the startup period, protection is provided by limiting the load current. Protection is provided in normal operation (after the startup period has expired) by discharging the MOSFET gates with a strong 3mA/50mA pulldown current in response to a fault condition. After a fault, STAT<sub>i</sub> is deasserted. Use the LATCH input to control whether the STAT<sub>i</sub> outputs latch off or autoretry (see the *Latched and Autoretry Fault Management* section).

### Slow-Comparator Startup Period

The slow comparator is disabled during the startup period while the external MOSFETs are turning on. Disabling the slow comparator allows the device to ignore the higher-than-normal inrush current charging the board capacitors when a card is first plugged into a live backplane.

### Slow-Comparator Normal Operation

After the startup period is complete, the slow comparator is enabled and the device enters normal operation. The comparator threshold voltage ( $V_{SC,TH}$ ) is adjustable from 25mV to 100mV. The slow-comparator response time is 3ms for a 1mV overdrive. The response time decreases to 100 $\mu$ s with a large overdrive. The variable-speed response time allows the MAX5930/MAX5931 to ignore low-amplitude momentary glitches, thus increasing system noise immunity. After an extended overcurrent condition, a fault is generated, STAT<sub>i</sub> outputs are deasserted and the MOSFET gates are discharged with a 3mA pulldown current.

### Fast-Comparator Startup Period

During the startup period, the fast comparator regulates the gate voltages to ensure that the voltage across the sense resistor does not exceed the startup fast-comparator threshold voltage ( $V_{SU,TH}$ ).  $V_{SU,TH}$  is scaled to two times the slow-comparator threshold ( $V_{SC,TH}$ ).

# Low-Voltage, Triple, Hot-Swap Controllers/ Power Sequencers/Voltage Trackers

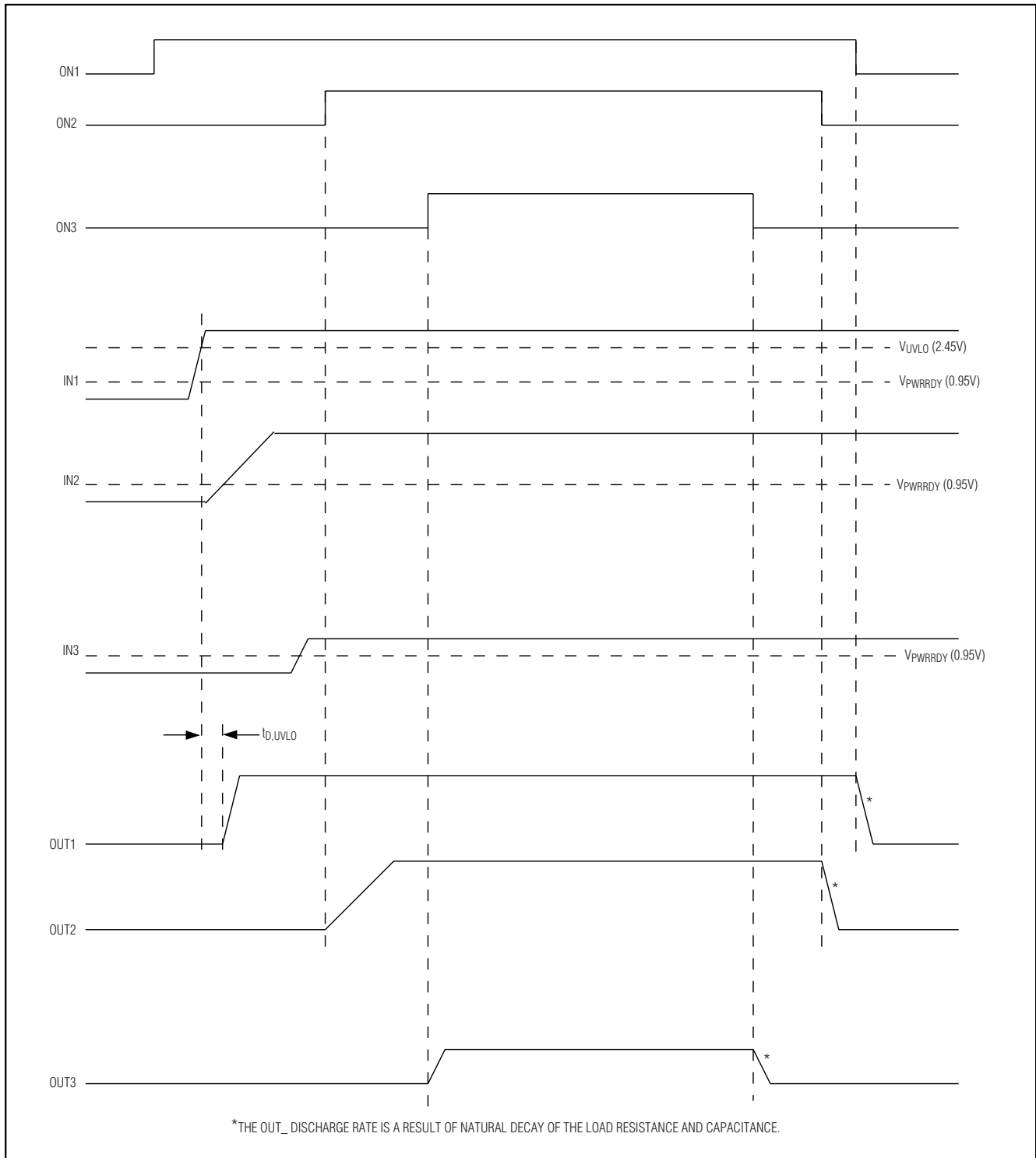

Figure 5. Independent-Mode Timing Diagram

# Low-Voltage, Triple, Hot-Swap Controllers/ Power Sequencers/Voltage Trackers

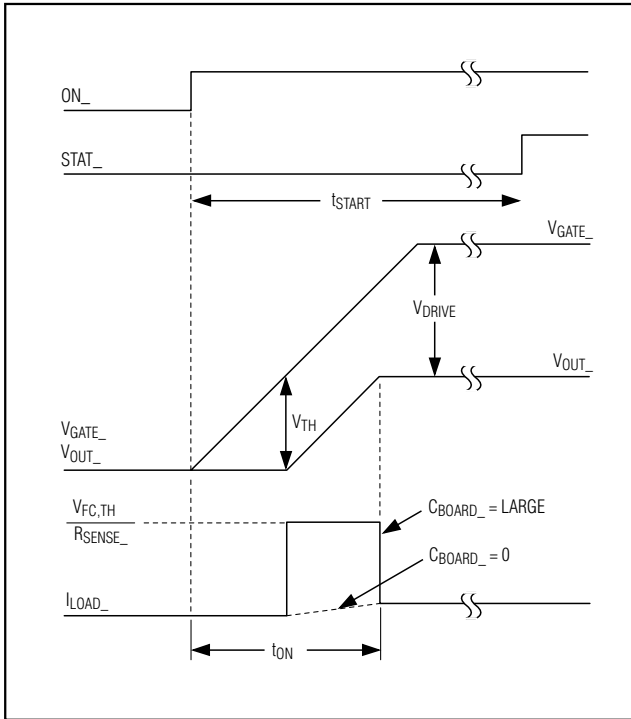

Figure 6. Independent-Mode Startup Waveforms

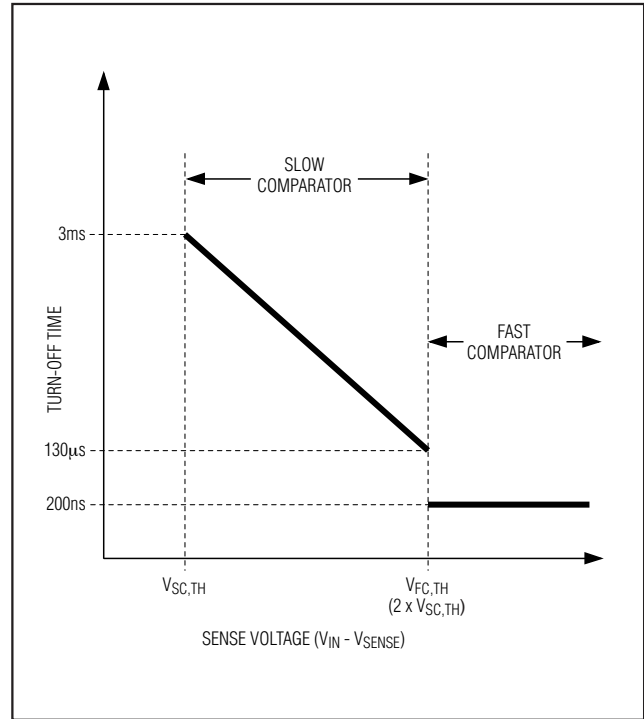

Figure 7. VariableSpeed/BiLevel Response

### Fast-Comparator Normal Operation

In normal operation, if the load current reaches the fast-comparator threshold, a fault is generated, STAT\_ is deasserted, and the MOSFET gates are discharged with a strong 50mA pulldown current. This happens in the event of a serious current overload or a dead short. The fast-comparator threshold voltage ( $V_{FC,TH}$ ) is scaled to two times the slow-comparator threshold ( $V_{SC,TH}$ ). This comparator has a fast response time of 200ns (Figure 7).

### Undervoltage Lockout (UVLO)

The UVLO prevents the MAX5930/MAX5931 from turning on the external MOSFETs until one input voltage exceeds the UVLO threshold (2.45V) for  $t_{D,UVLO}$ . The MAX5930/MAX5931 use power from the highest input voltage rail for the charge pumps. This allows for more efficient charge-pump operation. The highest  $V_{IN}$  is provided as an output at BIAS. The UVLO protects the external MOSFETs from an insufficient gate-drive voltage.  $t_{D,UVLO}$  ensures that the board is fully inserted into the backplane and that the input voltages are stable. The MAX5930/MAX5931 includes a UVLO glitch filter ( $t_{D,GF}$ ) to reject all input voltage noise and transients.

Bringing all input supplies below the UVLO threshold for longer than  $t_{D,GF}$  reinitiates  $t_{D,UVLO}$  and the startup period,  $t_{START}$ . See Figure 8 for an example of automatic turn-on function.

### Latched and Autoretry Fault Management

The MAX5930 can be configured to either latch the external MOSFETs off or to autoretry (see Table 2). Toggling ON\_ below 0.875V for at least 100µs clears the MAX5930/MAX5931 (LATCH = FLOAT) fault and reinitiates the startup period. Similarly, the MAX5930/MAX5931 (LATCH = GND) turn the external MOSFETs off when an overcurrent fault is detected, then automatically restart after the autoretry delay that is internally set to 64 times  $t_{START}$ .

### Status Outputs (STAT\_)

The status (STAT\_) outputs are open-drain outputs that assert when hot swap is successful and  $t_{START}$  has elapsed. STAT\_ deasserts if ON\_ is low or if the channel is turned off for any fault condition.

The polarity of the STAT\_ outputs is selected using POL for the MAX5930 (see Table 3). Tables 4 and 5 contain the MAX5930/MAX5931 truth tables.

# Low-Voltage, Triple, Hot-Swap Controllers/ Power Sequencers/Voltage Trackers

**Table 2. Selecting Fault-Management Mode (MAX5930)**

LATCH	FAULT MANAGEMENT
Floating	Fault condition latches MOSFETs off
Low	Autoretry mode

**Table 3. Selecting STAT\_ Polarity (MAX5930)**

POL	STAT_
Low	Asserts low
Floating	Asserts high (open-drain)

## Applications Information

### Component Selection

#### N-Channel MOSFETs

Select the external MOSFETs according to the application's current levels. Table 6 lists recommended components. The MOSFET's on-resistance ( $R_{DS(ON)}$ ) should be chosen low enough to have a minimum voltage drop at full load to limit the MOSFET power dissipation. High  $R_{DS(ON)}$  causes output ripple if there is a pulsating load. Determine the device power rating to accommodate a short-circuit condition on the board at startup and when the device is in autoretry mode (see the *MOSFET Thermal Considerations* section).

Using these devices in latched mode allows the use of MOSFETs with lower power ratings. A MOSFET typically withstands single-shot pulses with higher dissipation than the specified package rating. Table 7 lists some recommended MOSFET manufacturers.

#### Sense Resistor

The slow-comparator threshold voltage is adjustable from 25mV to 100mV. Select a sense resistor that causes a drop equal to the slow-comparator threshold voltage at a current level above the maximum normal operating current. Typically, set the overload current at 1.2 to 1.5 times the full load current. The fast-comparator threshold is two times the slow-comparator threshold in normal operating mode. Choose the sense-resistor power rating to be greater than or equal to  $2 \times (I_{OVERLOAD}) \times V_{SC,TH}$ . Table 7 lists some recommended sense-resistor manufacturers.

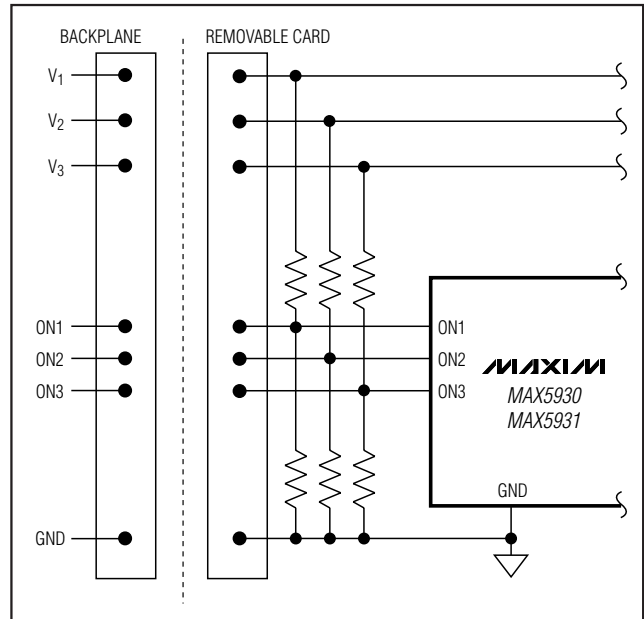

Figure 8. Automatic Turn-On When Input Voltages are Above their Respective Undervoltage Lockout Threshold (Provided  $t_{D,UVLO}$  Requirement is Met)

#### Slow-Comparator Threshold, $R_{LIM}$ (MAX5930)

The slow-comparator threshold voltage is adjustable from 25mV to 100mV, allowing designers to fine-tune the current-limit threshold for use with standard-value sense resistors. Low slow-comparator thresholds allow for increased efficiency by reducing the power dissipated by the sense resistor. Furthermore, the low 25mV slow-comparator threshold is beneficial when operating with supply rails down to 1V because it allows a small percentage of the overall output voltage to be used for current sensing. The VariableSpeed/BiLevel fault protection feature offers inherent system immunity against load transients and noise. This allows the slow-comparator threshold to be set close to the maximum normal operating level without experiencing nuisance faults. To adjust the slow-comparator threshold, calculate  $R_{LIM}$  as follows:

$$R_{LIM} = \frac{V_{TH} - 25mV}{7.5\mu A}$$

where  $V_{TH}$  is the desired slow-comparator threshold voltage. Shorting  $LIM_+$  to GND sets  $V_{TH}$  to 25mV. **Do not leave  $LIM_+$  open.**

# Low-Voltage, Triple, Hot-Swap Controllers/ Power Sequencers/Voltage Trackers

MAX5930/MAX5931

**Table 4. Status Output Truth Table: Voltage-Tracking and Power-Sequencing Modes**

PART	CHANNEL 1 FAULT	CHANNEL 2 FAULT	CHANNEL 3 FAULT	STAT1/ GATE1*	STAT2/ GATE2*	STAT3/ GATE3*
MAX5930 (POL = 1), MAX5931H	Yes	X	X	L/OFF	L/OFF	L/OFF
	X	Yes	X	L/OFF	L/OFF	L/OFF
	X	X	Yes	L/OFF	L/OFF	L/OFF
	X	X	X	L/OFF	L/OFF	L/OFF
	No	No	No	H/ON	H/ON	H/ON
MAX5930 (POL = 0), MAX5931L	Yes	X	X	H/OFF	H/OFF	H/OFF
	X	Yes	X	H/OFF	H/OFF	H/OFF
	X	X	Yes	H/OFF	H/OFF	H/OFF
	X	X	X	H/OFF	H/OFF	H/OFF
	No	No	No	L/ON	L/ON	L/ON

\*L = Low, H = High.

**Table 5. Status Output Truth Table: Independent Mode**

CHANNEL 1 FAULT	CHANNEL 2 FAULT	CHANNEL 3 FAULT	STAT1/ GATE1	STAT2/ GATE2	STAT3/ GATE3
Yes	Yes	Yes	Unasserted/OFF	Unasserted/OFF	Unasserted/OFF
Yes	Yes	No	Unasserted/OFF	Unasserted/OFF	Asserted/ON
Yes	No	Yes	Unasserted/OFF	Asserted/ON	Unasserted/OFF
Yes	No	No	Unasserted/OFF	Asserted/ON	Asserted/ON
No	Yes	Yes	Asserted/ON	Unasserted/OFF	Unasserted/OFF
No	Yes	No	Asserted/ON	Unasserted/OFF	Asserted/ON
No	No	Yes	Asserted/ON	Asserted/ON	Unasserted/OFF
No	No	No	Asserted/ON	Asserted/ON	Asserted/ON

**Note:** STAT<sub>n</sub> is asserted when hot swap is successful and t<sub>ON</sub> has elapsed. STAT<sub>n</sub> is unasserted during a fault.

**Table 6. Recommended N-Channel MOSFETs**

PART NUMBER	MANUFACTURER	DESCRIPTION
IRF7413	International Rectifier	11mΩ, 8-pin SO, 30V
IRF7401		22mΩ, 8-pin SO, 20V
IRL3502S		6mΩ, D <sup>2</sup> PAK, 20V
MMSF3300	Motorola	20mΩ, 8-pin SO, 30V
MMSF5N02H		30mΩ, 8-pin SO, 20V
MTB60N05H		14mΩ, D <sup>2</sup> PAK, 50V
FDS6670A	Fairchild	10mΩ, 8-pin SO, 30V
ND8426A		13.5mΩ, 8-pin SO, 20V
FDB8030L		4.5mΩ, D <sup>2</sup> PAK, 30V

# Low-Voltage, Triple, Hot-Swap Controllers/ Power Sequencers/Voltage Trackers

Table 7. Component Manufacturers

COMPONENT	MANUFACTURER	PHONE	WEBSITE
Sense Resistors	Dale-Vishay	402-562-3131	www.vishay.com
	IRC	704-264-8861	www.irctt.com
MOSFETs	Fairchild	888-522-5372	www.fairchildsemi.com
	International Rectifier	310-233-3331	www.irf.com
	Motorola	602-224-3576	www.mot-sps.com/ppd

### Setting the Startup Period, $R_{TIM}$

The startup period ( $t_{START}$ ) is adjustable from 0.4ms to 50ms. The adjustable startup period feature allows systems to be customized for MOSFET gate capacitance and board capacitance ( $C_{BOARD}$ ). The startup period is adjusted with a resistor connected from TIM to GND ( $R_{TIM}$ ).  $R_{TIM}$  must be between 4k $\Omega$  and 500k $\Omega$ . The startup period has a default value of 9ms when TIM is left floating. Calculate  $R_{TIM}$  with the following equation:

$$R_{TIM} = \frac{t_{START}}{128 \times 800\text{pF}}$$

where  $t_{START}$  is the desired startup period.

### Startup Sequence

There are two ways of completing the startup sequence. **Case A** describes a startup sequence that slowly turns on the MOSFETs by limiting the gate charge. **Case B** uses the current-limiting feature and turns on the MOSFETs as fast as possible while still preventing a high inrush current. The output voltage ramp-up time ( $t_{ON}$ ) is determined by the longer of the two timings, case A and case B. Set the startup timer ( $t_{START}$ ) to be longer than  $t_{ON}$  to guarantee enough time for the output voltage to settle.

#### Case A: Slow Turn-On (Without Current Limit)

There are two ways to turn on the MOSFETs without reaching the fast-comparator current limit:

- If the board capacitance ( $C_{BOARD}$ ) is small, the inrush current is low.
- If the gate capacitance is high, the MOSFETs turn on slowly.

In both cases, the turn-on time is determined only by the charge required to enhance the MOSFET. The small 100 $\mu$ A gate-charging current effectively limits the output voltage  $dV/dt$ . Connecting an external capacitor between GATE and GND extends the turn-on time. The time required to charge/discharge a MOSFET is as follows:

$$t = \frac{C_{GATE} \times \Delta V_{GATE} + Q_{GATE}}{I_{GATE}}$$

where:

$C_{GATE}$  is the external gate to ground capacitance (Figure 9),

$\Delta V_{GATE}$  is the change in gate charge,

$Q_{GATE}$  is the MOSFET total gate charge,

$I_{GATE}$  is the gate-charging/discharging current.

In this case, the inrush current depends on the MOSFET gate-to-drain capacitance ( $C_{RSS}$ ) plus any additional capacitance from GATE to GND ( $C_{GATE}$ ), and on any load current ( $I_{LOAD}$ ) present during the startup period.

$$I_{INRUSH} = \frac{C_{BOARD}}{C_{RSS} + C_{GATE}} \times I_{GATE} + I_{LOAD}$$

#### Example: Charging and discharging times using the Fairchild FDB7030L MOSFET

If  $V_{IN1} = 5V$  then GATE1 charges up to 10.4V ( $V_{IN1} + V_{DRIVE}$ ), therefore  $\Delta V_{GATE} = 10.4V$ . The manufacturer's data sheet specifies that the FDB7030L has approximately 60nC of gate charge and  $C_{RSS} = 600\text{pF}$ . The MAX5930/MAX5931 have a 100 $\mu$ A gate charging current and a 3mA/50mA normal/strong discharging current.  $C_{BOARD} = 6\mu\text{F}$  and the load does not draw any current during the startup period. With no gate capacitor, the inrush current, charge, and discharge times are:

$$I_{INRUSH} = \frac{6\mu\text{F}}{600\text{pF} + 0} \times 100\mu\text{A} + 0 = 1A$$

$$t_{CHARGE} = \frac{0 \times 10.4V + 60\text{nC}}{100\mu\text{A}} = 0.6\text{ms}$$

$$t_{DISCHARGE(NORMAL)} = \frac{0 \times 10.4V + 60\text{nC}}{3\text{mA}} = 0.02\text{ms}$$

$$t_{DISCHARGE(STRONG)} = \frac{0 \times 10.4V + 60\text{nC}}{50\text{mA}} = 1.2\mu\text{s}$$

# Low-Voltage, Triple, Hot-Swap Controllers/ Power Sequencers/Voltage Trackers

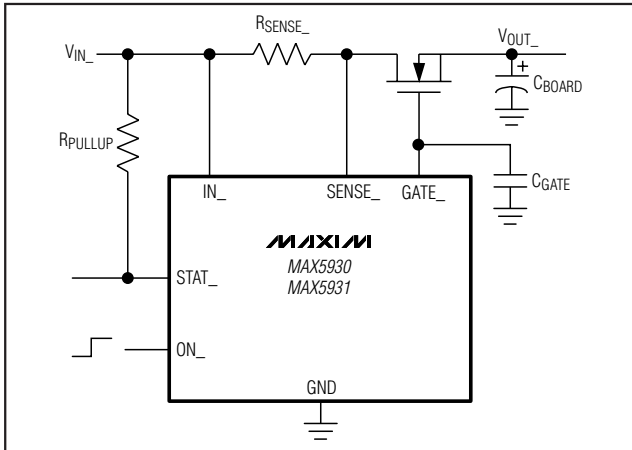

Figure 9. Operating with an External Gate Capacitor

With a 22nF gate capacitor, the inrush current, charge, and discharge times are:

$$I_{\text{INRUSH}} = \frac{6\mu\text{F}}{600\text{pF} + 22\text{nF}} \times 100\mu\text{A} + 0 = 26.5\text{mA}$$

$$t_{\text{CHARGE}} = \frac{22\text{nF} \times 10.4\text{V} + 60\text{nC}}{100\mu\text{A}} = 2.89\text{ms}$$

$$t_{\text{DISCHARGE(NORMAL)}} = \frac{22\text{nF} \times 10.4\text{V} + 60\text{nC}}{3\text{mA}} = 0.096\text{ms}$$

$$t_{\text{DISCHARGE(STRONG)}} = \frac{22\text{nF} \times 10.4\text{V} + 60\text{nC}}{50\text{mA}} = 5.8\mu\text{s}$$

## Case B: Fast Turn-On (With Current Limit)

In applications where the board capacitance ( $C_{\text{BOARD}}$ ) is high, the inrush current causes a voltage drop across  $R_{\text{SENSE}}$  that exceeds the startup fast-comparator threshold. The fast comparator regulates the voltage across the sense resistor to  $V_{\text{FC,TH}}$ . This effectively regulates the inrush current during startup. In this case, the current charging  $C_{\text{BOARD}}$  can be considered constant and the turn-on time is:

$$t_{\text{ON}} = \frac{C_{\text{BOARD}} \times V_{\text{IN}} \times R_{\text{SENSE}}}{V_{\text{FC,TH}}}$$

The maximum inrush current in this case is:

$$I_{\text{INRUSH}} = \frac{V_{\text{FC,TH}}}{R_{\text{SENSE}}}$$

Figure 6 shows the waveforms and timing diagrams for a startup transient with current regulation (see the *Typical Operating Characteristics*). **When operating**

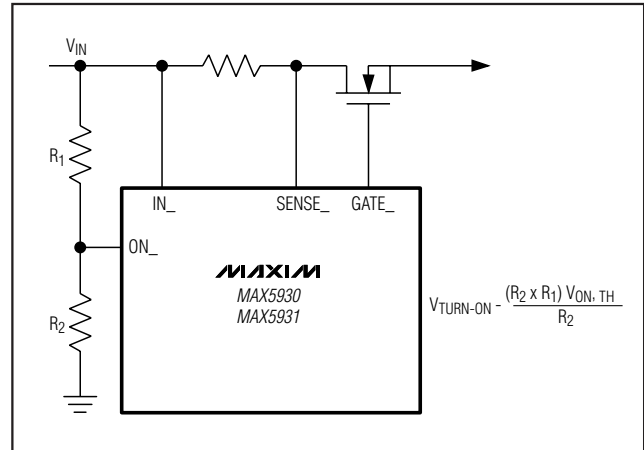

Figure 10. Adjustable Undervoltage Lockout

**under this condition, an external gate capacitor is not required.**

## ON Comparators

The ON comparators control the on/off function of the MAX5930/MAX5931. ON\_ is also used to reset the fault latch (latch mode). Pull  $V_{\text{ON}}$  low for 100 $\mu\text{s}$ ,  $t_{\text{UNLATCH}}$ , to reset the shutdown latch. ON\_ also programs the UVLO threshold (see Figure 10). A resistive-divider between  $V_{\text{IN}}$ ,  $V_{\text{ON}}$ , and GND sets the user-programmable turn-on voltage. In power-sequencing mode, an RC circuit can be used at ON\_ to set the delay timing (see Figure 11).

## Using the MAX5930/MAX5931 on the Backplane

Using the MAX5930/MAX5931 on the backplane allows multiple cards with different input capacitance to be inserted into the same slot even if the card does not have on-board hot-swap protection. The startup period can be triggered if IN\_ is connected to ON\_ through a trace on the card (Figure 12).

## Input Transients

The voltage at IN1, IN2, or IN3 must be above  $V_{\text{UVLO}}$  during inrush and fault conditions. When a short-circuit condition occurs on the board, the fast-comparator trips cause the external MOSFET gates to be discharged at 50mA according to the mode of operation (see the *Mode* section). The main system power supply must be able to sustain a temporary fault current, without dropping below the UVLO threshold of 2.45V, until the external MOSFET is completely off. If the main system power supply collapses below UVLO, the MAX5930/MAX5931 force the device to restart once the supply has recovered. The MOSFET is turned off in a very short time resulting in a high di/dt. The

# Low-Voltage, Triple, Hot-Swap Controllers/ Power Sequencers/Voltage Trackers

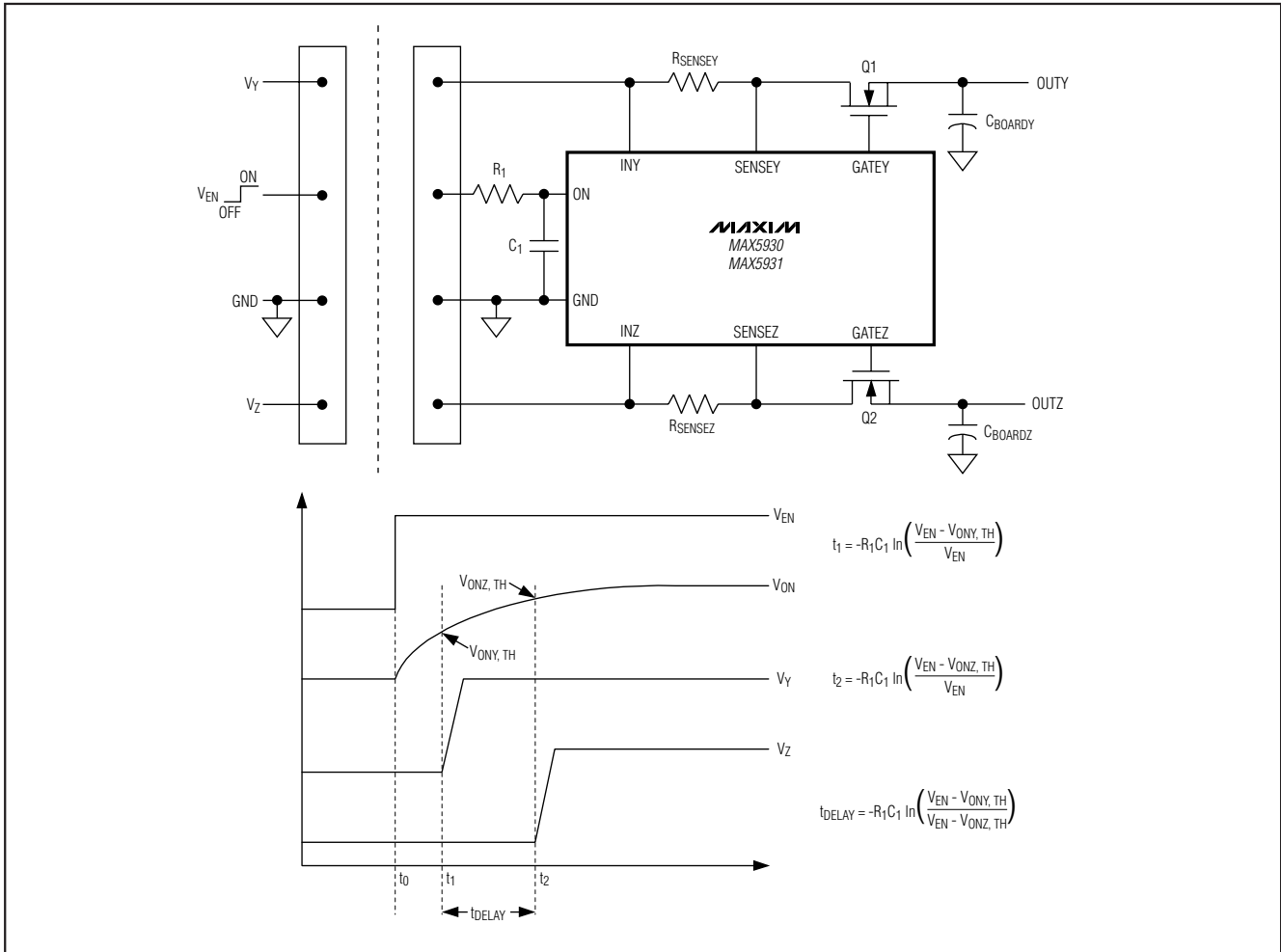

Figure 11. Power Sequencing: Channel Z Turns On  $t_{DELAY}$  After Channel Y

backplane delivering the power to the external card must have low inductance to minimize voltage transients caused by this high di/dt.

### MOSFET Thermal Considerations

During normal operation, the external MOSFETs dissipate little power. The MOSFET  $R_{DS(ON)}$  is low when the MOSFET is fully enhanced. The power dissipated in normal operation is  $P_D = I_{LOAD}^2 \times R_{DS(ON)}$ . The most power dissipation occurs during the turn-on and turn-off transients when the MOSFETs are in their linear regions. By taking into consideration the worst-case scenario of a continuous short-circuit fault, consider these two cases:

1) The single turn-on with the device latched after a fault: MAX5930/MAX5931 (LATCH = high or floating).

2) The continuous autoretry after a fault: MAX5930/MAX5931 (LATCH = low).

MOSFET manufacturers typically include the package thermal resistance from junction to ambient ( $R_{\theta JA}$ ) and thermal resistance from junction to case ( $R_{\theta JC}$ ), which determine the startup time and the retry duty cycle ( $d = t_{START}/(t_{START} + t_{RETRY})$ ). Calculate the required transient thermal resistance with the following equation:

$$Z_{\theta JA(MAX)} \leq \frac{T_{JMAX} - T_A}{V_{IN} \times I_{START}}$$

where  $I_{START} = V_{SU,TH}/R_{SENSE}$ .

# Low-Voltage, Triple, Hot-Swap Controllers/ Power Sequencers/Voltage Trackers

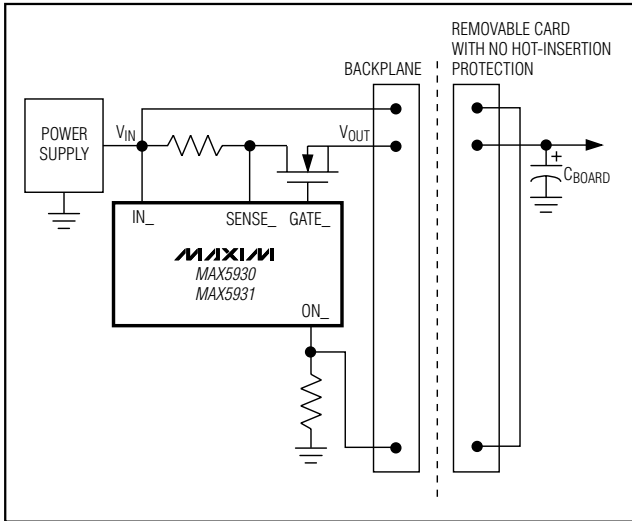

Figure 12. Using the MAX5930/MAX5931 on a Backplane

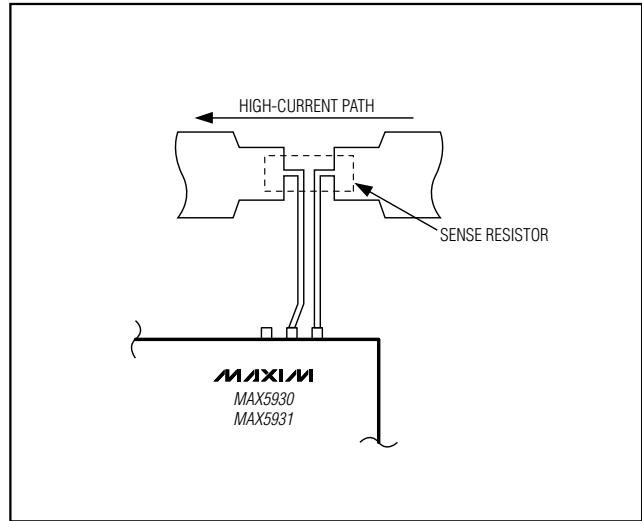

Figure 13. Kelvin Connection for the Current-Sense Resistors

## Layout Considerations

To take full tracking advantage of the switch response time to an output fault condition, it is important to keep all traces as short as possible and to maximize the high-current trace dimensions to reduce the effect of undesirable parasitic inductance. Place the MAX5930/MAX5931 close to the card's connector. Use a ground plane to minimize impedance and inductance. Minimize the current-sense resistor trace length (<10mm), and ensure accurate current sensing with Kelvin connections (Figure 13).

When the output is short circuited, the voltage drop across the external MOSFET becomes large. Hence, the power dissipation across the switch increases, as does the die temperature. An efficient way to achieve good power dissipation on a surface-mount package is to lay out two copper pads directly under the MOSFET package on both sides of the board. Connect the two pads to the ground plane through vias, and use enlarged copper mounting pads on the topside of the board.

## Pin Configurations (continued)

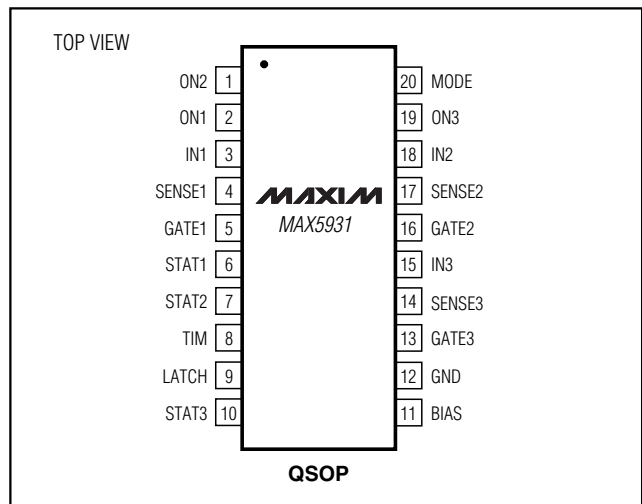

# Low-Voltage, Triple, Hot-Swap Controllers/ Power Sequencers/Voltage Trackers

## Typical Operating Circuit

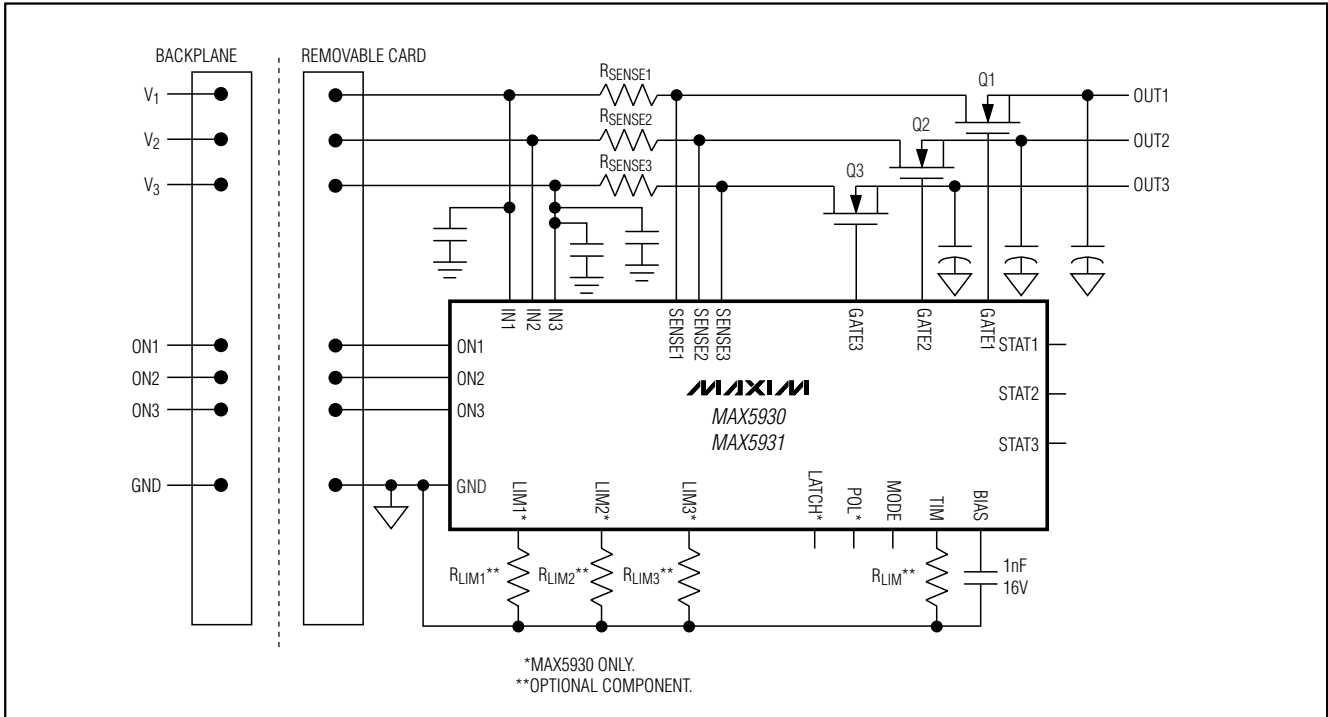

## Selector Guide

PART	CURRENT LIMIT	FAULT MANAGEMENT	STAT_ POLARITY
MAX5930EEG	Programmable	Selectable	Selectable
MAX5931LEEP	Fixed	Selectable	Asserted Low
MAX5931HEEP	Fixed	Selectable	Asserted High (Open-Drain)

## Chip Information

TRANSISTOR COUNT: 7704  
PROCESS: BiCMOS

# Low-Voltage, Triple, Hot-Swap Controllers/ Power Sequencers/Voltage Trackers

## Package Information

(The package drawing(s) in this data sheet may not reflect the most current specifications. For the latest package outline information, go to [www.maxim-ic.com/packages](http://www.maxim-ic.com/packages).)

MAX5930/MAX5931

QSOP-EPS

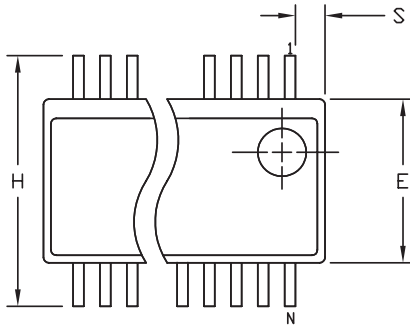

DIM	INCHES		MILLIMETERS	
	MIN	MAX	MIN	MAX
A	.061	.068	1.55	1.73
A1	.004	.0098	0.102	0.249
A2	.055	.061	1.40	1.55
B	.008	.012	0.20	0.30
C	.0075	.0098	0.191	0.249
D	SEE VARIATIONS			
E	.150	.157	3.81	3.99
e	.025 BSC		0.635 BSC	
H	.230	.244	5.84	6.20
h	.010	.016	0.25	0.41
L	.016	.035	0.41	0.89
N	SEE VARIATIONS			
$\alpha$	0°	8°	0°	8°

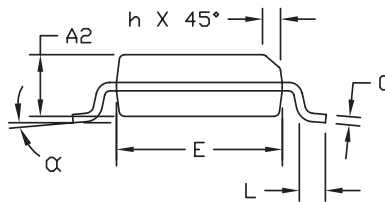
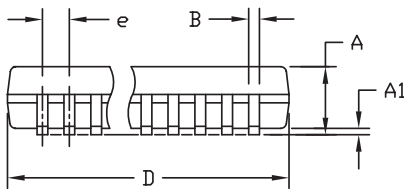

### VARIATIONS:

DIM	INCHES		MILLIMETERS		N
	MIN.	MAX.	MIN.	MAX.	
D	.189	.196	4.80	4.98	16 AB
S	.0020	.0070	0.05	0.18	
D	.337	.344	8.56	8.74	20 AD
S	.0500	.0550	1.270	1.397	
D	.337	.344	8.56	8.74	24 AE
S	.0250	.0300	0.635	0.762	
D	.386	.393	9.80	9.98	28 AF
S	.0250	.0300	0.635	0.762	

### NOTES:

- 1). D & E DO NOT INCLUDE MOLD FLASH OR PROTRUSIONS.
- 2). MOLD FLASH OR PROTRUSIONS NOT TO EXCEED .006" PER SIDE.
- 3). CONTROLLING DIMENSIONS: INCHES.
- 4). MEETS JEDEC MO137.

	<b>DALLAS SEMICONDUCTOR</b> <small>PROPRIETARY INFORMATION</small>		<b>MAXIM</b>	
	<small>TITLE:</small> PACKAGE OUTLINE, QSOP .150", .025" LEAD PITCH			
<small>APPROVAL</small>	<small>DOCUMENT CONTROL NO.</small> 21-0055	<small>REV.</small> E	<small>1/1</small>	

Maxim cannot assume responsibility for use of any circuitry other than circuitry entirely embodied in a Maxim product. No circuit patent licenses are implied. Maxim reserves the right to change the circuitry and specifications without notice at any time.

Maxim Integrated Products, 120 San Gabriel Drive, Sunnyvale, CA 94086 408-737-7600 \_\_\_\_\_ 23

## Looking for pricing, stock, or lifecycle information?

Click below to explore more details on WIN SOURCE:

- ⊖ [View MAX5930EEG+ on WIN SOURCE](#)
- ⊖ [Maxim Integrated Information](#)

## Optimize Your Supply Chain with WIN SOURCE Solutions

- ✓ Global Sourcing Solution
- ✓ Obsolete Management
- ✓ Cost Control Management
- ✓ Shortage Management
- ✓ Alternative Solution
- ✓ Excess Inventory Management