



**THE DATASHEET OF
MAX5318GUG+**



MAX5318

18-Bit, High-Accuracy Voltage Output DAC with Digital Gain, Offset Control, and SPI Interface

General Description

The MAX5318 is a high-accuracy, 18-bit, serial SPI input, buffered voltage output digital-to-analog converter (DAC) in a 4.4mm x 7.8mm, 24-lead TSSOP package. The device features ± 2 LSB INL (max) accuracy and a ± 1 LSB DNL (max) accuracy over the full temperature range of -40°C to $+105^{\circ}\text{C}$.

The DAC voltage output is buffered resulting in a fast settling time of $3\mu\text{s}$ and a low offset and gain drift of $\pm 0.5\text{ppm}/^{\circ}\text{C}$ of FSR (typ). The force-sense output (OUT) maintains accuracy while driving loads with long lead lengths. Additionally, a separate AVSS supply, allows the output amplifier to go to 0V (GND) while maintaining full linearity performance.

The MAX5318 includes user-programmable digital gain and offset correction to enable easy system calibration.

At power-up, the device resets its outputs to zero or mid-scale. The wide 2.7V to 5.5V supply voltage range and integrated low-drift, low-noise reference buffer amplifier make for ease of use.

The MAX5318 features a 50MHz 3-wire SPI interface. The MAX5318 is available in a 24-lead TSSOP package and operates over the -40°C to $+105^{\circ}\text{C}$ temperature range.

Applications

Test and Measurement Equipment	Programmable Voltage and Current Sources
Automatic Test Equipment	Automatic Tuning and Calibration
Gain and Offset Adjustment	Communication Systems
Data-Acquisition Systems	Medical Imaging
Process Control and Servo Loops	

For related parts and recommended products to use with this part, refer to www.maximintegrated.com/MAX5318.related.

Benefits and Features

- ◆ **Ideal for ATE and High-Precision Instruments**
 - ◇ INL Accuracy Guaranteed with ± 2 LSB (Max) Over Temperature
- ◆ **Fast Settling Time ($3\mu\text{s}$) with $10\text{k}\Omega$ || 100pF Load**
- ◆ **Safe Power-Up-Reset to Zero or Midscale DAC Output (Pin-Selectable)**
 - ◇ Predetermined Output Device State in Power-Up and Reset in System Design
- ◆ **Negative Supply (AVSS) Option Allows Full INL and DNL Performance to 0V**
- ◆ **SPI Interface Compatible with 1.8V to 5.5V Logic**
- ◆ **High Integration Reduces Development Time and PCB Area**
 - ◇ Buffered Voltage Output Directly Drives $2\text{k}\Omega$ Load Rail-to-Rail
 - ◇ Integrated Reference Buffer
 - ◇ No External Amplifiers Required
- ◆ **Small 4.4mm x 7.8mm, 24-Pin TSSOP Package**

Ordering Information and Typical Operating Circuit appear at end of data sheet.

Functional Diagram

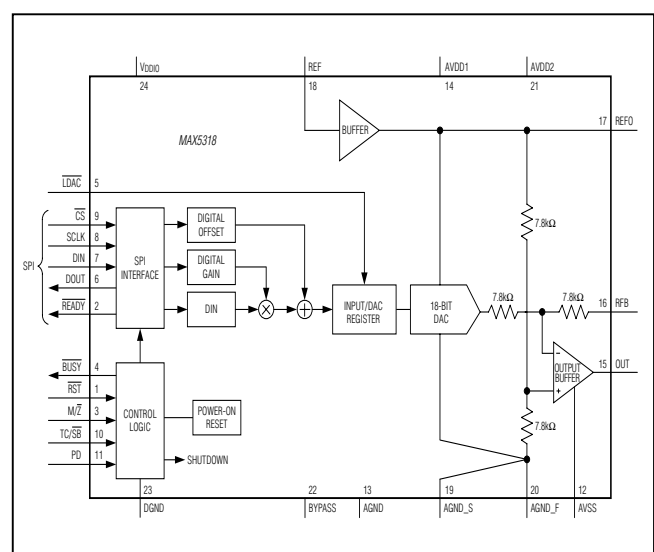

For pricing, delivery, and ordering information, please contact Maxim Direct at 1-888-629-4642, or visit Maxim's website at www.maximintegrated.com.

MAX5318

18-Bit, High-Accuracy Voltage Output DAC with Digital Gain, Offset Control, and SPI Interface

ABSOLUTE MAXIMUM RATINGS

AGND to DGND	-0.3V to +0.3V	REF to AGND	-0.3V to the lower of V_{AVDD} and +6V
AGND_F, AGND_S to AGND	-0.3V to +0.3V	SCLK, DIN, \overline{CS} , \overline{BUSY} , LDAC, READY,	
AGND_F, AGND_S to DGND	-0.3V to +0.3V	$\overline{M/Z}$, TC/ \overline{SB} , \overline{RST} , PD, DOUT to DGND.....	-0.3V to the lower of
AVDD to AGND	-0.3V to +6V		($V_{DDIO} + 0.3V$) and +6V
AVDD to REF	-0.3V to +6V	Continuous Power Dissipation ($T_A = +70^\circ\text{C}$)	
AVSS to AGND	-2V to +0.3V	TSSOP (derate 13.9mW/ $^\circ\text{C}$ above +70 $^\circ\text{C}$).....	1111.1mW
V_{DDIO} to DGND.....	-0.3V to +6V	Operating Temperature Range	-40 $^\circ\text{C}$ to +105 $^\circ\text{C}$
BYPASS to DGND	-0.3V to the lower of	Maximum Junction Temperature.....	+150 $^\circ\text{C}$
	(V_{AVDD} or $V_{DDIO} + 0.3V$) and +4.5V	Storage Temperature Range.....	-65 $^\circ\text{C}$ to +150 $^\circ\text{C}$
OUT, REFO, RFB to AGND	-0.3V to the lower of	Lead Temperature (soldering, 10s)	+300 $^\circ\text{C}$
	($V_{AVDD} + 0.3V$) and +6V	Soldering Temperature (reflow)	+260 $^\circ\text{C}$

Stresses beyond those listed under "Absolute Maximum Ratings" may cause permanent damage to the device. These are stress ratings only, and functional operation of the device at these or any other conditions beyond those indicated in the operational sections of the specifications is not implied. Exposure to absolute maximum rating conditions for extended periods may affect device reliability.

PACKAGE THERMAL CHARACTERISTICS (Note 1)

TSSOP

Junction-to-Case Thermal Resistance (θ_{JA})	13 $^\circ\text{C}/\text{W}$
Junction-to-Ambient Thermal Resistance (θ_{JA})	72 $^\circ\text{C}/\text{W}$

Note 1: Package thermal resistances were obtained using the method described in JEDEC specification JESD51-7, using a four-layer board. For detailed information on package thermal considerations, refer to www.maximintegrated.com/thermal-tutorial.

ELECTRICAL CHARACTERISTICS

($V_{AVDD} = V_{DDIO} = 4.5V$ to $5.5V$, $V_{AVSS} = -1.25V$, $V_{AGND} = V_{DGND} = V_{AGND_F} = V_{AGND_S} = 0V$, $V_{REF} = 4.096V$, TC/ $\overline{SB} = PD = \overline{LDAC} = \overline{M/Z} = DGND$, $\overline{RST} = V_{DDIO}$, $C_{REFO} = 100pF$, $C_L = 100pF$, $R_L = 10k\Omega$, $C_{BYPASS} = 1\mu F$, $T_A = -40^\circ\text{C}$ to +105 $^\circ\text{C}$, unless otherwise noted. Typical values are at $T_A = +25^\circ\text{C}$.) (GAIN = 0x3FFFF and OFFSET = 0x00000.)(Note 2)

PARAMETER	SYMBOL	CONDITIONS	MIN	TYP	MAX	UNITS
STATIC PERFORMANCE						
Resolution	N		18			Bits
Integral Nonlinearity (Note 3)	INL	DIN = 0x00000 to 0x3FFFF (binary mode), DIN = 0x20000 to 0x1FFFF (two's complement mode)	-2	± 0.5	+2	LSB
		DIN = 0x01900 to 0x3FFFF (binary mode), DIN = 0x21900 to 0x1FFFF (two's complement mode), $V_{AVSS} = 0V$				
Differential Nonlinearity (Note 3)	DNL		-1	± 0.275	+1	LSB
Zero Code Error	OE	DIN = 0, $T_A = +25^\circ\text{C}$	-48	± 4	+48	LSB
		DIN = 0, $T_A = -40^\circ\text{C}$ to +105 $^\circ\text{C}$		± 14		
Zero Code Error Drift (Note 4)		DIN = 0	-1.6	± 0.10	+1.6	ppm/ $^\circ\text{C}$
Gain Error	GE	$T_A = +25^\circ\text{C}$	-16	± 1	+16	LSB
		$T_A = -40^\circ\text{C}$ to +105 $^\circ\text{C}$		± 27		
Gain Error Temperature Coefficient (Note 4)	TCGE		-2.5	± 0.10	+2.5	ppm/ $^\circ\text{C}$ of FSR
Output Voltage Range		No load	0		$V_{AVDD} - 0.1$	V

MAX5318

18-Bit, High-Accuracy Voltage Output DAC with Digital Gain, Offset Control, and SPI Interface

ELECTRICAL CHARACTERISTICS (continued)

($V_{AVDD} = V_{DDIO} = 4.5V$ to $5.5V$, $V_{AVSS} = -1.25V$, $V_{AGND} = V_{DGND} = V_{AGND_F} = V_{AGND_S} = 0V$, $V_{REF} = 4.096V$, $TC/\overline{SB} = PD = \overline{LDAC} = \overline{M/\overline{Z}} = DGND$, $\overline{RST} = V_{DDIO}$, $C_{REF0} = 100pF$, $C_L = 100pF$, $R_L = 10k\Omega$, $C_{BYPASS} = 1\mu F$, $T_A = -40^\circ C$ to $+105^\circ C$, unless otherwise noted. Typical values are at $T_A = +25^\circ C$.) (GAIN = 0x3FFFF and OFFSET = 0x00000.)(Note 2)

PARAMETER	SYMBOL	CONDITIONS	MIN	TYP	MAX	UNITS
Reset Voltage Output	$V_{OUT-RESET}$	$\overline{RST} = \text{pulse low}$	$\overline{M/\overline{Z}} = DGND$		75	μV
			$\overline{M/\overline{Z}} = V_{DDIO}$		2.048	V
		$\overline{RST} = \text{pulse low}, V_{AVSS} = 0V$	$\overline{M/\overline{Z}} = DGND$		10	mV
			$\overline{M/\overline{Z}} = V_{DDIO}$		2.048	V
		$\overline{RST} = DGND$	$\overline{M/\overline{Z}} = DGND$		-68	mV
			$\overline{M/\overline{Z}} = V_{DDIO}$		2.036	V
DC Output Impedance (Normal Mode)	R_{OUT}	Closed-loop connection (RFB connected to OUT)	$\overline{M/\overline{Z}} = DGND$		4	$m\Omega$
			$\overline{M/\overline{Z}} = V_{DDIO}$		2.036	V
Output Resistance (Power-Down Mode)		$PD = V_{DDIO}$		2	$k\Omega$	
Output Current	I_{OUT}	Source/sink within 100mV of the supply rails		± 4	mA	
		Source/sink within 800mV of the supply rails		± 25		
Load Capacitance to GND	C_L				200	pF
Load Resistance to GND	R_L	For specified performance	2			$k\Omega$
Short-Circuit Current	I_{SC}	OUT shorted to AGND or AVDD		± 60	mA	
		REFO shorted to AGND or AVDD		± 65		
		BYPASS shorted to AGND or AVDD		± 48		
Short-Circuit Duration	T_{SC}	Short to AGND or AVDD		Indefinite		s
DC Power-Supply Rejection	DC PSRR	V_{OUT} at full scale, $V_{AVDD} = 4.5V$ to $5.5V$	-2.5	± 0.20	+2.5	LSB/V
		$V_{AVSS} = -1.5V$ to $-0.5V$	-2.5	± 0.12	+2.5	
STATIC PERFORMANCE—VOLTAGE REFERENCE INPUT SECTION						
Reference High Input Range	V_{REF}		2.4		$V_{AVDD} - 0.1$	V
Reference Input Capacitance	C_{REF}			10		pF
Reference Input Resistance	R_{REF}			10		$M\Omega$
Reference Input Current	I_B			± 0.15		μA
STATIC PERFORMANCE—VOLTAGE REFERENCE OUTPUT SECTION						
Reference High Output Range			2.4		$V_{AVDD} - 0.1$	V
Reference High Output Load Regulation				500		ppm/ mA
Reference Output Capacitor		$R_{ESR} < 5\Omega$		0.1		nF

MAX5318

18-Bit, High-Accuracy Voltage Output DAC with Digital Gain, Offset Control, and SPI Interface

ELECTRICAL CHARACTERISTICS (continued)

($V_{AVDD} = V_{DDIO} = 4.5V$ to $5.5V$, $V_{AVSS} = -1.25V$, $V_{AGND} = V_{DGND} = V_{AGND_F} = V_{AGND_S} = 0V$, $V_{REF} = 4.096V$, $TC/\overline{SB} = PD = \overline{LDAC} = \overline{M/\overline{Z}} = DGND$, $\overline{RST} = V_{DDIO}$, $C_{REF0} = 100pF$, $C_L = 100pF$, $R_L = 10k\Omega$, $C_{BYPASS} = 1\mu F$, $T_A = -40^\circ C$ to $+105^\circ C$, unless otherwise noted. Typical values are at $T_A = +25^\circ C$.) (GAIN = 0x3FFFF and OFFSET = 0x00000.)(Note 2)

PARAMETER	SYMBOL	CONDITIONS	MIN	TYP	MAX	UNITS
STATIC PERFORMANCE—V_{BYPASS} OUT SECTION						
Output Voltage	V_{BYPASS}		2.3	2.4	2.5	V
Load Capacitance to GND	C_L	Required for stability, $R_{ESR} = 0.1\Omega$ (typ)	1		8	μF
POWER-SUPPLY REQUIREMENTS						
Positive Analog Power-Supply Range	V_{AVDD}		4.5		5.5	V
Digital Interface Power-Supply Range	V_{DDIO}		1.8		V_{AVDD}	V
Negative Analog Power-Supply Range	V_{AVSS}		-1.5	-1.25	0	V
Positive Analog Power-Supply Current	I_{AVDD}	No load, external reference, output at zero scale		5.2	6.5	mA
Negative Analog Power-Supply Current	I_{AVSS}	No load, external reference, output at zero scale	-1.5	-1.0		mA
Interface Power-Supply Current	I_{VDDIO}	Digital inputs at V_{DDIO} or DGND		0.2	5.0	μA
Positive Analog Power-Supply Power-Down Current		$PD = V_{DDIO}$, power-down mode		20	50	μA
Negative Analog Power-Supply Power-Down Current		$PD = V_{DDIO}$, power-down mode	-5	-3		μA
DYNAMIC PERFORMANCE						
Voltage Output Slew Rate	SR	From 10% to 90% full scale, positive and negative transitions		4.9		V/ μs
Voltage Output Settling Time	t_S	From falling edge of LDAC to within 0.003% FS, $R_L = 10k\Omega$, DIN = 04000h (6.25% FS) to 3C000h (93.75% FS)		3		μs
Busy Time	t_{BUSY}	(Note 5)		1.9		μs
DAC Glitch Impulse		Major code transition (1FFFFh to 20000h), $R_L = 10k\Omega$, $C_L = 50pF$		4		nVs
Digital Feed Through		$CSB = V_{DDIO}$, $f_{SCLK} = 1kHz$, all digital inputs from 0V to V_{DDIO}		1		nVs
Output Voltage-Noise Spectral Density		At $f = 1kHz$ to $10kHz$, without reference, code = 20000h		26		nV/ \sqrt{Hz}
Output Voltage Noise		At $f = 0.1Hz$ to $10Hz$, without reference, code = 20000h		1.55		μV_{P-P}
Wake-Up Time		From power-down mode		75		μs
Power-Up Time		From power-off		2		ms

MAX5318

18-Bit, High-Accuracy Voltage Output DAC with Digital Gain, Offset Control, and SPI Interface

ELECTRICAL CHARACTERISTICS

($V_{AVDD} = V_{DDIO} = 2.7V$ to $3.3V$, $V_{AVSS} = -1.25V$, $V_{AGND} = V_{DGND} = V_{AGND_F} = V_{AGND_S} = 0V$, $V_{REF} = 2.5V$, $TC/\overline{SB} = PD = \overline{LDAC} = \overline{M/\overline{Z}} = DGND$, $\overline{RST} = V_{DDIO}$, $C_{REF0} = 100pF$, $C_L = 100pF$, $R_L = 10k\Omega$, $C_{BYPASS} = 1\mu F$, $GAIN = 0x3FFFF$, $OFFSET = 0x00000$, $T_A = -40^\circ C$ to $+105^\circ C$, unless otherwise noted. Typical values are at $T_A = +25^\circ C$.) ($GAIN = 0x3FFFF$ and $OFFSET = 0x00000$.) (Note 2)

PARAMETER	SYMBOL	CONDITIONS	MIN	TYP	MAX	UNITS
STATIC PERFORMANCE						
Resolution	N		18			Bits
Integral Nonlinearity (Note 3)	INL	DIN = 0x00000 to 0x3FFFF (binary mode), DIN = 0x20000 to 0x1FFFF (two's complement mode)	-2.0	±0.75	+2.0	LSB
		DIN = 0x01900 to 0x3FFFF (binary mode), DIN = 0x21900 to 0x1FFFF (two's complement mode), $V_{AVSS} = 0V$				
Differential Nonlinearity (Note 3)	DNL		-1.0	±0.3	+1.0	LSB
Zero Code Error	OE	DIN = 0, $T_A = +25^\circ C$	-50	±6	+50	LSB
		DIN = 0, $T_A = -40^\circ C$ to $+105^\circ C$		±25		
Zero Code Error Drift (Note 4)		DIN = 0	-2.7	±1.4	+2.7	ppm/°C
Gain Error	GE	$T_A = +25^\circ C$	-16	±1.5	+16	LSB
		$T_A = -40^\circ C$ to $+105^\circ C$		±35		
Gain Error Temperature Coefficient (Note 4)	TCGE		-3.2		+3.2	ppm/°C of FSR
Output Voltage Range		No load	0		$V_{AVDD} - 0.1$	V
Reset Voltage Output	$V_{OUT-RESET}$	$\overline{RST} = \text{pulse low}$	$\overline{M/\overline{Z}} = DGND$	75		μV
			$\overline{M/\overline{Z}} = V_{DDIO}$	1.25		V
		$\overline{RST} = \text{pulse low}, V_{AVSS} = 0V$	$\overline{M/\overline{Z}} = DGND$	10		mV
			$\overline{M/\overline{Z}} = V_{DDIO}$	1.25		V
		$\overline{RST} = DGND$	$\overline{M/\overline{Z}} = DGND$	-40		mV
			$\overline{M/\overline{Z}} = V_{DDIO}$	1.25		V
$\overline{RST} = DGND, V_{AVSS} = 0V$	$\overline{M/\overline{Z}} = DGND$	10		mV		
	$\overline{M/\overline{Z}} = V_{DDIO}$	1.24		V		
DC Output Impedance	R_{OUT}	Closed-loop connection, RFB connected to OUT		4		mΩ
Output Current	I_{OUT}	Source/sink within 100mV of the supply rails		±4		mA
		Source/sink within 800mV of the supply rails		±25		
Load Capacitance to GND	C_L				200	pF
Load Resistance to GND	R_L	For specified performance	2			kΩ
Short-Circuit Current	I_{SC}	OUT shorted to AGND or AVDD		±60		mA
		REF0 shorted to AGND or AVDD		±65		
		BYPASS shorted to AGND or AVDD		±48		
Short-Circuit Duration	t_{SC}	Short to AGND or AVDD		Indefinite		s

MAX5318

18-Bit, High-Accuracy Voltage Output DAC with Digital Gain, Offset Control, and SPI Interface

ELECTRICAL CHARACTERISTICS (continued)

($V_{AVDD} = V_{DDIO} = 2.7V$ to $3.3V$, $V_{AVSS} = -1.25V$, $V_{AGND} = V_{DGND} = V_{AGND_F} = V_{AGND_S} = 0V$, $V_{REF} = 2.5V$, $TC/SB = PD = \overline{LDAC} = \overline{M/Z} = DGND$, $\overline{RST} = V_{DDIO}$, $C_{REF0} = 100pF$, $C_L = 100pF$, $R_L = 10k\Omega$, $C_{BYPASS} = 1\mu F$, $GAIN = 0x3FFFF$, $OFFSET = 0x00000$, $T_A = -40^\circ C$ to $+105^\circ C$, unless otherwise noted. Typical values are at $T_A = +25^\circ C$.) ($GAIN = 0x3FFFF$ and $OFFSET = 0x00000$.) (Note 2)

PARAMETER	SYMBOL	CONDITIONS	MIN	TYP	MAX	UNITS
DC Power-Supply Rejection	DCPSRR	V_{OUT} at full scale, $V_{AVDD} = 2.7V$ to $3.3V$	-2.5	± 0.4	+2.5	LSB/V
		$V_{AVSS} = -1.5V$ to $-0.5V$	-2.5	± 0.04	+2.5	
STATIC PERFORMANCE—VOLTAGE REFERENCE INPUT SECTION						
Reference High Input Range	V_{REF}		2.4		$V_{AVDD} - 0.1$	V
Reference Input Capacitance	C_{REF}			10		pF
Reference Input Resistance	R_{REF}			10		M Ω
Reference Input Current	I_B			± 0.15		μA
STATIC PERFORMANCE—VOLTAGE REFERENCE OUTPUT SECTION						
Reference High Output Range			2.4		$V_{AVDD} - 0.1$	V
Reference High Output Load Regulation				500		ppm/mA
Reference Output Capacitor		$R_{ESR} < 5\Omega$		0.1		nF
STATIC PERFORMANCE—V_{BYPASS} OUT SECTION						
Output Voltage	V_{BYPASS}		2.3	2.4	2.5	V
Load Capacitance to GND	C_L	Required for stability, $R_{ESR} = 0.1\Omega$ (typ)	1		8	μF
POWER-SUPPLY REQUIREMENTS						
Positive Analog Power-Supply Range	V_{AVDD}		2.7		3.3	V
Interface Power-Supply Range	V_{DDIO}		1.8		5.5	V
Negative Analog Power-Supply Range	V_{AVSS}		-1.5	-1.25	0	V
Positive Analog Power-Supply Current	I_{AVDD}	No load, external reference, output at zero scale		5.0	6.5	mA
Negative Analog Power-Supply Current	I_{AVSS}	No load, external reference, output at zero scale	-1.5	-0.8		mA
Interface Power-Supply Current	I_{VDDIO}	Digital inputs at V_{DDIO} or DGND		0.2	5.0	μA
Positive Analog Power-Supply Power-Down Current		$PD = V_{DDIO}$, power-down mode		20	50	μA
Negative Analog Power-Supply Power-Down Current		$PD = V_{DDIO}$, power-down mode	-5	-2		μA
DYNAMIC PERFORMANCE						
Voltage Output Slew Rate	SR	From 10% to 90% full scale, positive and negative transitions		4.9		V/ μs
Voltage Output Settling Time	t_S	From falling edge of LDAC to within 0.003% FS, $R_L = 10k\Omega$, $DIN = 04000h$ (6.25% FS) to $3C000h$ (93.75% FS)		3		μs

MAX5318

18-Bit, High-Accuracy Voltage Output DAC with Digital Gain, Offset Control, and SPI Interface

ELECTRICAL CHARACTERISTICS (continued)

($V_{AVDD} = V_{DDIO} = 2.7V$ to $3.3V$, $V_{AVSS} = -1.25V$, $V_{AGND} = V_{DGND} = V_{AGND_F} = V_{AGND_S} = 0V$, $V_{REF} = 2.5V$, $TC/\overline{SB} = PD = \overline{LDAC} = \overline{M/\overline{Z}} = DGND$, $\overline{RST} = V_{DDIO}$, $C_{REF0} = 100pF$, $C_L = 100pF$, $R_L = 10k\Omega$, $C_{BYPASS} = 1\mu F$, $GAIN = 0x3FFFF$, $OFFSET = 0x00000$, $T_A = -40^\circ C$ to $+105^\circ C$, unless otherwise noted. Typical values are at $T_A = +25^\circ C$.) ($GAIN = 0x3FFFF$ and $OFFSET = 0x00000$.) (Note 2)

PARAMETER	SYMBOL	CONDITIONS	MIN	TYP	MAX	UNITS
Busy Time	t_{BUSY}	(Note 5)		1.9		μs
DAC Glitch Impulse		Major code transition (1FFFFh to 20000h), $R_L = 10k\Omega$, $C_L = 50pF$		2.5		nVs
Digital Feedthrough		$CSB = V_{DDIO}$, $f_{SCLK} = 1kHz$, all digital inputs from 0V to V_{DDIO}		1		nVs
Output Voltage-Noise Spectral Density		At $f = 1kHz$ to $10kHz$, without reference, code = 20000h		26		nV/\sqrt{Hz}
Output Voltage Noise		At $f = 0.1Hz$ to $10Hz$, without reference, code = 20000h		1.55		μV_{P-P}
Wake-Up Time		From power-down mode		75		μs
Power-Up Time		From power-off		2		ms

DIGITAL INTERFACE ELECTRICAL CHARACTERISTICS

($V_{AVDD} = 5V$, $V_{DDIO} = 2.7V$ to $5.5V$, $V_{AVSS} = -1.25V$, $V_{REF} = 4.096V$, $R_L = 10k\Omega$, $TC/\overline{SB} = \overline{M/\overline{Z}} = DGND$, $C_{REF0} = 100pF$, $C_{BYPASS} = 1\mu F$, $T_A = -40^\circ C$ to $+105^\circ C$, unless otherwise noted. Typical values are at $T_A = +25^\circ C$.) ($GAIN = 0x3FFFF$ and $OFFSET = 0x00000$.) (Note 2)

PARAMETER	SYMBOL	CONDITIONS	MIN	TYP	MAX	UNITS
DIGITAL INPUTS (SCLK, DIN, CS, LDAC, M/Z, RST)						
Input High Voltage	V_{IH}		$0.7 \times V_{DDIO}$			V
Input Low Voltage	V_{IL}				$0.3 \times V_{DDIO}$	V
Input Hysteresis (Note 4)	V_{IHYST}		200	300		mV
Input Leakage Current	I_{IN}			± 0.1	± 1	μA
Input Capacitance	C_{IN}			10		pF
DIGITAL OUTPUT CHARACTERISTICS (DOUT, READY, BUSY)						
Output Low Voltage	V_{OL}	$I_{SOURCE} = 5.0mA$			0.25	V
Output High Voltage	V_{OH}	$I_{SINK} = 5.0mA$, except for \overline{BUSY}	$V_{DDIO} - 0.25$			V
Output Three-State Leakage	I_{OZ}	DOUT only		± 0.1	± 1	μA
Output Three-State Capacitance	C_{OZ}	DOUT only		15		pF
Output Short-Circuit Current	I_{OSS}	$V_{DDIO} = 5.25V$		± 150		mA

MAX5318

18-Bit, High-Accuracy Voltage Output DAC with Digital Gain, Offset Control, and SPI Interface

DIGITAL INTERFACE ELECTRICAL CHARACTERISTICS (continued)

($V_{AVDD} = 5V$, $V_{DDIO} = 2.7V$ to $5.5V$, $V_{AVSS} = -1.25V$, $V_{REF} = 4.096V$, $R_L = 10k\Omega$, $TC/\overline{SB} = M/\overline{Z} = DGND$, $C_{REF0} = 100pF$, $C_{BYPASS} = 1\mu F$, $T_A = -40^\circ C$ to $+105^\circ C$, unless otherwise noted. Typical values are at $T_A = +25^\circ C$.) (GAIN = 0x3FFFF and OFFSET = 0x00000.) (Note 2)

PARAMETER	SYMBOL	CONDITIONS		MIN	TYP	MAX	UNITS
TIMING CHARACTERISTICS							
Serial Clock Frequency	f_{SCLK}	Stand-alone, write mode				50	MHz
		Stand-alone, read mode and daisy-chained read and write modes (Note 5)				12.5	
SCLK Period	t_{CP}	Stand-alone, write mode		20			ns
		Stand-alone, read mode and daisy-chained read and write modes		80			
SCLK Pulse Width High	t_{CH}	40% duty cycle		8			ns
SCLK Pulse Width Low	t_{CL}	40% duty cycle		8			ns
\overline{CS} Fall to SCLK Fall Setup Time	t_{CSSO}	First SCLK falling edge	Stand-alone, write mode	8			ns
			Stand-alone, read mode and daisy-chained read and write modes	38			
\overline{CS} Fall to SCLK Fall Hold Time	t_{CSH0}	Inactive falling edge preceding first falling edge		0			ns
SCLK Fall to \overline{CS} Rise Hold Time	t_{CSH1}	24th falling edge		2			ns
DIN to SCLK Fall Setup Time	t_{DS}			5			ns
DIN to SCLK Fall Hold Time	t_{DH}			4.5			ns
SCLK Rise to DOUT Settle Time	t_{DOT}	$C_L = 20pF$ (Note 6)				32	ns
SCLK Rise to DOUT Hold Time	t_{DOH}	$C_L = 0pF$ (Note 6)		2			ns
SCLK Fall to DOUT Disable Time	t_{DOZ}	24th active edge deassertion		2		30	ns
\overline{CS} Fall to DOUT Enable	t_{DOE}	Asynchronous assertion		2		30	ns
\overline{CS} Rise to DOUT Disable	t_{CSDOZ}	Stand-alone, aborted sequence				35	ns
		Daisy-chained, aborted sequence				70	
SCLK Fall to \overline{READY} Fall	t_{CRF}	24th falling-edge assertion, $C_L = 20pF$				30	ns
SCLK Fall to \overline{READY} Hold	t_{CRH}	24th falling-edge assertion, $C_L = 0pF$		2			ns
SCLK Fall to \overline{BUSY} Fall	t_{CBF}	\overline{BUSY} assertion			5		ns
\overline{CS} Rise to \overline{READY} Rise	t_{CSR}	$C_L = 20pF$				35	ns
\overline{CS} Rise to SCLK Fall	t_{CSA}	24th falling edge, aborted sequence		20			ns
\overline{CS} Pulse Width High	t_{CSPW}	Stand alone		20			ns
SCLK Fall to \overline{CS} Fall	t_{CSF}	24th falling edge		100			ns
\overline{LDAC} Pulse Width	t_{LDPW}			20			ns
\overline{LDAC} Fall to SCLK Fall Hold	t_{LDH}	Last active falling edge		20			ns
\overline{RST} Pulse Width	t_{RSTPW}			20			ns

MAX5318

18-Bit, High-Accuracy Voltage Output DAC with Digital Gain, Offset Control, and SPI Interface

DIGITAL INTERFACE ELECTRICAL CHARACTERISTICS

($V_{AVDD} = 5V$, $V_{DDIO} = 1.8V$ to $2.7V$, $V_{AVSS} = -1.25V$, $V_{REF} = 4.096V$, $R_L = 10k\Omega$, $TC/\overline{SB} = M/\overline{Z} = DGND$, $C_{REF0} = 100pF$, $C_{BYPASS} = 1\mu F$, $T_A = -40^\circ C$ to $+105^\circ C$, unless otherwise noted. Typical values are at $T_A = +25^\circ C$.) (GAIN = 0x3FFFF and OFFSET = 0x00000.) (Note 2)

PARAMETER	SYMBOL	CONDITIONS	MIN	TYP	MAX	UNITS
DIGITAL INPUTS (SCLK, DIN, \overline{CS}, LDAC, M/Z, RST)						
Input High Voltage	V_{IH}		0.8 x V_{DDIO}			V
Input Low Voltage	V_{IL}				0.2 x V_{DDIO}	V
Input Hysteresis (Note 4)	V_{IHYST}		200	300		mV
Input Leakage Current	I_{IN}	Input = 0V at V_{DDIO}		± 0.1	± 1	μA
Input Capacitance	C_{IN}			10		pF
DIGITAL OUTPUTS CHARACTERISTICS (DOUT, \overline{READY}, \overline{BUSY})						
Output Low Voltage	V_{OL}	$I_{SOURCE} = 1.0mA$			0.2	V
Output High Voltage	V_{OH}	$I_{SINK} = 1.0mA$, except for \overline{BUSY}	$V_{DDIO} - 0.2$			V
Output Three-State Leakage	I_{OZ}	DOUT only		± 0.1	± 1	μA
Output Three-State Capacitance	C_{OZ}	DOUT only		15		pF
Output Short-Circuit Current	I_{OSS}	$V_{DDIO} = 2.7V$		± 150		mA
TIMING CHARACTERISTICS						
Serial Clock Frequency	f_{SCLK}	Stand-alone write mode			50	MHz
		Stand-alone read mode and daisy-chained read and write modes (Note 6)			8	
SCLK Period	t_{CP}	Stand-alone write mode	20			ns
		Stand-alone read mode and daisy-chained read and write modes	125			
SCLK Pulse-Width High	t_{CH}	40% duty cycle	9			ns
SCLK Pulse-Width Low	t_{CL}	40% duty cycle	9			ns
\overline{CS} Fall to SCLK Fall Setup Time	t_{CSSO}	First SCLK falling edge	Stand-alone write mode	12		ns
			Stand-alone read mode and daisy-chained read and write modes	72		
\overline{CS} Fall to SCLK Fall Hold Time	t_{CSH0}	Inactive falling edge preceding first falling edge	0			ns
SCLK Fall to \overline{CS} Rise Hold Time	t_{CSH1}	24th falling edge	4			ns
DIN to SCLK Fall Setup Time	t_{DS}		8			ns
DIN to SCLK Fall Hold Time	t_{DH}		8			ns
SCLK Rise to DOUT Settle Time	t_{DOT}	$C_L = 20pF$ (Note 7)			40	ns
SCLK Rise to DOUT Hold Time	t_{DOH}	$C_L = 0pF$ (Note 7)	2			ns

MAX5318

18-Bit, High-Accuracy Voltage Output DAC with Digital Gain, Offset Control, and SPI Interface

DIGITAL INTERFACE ELECTRICAL CHARACTERISTICS (continued)

($V_{AVDD} = 5V$, $V_{DDIO} = 1.8V$ to $2.7V$, $V_{AVSS} = -1.25V$, $V_{REF} = 4.096V$, $R_L = 10k\Omega$, $TC/\overline{SB} = M/\overline{Z} = DGND$, $C_{REF0} = 100pF$, $C_{BYPASS} = 1\mu F$, $T_A = -40^\circ C$ to $+105^\circ C$, unless otherwise noted. Typical values are at $T_A = +25^\circ C$.) (GAIN = 0x3FFFF and OFFSET = 0x00000.) (Note 2)

PARAMETER	SYMBOL	CONDITIONS	MIN	TYP	MAX	UNITS
SCLK Fall to DOUT Disable Time	t_{DOZ}	24th active edge deassertion	2		40	ns
\overline{CS} Fall to DOUT Enable	t_{DOE}	Asynchronous assertion	2		50	ns
\overline{CS} Rise to DOUT Disable	t_{CSDOZ}	Stand-alone, aborted sequence			70	ns
		Daisy-chained, aborted sequence			130	
SCLK Fall to \overline{READY} Fall	t_{CRF}	24th falling edge assertion, $C_L = 20pF$			60	ns
SCLK Fall to \overline{READY} Hold	t_{CRH}	24th falling edge assertion, $C_L = 0pF$	2			ns
SCLK Fall to \overline{BUSY} Fall	t_{CBF}	\overline{BUSY} assertion		5		ns
\overline{CS} Rise to \overline{READY} Rise	t_{CSR}	$C_L = 20pF$			60	ns
\overline{CS} Rise to SCLK Fall	t_{CSA}	24th falling edge, aborted sequence	20			ns
\overline{CS} Pulse Width High	t_{CSPW}	Stand alone	20			ns
SCLK Fall to \overline{CS} Fall	t_{CSF}	24th falling edge	100			ns
\overline{LDAC} Pulse Width	t_{LDPW}		20			ns
\overline{LDAC} Fall to SCLK Fall Hold	t_{LDH}	Last active falling edge	20			ns
\overline{RST} Pulse Width	t_{RSTPW}		20			ns

Note 2: All devices are 100% tested at $T_A = +25^\circ C$ and $T_A = +105^\circ C$. Limits at $T_A = -40^\circ C$ are guaranteed by design.

Note 3: Linearity is tested from V_{REF} to AGND.

Note 4: Guaranteed by design.

Note 5: The total analog throughput time from DIN to V_{OUT} is the sum of t_S and t_{BUSY} (4.9 μs , typ).

Note 6: Daisy-chain speed is relaxed to accommodate ($t_{CRF} + t_{CSS0}$).

Note 7: DOUT speed limits overall SPI speed..

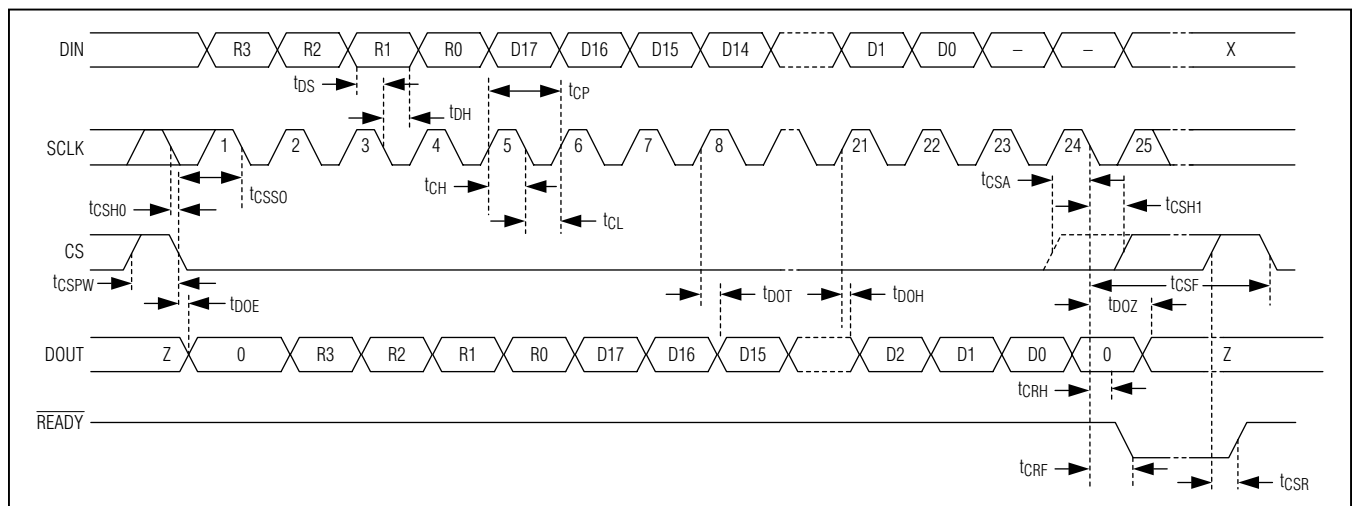

Figure 1. Serial Interface Timing Diagram, Stand-Alone Operation

MAX5318

18-Bit, High-Accuracy Voltage Output DAC with Digital Gain, Offset Control, and SPI Interface

Typical Operating Characteristics

($V_{AVDD} = V_{DDIO} = 5V$, $V_{AVSS} = -1.25V$, $V_{AGND} = V_{DGND} = V_{AGND_F} = V_{AGND_S} = 0V$; $V_{REF} = 4.096V$, $TC/\overline{SB} = PD = M/\overline{Z} = DGND$, $\overline{RST} = V_{DDIO}$, $C_{REF0} = 100pF$, $C_L = 100pF$, $R_L = 10k\Omega$, $C_{BYPASS} = 1\mu F$, $T_A = +25^\circ C$, unless otherwise noted.)

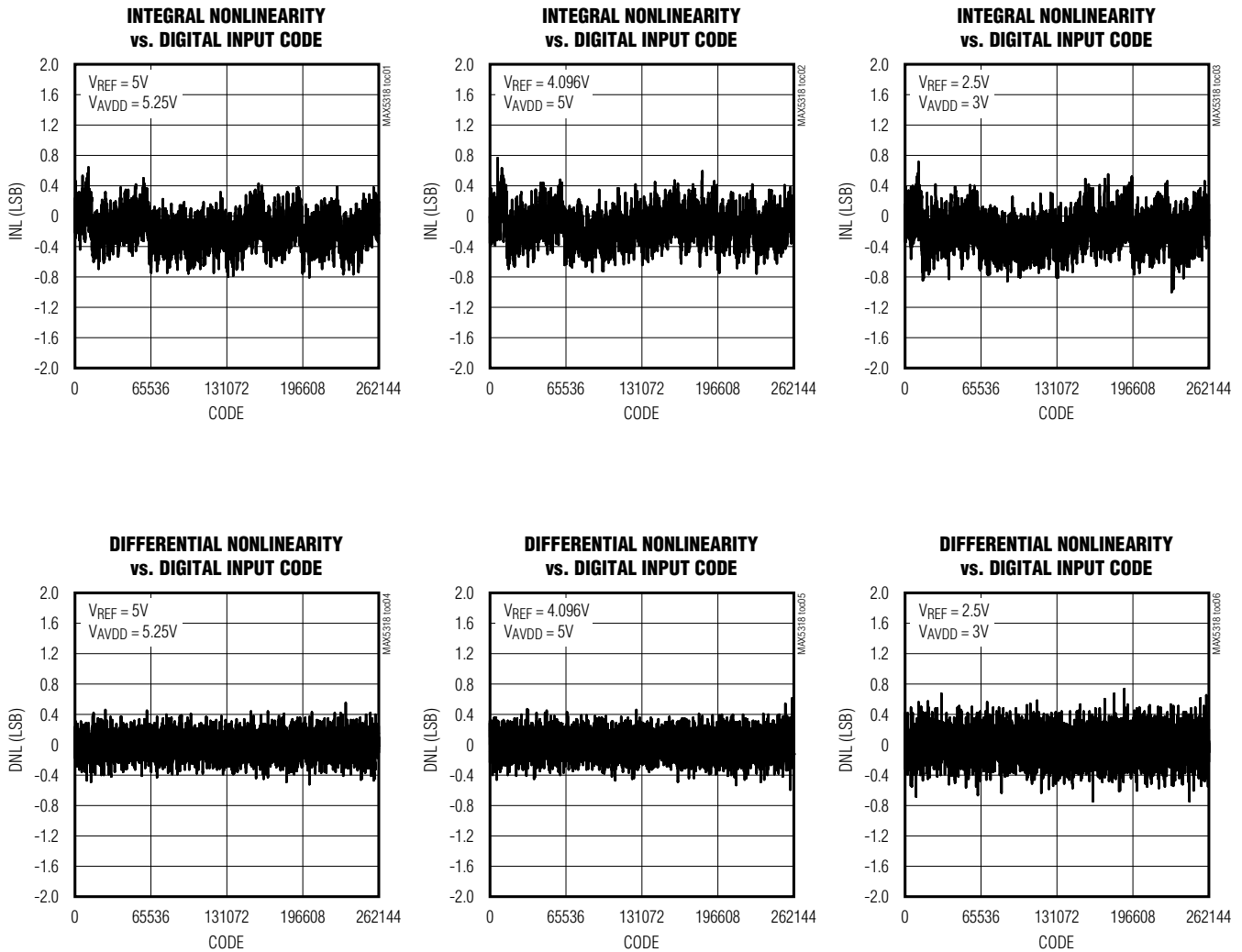

MAX5318

18-Bit, High-Accuracy Voltage Output DAC with Digital Gain, Offset Control, and SPI Interface

Typical Operating Characteristics (continued)

($V_{AVDD} = V_{DDIO} = 5V$, $V_{AVSS} = -1.25V$, $V_{AGND} = V_{DGND} = V_{AGND_F} = V_{AGND_S} = 0V$; $V_{REF} = 4.096V$, $TC/\overline{SB} = PD = M/\overline{Z} = DGND$, $\overline{RST} = V_{DDIO}$, $C_{REF0} = 100pF$, $C_L = 100pF$, $R_L = 10k\Omega$, $C_{BYPASS} = 1\mu F$, $T_A = +25^\circ C$, unless otherwise noted.)

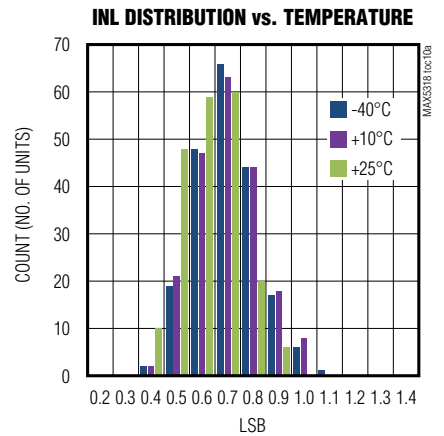
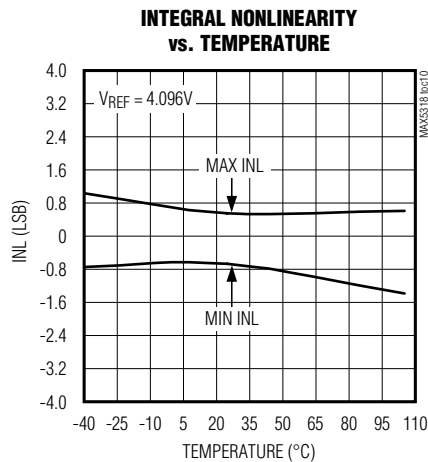
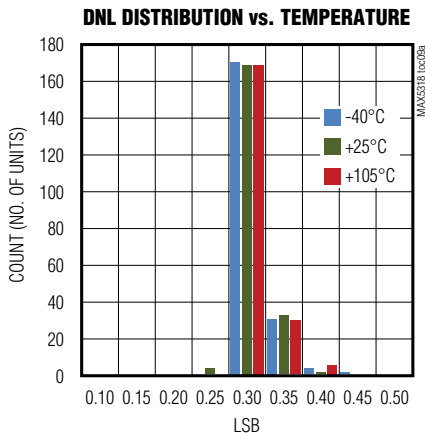
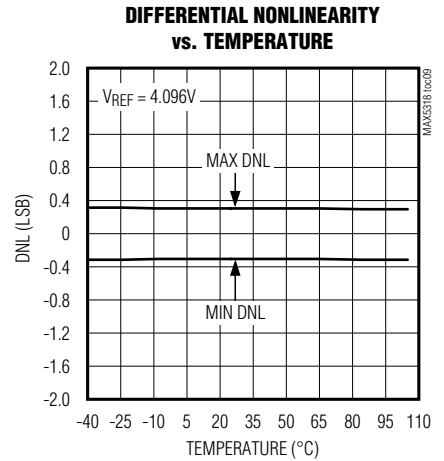
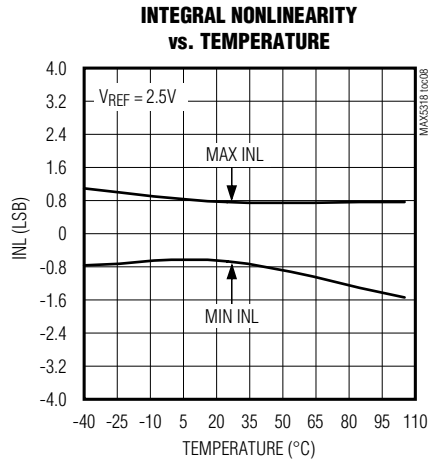
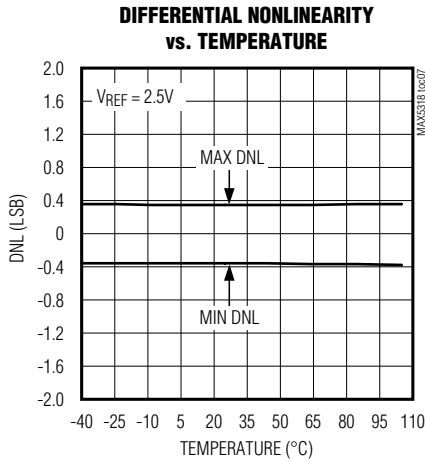

MAX5318

18-Bit, High-Accuracy Voltage Output DAC with Digital Gain, Offset Control, and SPI Interface

Typical Operating Characteristics (continued)

($V_{AVDD} = V_{DDIO} = 5V$, $V_{AVSS} = -1.25V$, $V_{AGND} = V_{DGND} = V_{AGND_F} = V_{AGND_S} = 0V$; $V_{REF} = 4.096V$, $TC/SB = PD = M/\bar{Z} = DGND$, $RST = V_{DDIO}$, $C_{REF0} = 100pF$, $C_L = 100pF$, $R_L = 10k\Omega$, $C_{BYPASS} = 1\mu F$, $T_A = +25^\circ C$, unless otherwise noted.)

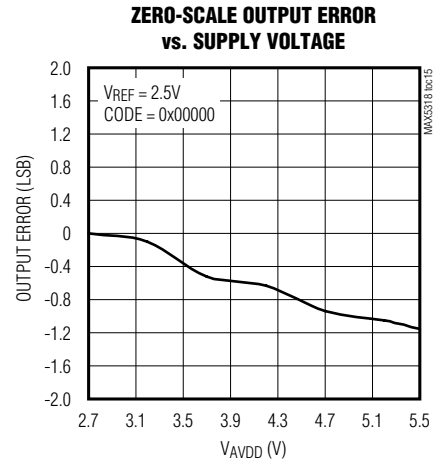
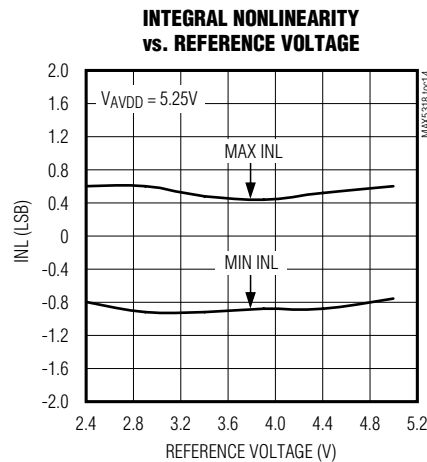
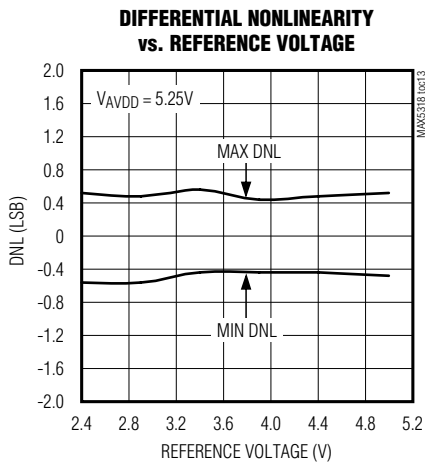
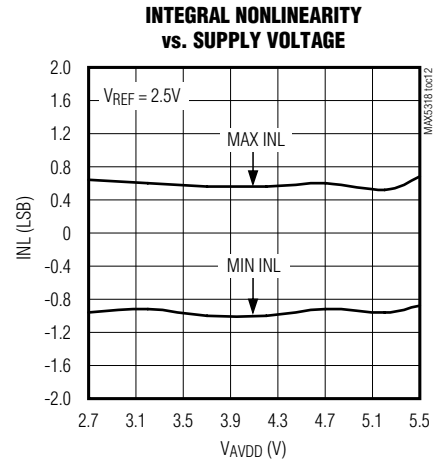
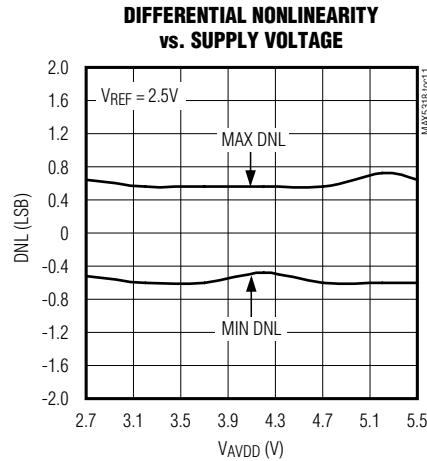
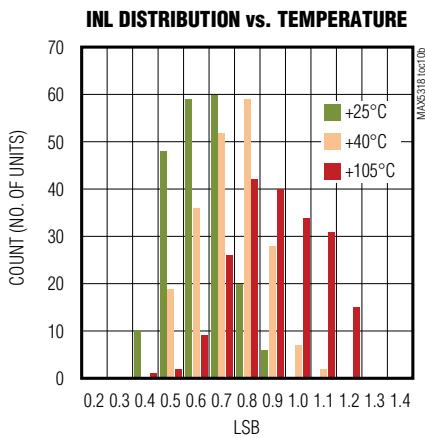

MAX5318

18-Bit, High-Accuracy Voltage Output DAC with Digital Gain, Offset Control, and SPI Interface

Typical Operating Characteristics (continued)

($V_{AVDD} = V_{DDIO} = 5V$, $V_{AVSS} = -1.25V$, $V_{AGND} = V_{DGND} = V_{AGND_F} = V_{AGND_S} = 0V$; $V_{REF} = 4.096V$, $TC/SB = PD = M/\bar{Z} = DGND$, $RST = V_{DDIO}$, $C_{REF0} = 100pF$, $C_L = 100pF$, $R_L = 10k\Omega$, $C_{BYPASS} = 1\mu F$, $T_A = +25^\circ C$, unless otherwise noted.)

FULL-SCALE OUTPUT ERROR vs. SUPPLY VOLTAGE

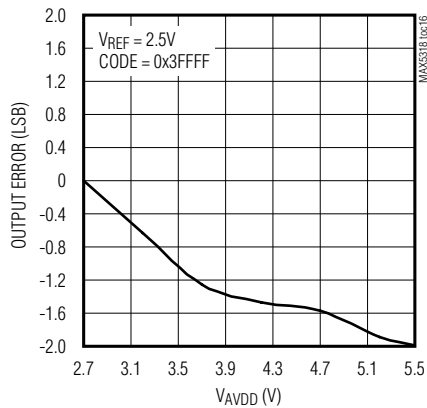

ZERO-SCALE OUTPUT ERROR vs. OUTPUT CURRENT

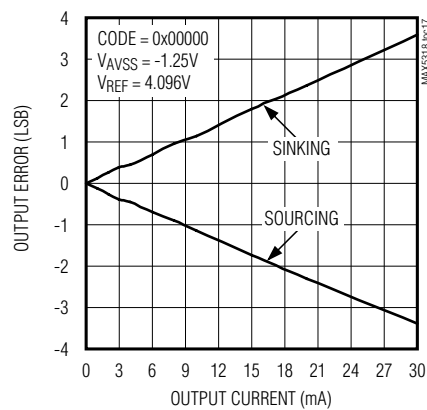

ZERO CODE ERROR DISTRIBUTION vs. TEMPERATURE

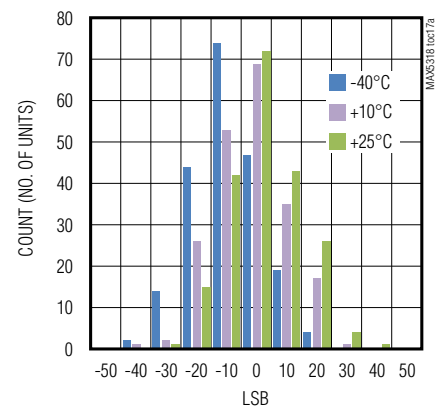

ZERO CODE ERROR DISTRIBUTION vs. TEMPERATURE

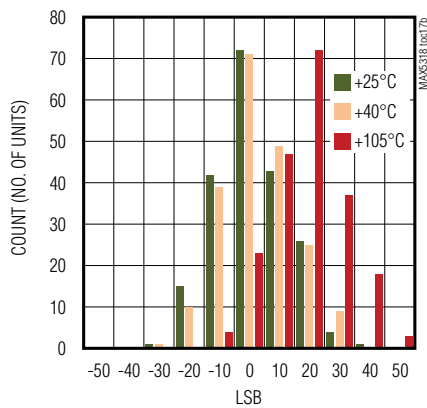

ZERO CODE ERROR DRIFT

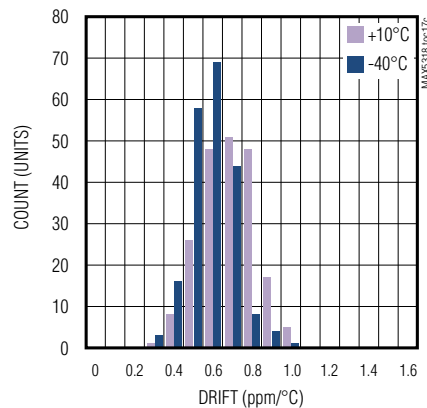

ZERO CODE ERROR DRIFT

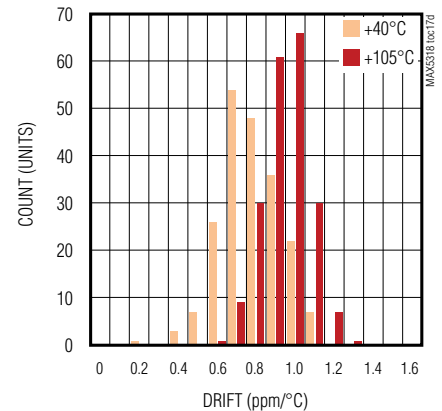

MAX5318

18-Bit, High-Accuracy Voltage Output DAC with Digital Gain, Offset Control, and SPI Interface

Typical Operating Characteristics (continued)

($V_{AVDD} = V_{DDIO} = 5V$, $V_{AVSS} = -1.25V$, $V_{AGND} = V_{DGND} = V_{AGND_F} = V_{AGND_S} = 0V$; $V_{REF} = 4.096V$, $TC/SB = PD = M/\bar{Z} = DGND$, $\overline{RST} = V_{DDIO}$, $C_{REF0} = 100pF$, $C_L = 100pF$, $R_L = 10k\Omega$, $C_{BYPASS} = 1\mu F$, $T_A = +25^\circ C$, unless otherwise noted.)

FULL-SCALE OUTPUT ERROR vs. OUTPUT CURRENT

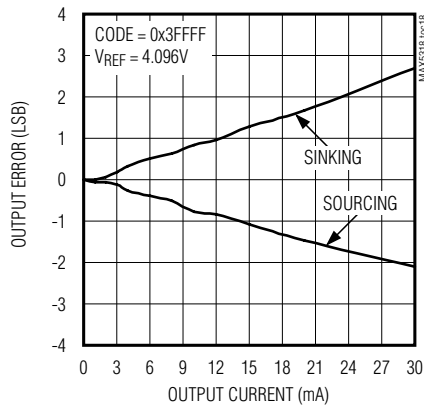

GAIN ERROR TEMPERATURE COEFFICIENT

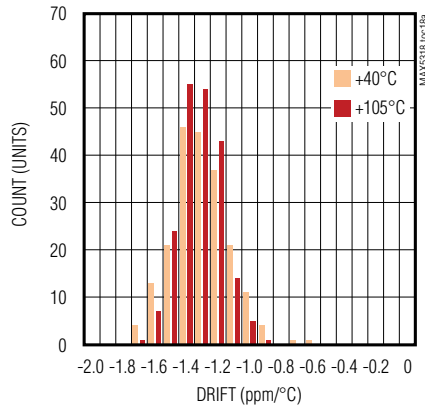

GAIN ERROR TEMPERATURE COEFFICIENT

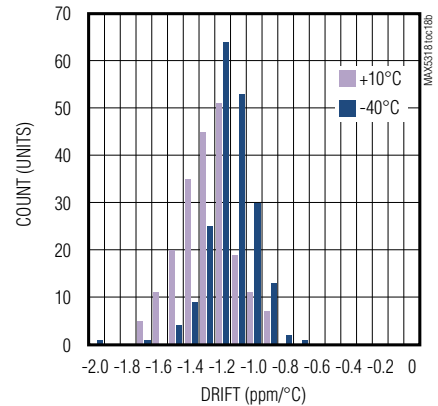

OUTPUT DRIVE CAPABILITY

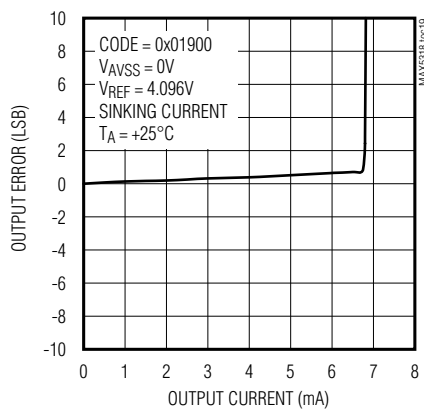

OUTPUT DRIVE CAPABILITY

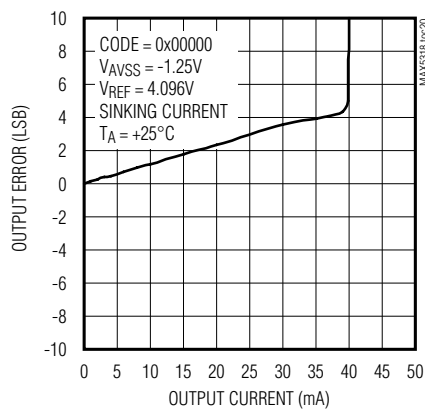

OUTPUT DRIVE CAPABILITY

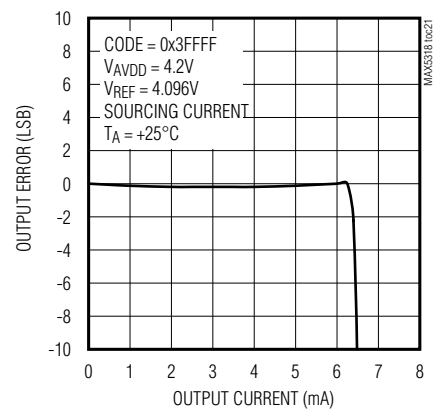

MAX5318

18-Bit, High-Accuracy Voltage Output DAC with Digital Gain, Offset Control, and SPI Interface

Typical Operating Characteristics (continued)

($V_{AVDD} = V_{DDIO} = 5V$, $V_{AVSS} = -1.25V$, $V_{AGND} = V_{DGND} = V_{AGND_F} = V_{AGND_S} = 0V$; $V_{REF} = 4.096V$, $TC/\overline{SB} = PD = M/\overline{Z} = DGND$, $\overline{RST} = V_{DDIO}$, $C_{REF0} = 100pF$, $C_L = 100pF$, $R_L = 10k\Omega$, $C_{BYPASS} = 1\mu F$, $T_A = +25^\circ C$, unless otherwise noted.)

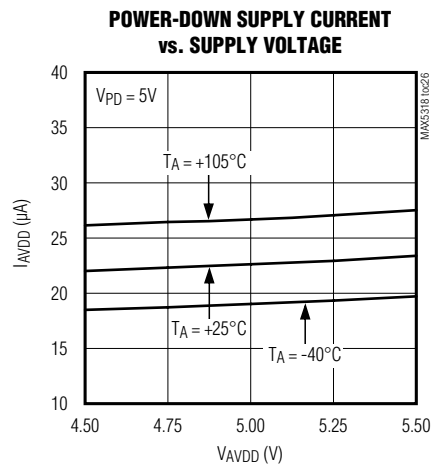
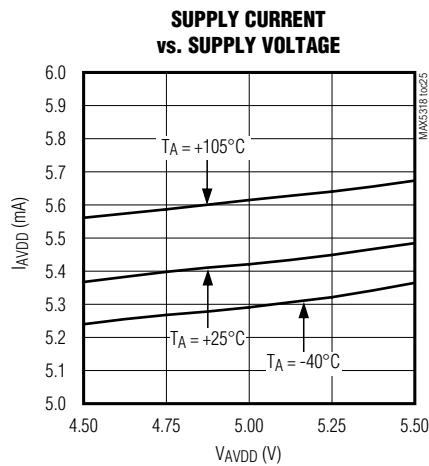
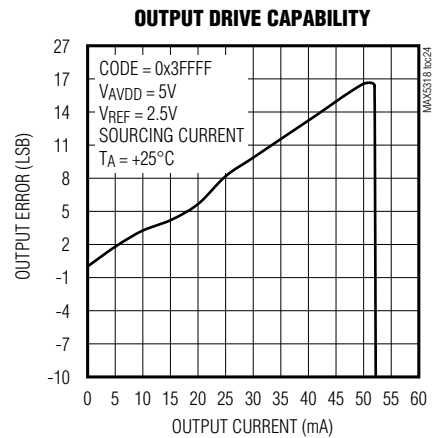
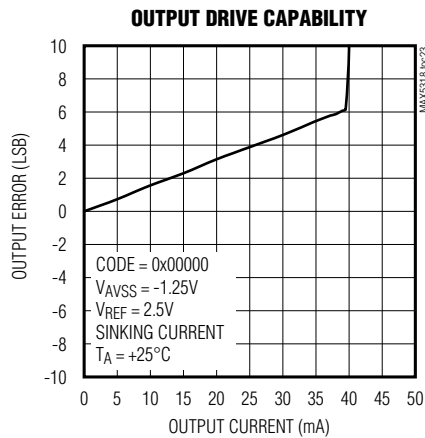
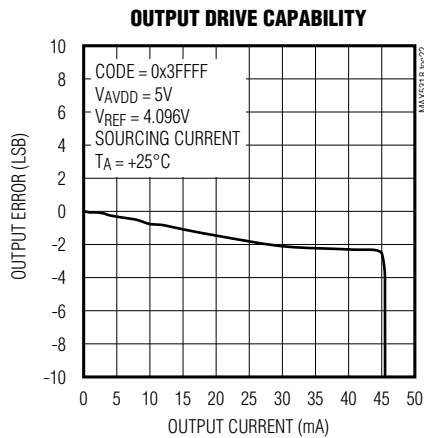

MAX5318

18-Bit, High-Accuracy Voltage Output DAC with Digital Gain, Offset Control, and SPI Interface

Typical Operating Characteristics (continued)

($V_{AVDD} = V_{DDIO} = 5V$, $V_{AVSS} = -1.25V$, $V_{AGND} = V_{DGND} = V_{AGND_F} = V_{AGND_S} = 0V$; $V_{REF} = 4.096V$, $TC/\overline{SB} = PD = M/\overline{Z} = DGND$, $\overline{RST} = V_{DDIO}$, $C_{REF0} = 100pF$, $C_L = 100pF$, $R_L = 10k\Omega$, $C_{BYPASS} = 1\mu F$, $T_A = +25^\circ C$, unless otherwise noted.)

0.1Hz TO 10Hz OUTPUT NOISE

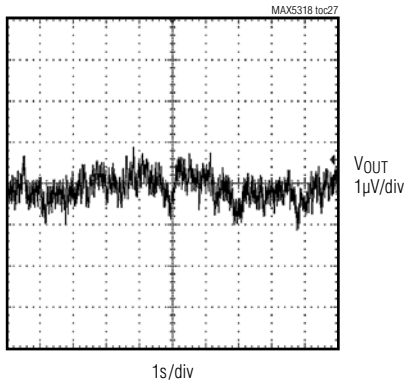

OUTPUT NOISE DENSITY

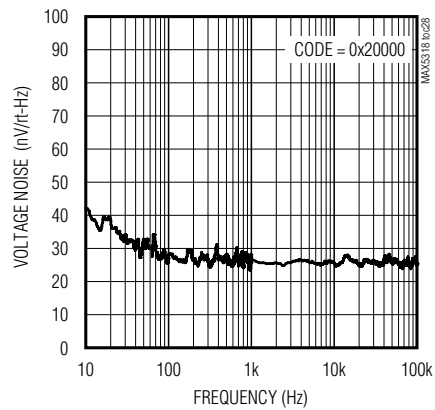

GROUND CURRENT vs. CODE

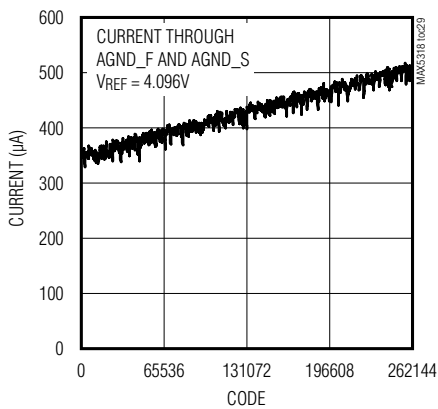

DIGITAL CLOCK FEEDTHROUGH

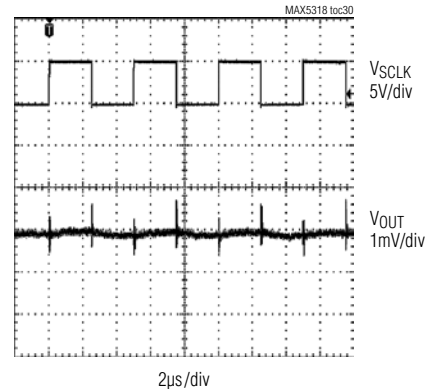

MAX5318

18-Bit, High-Accuracy Voltage Output DAC with Digital Gain, Offset Control, and SPI Interface

Typical Operating Characteristics (continued)

($V_{AVDD} = V_{DDIO} = 5V$, $V_{AVSS} = -1.25V$, $V_{AGND} = V_{DGND} = V_{AGND_F} = V_{AGND_S} = 0V$; $V_{REF} = 4.096V$, $TC/\overline{SB} = PD = M/\overline{Z} = DGND$, $\overline{RST} = V_{DDIO}$, $C_{REF0} = 100pF$, $C_L = 100pF$, $R_L = 10k\Omega$, $C_{BYPASS} = 1\mu F$, $T_A = +25^\circ C$, unless otherwise noted.)

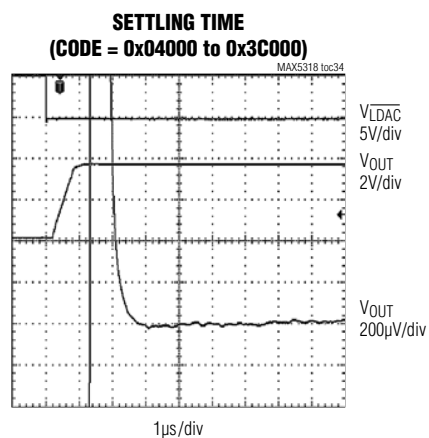
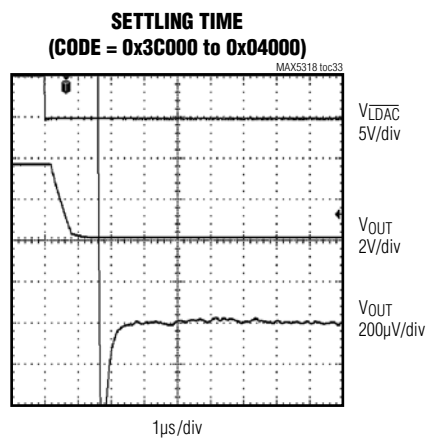
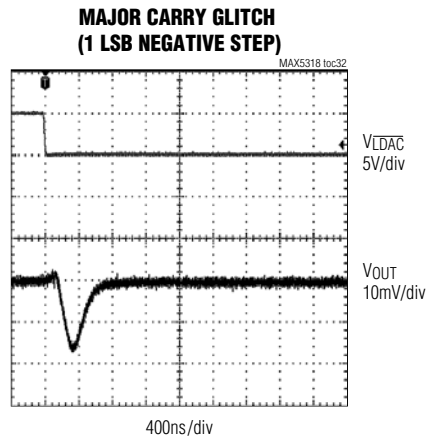
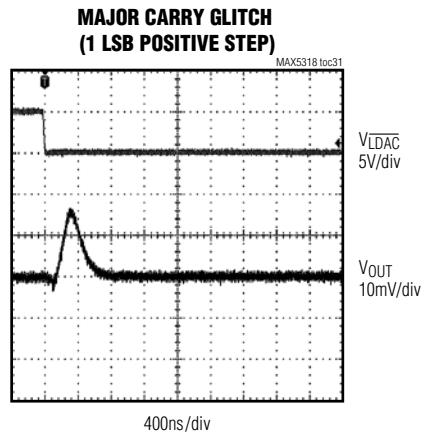

MAX5318

18-Bit, High-Accuracy Voltage Output DAC with Digital Gain, Offset Control, and SPI Interface

Typical Operating Characteristics (continued)

($V_{AVDD} = V_{DDIO} = 5V$, $V_{AVSS} = -1.25V$, $V_{AGND} = V_{DGND} = V_{AGND_F} = V_{AGND_S} = 0V$; $V_{REF} = 4.096V$, $TC/\overline{SB} = PD = M/\overline{Z} = DGND$, $\overline{RST} = V_{DDIO}$, $C_{REF0} = 100pF$, $C_L = 100pF$, $R_L = 10k\Omega$, $C_{BYPASS} = 1\mu F$, $T_A = +25^\circ C$, unless otherwise noted.)

ENTERING POWER-DOWN RESPONSE

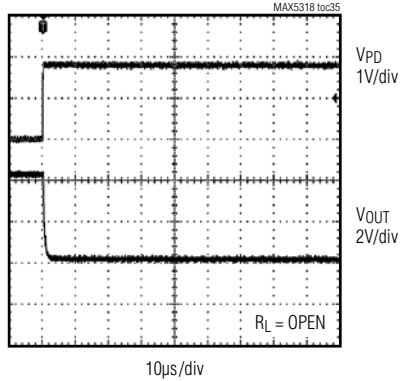

EXITING POWER-DOWN RESPONSE

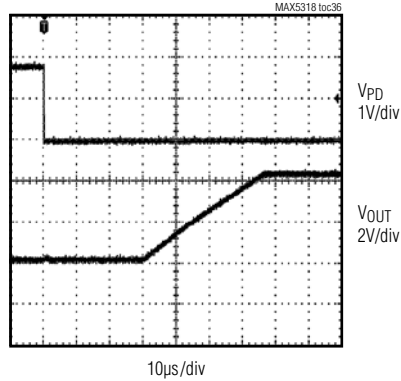

**SLOW POWER-UP RESPONSE
(RSTSEL = LOW)**

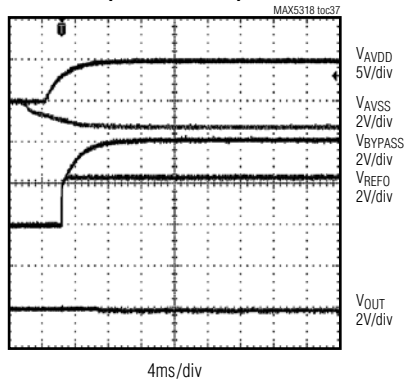

**SLOW POWER-UP RESPONSE
(RSTSEL = HIGH)**

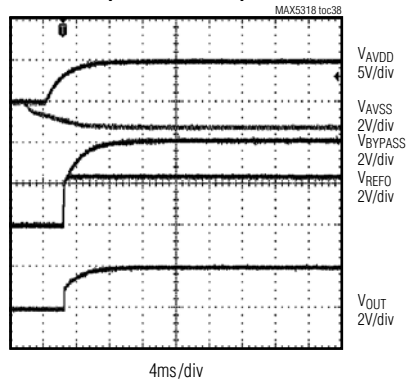

MAX5318

18-Bit, High-Accuracy Voltage Output DAC with Digital Gain, Offset Control, and SPI Interface

Pin Configuration

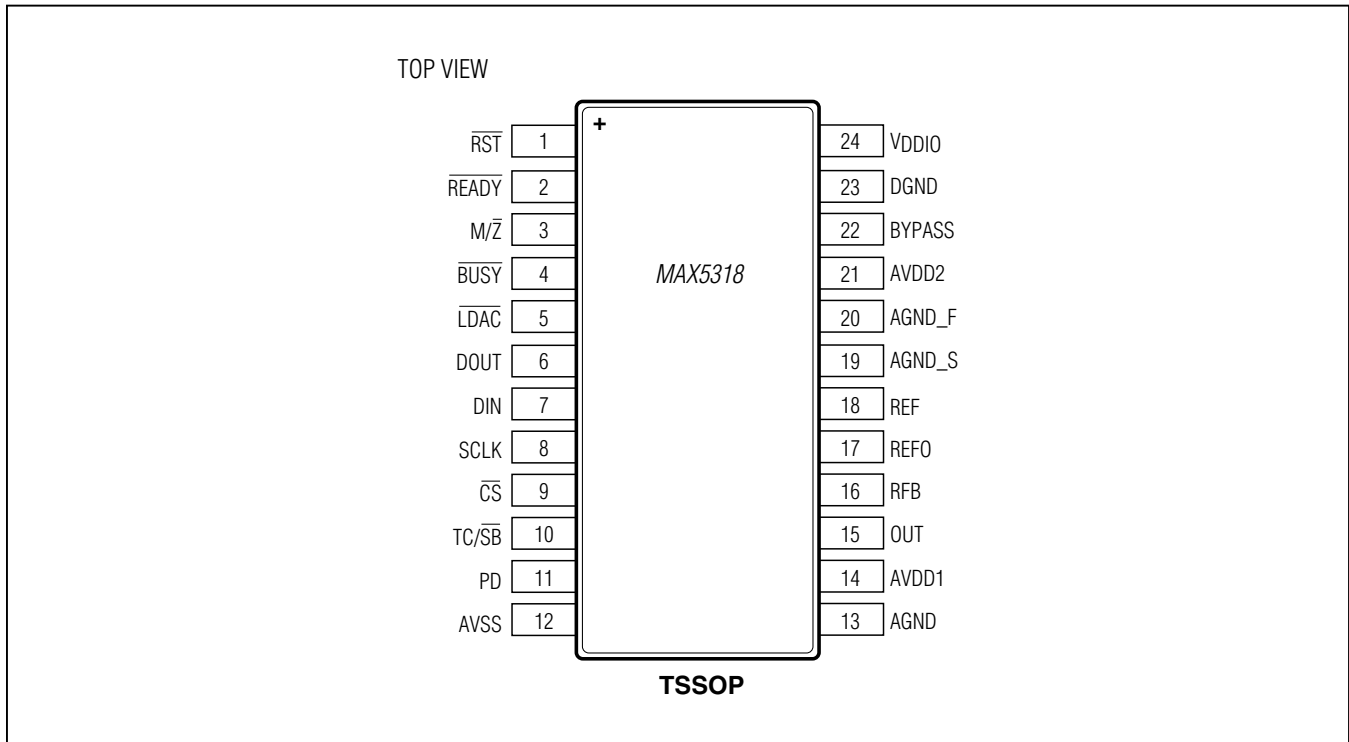

Pin Description

PIN	NAME	FUNCTION
1	$\overline{\text{RST}}$	Active-Low Reset Input. Drive $\overline{\text{RST}}$ low to DGND to put the device into a reset state. A reset state sets all SPI input registers to their default power-on reset states as defined by the state of inputs $\text{M}/\overline{\text{Z}}$ and $\text{TC}/\overline{\text{SB}}$. Set $\overline{\text{RST}}$ high to VDDIO, the DAC output remains at the state defined by $\text{M}/\overline{\text{Z}}$ until $\overline{\text{LDAC}}$ is taken low.
2	$\overline{\text{READY}}$	SPI Active-Low Ready Output. $\overline{\text{READY}}$ asserts low when the device successfully completes processing an SPI data frame. $\overline{\text{READY}}$ asserts high at the next rising edge of $\overline{\text{CS}}$. In daisy-chain applications, the $\overline{\text{READY}}$ output typically drives the $\overline{\text{CS}}$ input of the next device in the chain or a GPIO of a microcontroller.
3	$\text{M}/\overline{\text{Z}}$	Reset Select Input. $\text{M}/\overline{\text{Z}}$ selects the default state of the analog output (OUT) after power-on or a hardware or software reset. Connect $\text{M}/\overline{\text{Z}}$ to VDDIO to set the default output voltage to midscale or to DGND to set the default output voltage to zero scale.
4	$\overline{\text{BUSY}}$	Digital Input/Open-Drain Output. Connect a 2k Ω pullup resistor from $\overline{\text{BUSY}}$ to VDDIO. $\overline{\text{BUSY}}$ goes low during the internal calculations of the DAC register data. During this time, the user can continue writing new data to the DIN, OFFSET, and GAIN registers, but no further updates to the DAC register and DAC output can take place. If $\overline{\text{LDAC}}$ is asserted low while $\overline{\text{BUSY}}$ is low, this event is stored. $\overline{\text{BUSY}}$ is bidirectional, and can be asserted low externally to delay $\overline{\text{LDAC}}$ action. $\overline{\text{BUSY}}$ also goes low during power-on reset, when $\overline{\text{RST}}$ is low, or when software reset is activated.

MAX5318

18-Bit, High-Accuracy Voltage Output DAC with Digital Gain, Offset Control, and SPI Interface

Pin Description (continued)

PIN	NAME	FUNCTION
5	$\overline{\text{LDAC}}$	Active-Low Load DAC Logic Input. If $\overline{\text{LDAC}}$ is taken low while $\overline{\text{BUSY}}$ is inactive (high), the contents of the input registers are transferred to the DAC register and the DAC output is updated. If $\overline{\text{LDAC}}$ is taken low while $\overline{\text{BUSY}}$ is asserted low, the $\overline{\text{LDAC}}$ event is stored and the DAC register update is delayed until $\overline{\text{BUSY}}$ deasserts. Any event on $\overline{\text{LDAC}}$ during power-on reset or when $\overline{\text{RST}}$ is low is ignored.
6	DOUT	SPI Bus Serial Data Output. See the <i>Serial Interface</i> section for details.
7	DIN	SPI Bus Serial Data Input. See the <i>Serial Interface</i> section for details.
8	SCLK	SPI Bus Serial Clock Input. See the <i>Serial Interface</i> section for details.
9	$\overline{\text{CS}}$	SPI Bus Active-Low Chip-Select Input. See the <i>Serial Interface</i> section for details.
10	TC/ $\overline{\text{SB}}$	DIN Format Select Input. Connect TC/ $\overline{\text{SB}}$ to DGND to set the data input format to straight binary or to V_{DDIO} to set it to two's complement.
11	PD	Active-High Power-Down Input. Connect PD to DGND for normal operation. Connect PD to V_{DDIO} to place the device in power-down. In power-down, OUT (analog voltage output) is connected to AGND through a 2k Ω resistor, but the contents of the input registers and the DAC latch do not change. The SPI interface remains active in power-down.
12	AVSS	Negative Analog Power-Supply Input. Connect to AGND or a negative supply voltage. When connected to the negative supply voltage, bypass AVSS with a 0.1 μF capacitor to AGND.
13	AGND	Analog Ground. Connect to the analog ground plane.
14	AVDD1	Positive Analog Power-Supply Input. Bypass each AVDD_ locally with a 0.1 μF and 10 μF capacitor to AGND (analog ground plane). Connect AVDD1 and AVDD2 together.
15	OUT	Buffered Analog Voltage Output. Connect OUT to RFB externally to close the output buffer feedback loop. The buffered output is capable of directly driving a 10k Ω load. The state of $\overline{\text{M/Z}}$ sets the power-on reset state of OUT (zero or midscale). In power-down, OUT is connected to AGND through a 2k Ω pulldown resistor.
16	RFB	Feedback Resistor Input. RFB is connected through the internal feedback resistor to the inverting input of the analog output buffer. Externally connect RFB to OUT to close the output buffer feedback loop.
17	REFO	Voltage Reference Buffered Output. Bypass with a 100pF capacitor to AGND.
18	REF	High-Impedance 10M Ω Voltage Reference Input
19	AGND_S	DAC Analog Ground Sense
20	AGND_F	DAC Analog Ground Force. Connect to the analog ground plane.
21	AVDD2	Positive Analog Power-Supply Input. AVDD2 supplies power to the internal digital linear regulator. Bypass AVDD2 locally to AGND with 0.1 μF and 10 μF capacitors. Connect AVDD2 and AVDD1 together.
22	BYPASS	Internal Bypass Connection. Connect BYPASS to DGND with 0.01 μF and 1 μF capacitors.
23	DGND	Digital Ground
24	V_{DDIO}	Digital Interface Power-Supply Input. Connect to a 1.8V to 5.5V logic-level supply. Bypass V_{DDIO} with a 0.1 μF capacitor to DGND. The supply voltage at V_{DDIO} sets the logic-level for the digital interface.

MAX5318

18-Bit, High-Accuracy Voltage Output DAC with Digital Gain, Offset Control, and SPI Interface

Detailed Description

The MAX5318 is a high-accuracy, 18-bit, serial SPI input, buffered voltage output digital-to-analog converter (DAC) in a 4.4mm x 7.8mm, 24-lead TSSOP package. The device features ± 2 LSB INL (max) accuracy and a ± 1 LSB DNL (max) accuracy over the full temperature range of -40°C to $+105^{\circ}\text{C}$.

The DAC voltage output is buffered resulting in a fast settling time of $3\mu\text{s}$ and a low offset and gain drift of $\pm 0.5\text{ppm}/^{\circ}\text{C}$ of FSR (typ). The force-sense output (OUT) maintains accuracy while driving loads with long lead lengths. Additionally, a separate AVSS supply allows the output amplifier to go to 0V (GND) while maintaining full linearity performance.

The MAX5318 includes user-programmable digital gain and offset correction capability to enable easy system calibration.

At power-up, the device resets its outputs to zero or mid-scale, providing additional safety for applications, which drive valves or other transducers that need to be off on power-up. This is selected by the state of the M/\bar{Z} input on power-up.

The wide 2.7V to 5.5V supply voltage range and integrated low-drift, low-noise reference buffer amplifier makes for ease of use. Since the reference buffer input has a high input resistance, an external buffer is not required. The device accepts an external reference between 2.4V and $V_{\text{AVDD}} - 0.1\text{V}$ for maximum flexibility and rail-to-rail operation.

The MAX5318 features a 50MHz, 3-wire SPI, QSPI, MICROWIRE, and DSP-compatible serial interface. The separate digital interface supply voltage input (V_{DDIO}) is compatible with a wide range of digital logic levels from 1.8V to 5.5V, eliminating the need for separate voltage translators.

DAC Reference Buffer

The external reference input has a high input (REF) impedance of $10\text{M}\Omega \parallel 10\text{pF}$ and accepts an input voltage from $+2.4\text{V}$ to $V_{\text{AVDD}} - 0.1\text{V}$. Connect an external reference supply between REF and AGND. Bypass the reference buffer output REFO to AGND with a 100pF capacitor. Connect the anode of an external Schottky diode to REF and the cathode to AVDD1 to prevent internal ESD diode conduction in the event that the reference voltage comes

up before AVDD at power up. Follow the recommendations described in the [Power-Supply Sequencing](#) section.

Visit www.maximintegrated.com/products/references for a list of available external voltage-reference devices.

Output Amplifier (OUT)

The MAX5318 includes an internal buffer for the DAC output. The internal buffer provides improved load regulation for the DAC output. The output buffer slews at $5\text{V}/\mu\text{s}$ and drives up to $2\text{k}\Omega$ in parallel with 200pF . The buffer has a rail-to-rail output capable of swinging to within 100mV of AVDD_- and AVSS.

The positive analog supply voltage (AVDD_-) determines the maximum output voltage of the device as AVDD_- powers the output buffer.

The output is diode clamped to ground, preventing negative voltage excursions beyond approximately -0.6V .

Negative Supply Voltage (AVSS)

The negative supply voltage (AVSS) determines the minimum output voltage. If AVSS is connected to ground, the output voltage can be set to as low as 100mV without degrading linearity. For operation down to 0V, connect AVSS to a negative supply voltage between -0.1V and -1.5V . The MAX1735 is recommended for generating -1.25V from a -5V supply.

Force/Sense

The MAX5318 uses force/sense techniques to ensure that the load is regulated to the desired output voltage despite line drops due to long lead lengths. Since AGND_F and AGND_S have code dependent ground currents, a ground impedance less than $13\text{m}\Omega$ ensures that the INL will not degrade by more than 0.1 LSB. Form a star ground connection ([Figure 2a](#)) near the device with AGND_F, AGND_S, and AGND tied together. Always refer remote DAC loads to this system ground for best performance. [Figure 2b](#) shows how to configure the device and an external op amp for proper force/sense operation. The amplifier provides as much drive as needed to force the sensed voltage (measured between FFB and AGND_S) to equal the desired voltage.

MAX5318

18-Bit, High-Accuracy Voltage Output DAC with Digital Gain, Offset Control, and SPI Interface

18-Bit Ideal Transfer Function

The MAX5318 features 18-bit gain and 18-bit offset adjustment as shown in [Figure 3](#).

The incoming DIN code is multiplied and offset compensated by the generic equation shown in Equation 1. The resulting value is then applied to the DAC.

Equation 1) Generic gain and offset adjustment

$$DAC = DIN \times GAIN + OFFSET$$

The GAIN code is always an 18-bit straight binary word. The OFFSET code is always two's complement. It is therefore simply added to the output of the multiplier.

To guarantee that a gain of exactly 1 is possible, the actual gain coefficient applied to DIN is as defined in Equation 2.

Equation 2) Calculation of gain

$$G = \frac{(GAIN) + 1}{2^{18}}$$

When DIN is straight binary, the ideal transfer function is given by:

Equation 3) Straight binary ideal transfer function

$$V_{OUT} = G \times V_{DIN} + V_{OFFSET}$$

When DIN is two's complement, the ideal transfer function is given by:

Equation 4) Two's complement ideal transfer function

$$V_{OUT} = \frac{V_{REF}}{2} + G \times V_{DIN} + V_{OFFSET}$$

V_{DIN} and V_{OFFSET} are the voltages to which the DIN and OFFSET codes are converted and V_{OUT} is the voltage at the DAC output buffer. See the [Conversion Formulas for DIN, GAIN, and OFFSET](#) section for equations needed to convert the DIN and OFFSET codes into V_{DIN} and V_{OFFSET} .

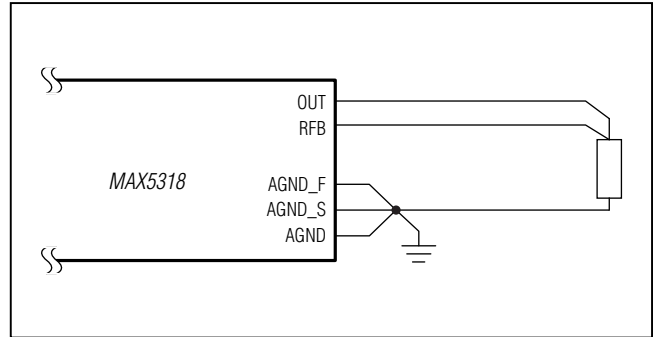

Figure 2a. Star Ground Connection

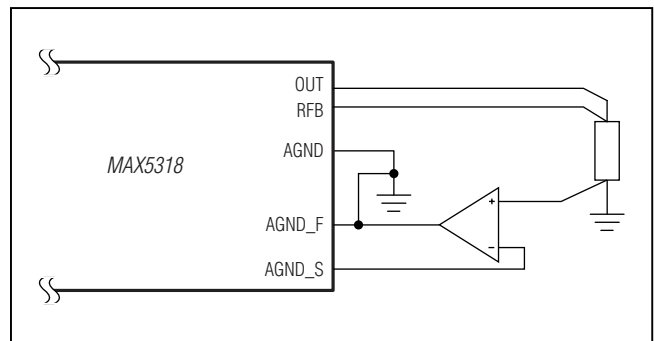

Figure 2b. Force/Sense Connection

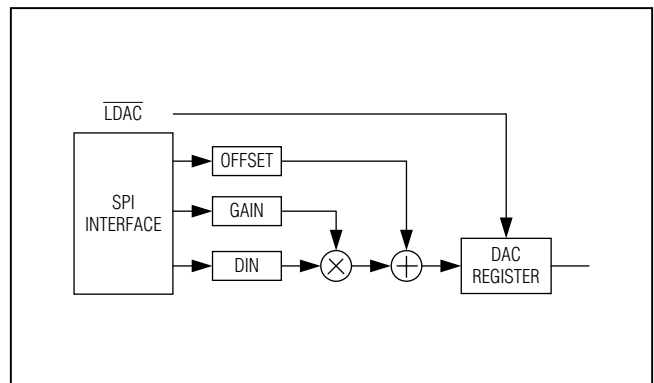

Figure 3. Gain and Offset Adjustment

MAX5318

18-Bit, High-Accuracy Voltage Output DAC with Digital Gain, Offset Control, and SPI Interface

The data DIN can be either straight binary or two's complement. In straight binary, zero code results in a zero-scale output. In two's complement, zero code results in a midscale output.

To better understand how GAIN and OFFSET affect the output voltage, see [Figure 4](#) and [Figure 5](#). Consider the generation of a ramp. For now assume OFFSET is set to 0x00000. In straight binary mode, with GAIN set to 0x3FFFF (G = 1), DIN starts at 0x00000 and increases to 0x3FFFF. The output voltage will start at 0V and increase to ($V_{REF} - 1$ LSB). If GAIN is reduced, the ramp will still start at 0V but the maximum level reached is reduced.

With DIN set to two's complement mode, to generate the same ramp, DIN would start at 0x20000 and increase until it wraps around to 0x00000. At this point the DAC output would be midscale. DIN then increases to 0x1FFFF where the output would be full-scale -1 LSB. As

GAIN is reduced, the start of the ramp becomes larger and the end of the ramp becomes smaller. The ramp is therefore centered at midscale.

In both cases, a nonzero value for OFFSET results in the output moving up or down.

Should the output of the gain and offset adjust block overflow full-scale or underflow zero-scale, the data is clipped so the DAC output will be clipped rather than overflow or underflow.

The effect of gain and offset adjustment is shown in [Figure 4](#) for straight binary mode and [Figure 5](#) for two's complement mode.

If any of the DIN, GAIN, or OFFSET registers is changed, the device takes $1.9\mu\text{s}$ (t_{BUSY}) to compute the new values to present to the DAC. While the device is computing the new DAC value, the \overline{BUSY} output is set low. See the section on the \overline{BUSY} output and \overline{LDAC} input for details.

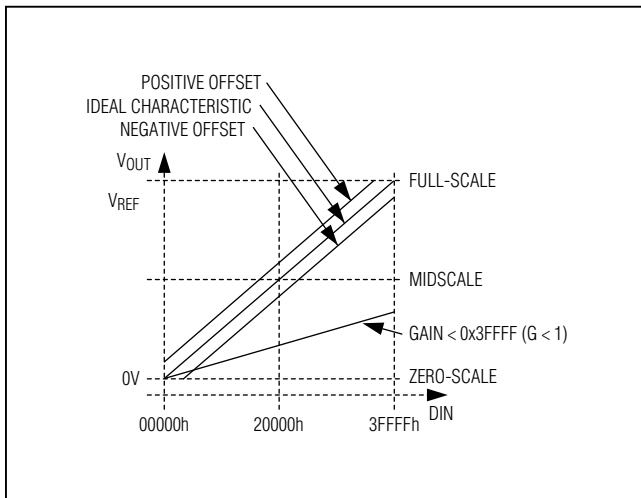

Figure 4. Gain and Offset Adjustment in Straight Binary Mode

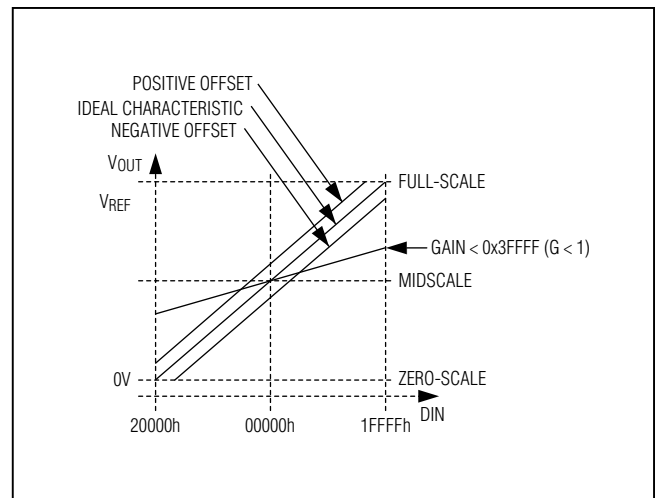

Figure 5. Gain and Offset Adjustment in Two's Complement Mode

MAX5318

18-Bit, High-Accuracy Voltage Output DAC with Digital Gain, Offset Control, and SPI Interface

Conversion Formulas for DIN, GAIN, and OFFSET

Tables 1a and 1b show how to convert the DIN code to V_{DIN} in straight binary and two's complement modes.

Table 2 shows how to convert the GAIN code to the gain factor G, which is multiplied with V_{DIN} . Table 3 shows how to convert the OFFSET code to V_{OFFSET} , which is summed with the product $G \cdot V_{DIN}$.

Input, Gain, and Offset Ranges

The ranges of DIN, GAIN, and OFFSET are summarized in [Table 4](#) to [Table 6](#). Also shown are the range values for the 18-bit MAX5318 with a 4.096V reference. Note that V_{REF} is the reference voltage applied to REF and 1 LSB is equal to $V_{REF}/2^{18}$.

Table 1a. Converting DIN to V_{DIN} (Straight Binary Mode)

DIN	EQUATION FOR V_{DIN}	RANGE
0x00000 to 0x3FFFF	$V_{DIN} = V_{REF} \times \frac{DIN}{2^{18}}$	0V to ($V_{REF} - 1$ LSB)

Table 1b. Converting DIN to V_{DIN} (Two's Complement Mode)

DIN	EQUATION FOR V_{DIN} AND V_{OFFSET}	RANGE
0x20000 to 0x3FFFF	$V_{DIN} = V_{REF} \times \left(\frac{DIN - 0x20000}{2^{18}} \right) - \frac{V_{REF}}{2}$	$V_{REF}/2$ to -1 LSB
0x00000 to 0x1FFFF	$V_{DIN} = V_{REF} \times \frac{CODE}{2^{18}}$	0V to ($V_{REF}/2 - 1$ LSB)

Table 2. Converting GAIN to G

GAIN	EQUATION	RANGE
0x00000 to 0x3FFFF	$G = \frac{GAIN + 1}{2^{18}}$	$1/2^{18}$ to 1

Table 3. Converting OFFSET to V_{OFFSET}

OFFSET	EQUATION	RANGE
0x20000 to 0x3FFFF	$V_{OFFSET} = V_{REF} \times \left(\frac{OFFSET - 0x20000}{2^{18}} \right) - \frac{V_{REF}}{2}$	$-V_{REF}/2$ to -1 LSB
0x00000 to 0x1FFFF	$V_{OFFSET} = V_{REF} \times \frac{OFFSET}{2^{18}}$	0V to ($V_{REF}/2 - 1$ LSB)

MAX5318

18-Bit, High-Accuracy Voltage Output DAC with Digital Gain, Offset Control, and SPI Interface

Table 4a. DIN Range (Straight Binary Mode)

RANGE	DIN	V _{DIN} (V)	VALUE (V)
Minimum	0x00000	0	0
Maximum	0x3FFFF	(V _{REF} - 1 LSB)	4.095984375

Table 4b. DIN Range (Two's Complement Mode)

RANGE	DIN	V _{DIN} (V)	VALUE (V)
Minimum	0x20000	0	0
Maximum	0x1FFFF	(V _{REF} - 1 LSB)	4.095984375

Table 5. GAIN Range

RANGE	GAIN	G	VALUE (V)
Minimum	0x00000	1/2 ¹⁸	0.0000038147
Maximum	0x3FFFF	1	1

Table 6. OFFSET Range

RANGE	OFFSET	V _{OFFSET} (V)	VALUE (V)
Minimum	0x20000	-V _{REF} /2	-2.048
Maximum	0x1FFFF	(V _{REF} /2 - 1 LSB)	2.047992188

Table 7. Straight Binary DIN Examples

DIN	V _{DIN} (V)	GAIN	G	OFFSET	V _{OFFSET} (V)	CALCULATION	COMMENT
0x20000	2.048	0x2FFFF	0.75	0x10000	1.024	$V_{OUT} = 0.75 \times 2.048 + 1.024 = 2.56V$	<ul style="list-style-type: none"> For V_{OUT}, use Equation 3 For V_{DIN}, use Table 1a For G, use Table 2 For V_{OFFSET}, use Table 3 second formula
0x30000	3.072	0x0FFFF	0.25	0x30000	-1.024	$V_{OUT} = 0.25 \times 3.072 - 1.024 = 0.512V$	<ul style="list-style-type: none"> For V_{OUT}, use Equation 3 For V_{DIN}, use Table 1a For G, use Table 2 For V_{OFFSET}, use Table 3 first formula

MAX5318

18-Bit, High-Accuracy Voltage Output DAC with Digital Gain, Offset Control, and SPI Interface

Table 8. Two's Complement DIN Examples

DIN	V _{DIN} (V)	GAIN	G	OFFSET	V _{OFFSET} (V)	CALCULATION	COMMENT
0x30000	-1.024	0x2FFFF	0.75	0x08000	0.512	$V_{OUT} = 4.096/2 + 0.75 \times (-1.024) + 0.512 = 1.792V$	<ul style="list-style-type: none"> For V_{OUT}, use Equation 4 For V_{DIN}, use Table 1b first formula For G, use Table 2 For V_{OFFSET}, use Table 3 second formula
0x10000	1.024	0x0FFFF	0.25	0x38000	-0.512	$V_{OUT} = 4.096/2 + 0.25 \times 1.024 - 0.512 = 1.792V$	<ul style="list-style-type: none"> For V_{OUT}, use Equation 4 For V_{DIN}, use Table 1b first formula For G, use Table 2 For V_{OFFSET}, use Table 3 first formula

Numerical Examples

Several numerical examples for the MAX5318, as shown in [Table 7](#) and [Table 8](#), illustrate how the gain and offset control changes the output voltage. The examples assume a reference voltage of 4.096V. Note that if the result of the calculation results in an under- or over-range output voltage, V_{OUT} is set to its zero or full-scale value, respectively. An under-range output is less than 0V and an over-range output is greater than V_{REF} - 1 LSB.

Reset

The device is reset upon power-on, hardware reset using \overline{RST} , or software reset using register 0x4, bit 15, command \overline{RSTSW} . After reset, the value of the input register, the DAC latch and the output voltage are set to the values defined by the M/ \overline{Z} input. If a hardware reset occurs during a SPI programming frame, anything before and after the reset for the frame will be ignored. A software reset initiated through the SPI interface takes effect after the end of the valid frame.

Output State Upon Reset

The output voltage can be set to either zero or mid-scale upon power-up, or a hardware or software reset, depending on the state of the M/ \overline{Z} input. After power-up, if the device detects that this input is low, the output voltage is set to zero scale. If M/ \overline{Z} is high, the output voltage is set to midscale.

Note that during reset, when \overline{RST} is low or \overline{RSTSW} is set to 0, the output voltage is set slightly lower than the value after coming out of reset. During reset, the output voltage is set to the values shown for the V_{OUT-RESET} specification in the *Electrical Characteristics*.

Power-Down

The device can be powered down by either hardware (pulling PD high) or software (setting the PD_SW bit in either the 0x4 or 0xC registers). Note that the hardware and software inputs are ORed. Asserting either is enough to place the device in power-down mode.

In order to restore normal operation to the device, satisfy both of these conditions:

- 1) Pull PD low.
- 2) Set the bits PD_SW's (in both 0x4 and 0xC registers) to 0.

In power-down, the output is internally connected to AGND through a 2k Ω resistor. The SPI interface remains active and the DAC register content remains unchanged.

Data Format Selection

(Straight Binary vs. Two's Complement)

The MAX5318 interprets the data code input (DIN) as either straight binary or two's complement. To choose the straight binary format, set the TC/SB input low. For two's complement, set the input high.

18-Bit, High-Accuracy Voltage Output DAC with Digital Gain, Offset Control, and SPI Interface

LDAC and BUSY Interaction

The BUSY line is open drain and is normally pulled up by an external resistor. It is software-configurable bidirectional and can be pulled down externally. If any of the DIN, GAIN, and OFFSET registers is changed, the device must calculate the value to be presented to the DAC register. To indicate to the host processor that the device is busy, the device pulls the BUSY output low. Once computation is complete, the device releases BUSY and the host processor can load the DAC by toggling the LDAC input. If LDAC is set low while BUSY is low, the LDAC event is latched and implemented when the computation is complete and BUSY rises.

There are four ways in which the LDAC and BUSY outputs can be used. This is shown graphically in [Figure 6](#).

- 1) The host sends a new command. The device sets BUSY low. The host monitors BUSY to determine when it goes high. The device then pulses LDAC low to update the DAC.
- 2) The host sends a new command. The device sets BUSY low. The host toggles LDAC low then high before BUSY goes high. The device latches the LDAC
- 3) LDAC is held low. The host sends a new command and the device sets BUSY low. The device updates the DAC when the processing is complete and BUSY goes high.
- 4) BUSY is pulled down externally to delay DAC update. The BUSY pin is bidirectional. To use BUSY as an input, set the NO_BUSY bit to 1 using the 0x4 or 0xC command. When configured as an input, pulling BUSY low at least 50ns before the device releases the line delays DAC update. DAC update occurs only after BUSY is released and goes high. If used as an input, drive BUSY with an open-drain output with a pullup to V_{DDIO} . The processing required for calculating the final DAC code is controlled by an internally generated clock. The clock frequency is not related to any external signals and the frequency is not precisely defined. Therefore, if the DAC must be updated at a precise time with the least amount of jitter, use option 1.

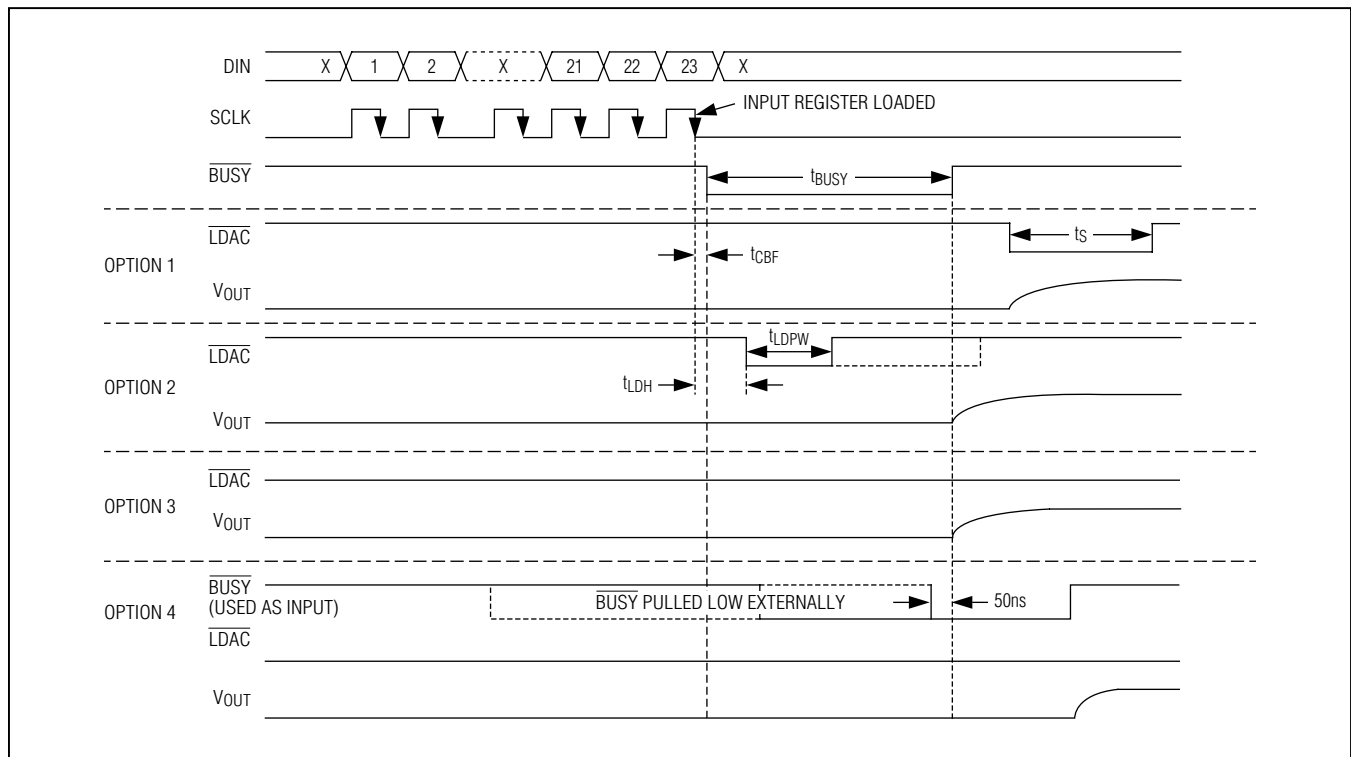

Figure 6. BUSY and LDAC Timing

MAX5318

18-Bit, High-Accuracy Voltage Output DAC with Digital Gain, Offset Control, and SPI Interface

Serial Interface Overview

The SPI interface supports speeds up to 50MHz. When \overline{CS} is high, the remaining interface inputs are disabled to reduce transient currents. The interface supports daisy chaining to enable multiple devices to be controlled on the same SPI bus.

The device has a double-buffered interface consisting of two register banks: the input register and the DAC register. The input register for DIN/GAIN/OFFSET is connected directly to the 24-bit SPI input shift register. The DAC latch contains the DAC code after digital processing and is loaded as defined in the *LDAC and BUSY Interaction* section above.

A valid SPI frame is 24-bit wide with 4-bit command R3 to R0, 18-bit data D17 to D0, and 2 unused LSBs. A full 24-bit SPI command sequence is required for all SPI command operations, regardless of the number of data bits actually used for the command. Any commands terminating with less than a full 24-bit sequence will be aborted without impacting the operation of the part (subject to t_{CSA} timing requirements). Data is not written into the SPI input register or DAC and it continues to hold the preceding valid data. If a command sequence with more than 24 bits is provided, the command will be executed on the 24th SCLK falling edge and the remainder of the command will be ignored.

All SPI commands result in the device assuming control of the DOUT line from the first SCLK edge through the 24th SCLK edge. After relinquishing the DOUT line, the MAX5318 returns to a high-impedance mode. An optional bus hold circuit can be engaged to hold DOUT at its last bit value while not interfering with other devices on the bus.

DOUT is disabled at power-up and must be enabled through the SPI interface. When enabled, DOUT echoes the 4-bit command plus 18-bit data, which is being programmed. During readback, DOUT echoes the 4-bit command followed by the true readback data depending

upon the type of read command. [Table 9](#) shows the bit positions for DOUT and DIN within the 24-bit SPI frame.

The device is designed such that SCLK idles low, and DIN and DOUT change on the rising clock edge and get latched on the falling clock edge. The SPI host controller should be set accordingly.

Daisy-Chain SPI Operation Using \overline{READY} Output

The \overline{READY} pulse appears 24 clock cycles after the negative edge of \overline{CS} as shown in [Figure 7](#) and can therefore be used as the \overline{CS} line for the next device in the daisy chain. Since the device looks at the first 24 bits of the transmission following the falling edge of \overline{CS} , it is possible to daisy-chain the device with different command word lengths. \overline{READY} goes high after \overline{CS} is driven high.

To perform a daisy-chain write operation, drive \overline{CS} low and output the data serially to DIN. The propagation of the \overline{READY} signal then controls how the data is read by the device. As the data propagates through the daisy chain, each individual command in the chain is executed on the 24th falling clock edge following the falling edge of the respective \overline{CS} input. To update just one device in a daisy chain, send the no-op command to the other device in the chain. To update the first device in the chain, raise the \overline{CS} input after writing to that device.

Because daisy-chain operation requires paralleling the DOUTs of all the MAX5318 in the chain, the NO_HOLDEN bit in register 0x4 or 0xC should be set to 1 for all devices. Doing so ensures that DOUT goes into high-impedance after the SPI frame is complete (i.e. after the 24th clock cycle) as shown in [Figure 8](#).

Stand-Alone Operation

The diagram in [Figure 9](#) shows a stand-alone connection of the MAX5318 in a typical SPI application. If more than one peripheral device shares the DOUT bus, the NO_HOLDEN bit in register 0x4 or 0xC should be set to 1 for the MAX5318. Doing so ensures that DOUT goes into high-impedance after the SPI frame is complete (i.e. after the 24th clock cycle).

Table 9. SPI Command and Data Mapping with Clock Falling Edges

CLOCK EDGE	1	2	3	4	5	6	7	8	9	10	11	12	13	14	15	16	17	18	19	20	21	22	23	24
DIN	R3	R2	R1	R0	D17	D16	D15	D14	D13	D12	D11	D10	D9	D8	D7	D6	D5	D4	D3	D2	D1	D0	X	X
DOUT	0	R3	R2	R1	R0	D17	D16	D15	D14	D13	D12	D11	D10	D9	D8	D7	D6	D5	D4	D3	D2	D1	D0	X

Note that 'X' is don't care.

MAX5318

18-Bit, High-Accuracy Voltage Output DAC with Digital Gain, Offset Control, and SPI Interface

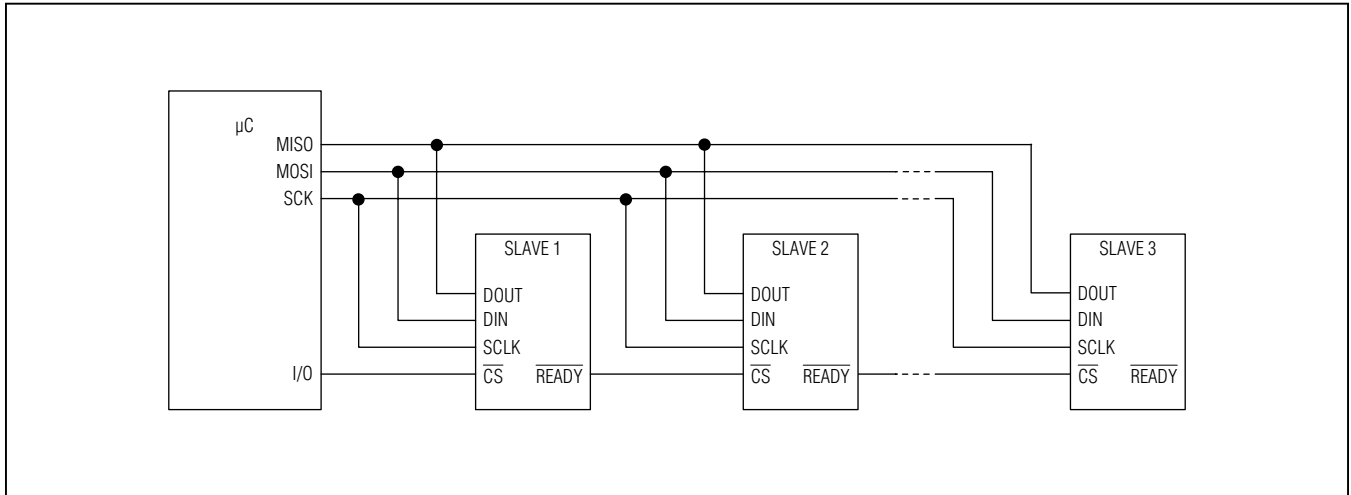

Figure 7. Daisy-Chain SPI Connection Terminating with a Standard SPI Device.

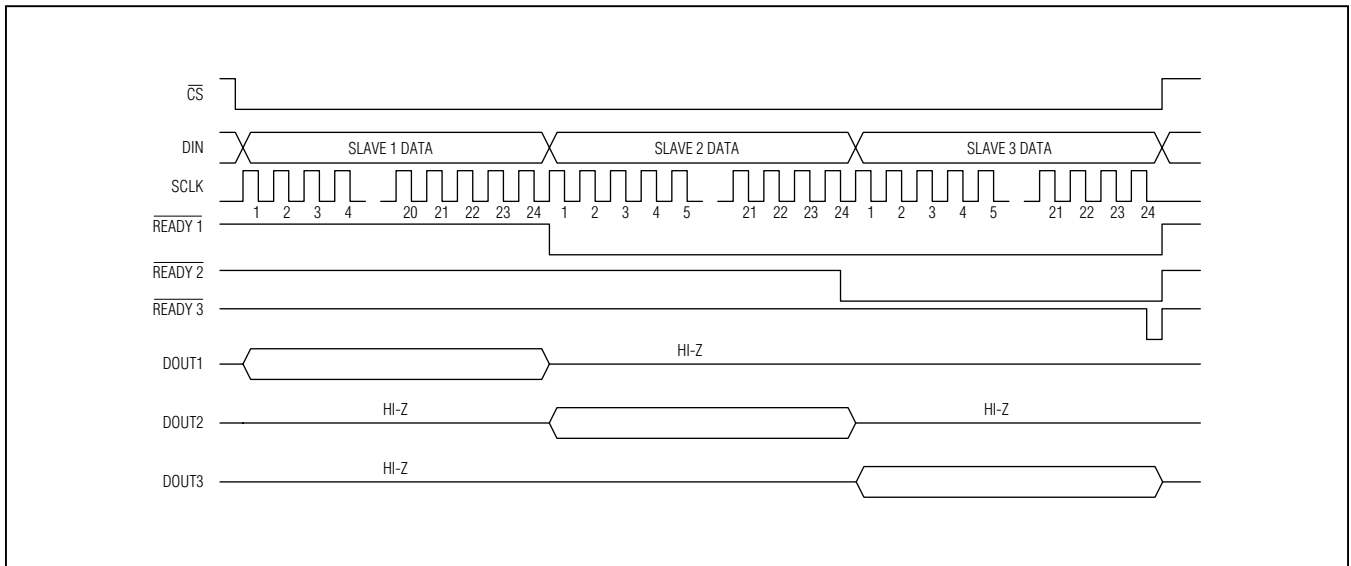

Figure 8. Daisy-Chain SPI Connection Timing

MAX5318

18-Bit, High-Accuracy Voltage Output DAC with Digital Gain, Offset Control, and SPI Interface

Command and Register Map

All command and data registers have read and write functionality. The register selected depends on the command select bits R[3:0]. Each write to the device consists of 4 command select bits (R[3:0]), 18 data bits (which are detailed in [Table 11](#) to [Table 19](#)), and 2 don't care LSBs. A summary of the commands is shown in [Table 10](#).

Applications Information

Power-On Reset (POR)

Upon power-on, the output is set to either zero-scale (if M/\bar{Z} is low) and midscale (if M/\bar{Z} is high). The entire register map is set to their default values as shown in [Table 11](#) to [Table 19](#).

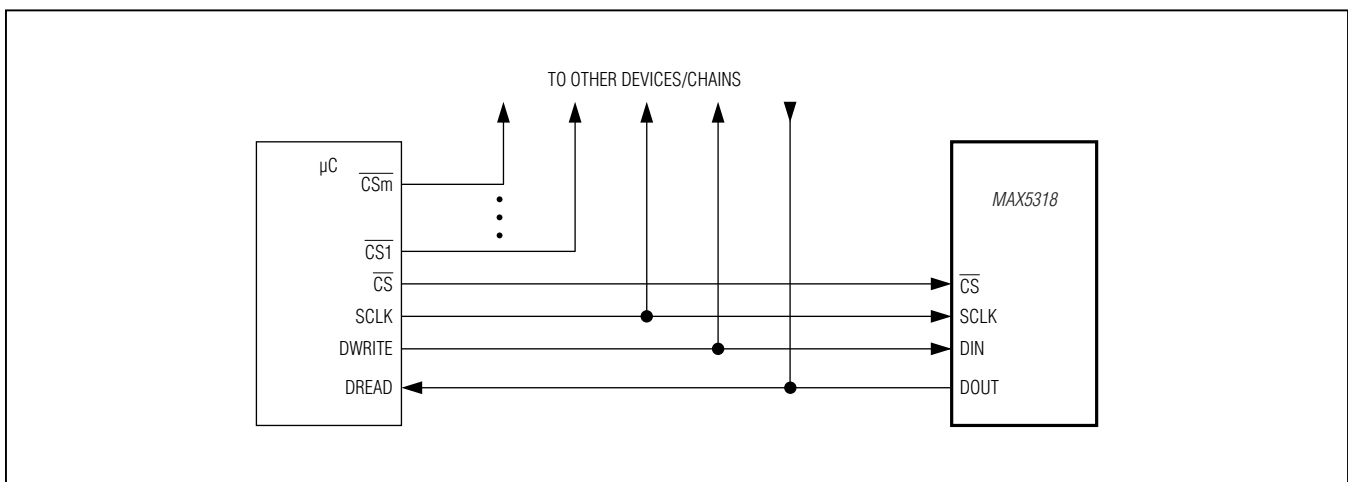

Figure 9. Stand-Alone Operation

Table 10. Register Map Summary

HEX	R3	R2	R1	R0	FUNCTION
0	0	0	0	0	No-op. Used mainly in daisy-chain communications.
1	0	0	0	1	DIN register write
2	0	0	1	0	OFFSET register write
3	0	0	1	1	GAIN register write
4	0	1	0	0	Configuration register write
5-8	—	—	—	—	Reserved
9	1	0	0	1	DIN register read
A	1	0	1	0	OFFSET register read
B	1	0	1	1	GAIN register read
C	1	1	0	0	Configuration and status register read.
D-F	—	—	—	—	Reserved

MAX5318

18-Bit, High-Accuracy Voltage Output DAC with Digital Gain, Offset Control, and SPI Interface

Register Details

Table 11. No-Op Command (0x0)

BIT	17	16	15	14	13	12	11	10	9	8	7	6	5	4	3	2	1	0
NAME	X	X	X	X	X	X	X	X	X	X	X	X	X	X	X	X	X	X
DEFAULT	X	X	X	X	X	X	X	X	X	X	X	X	X	X	X	X	X	X

BIT	NAME	DESCRIPTION
17:0	Don't care	No action on SPI shift register and DAC input registers. Use for daisy-chain purposes when R[3:0] = 0000.

Table 12a. Straight Binary DIN Write Register ($\overline{TC/SB}$) = 0) (0x1)

BIT	17	16	15	14	13	12	11	10	9	8	7	6	5	4	3	2	1	0
NAME	B17	B16	B15	B14	B13	B12	B11	B10	B9	B8	B7	B6	B5	B4	B3	B2	B1	B0
DEFAULT	0x00000 when M/\overline{Z} = DGND (zero scale) 0x20000 when M/\overline{Z} = V_{DDIO} (midscale)																	

BIT	NAME	DESCRIPTION
17:0	B[17:0]	18-bit DAC input code in straight binary format. For clarity, a few examples are shown below: 00 0000 0000 0000 0000 0x00000 zero scale 01 0000 0000 0000 0000 0x10000 quarter scale 10 0000 0000 0000 0000 0x20000 midscale 11 0000 0000 0000 0000 0x30000 three-quarter scale 11 1111 1111 1111 1111 0x3FFFF full scale - 1 LSB

Table 12b. Two's Complement DIN Write Register ($\overline{TC/SB}$) = 1) (0x1)

BIT	17	16	15	14	13	12	11	10	9	8	7	6	5	4	3	2	1	0
NAME	B17	B16	B15	B14	B13	B12	B11	B10	B9	B8	B7	B6	B5	B4	B3	B2	B1	B0
DEFAULT	0x20000 when M/\overline{Z} = DGND (zero scale) 0x00000 when M/\overline{Z} = V_{DDIO} (midscale)																	

BIT	NAME	DESCRIPTION
17:0	B[17:0]	18-bit DAC input code in two's complement format. For clarity, a few examples are shown below: 10 0000 0000 0000 0000 0x20000 zero scale 11 0000 0000 0000 0000 0x30000 quarter scale 11 1111 1111 1111 1111 0x3FFFF midscale - 1 LSB 00 0000 0000 0000 0000 0x00000 midscale 00 0000 0000 0000 0001 0x00001 midscale + 1 LSB 01 0000 0000 0000 0000 0x10000 three-quarter scale 01 1111 1111 1111 1111 0x1FFFF full scale - 1 LSB

MAX5318

18-Bit, High-Accuracy Voltage Output DAC with Digital Gain, Offset Control, and SPI Interface

Table 13. OFFSET Register Write in Two's Complement (0x2)

BIT	17	16	15	14	13	12	11	10	9	8	7	6	5	4	3	2	1	0
NAME	B17	B16	B15	B14	B13	B12	B11	B10	B9	B8	B7	B6	B5	B4	B3	B2	B1	B0
DEFAULT	0x00000—Zero Offset																	

BIT	NAME	DESCRIPTION
17:0	B[17:0]	18-bit offset code in two's complement format. For clarity, a few examples are shown below: 10 0000 0000 0000 0000 0x20000 offset of -2^{17} 11 1111 1111 1111 1111 0x3FFFF offset of -1 00 0000 0000 0000 0000 0x00000 offset of 0 00 0000 0000 0000 0001 0x00001 offset of +1 01 1111 1111 1111 1111 0x1FFFF offset of $2^{17} - 1$

Table 14. GAIN Write Register (0x3)

BIT	17	16	15	14	13	12	11	10	9	8	7	6	5	4	3	2	1	0
NAME	B17	B16	B15	B14	B13	B12	B11	B10	B9	B8	B7	B6	B5	B4	B3	B2	B1	B0
DEFAULT	0x3FFFF—Gain of 1																	

BIT	NAME	DESCRIPTION
17:0	B[17:0]	18-bit gain code. For clarity, a few examples are shown below: 11 1111 1111 1111 1111 3FFFFh Gain of 1. $(2^{18} - 1 + 1)/2^{18}$ 11 1111 1111 1111 1110 3FFFEh Gain of 0.999996. $(2^{18} - 2 + 1)/2^{18}$ 01 1111 1111 1111 1111 1FFFFh Gain of 0.5. $(2^{17} - 1 + 1)/2^{18}$ 01 1111 1111 1111 1110 1FFFEh Gain of 0.499996. $(2^{17} - 2 + 1)/2^{18}$ 00 0000 0000 0000 0000 00000h Gain of 0.0000076. $1/2^{18}$

MAX5318

18-Bit, High-Accuracy Voltage Output DAC with Digital Gain, Offset Control, and SPI Interface

Table 15. General Configuration Write Register (0x4)

BIT	17	16	15	14	13	12	11	10	9	8	7	6	5	4	3	2	1	0
NAME	PD_SW	NO_HOLDEN	$\overline{\text{RST_SW}}$	$\overline{\text{NO_BUSY}}$	DOUT_ON	X	X	X	X	X	X	X	X	X	X	X	X	X
DEFAULT	0	0	1	0	0	X	X	X	X	X	X	X	X	X	X	X	X	X

BIT	NAME	DESCRIPTION
17	PD_SW	Software PD (Power-Down). Equivalent to the PD input. 0: Normal mode 1: Power-down mode. OUT is internally connected to AGND using a 2kΩ resistor.
16	NO_HOLDEN	SPI Bus Hold Enable. 0: Bus hold enabled for SPI DOUT output. DOUT stays at its last value after the SPI $\overline{\text{CS}}$ input rises at the end of the SPI frame (i.e. after the 24th clock cycle). 1: Bus hold disabled for SPI DOUT output. DOUT goes high impedance after the SPI $\overline{\text{CS}}$ input rises at the end of the SPI frame (i.e. after the 24th clock cycle).
15	$\overline{\text{RST_SW}}$	Software Reset. Equivalent to the $\overline{\text{RST}}$ input. 0: Place device in reset 1: Normal operation Set the active low $\overline{\text{RST_SW}}$ bit low to initiate a software reset (equivalent to pulling $\overline{\text{RST}}$ low)
14	$\overline{\text{NO_BUSY}}$	$\overline{\text{BUSY}}$ Input Disable. 0: $\overline{\text{BUSY}}$ input is active. 1: $\overline{\text{BUSY}}$ input is disabled. Note that this does not affect the $\overline{\text{BUSY}}$ bit in the General Configuration and Status Register. The $\overline{\text{BUSY}}$ pin is bidirectional. When enabled, it can be pulled down externally to delay DAC updates.
13	DOUT_ON	SPI DOUT Output Disable. DOUT is disabled by default. 0: DOUT output disabled. When DOUT is disabled, the output is pulled low for the duration of the SPI frame. 1: DOUT output enabled.
12:0	—	Don't care. These bits are reserved for the corresponding read command.

MAX5318

18-Bit, High-Accuracy Voltage Output DAC with Digital Gain, Offset Control, and SPI Interface

Table 16. DIN Read Register (0x9)

BIT	17	16	15	14	13	12	11	10	9	8	7	6	5	4	3	2	1	0
NAME	B17	B16	B15	B14	B13	B12	B11	B10	B9	B8	B7	B6	B5	B4	B3	B2	B1	B0
DEFAULT	0	0	0	0	0	0	0	0	0	0	0	0	0	0	0	0	0	0

BIT	NAME	DESCRIPTION
17:0	B[17:0]	18-bit DIN readback value.

Table 17. OFFSET Read Register (0xA)

BIT	17	16	15	14	13	12	11	10	9	8	7	6	5	4	3	2	1	0
NAME	B17	B16	B15	B14	B13	B12	B11	B10	B9	B8	B7	B6	B5	B4	B3	B2	B1	B0
DEFAULT	0	0	0	0	0	0	0	0	0	0	0	0	0	0	0	0	0	0

BIT	NAME	DESCRIPTION
17:0	B[17:0]	18-bit OFFSET readback value in two's complement.

Table 18. GAIN Read Register (0xB)

BIT	17	16	15	14	13	12	11	10	9	8	7	6	5	4	3	2	1	0
NAME	B17	B16	B15	B14	B13	B12	B11	B10	B9	B8	B7	B6	B5	B4	B3	B2	B1	B0
DEFAULT	1	1	1	1	1	1	1	1	1	1	1	1	1	1	1	1	1	1

BIT	NAME	DESCRIPTION
17:0	B[17:0]	18-bit GAIN readback value.

MAX5318

18-Bit, High-Accuracy Voltage Output DAC with Digital Gain, Offset Control, and SPI Interface

Table 19. General Configuration and Status Read Register (0xC)

BIT	17	16	15	14	13	12	11	10	9	8	7	6	5	4	3	2	1	0
NAME	PD_SW	NO_HOLDEN	$\overline{\text{RST_SW}}$	$\overline{\text{NO_BUSY}}$	DOUT_ON	$\overline{\text{BUSY}}$	X	X	X	X	X	X	REV_ID[3:0]			X	X	
DEFAULT	0	0	1	0	0	0	0	0	0	0	0	0	0001			0	0	

BIT	NAME	DESCRIPTION
17	PD_SW	Software PD (Power-Down). Equivalent to the PD input. 0: Normal mode. 1: Power-down mode. OUT is internally connected to AGND using a 2kΩ resistor.
16	NO_HOLDEN	SPI Bus Hold Enable. 0: Bus hold enabled for SPI DOUT output. DOUT stays at its final value after the SPI $\overline{\text{CS}}$ input rises at the end of the SPI frame. 1: Bus hold disabled for SPI DOUT output. DOUT goes high impedance after the SPI $\overline{\text{CS}}$ input rises at the end of the SPI frame.
15	$\overline{\text{RST_SW}}$	Software Reset. Equivalent to the $\overline{\text{RST}}$ input. 0: Place device in reset. 1: Normal operation. Set the active low $\overline{\text{RST_SW}}$ bit low to initiate a software reset (equivalent to pulling $\overline{\text{RST}}$ low).
14	$\overline{\text{NO_BUSY}}$	$\overline{\text{BUSY}}$ Input Disable. 0: $\overline{\text{BUSY}}$ input is active. 1: $\overline{\text{BUSY}}$ input is disabled. Note that this does not affect the $\overline{\text{BUSY}}$ bit in the General Configuration and Status Register. The $\overline{\text{BUSY}}$ pin is bidirectional. When enabled, it can be pulled down externally to delay DAC updates.
13	DOUT_ON	SPI DOUT Output Disable. DOUT is disabled by default. 0: DOUT output disabled. When DOUT is disabled, the output is pulled low for the duration of the SPI frame. 1: DOUT output enabled.
12	$\overline{\text{BUSY}}$	Global $\overline{\text{BUSY}}$ status readback. 0: Device is busy calculating output voltage. 1: Device is not busy.
11:6	—	Reserved. Will read back 0.
5:2	REV_ID[3:0]	Device revision
1:0	—	Reserved. Will read back 0.

MAX5318

18-Bit, High-Accuracy Voltage Output DAC with Digital Gain, Offset Control, and SPI Interface

Power Supplies and Bypassing Considerations

For best performance, use a separate supply for the MAX5318. Bypass V_{DDIO} , $AVDD_{-}$, and $AVSS$ with high-quality ceramic capacitors to a low-impedance ground as close as possible to the device. A typical high-quality X5R $10\mu\text{F}$ capacitor can become self resonant at 2MHz. Therefore, it is actually an inductor above 2MHz and is useless for decoupling signals above 2MHz. It is therefore recommended that several capacitors of different values are connected in parallel. Figure 10 shows the magnitude of impedance of typical $1\mu\text{F}$, 100nF , and 10nF X5R capacitors. As the capacitance reduces, the self-resonant frequency increases. In addition, the parallel combination of all three is shown and exhibits a significant improvement over a single capacitor. These plots do not include any PCB trace inductance.

Minimize lead lengths to reduce lead inductance. Adding just 2nH trace inductance to each of the typical capacitors above produces the effects shown in Figure 11. This shows significant reduction in the self-resonant frequencies of the capacitors.

Internal Linear Regulator (BYPASS)

BYPASS is the output of an internal linear regulator and is used to power digital circuitry. Connect BYPASS to DGND with a ceramic capacitor in the range of $1\mu\text{F}$ to $10\mu\text{F}$ with ESR in the range of $100\text{m}\Omega$ to $20\text{m}\Omega$ to ensure stability. The typical voltage on this pin is 2.4V. Use a low-leakage capacitor to ensure low power-down current.

Power-Supply Sequencing

During power-up, ensure that $AVDD_{-}$ comes up before the reference does. If this is not possible, connect a Schottky diode between the REF and $AVDD_{-}$ such as the MBR0530T1G. If REF does come up before $AVDD_{-}$, the diode conducts and clamps REF to $AVDD_{-}$. Once $AVDD_{-}$ has come up, the diode no longer conducts. REF should always be below $AVDD_{-}$ as specified in the *Electrical Characteristics*. $AVDD_{-}$ and $AVSS$ should be connected together and powered from the same supply. V_{DDIO} and $AVSS$ can be sequenced in any order. Always perform a reset operation after all the supplies are brought up to place the device in a known operating state.

Layout Considerations

Digital and AC transient signals on AGND inputs can create noise at the outputs. Connect both AGND inputs to form the star ground for the DAC system. Refer remote DAC loads to this system ground for the best possible performance (see the *Force/Sense* section).

Use proper grounding techniques, such as a multilayer board with a low-inductance ground plane, or star connect all ground return paths back to AGND. Do not use wire-wrapped boards and sockets. Use ground plane shielding to improve noise immunity. Do not run analog and digital signals parallel to one another (especially clock signals) and avoid routing digital lines underneath the device package.

For a recommended layout, consult the MAX5318 Evaluation Kit datasheet.

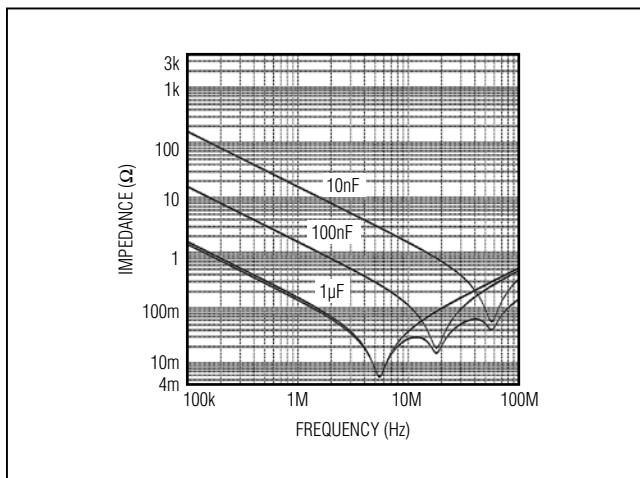

Figure 10. Typical X5R Capacitor Impedance

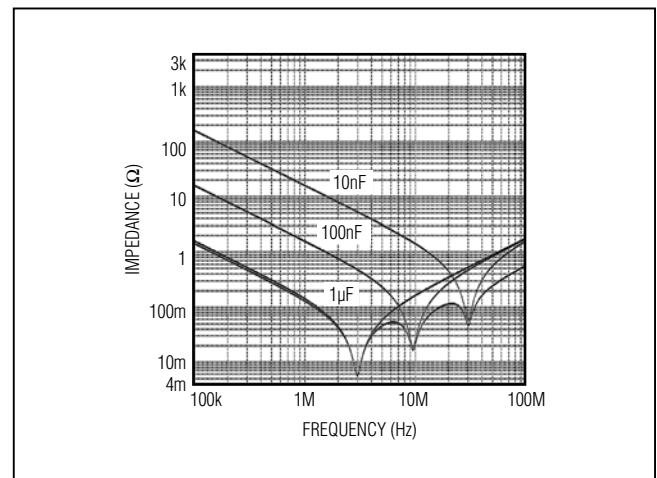

Figure 11. Typical X5R Capacitor Impedance with Additional 2nH PCB Trace Inductance

MAX5318

18-Bit, High-Accuracy Voltage Output DAC with Digital Gain, Offset Control, and SPI Interface

Voltage Reference Selection and Layout

The voltage reference should be placed close to the DAC. The same power-supply decoupling and grounding rules as the DAC should be implemented. Many voltage references require an output capacitor for stability or noise reduction. Provided the trace between the reference device and the DAC is kept short and well shielded, a single capacitor may be used and placed close to the DAC. However, for improved noise immunity, additional capacitors may be used but be careful not to exceed the recommended capacitance range for the voltage reference.

Refer to Maxim Applications Note AN4300: *Calculating the Error Budget in Precision Digital-to-Analog Converter (DAC) Applications* for detailed description of voltage reference parameters and trading off the error budget. The MAX6126 is recommended for use with this device.

Optimizing Data Throughput Rate

The *LDAC and BUSY Interaction* section details the timing of data written to the device and how the DAC is updated. Data throughput speed can be increased by overlapping the data load time with the calibration and settling time as shown below in [Figure 12](#). Following the 24th SCLK falling edge, the device starts its calibration period. Providing that the $\overline{\text{LDAC}}$ falling edge arrives before the 24th SCLK falling edge, and assuming the SPI clock frequency is high enough, the throughput period is therefore limited by the internal calculation and settling times only. A slight further increase in throughput time can be gained by either toggling $\overline{\text{LDAC}}$ during the calculation time or by pulling it low permanently. However,

the exact point at which the DAC update occurs is then determined internally as indicated by the $\overline{\text{BUSY}}$ line rising edge. This is not an exact time.

BUSY Line Pullup Resistor Selection

The $\overline{\text{BUSY}}$ pin is an open-drain output. It therefore requires a pullup resistor. $2\text{k}\Omega$ value is recommended as a compromise between power and speed. Stray capacitance on this line can easily slow the rise time to an unacceptable level. The $\overline{\text{BUSY}}$ pin can sink up to 5mA . Therefore a resistor as low as $V_{\text{DDIO}}/0.005$ may be used if faster rise times are required.

Producing Unipolar High-Voltage and Bipolar Outputs

[Figure 11](#) and [Figure 12](#) show how external op amps can be used to produce a unipolar high-voltage output and a bipolar output

Definitions

Integral Nonlinearity (INL)

INL is the deviation of the measured transfer function from a straight line drawn between two codes. This line is drawn between the zero and full-scale codes of the transfer function, once offset and gain errors have been nullified.

Differential Nonlinearity (DNL)

DNL is the difference between an actual step height and the ideal value of 1 LSB. If the magnitude of the DNL is less than or equal to 1 LSB, the DAC guarantees no missing codes and is monotonic.

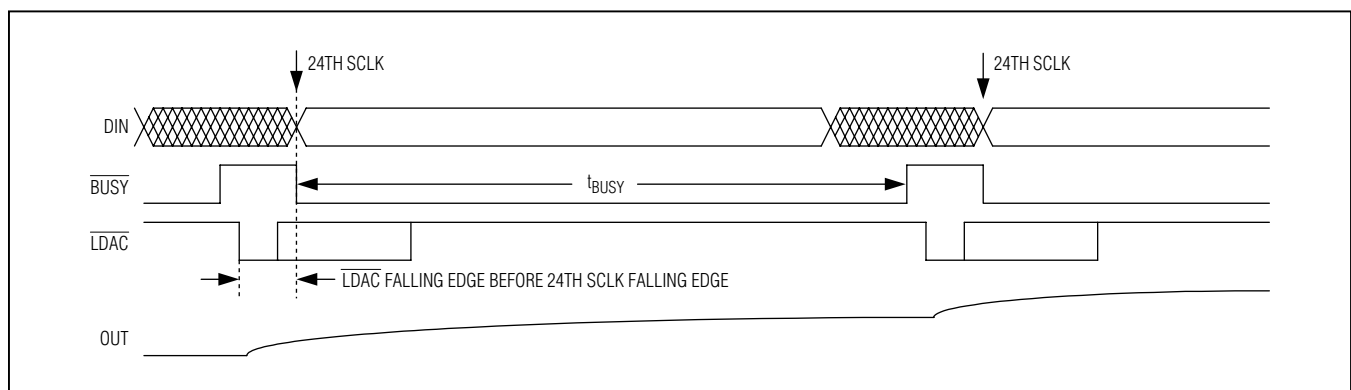

Figure 12. Optimum Throughput with Stable Update Period

MAX5318

18-Bit, High-Accuracy Voltage Output DAC with Digital Gain, Offset Control, and SPI Interface

Offset Error

Offset error indicates how well the actual transfer function matches the ideal transfer function at a single point. Typically, the point at which the offset error is specified is at or near the zero-scale point of the transfer function.

Gain Error

Gain error is the difference between the ideal and the actual full-scale output voltage on the transfer curve, after nullifying the offset error. This error alters the slope of the transfer function and corresponds to the same percentage error in each step.

Settling Time

The settling time is the amount of time required from the start of a $\overline{\text{LDAC}}$ high-to-low transition or $\overline{\text{BUSY}}$ low-to-high transition (whichever occurs last), until the DAC output settles to within 0.003% of the final value.

Digital Feedthrough

Digital feedthrough is the amount of noise that appears on the DAC output when the DAC digital control lines are toggled.

Digital-to-Analog Glitch Impulse

The glitch impulse occurs at the major carry transitions along the segmented bit boundaries. It is specified as the net area of the glitch impulse which appears at the output when the digital input code changes by 1 LSB. The glitch impulse is specified in nanovolts-seconds (nV-s).

Digital-to-Analog Power-Up Glitch Impulse

The digital-to-analog power-up glitch is the net area of the glitch impulse which appears at the output when the device exits power-down mode.

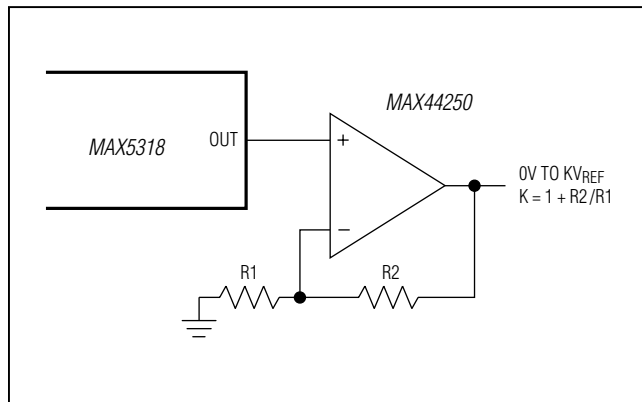

Figure 13. Unipolar High-Voltage Output

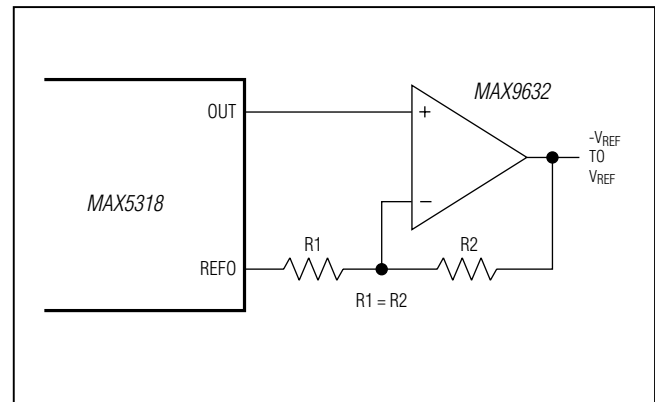
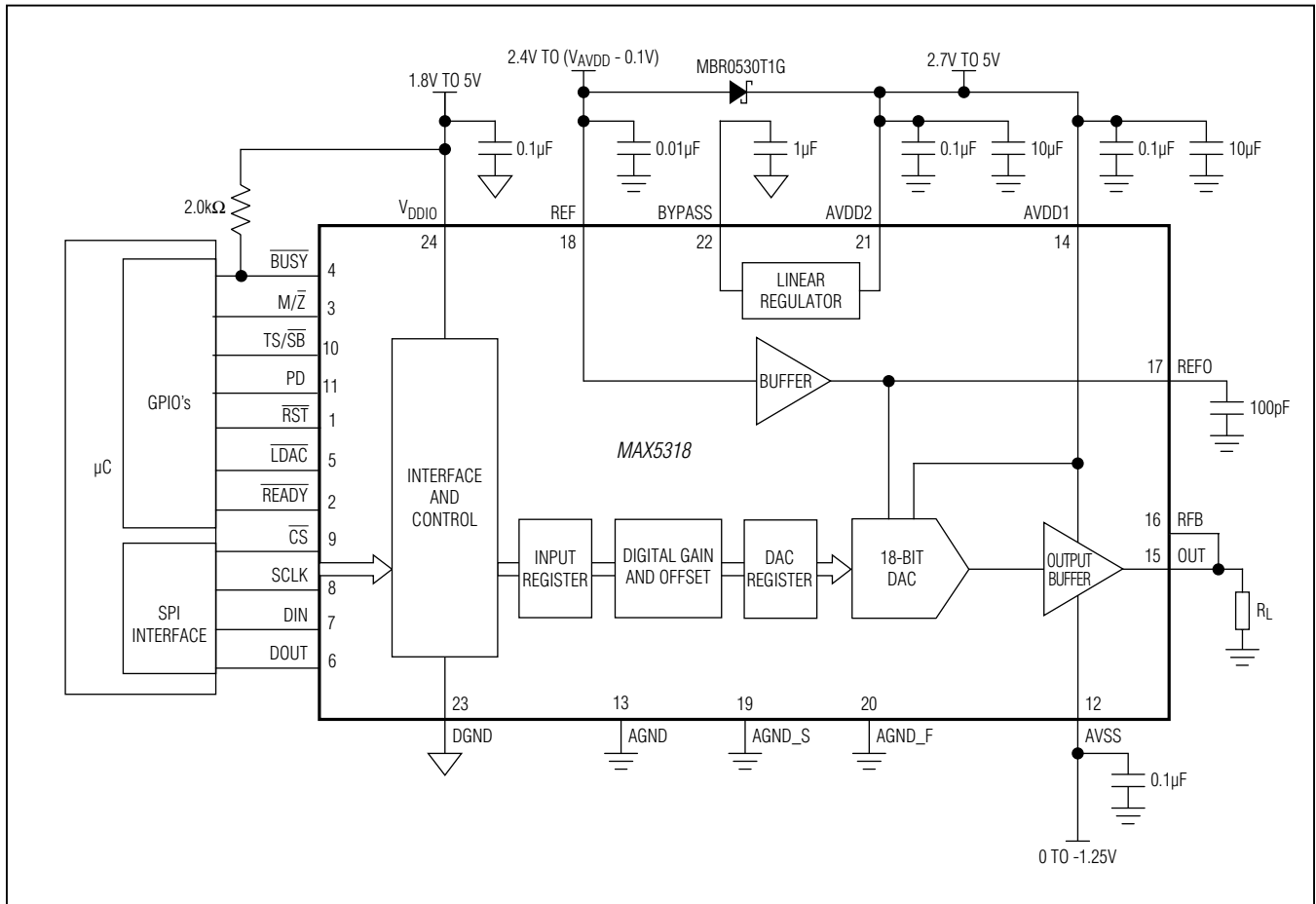

Figure 14. Bipolar Output

MAX5318

18-Bit, High-Accuracy Voltage Output DAC with Digital Gain, Offset Control, and SPI Interface

Typical Operating Circuit



Ordering Information

PART	TEMP RANGE	PIN-PACKAGE
MAX5318GUG+	-40°C to +105°C	24 TSSOP

+Denotes a lead(Pb)-free/RoHS-compliant package.

Chip Information

PROCESS: BiCMOS

Package Information

For the latest package outline information and land patterns (footprints), go to www.maximintegrated.com/packages. Note that a "+", "#", or "-" in the package code indicates RoHS status only. Package drawings may show a different suffix character, but the drawing pertains to the package regardless of RoHS status.

PACKAGE TYPE	PACKAGE CODE	OUTLINE NO.	LAND PATTERN NO.
24 TSSOP	U24+1	21-0066	90-0118

MAX5318

18-Bit, High-Accuracy Voltage Output DAC with Digital Gain, Offset Control, and SPI Interface

Revision History

REVISION NUMBER	REVISION DATE	DESCRIPTION	PAGES CHANGED
0	9/12	Initial release	—



Maxim cannot assume responsibility for use of any circuitry other than circuitry entirely embodied in a Maxim product. No circuit patent licenses are implied. Maxim reserves the right to change the circuitry and specifications without notice at any time. The parametric values (min and max limits) shown in the Electrical Characteristics table are guaranteed. Other parametric values quoted in this data sheet are provided for guidance.

Maxim Integrated 160 Rio Robles, San Jose, CA 95134 USA 1-408-601-1000

41

Looking for pricing, stock, or lifecycle information?

Click below to explore more details on WIN SOURCE:

 [View MAX5318GUG+ on WIN SOURCE](#)

 [Maxim Integrated Information](#)

Optimize Your Supply Chain with WIN SOURCE Solutions

-  Global Sourcing Solution
-  Obsolete Management
-  Cost Control Management
-  Shortage Management
-  Alternative Solution
-  Excess Inventory Management