



**THE DATASHEET OF
MAX4481AUT+T**



MAX4480–MAX4483

Single/Dual/Quad, Low-Cost, Single-Supply, Rail-to-Rail Op Amps with Shutdown

General Description

The MAX4480–MAX4483 low-cost, general-purpose op amps offer rail-to-rail outputs, draw only 50 μ A of quiescent current, and operate from a single +2.5V to +5.5V supply. For additional power conservation, the MAX4481 offers a low-power shutdown mode that reduces supply current to 0.5 μ A (max) and puts the amplifier's output in a high-impedance state. These devices are unity-gain stable with capacitive loads up to 400pF. The MAX4480–MAX4483 are specified to +125°C, making them suitable for use in a variety of harsh environments.

The MAX4480 is a single amplifier offered in a tiny 5-pin SC70 package. The MAX4481 is a single amplifier with a low-power shutdown mode that reduces supply current to < 0.5 μ A and comes in a 6-pin SC70 package. The MAX4482 is a dual amplifier and comes in the space-saving 8-pin SOT23 or μ MAX® package. The MAX4483 is a quad amplifier and comes in a 14-pin TSSOP package. All devices are specified for operation across the -40°C to +125°C automotive temperature range.

Applications

- Single-Supply Zero-Crossing Detectors
- Instruments and Terminals
- Portable Communications
- Electronic Ignition Modules
- Infrared Receivers
- Sensor Signal Detection

Selector Guide

| PART | NO. OF AMPLIFIERS PER PACKAGE | SHUTDOWN MODE |
|---------|-------------------------------|---------------|
| MAX4480 | 1 | No |
| MAX4481 | 1 | Yes |
| MAX4482 | 2 | No |
| MAX4483 | 4 | No |

μ MAX is a registered trademark of Maxim Integrated Products, Inc.

Features

- Single +2.5V to +5.5V Supply Voltage Range
- 50 μ A Quiescent Current per Amplifier
- 0.5 μ A (max) Shutdown Mode (MAX4481)
- Available in Space-Saving Packages
 - 5-Pin SC70 (MAX4480)
 - 6-Pin SC70 (MAX4481)
 - 8-Pin SOT23 (MAX4482)
- 105dB AV_{OL} with 5k Ω Load
- 0.005% THD with 100k Ω Load
- Rail-to-Rail Output Voltage Swing
- 3.0mA of Sink and Source Load Current
- Unity-Gain Stable up to $C_{LOAD} = 400$ pF

Ordering Information

| PART | TEMP RANGE | PIN-PACKAGE | TOP MARK |
|-----------------|-----------------|-------------|----------|
| MAX4480AXK+T | -40°C to +125°C | 5 SC70 | ABU |
| MAX4480AUK+T | -40°C to +125°C | 5 SOT23 | ADPJ |
| MAX4481AXT+T | -40°C to +125°C | 6 SC70 | AAN |
| MAX4481AUT+T | -40°C to +125°C | 6 SOT23 | AAOS |
| MAX4481MXT/PR3+ | -55°C to +110°C | 6 SC70 | AEE |
| MAX4482AKA+T | -40°C to +125°C | 8 SOT23 | AAEJ |
| MAX4482ASA+ | -40°C to +125°C | 8 SO | — |
| MAX4482AUA+ | -40°C to +125°C | 8 FMAX | — |
| MAX4483ASD+ | -40°C to +125°C | 14 SO | — |
| MAX4483AUD+ | -40°C to +125°C | 14 TSSOP | — |

+Denotes a lead(Pb)-free/RoHS-compliant package.
T = Tape and reel.

Pin Configurations

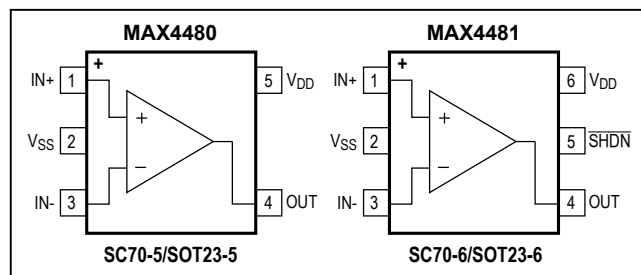

Pin Configurations continued at end of data sheet.

Absolute Maximum Ratings

| | | | |
|---|--------------|--|-----------------|
| Power-Supply Voltage (V_{DD} to V_{SS})..... | -0.3V to +6V | 8-Pin μ MAX (derate 4.5mW/°C above +70°C)..... | 362mW |
| All Other Pins.....($V_{SS} - 0.3V$) to ($V_{DD} + 0.3V$) | | 8-Pin SO (derate 5.9mW/°C above +70°C)..... | 471mW |
| Output Short-Circuit Duration | | 14-Pin TSSOP (derate 9.1mW/°C above +70°C)..... | 727mW |
| (OUT shorted to V_{SS} or V_{DD})..... | Continuous | 14-Pin SO (derate 8.33mW/°C above +70°C)..... | 667mW |
| Continuous Power Dissipation ($T_A = +70^\circ\text{C}$) | | Operating Temperature Range | -40°C to +125°C |
| 5-Pin SC70 (derate 3.1mW/°C above +70°C)..... | 247mW | Military Operating Temperature Range..... | -55°C to +110°C |
| 6-Pin SC70 (derate 3.1mW/°C above +70°C)..... | 245mW | Junction Temperature..... | 150°C |
| 5-Pin SOT23 (derate 3.1mW/°C above +70°C)..... | 247mW | Storage Temperature Range..... | -65°C to +150°C |
| 6-Pin SOT23 (derate 8.7mW/°C above +70°C)..... | 696mW | Lead Temperature (soldering, 10s)..... | +3000°C |
| 8-Pin SOT23 (derate 5.1mW/°C above +70°C)..... | 408mW | Soldering Temperature (reflow)..... | +240°C |

Stresses beyond those listed under "Absolute Maximum Ratings" may cause permanent damage to the device. These are stress ratings only, and functional operation of the device at these or any other conditions beyond those indicated in the operational sections of the specifications is not implied. Exposure to absolute maximum rating conditions for extended periods may affect device reliability.

Electrical Characteristics

($V_{DD} = +5V$, $V_{SS} = 0V$, $V_{CM} = 0V$, $V_{OUT} = V_{DD}/2$, $R_L \geq 1M\Omega$ connected to $V_{DD}/2$, $\overline{SHDN} = V_{DD}$ (MAX4481 only), $T_A = +25^\circ\text{C}$, unless otherwise noted.)

| PARAMETER | SYMBOL | CONDITIONS | MIN | TYP | MAX | UNITS |
|---------------------------------|------------------|---|---------------------|------------|---------------------|---------------|
| Supply Voltage Range | V_{DD} | Inferred from PSRR test | 2.5 | | 5.5 | V |
| Supply Current per Amplifier | I_{DD} | $V_{DD} = 2.5V$ | | 45 | | μA |
| | | $V_{DD} = 5.0V$ | | 50 | 100 | |
| Supply Current in Shutdown | I_{SHDN} | $\overline{SHDN} = V_{SS}$ (MAX4481 only) | | 0.05 | 0.5 | μA |
| Input Offset Voltage | V_{OS} | | | ± 1 | ± 5.5 | mV |
| Input Bias Current | I_B | (Note 1) | | ± 0.1 | ± 100 | pA |
| Input Offset Current | I_{OS} | (Note 1) | | ± 0.1 | ± 100 | pA |
| Input Resistance | R_{IN} | Differential or common mode | | 1000 | | M Ω |
| Input Common-Mode Voltage Range | V_{CM} | Inferred from CMRR test | V_{SS} | | $V_{DD} - 1.3$ | V |
| Common-Mode Rejection Ratio | CMRR | $V_{SS} \leq V_{CM} \leq V_{DD} - 1.3V$ | 71 | 86 | | dB |
| Power-Supply Rejection Ratio | PSRR | $2.5V \leq V_{DD} \leq 5.5V$ | 82 | 92 | | dB |
| Large-Signal Voltage Gain | A_{VOL} | $V_{SS} + 0.02V \leq V_{OUT} \leq V_{DD} - 0.03V$ $R_L = 100k\Omega$ | | 110 | | dB |
| | | $V_{SS} + 0.10V \leq V_{OUT} \leq V_{DD} - 0.20V$ $R_L = 5k\Omega$ | 94 | 105 | | |
| Output Voltage High | V_{OH} | Specified as $V_{DD} - V_{OUT}$ | $R_L = 100k\Omega$ | 4 | | mV |
| | | | $R_L = 5k\Omega$ | 80 | 150 | |
| Output Voltage Low | V_{OL} | Specified as $V_{OUT} - V_{SS}$ | $R_L = 100k\Omega$ | 1 | | mV |
| | | | $R_L = 5k\Omega$ | 8 | 30 | |
| Output Short-Circuit Current | I_{SC} | Sourcing | | 3 | | mA |
| | | Sinking | | 17 | | |
| Shutdown Mode Output Leakage | $I_{OUTSHDN}$ | Device in shutdown mode, $\overline{SHDN} = V_{SS}$, $V_{SS} < V_{OUT} < V_{CC}$ (MAX4481 only) | | ± 0.01 | ± 0.1 | μA |
| \overline{SHDN} Logic Low | V_{IL} | MAX4481 only | | | $0.3 \times V_{DD}$ | V |
| \overline{SHDN} Logic High | V_{IH} | MAX4481 only | $0.7 \times V_{DD}$ | | | V |
| \overline{SHDN} Input Current | I_{IL}, I_{IH} | $\overline{SHDN} = V_{DD}$ or V_{SS} (MAX4481 only) | ± 0.001 | ± 1 | ± 500 | nA |
| Gain-Bandwidth Product | GBW | | | 140 | | kHz |

Electrical Characteristics (continued)

($V_{DD} = +5V$, $V_{SS} = 0V$, $V_{CM} = 0V$, $V_{OUT} = V_{DD}/2$, $R_L \geq 1M\Omega$ connected to $V_{DD}/2$, $\overline{SHDN} = V_{DD}$ (MAX4481 only), $T_A = +25^\circ C$, unless otherwise noted.)

| PARAMETER | SYMBOL | CONDITIONS | | MIN | TYP | MAX | UNITS |
|-----------------------------|------------|--|--------------------|-----|-------|-----|-----------------|
| Phase Margin | ϕ_M | | | | 70 | | degrees |
| Gain Margin | | | | | 30 | | dB |
| Slew Rate | SR | | | | 80 | | V/ms |
| Input Voltage Noise Density | e_n | f = 10kHz | | | 100 | | nV/ \sqrt{Hz} |
| Input Current Noise Density | i_n | f = 10kHz | | | 1 | | nV/ \sqrt{Hz} |
| Capacitive-Load Stability | C_{LOAD} | $A_V = +1V/V$ | | | 400 | | pF |
| Shutdown Delay Time | t_{SHDN} | MAX4481 only | | | 0.4 | | μs |
| Enable Delay Time | t_{EN} | MAX4481 only | | | 12 | | μs |
| Power-On Time | t_{ON} | | | | 15 | | μs |
| Input Capacitance | C_{IN} | | | | 2.0 | | pF |
| Total Harmonic Distortion | THD | f = 1kHz, $V_{OUT} = 2V_{P-P}$, $A_V = +1V/V$ | $R_L = 100k\Omega$ | | 0.005 | | % |
| Settling Time to 0.1% | t_S | $V_{OUT} = 2V$ step | | | 50 | | μs |

Electrical Characteristics

($V_{DD} = +5V$, $V_{SS} = 0V$, $V_{CM} = 0V$, $V_{OUT} = V_{DD}/2$, $R_L \geq 1M\Omega$ connected to $V_{DD}/2$, $\overline{SHDN} = V_{DD}$ (MAX4481 only), $T_A = -40^\circ C$ to $+125^\circ C$, unless otherwise noted.)

| PARAMETER | SYMBOL | CONDITIONS | | MIN | TYP | MAX | UNITS |
|---------------------------------|------------------|--|--|---------------------|---------|---------------------|------------------|
| Supply Voltage Range | V_{DD} | Inferred from PSRR test | | 2.5 | | 5.5 | V |
| Supply Current per Amplifier | I_{DD} | | | | | 120 | μA |
| Supply Current in Shutdown | I_{SHDN} | $\overline{SHDN} = V_{SS}$ (MAX4481 only) | | | | 1.0 | μA |
| Input Offset Voltage | V_{OS} | | | | | 9 | mV |
| Input Offset Voltage Drift | TCV_{OS} | | | | ± 3 | | $\mu V/^\circ C$ |
| Input Bias Current | I_B | (Note 1) | | | | ± 100 | pA |
| Input Offset Current | I_{OS} | (Note 1) | | | | ± 100 | pA |
| Input Common-Mode Voltage Range | V_{CM} | Inferred from CMRR test | | V_{SS} | | $V_{DD} - 1.4$ | V |
| Common-Mode Rejection Ratio | CMRR | $V_{SS} \leq V_{CM} \leq V_{DD} - 1.4V$ | | 67 | | | dB |
| Power-Supply Rejection Ratio | PSRR | $2.5V \leq V_{DD} \leq 5.5V$ | | 77 | | | dB |
| Shutdown Mode Output Leakage | $I_{OUTSHDN}$ | Device in shutdown mode, $\overline{SHDN} = V_{SS}$, $V_{SS} < V_{OUT} < V_{CC}$ (MAX4481 only) | | -40°C to +85°C | | ± 0.5 | μA |
| | | | | +85°C to +125°C | | ± 2.5 | |
| \overline{SHDN} Logic Low | V_{IL} | MAX4481 only | | | | $0.3 \times V_{DD}$ | V |
| \overline{SHDN} Logic High | V_{IH} | MAX4481 only | | $0.7 \times V_{DD}$ | | | V |
| \overline{SHDN} Input Current | I_{IL}, I_{IH} | $\overline{SHDN} = V_{DD}$ or V_{SS} (MAX4481 only) | | | | 1 | μA |
| Large-Signal Voltage Gain | A_{VOL} | $V_{SS} + 0.1V \leq V_{OUT} \leq V_{DD} - 0.20V$, $R_L = 5k\Omega$ | | 84 | | | dB |
| Output Voltage High | V_{OH} | Specified as $V_{DD} - V_{OUT}$, $R_L = 5k\Omega$ | | | | 200 | mV |
| Output Voltage Low | V_{OL} | Specified as $V_{OUT} - V_{SS}$, $R_L = 5k\Omega$ | | | | 50 | mV |

Note 1: Guaranteed by design.

Note 2: Specifications are 100% tested at $T_A = +25^\circ C$ (exceptions noted). All temperature limits are guaranteed by design.

Typical Operating Characteristics

($V_{DD} = +5V$, $V_{SS} = 0V$, $V_{CM} = V_{DD}/2$, $V_{SHDN} = 5V$, $R_L \geq 1M\Omega$ connected to $V_{DD}/2$, $T_A = +25^\circ C$, unless otherwise noted.)

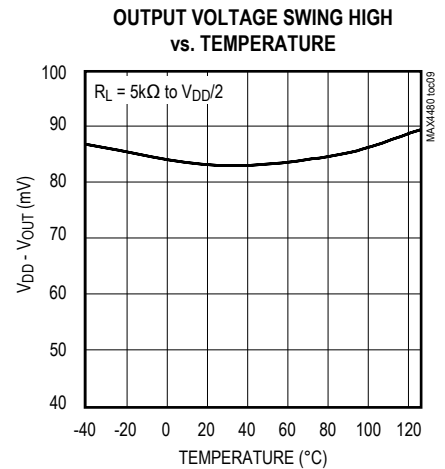
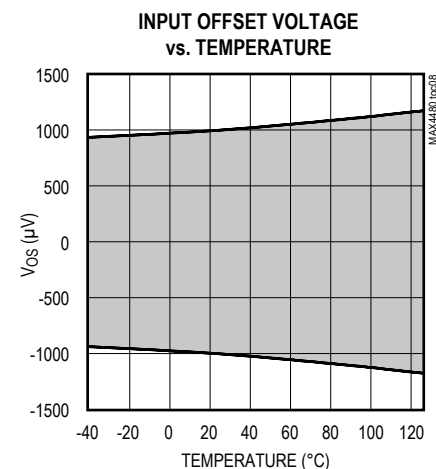
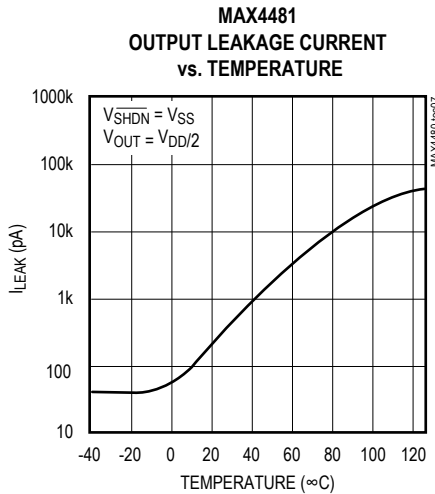
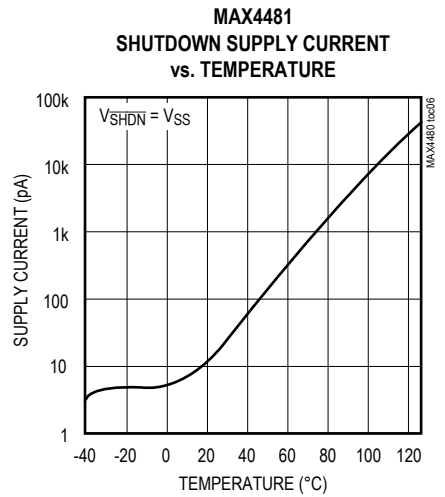
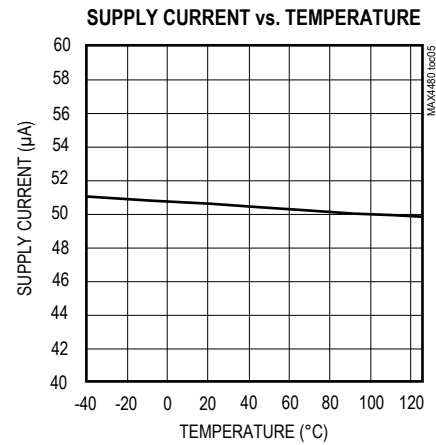
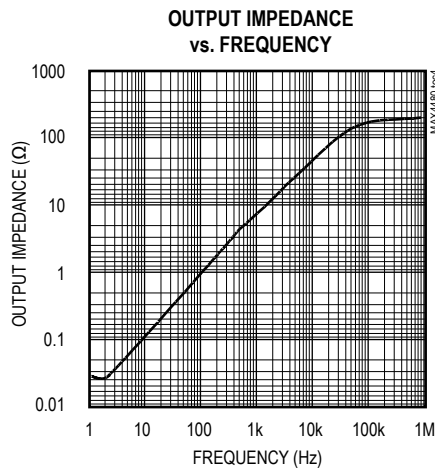
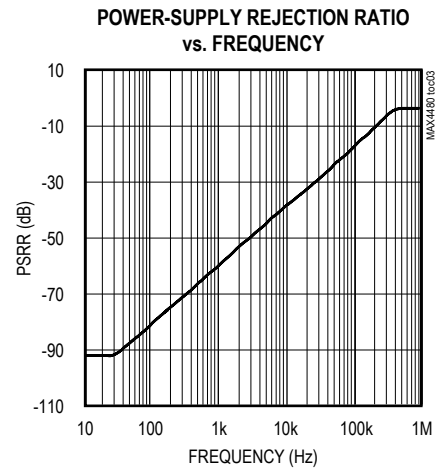
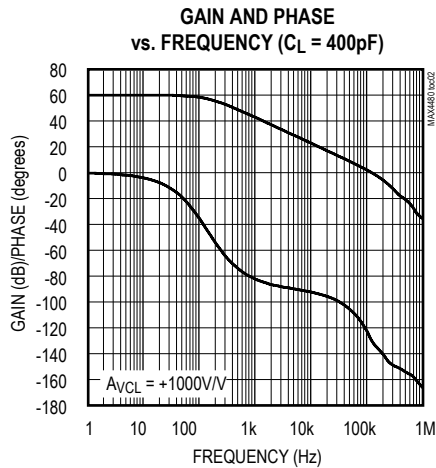
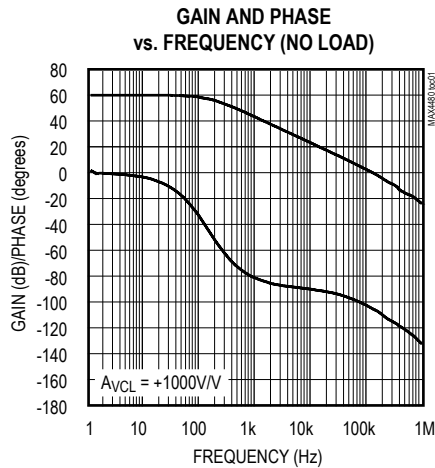

Typical Operating Characteristics (continued)

($V_{DD} = +5V$, $V_{SS} = 0V$, $V_{CM} = V_{DD}/2$, $V_{SHDN} = 5V$, $R_L \geq 1M\Omega$ connected to $V_{DD}/2$, $T_A = +25^\circ C$, unless otherwise noted.)

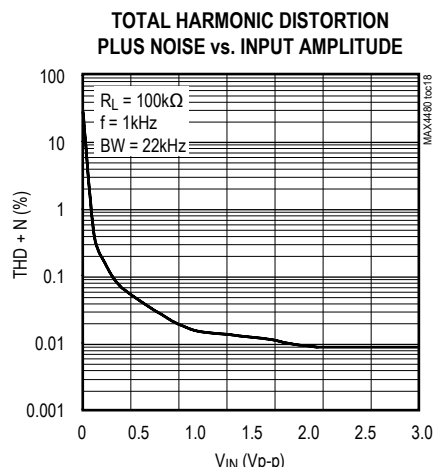
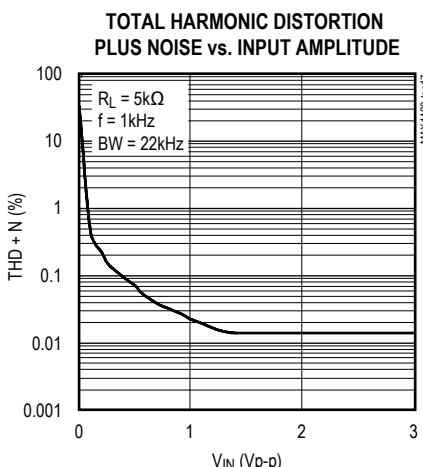
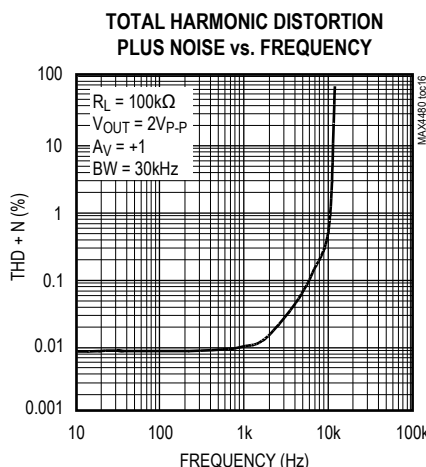
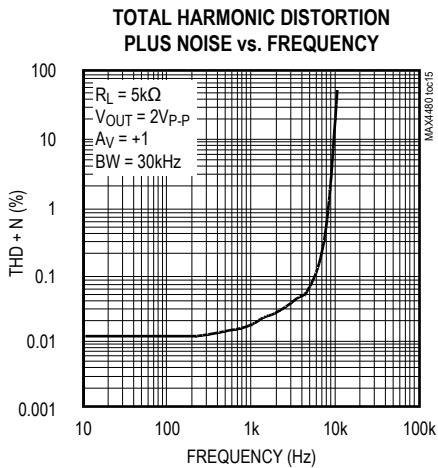
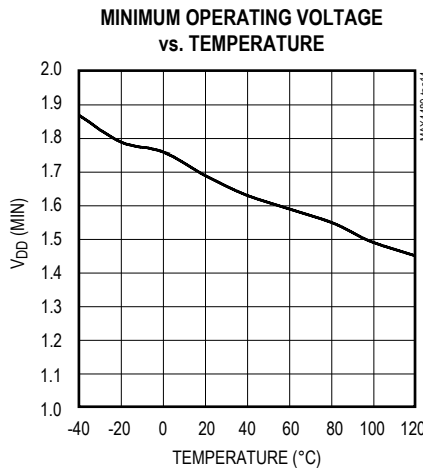
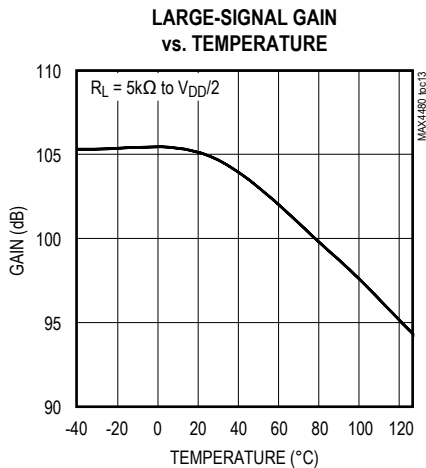
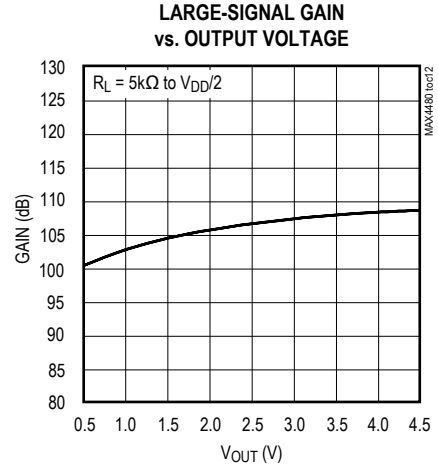
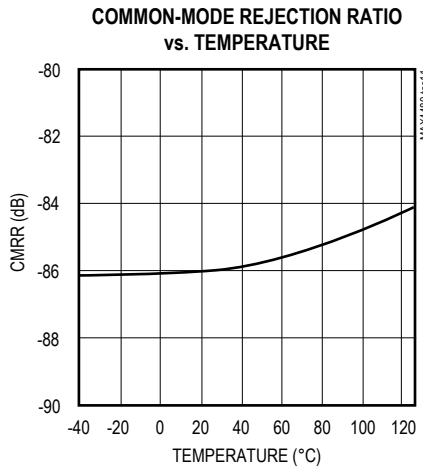
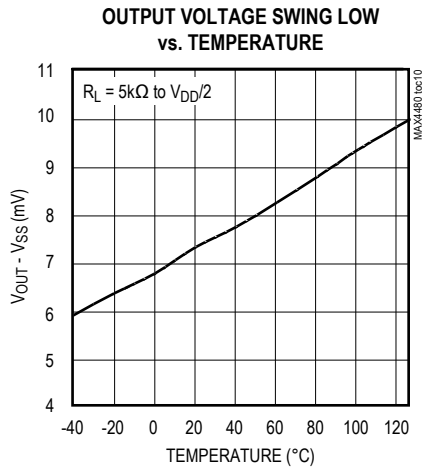

Typical Operating Characteristics (continued)

($V_{DD} = +5V$, $V_{SS} = 0V$, $V_{CM} = V_{DD}/2$, $V_{SHDN} = 5V$, $R_L \geq 1M\Omega$ connected to $V_{DD}/2$, $T_A = +25^\circ C$, unless otherwise noted.)

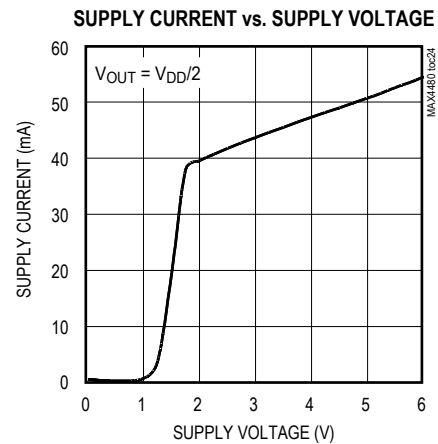
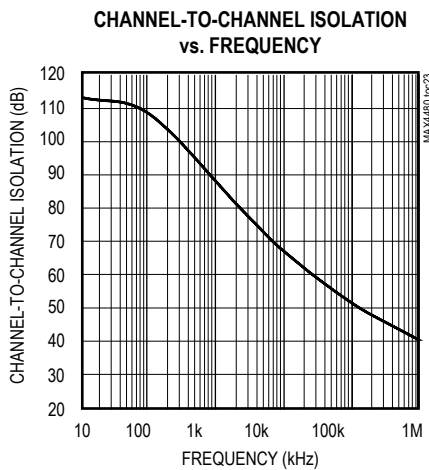
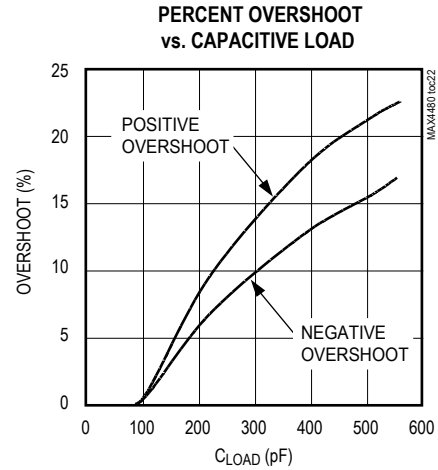
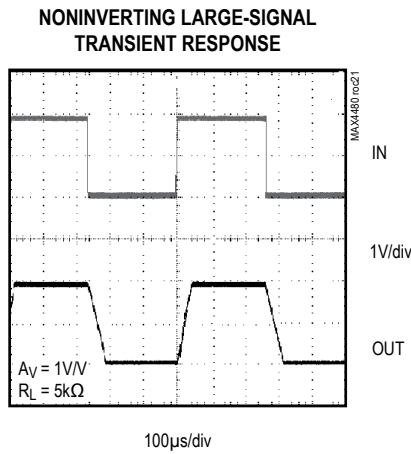
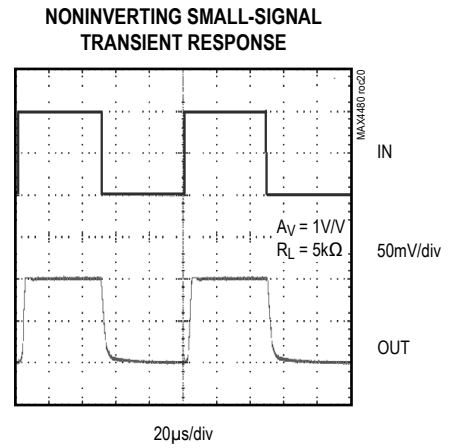
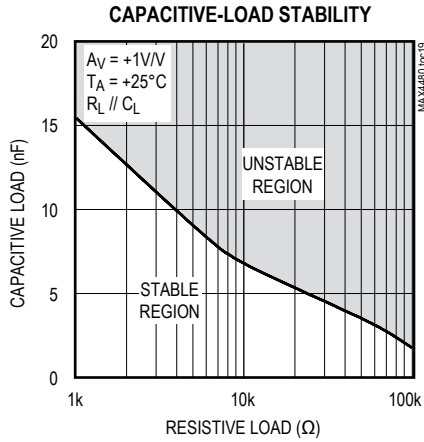

Pin Description

| PIN | | | | NAME | FUNCTION |
|---------|---------|---------|---------|--------------------------|---|
| MAX4480 | MAX4481 | MAX4482 | MAX4483 | | |
| 1 | 1 | — | — | IN+ | Noninverting Amplifier Input |
| — | — | 3 | 3 | INA+ | Noninverting Amplifier Input A |
| — | — | 5 | 5 | INB+ | Noninverting Amplifier Input B |
| — | — | — | 10 | INC+ | Noninverting Amplifier Input C |
| — | — | — | 12 | IND+ | Noninverting Amplifier Input D |
| 2 | 2 | 4 | 11 | V _{SS} | Negative Supply. Connect to ground for single-supply operation. Use a 0.01μF bypass capacitor to GND. |
| 3 | 3 | — | — | IN- | Inverting Amplifier Input |
| — | — | 2 | 2 | INA- | Inverting Amplifier Input A |
| — | — | 6 | 6 | INB- | Inverting Amplifier Input B |
| — | — | — | 9 | INC- | Inverting Amplifier Input C |
| — | — | — | 13 | IND- | Inverting Amplifier Input D |
| 4 | 4 | — | — | OUT | Amplifier Output |
| — | — | 1 | 1 | OUTA | Amplifier Output A |
| — | — | 7 | 7 | OUTB | Amplifier Output B |
| — | — | — | 8 | OUTC | Amplifier Output C |
| — | — | — | 14 | OUTD | Amplifier Output D |
| 5 | 6 | 8 | 4 | V _{DD} | Positive Supply. Use a 0.01μF bypass capacitor to GND. |
| — | 5 | — | — | $\overline{\text{SHDN}}$ | Active-Low Shutdown Input. Connect to V _{DD} for normal operation. Do not leave floating. |

Detailed Description

Rail-to-Rail Output Stage

The MAX4480–MAX4483 can drive a 5kΩ load and still typically swing within 80mV of the supply rails. Figure 1 shows the MAX4480 output voltage swing configured with $A_V = +10V/V$.

Driving Capacitive Loads

Driving a capacitive load can cause instability in many op amps, especially those with low quiescent current. The MAX4480–MAX4483 are unity-gain stable for a range of capacitive loads to above 400pF. Figure 2 shows the MAX4480 response with an excessive capacitive load. Adding a series resistor between the output and the load capacitor (Figure 3) improves the circuit's response by isolating the load capacitance from the op amp's output.

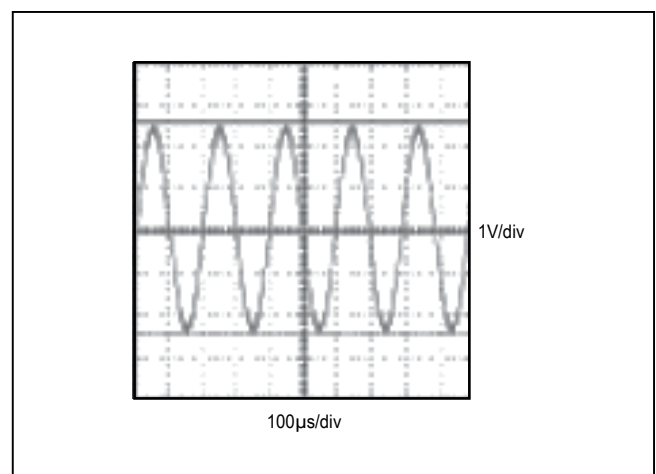

Figure 1. Rail-to-Rail Output Operation

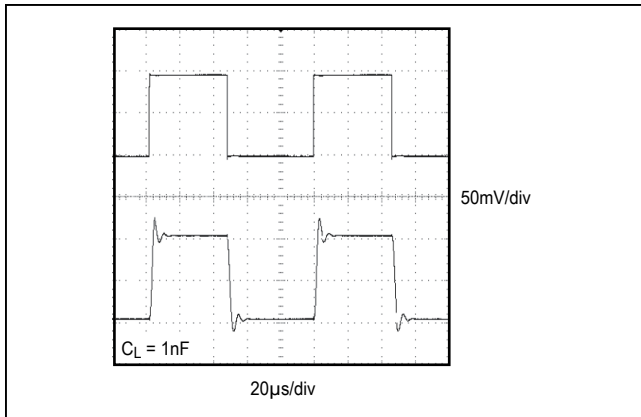

Figure 2. Small-Signal Transient Response with Excessive Capacitive Load

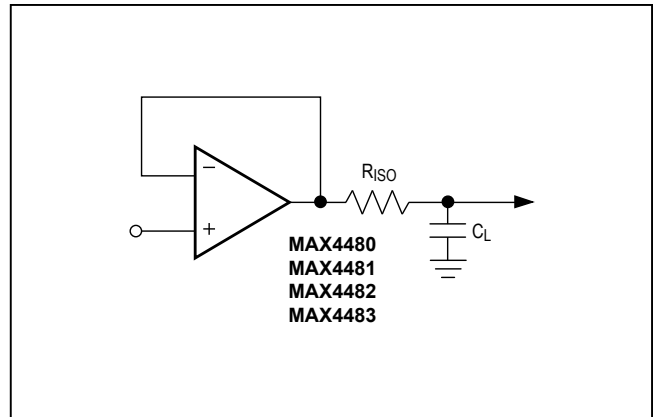

Figure 3. Capacitive-Load-Driving Circuit

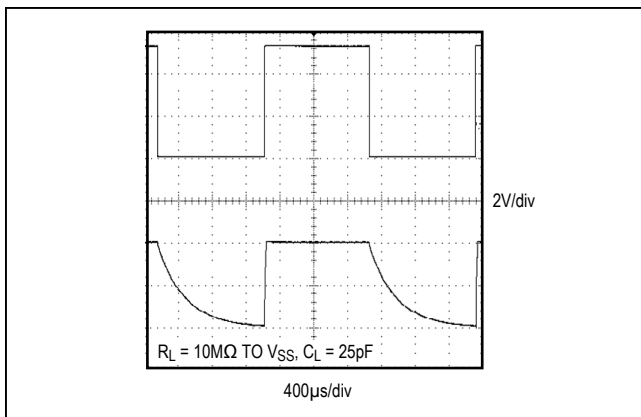

Figure 4. Shutdown Waveform

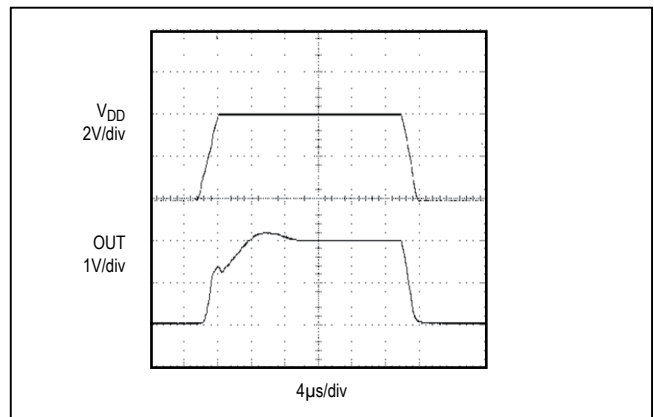

Figure 5. Power-Up/Down Waveform

Applications Information

Shutdown Mode

The MAX4481 features a low-power shutdown mode. When $\overline{\text{SHDN}}$ goes low, the supply current drops to 0.05µA (typ) and the output enters a high-impedance state. Pull $\overline{\text{SHDN}}$ high to enable the amplifier. Do not leave $\overline{\text{SHDN}}$ floating. Figure 4 shows the shutdown waveform.

Power-Up

The MAX4480–MAX4483 outputs typically settle within 50µs after power-up. Figure 5 shows the output voltage on power-up and power-down.

Power Supplies and Layout

The MAX4480–MAX4483 operate from a single +2.5V to +5.5V power supply. Bypass the power supply with a 0.1µF capacitor to ground.

Good layout techniques optimize performance by decreasing the amount of stray capacitance at the op amp’s inputs and outputs. To decrease stray capacitance, minimize trace lengths by placing external components close to the op amp’s pins.

Chip Information

PROCESS: BiCMOS

Pin Configurations (continued)

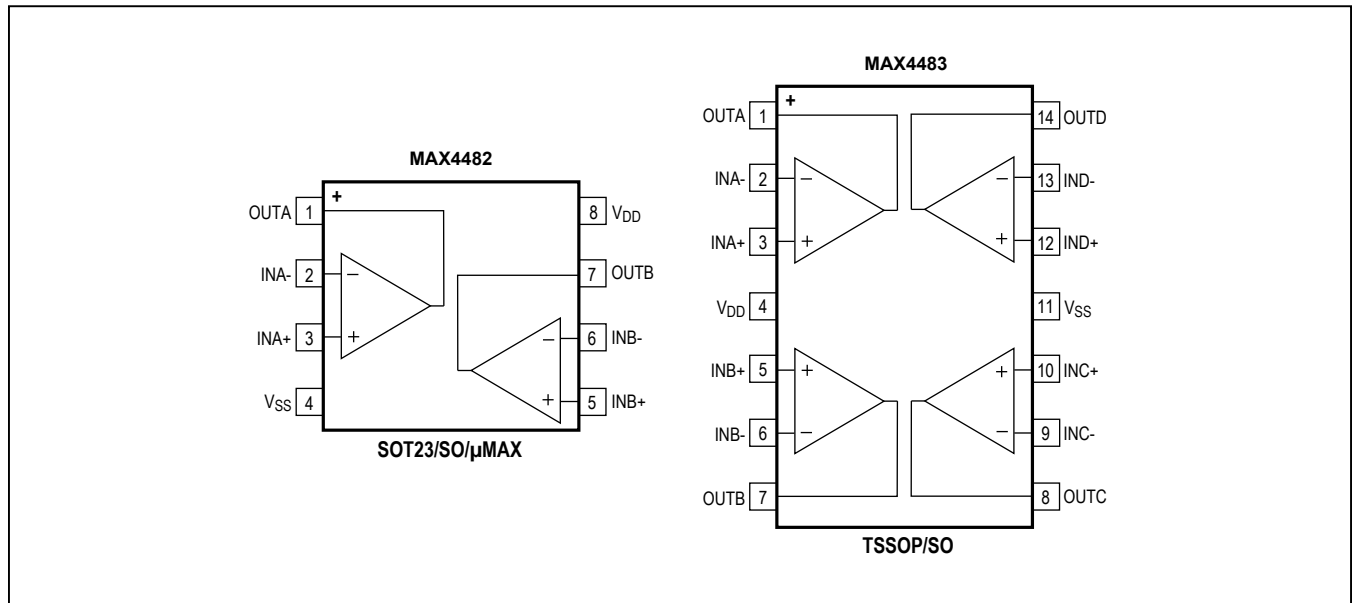

Package Information

For the latest package outline information and land patterns (footprints), go to www.maximintegrated.com/packages. Note that a “+”, “#”, or “-” in the package code indicates RoHS status only. Package drawings may show a different suffix character, but the drawing pertains to the package regardless of RoHS status.

| PACKAGE TYPE | PACKAGE CODE | OUTLINE NO. | LAND PATTERN NO. |
|--------------|--------------|-------------------------|-------------------------|
| 5 SC70 | X5+1 | 21-0076 | 90-0188 |
| 5 SOT23 | U5+1 | 21-0057 | 90-0174 |
| 6 SC70 | X6SN+1 | 21-0077 | 90-0189 |
| 6 SOT23 | U6SN+1 | 21-0058 | 90-0175 |
| 8 SOT23 | K8+5 | 21-0078 | 90-0176 |
| 8 SO | S8+2 | 21-0041 | 90-0096 |
| 8 μMAX | U8+1 | 21-0036 | 90-0092 |
| 14 TSSOP | U14+1 | 21-0066 | 90-0113 |
| 14 SO | S14+1 | 21-0041 | 90-0112 |

Revision History

| REVISION NUMBER | REVISION DATE | DESCRIPTION | PAGES CHANGED |
|-----------------|---------------|--|---------------|
| 0 | 10/00 | Initial release | — |
| 1 | 1/01 | Released MAX4481, revised <i>Electrical Characteristics</i> and Figures 2 and 4. | 1, 2, 3, 8 |
| 2 | 10/12 | Added MAX4481MXT/PR2-W and lead-free notation to <i>Ordering Information</i> . Revised <i>Absolute Maximum Ratings</i> with military temp range. | 1, 2 |
| 3 | 4/13 | Removed –W from MAX4481MXT/PR2 in <i>Ordering Information</i> and revised <i>Absolute Maximum Ratings</i> and updated to MAX4481MXT/PR3+. | 1, 2 |
| 4 | 5/14 | Removed automotive reference from <i>General Description</i> | 1 |

For pricing, delivery, and ordering information, please contact Maxim Direct at 1-888-629-4642, or visit Maxim Integrated's website at www.maximintegrated.com.

Maxim Integrated cannot assume responsibility for use of any circuitry other than circuitry entirely embodied in a Maxim Integrated product. No circuit patent licenses are implied. Maxim Integrated reserves the right to change the circuitry and specifications without notice at any time. The parametric values (min and max limits) shown in the *Electrical Characteristics* table are guaranteed. Other parametric values quoted in this data sheet are provided for guidance.

Looking for pricing, stock, or lifecycle information?

Click below to explore more details on WIN SOURCE:

- ⊖ [View MAX4481AUT+T on WIN SOURCE](#)
- ⊖ [Maxim Integrated Information](#)

Optimize Your Supply Chain with WIN SOURCE Solutions

- ✓ Global Sourcing Solution
- ✓ Obsolete Management
- ✓ Cost Control Management
- ✓ Shortage Management
- ✓ Alternative Solution
- ✓ Excess Inventory Management