



**THE DATASHEET OF
MAX3679CTJ+T**



EVALUATION KIT
AVAILABLE

+3.3V, Low-Jitter Crystal to LVPECL Clock Generator

MAX3679

General Description

The MAX3679 is a low-jitter precision clock generator with the integration of three LVPECL and one LVCMOS outputs optimized for Ethernet applications. The device integrates a crystal oscillator and a phase-locked loop (PLL) clock multiplier to generate high-frequency clock outputs for Ethernet applications.

Maxim's proprietary PLL design features ultra-low jitter (0.36psRMS) and excellent power-supply noise rejection, minimizing design risk for network equipment.

Applications

Ethernet Networking Equipment

Features

- ◆ Crystal Oscillator Interface: 25MHz
- ◆ CMOS Input: 25MHz
- ◆ Output Frequencies for Ethernet
62.5MHz, 125MHz, 156.25MHz, 312.5MHz
- ◆ Low Jitter
0.14psRMS (1.875MHz to 20MHz)
0.36psRMS (12kHz to 20MHz)
- ◆ Excellent Power-Supply Noise Rejection
- ◆ No External Loop Filter Capacitor Required

Ordering Information

PART	TEMP RANGE	PIN-PACKAGE
MAX3679CTJ+	0°C to +70°C	32 TQFN-EP*

+ Denotes a lead-free/RoHS-compliant package.

*EP = Exposed pad.

Pin Configuration appears at end of data sheet.

Typical Application Circuit

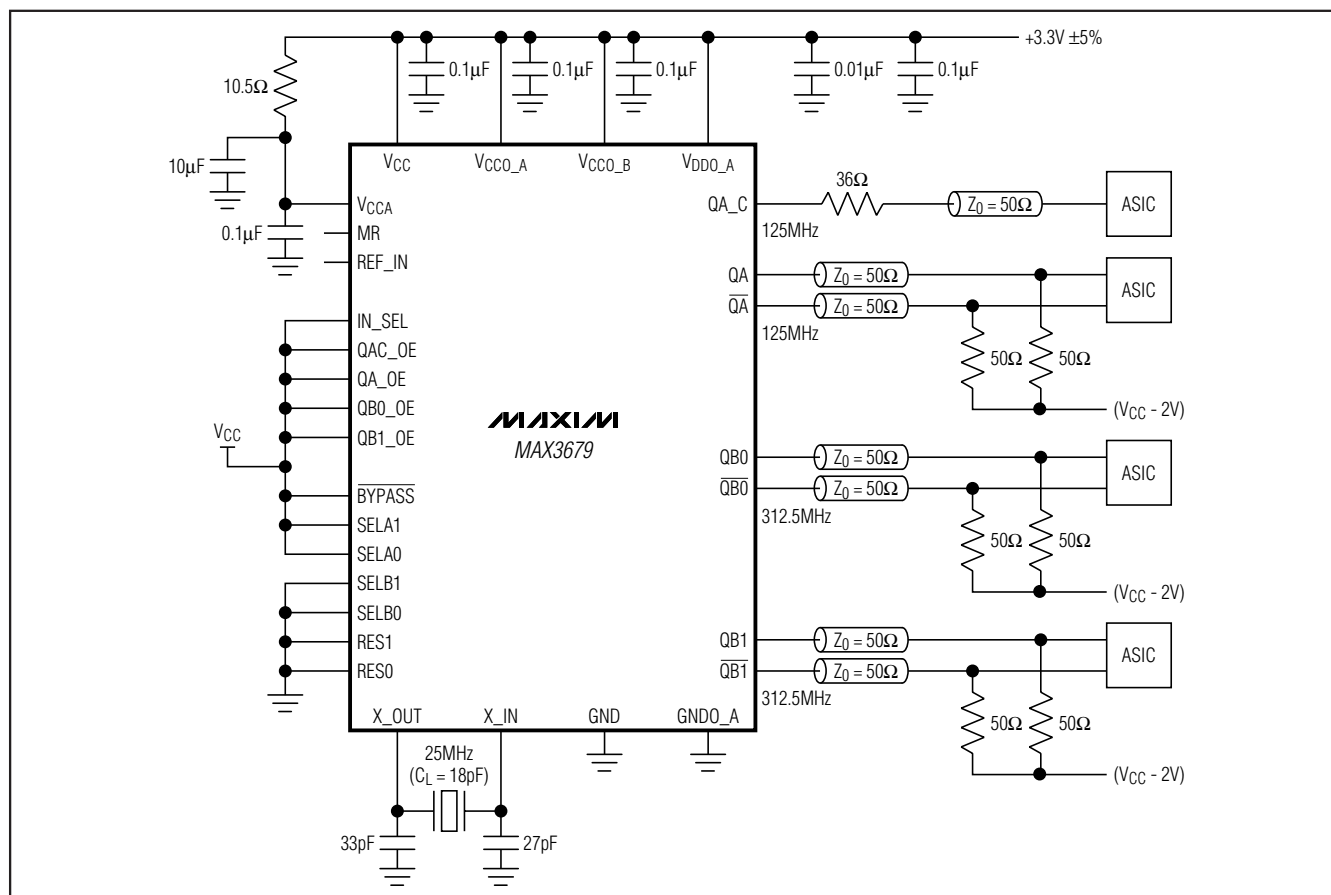

+3.3V, Low-Jitter Crystal to LVPECL Clock Generator

ABSOLUTE MAXIMUM RATINGS

Supply Voltage Range V_{CC} , V_{CCA} ,
 V_{DDO_A} , V_{CCO_A} , V_{CCO_B} -0.3V to +4.0V
 Voltage Range at REF_IN, IN_SEL,
 SELA[1:0], SELB[1:0], RES[1:0],
 QAC_OE, QA_OE, QB0_OE, QB1_OE,
 MR, $\overline{\text{BYPASS}}$ -0.3V to ($V_{CC} + 0.3\text{V}$)
 Voltage Range at X_IN Pin-0.3V to +1.2V

Voltage Range at GNDO_A.....-0.3V to +0.3V
 Voltage Range at X_OUT-0.3V to ($V_{CC} - 0.6\text{V}$)
 Current into QA_C $\pm 50\text{mA}$
 Current into QA, $\overline{\text{QA}}$, QB0, $\overline{\text{QB0}}$, QB1, $\overline{\text{QB1}}$ -56mA
 Continuous Power Dissipation ($T_A = +70^\circ\text{C}$)
 32-Pin TQFN (derate 34.5mW/ $^\circ\text{C}$ above +70 $^\circ\text{C}$)2759mW
 Operating Junction Temperature Range.....-55 $^\circ\text{C}$ to +150 $^\circ\text{C}$
 Storage Temperature Range-65 $^\circ\text{C}$ to +160 $^\circ\text{C}$

Stresses beyond those listed under "Absolute Maximum Ratings" may cause permanent damage to the device. These are stress ratings only, and functional operation of the device at these or any other conditions beyond those indicated in the operational sections of the specifications is not implied. Exposure to absolute maximum rating conditions for extended periods may affect device reliability.

ELECTRICAL CHARACTERISTICS

($V_{CC} = +3.0\text{V}$ to +3.6V, $T_A = 0^\circ\text{C}$ to +70 $^\circ\text{C}$, unless otherwise noted. Typical values are at $V_{CC} = +3.3\text{V}$, $T_A = +25^\circ\text{C}$, unless otherwise noted.) (Notes 1, 2, and 3)

PARAMETER	SYMBOL	CONDITIONS	MIN	TYP	MAX	UNITS
Power-Supply Current	I_{CC}	(Note 4)		77	100	mA
CONTROL INPUT CHARACTERISTICS (SELA[1:0], SELB[1:0], IN_SEL, QAC_OE, QA_OE, QB1_OE, QB0_OE, MR, $\overline{\text{BYPASS}}$ Pins)						
Input Capacitance	C_{IN}			2		pF
Input Pulldown Resistor	$R_{PULLDOWN}$	Pin MR		75		k Ω
Input Logic Bias Resistor	R_{BIAS}	Pins SELA[1:0], SELB[1:0], QB0_OE		50		k Ω
Input Pullup Resistor	R_{PULLUP}	Pins QAC_OE, QA_OE, QB1_OE, IN_SEL, $\overline{\text{BYPASS}}$		75		k Ω
LVPECL OUTPUT SPECIFICATIONS (QA, $\overline{\text{QA}}$, QB0, $\overline{\text{QB0}}$, QB1, $\overline{\text{QB1}}$ Pins)						
Output High Voltage	V_{OH}		$V_{CC} - 1.13$	$V_{CC} - 0.98$	$V_{CC} - 0.83$	V
Output Low Voltage	V_{OL}		$V_{CC} - 1.85$	$V_{CC} - 1.7$	$V_{CC} - 1.55$	V
Peak-to-Peak Output-Voltage Swing (Single-Ended)		(Note 2)	0.6	0.72	0.9	V_{P-P}
Clock Output Rise/Fall Time		20% to 80% (Note 2)	200	350	600	ps
Output Duty-Cycle Distortion		PLL enabled	48	50	52	%
		PLL bypassed (Note 5)	40	50	60	
LVC MOS/LVTTL INPUT SPECIFICATIONS (SELA[1:0], SELB[1:0], IN_SEL, QAC_OE, QA_OE, QB1_OE, QB0_OE, MR, $\overline{\text{BYPASS}}$ Pins)						
Input-Voltage High	V_{IH}		2.0			V
Input-Voltage Low	V_{IL}				0.8	V
Input High Current	I_{IH}	$V_{IN} = V_{CC}$			80	μA
Input Low Current	I_{IL}	$V_{IN} = 0\text{V}$	-80			μA

+3.3V, Low-Jitter Crystal to LVPECL Clock Generator

MAX3679

ELECTRICAL CHARACTERISTICS (continued)

($V_{CC} = +3.0V$ to $+3.6V$, $T_A = 0^\circ C$ to $+70^\circ C$, unless otherwise noted. Typical values are at $V_{CC} = +3.3V$, $T_A = +25^\circ C$, unless otherwise noted.) (Notes 1, 2, and 3)

PARAMETER	SYMBOL	CONDITIONS	MIN	TYP	MAX	UNITS	
REF_IN SPECIFICATIONS (Input DC- or AC-Coupled)							
Reference Clock Frequency		PLL enabled	25			MHz	
		PLL bypassed	320				
Input-Voltage High	V_{IH}		2.0			V	
Input-Voltage Low	V_{IL}		0.8			V	
Input High Current	I_{IH}	$V_{IN} = V_{CC}$	240			μA	
Input Low Current	I_{IL}	$V_{IN} = 0V$	-240			μA	
Reference Clock Duty Cycle		PLL enabled	30			70	%
Input Capacitance			2.5			pF	
QA_C SPECIFICATIONS							
Output High Voltage	V_{OH}	QA_C sourcing 12mA	2.6			V	
Output Low Voltage	V_{OL}	QA_C sinking 12mA	0.4			V	
Output Rise/Fall Time		(Notes 3 and 6)	250	500	1000	ps	
Output Duty-Cycle Distortion		PLL enabled	42	50	58	%	
		PLL bypassed (Note 5)	40		60		
Output Impedance			14			Ω	
CLOCK OUTPUT AC SPECIFICATIONS							
VCO Frequency Range			625			MHz	
Random Jitter (Note 7)	RJ_{RMS}	12kHz to 20MHz	0.36			psRMS	
		1.875MHz to 20MHz	0.14				
Deterministic Jitter Due to Supply Noise (Notes 7, 8, 9)		LVPECL output	5.0			psP-P	
Spurs Induced by Power-Supply Noise (Notes 7, 9, 10)		LVPECL output	-59			dBc	
		LVC MOS output	-47				
Nonharmonic and Subharmonic Spurs			-70			dBc	
Output Skew		Between QB0 and QB1	15			ps	
		Between QA and QB0 or QB1, PECL outputs	20				

+3.3V, Low-Jitter Crystal to LVPECL Clock Generator

ELECTRICAL CHARACTERISTICS (continued)

($V_{CC} = +3.0V$ to $+3.6V$, $T_A = 0^\circ C$ to $+70^\circ C$, unless otherwise noted. Typical values are at $V_{CC} = +3.3V$, $T_A = +25^\circ C$ unless otherwise noted.) (Notes 1, 2, and 3)

PARAMETER	SYMBOL	CONDITIONS	MIN	TYP	MAX	UNITS
Clock Output SSB Phase Noise at 125MHz (Note 11)		f = 1kHz		-124		dBc/Hz
		f = 10kHz		-125		
		f = 100kHz		-130		
		f = 1MHz		-145		
		f > 10MHz		-153		

Note 1: A series resistor of up to 10.5Ω is allowed between V_{CC} and V_{CCA} for filtering supply noise when system power-supply tolerance is $V_{CC} = 3.3V \pm 5\%$. See Figure 2.

Note 2: Guaranteed up to 320MHz for LVPECL output.

Note 3: Guaranteed up to 160MHz for LVCMOS output.

Note 4: All outputs enabled and unloaded. IN_SEL set high.

Note 5: Measured with crystal or AC-coupled, 50% duty-cycle signal on REF_IN.

Note 6: Measured using setup shown in Figure 1 with $V_{CC} = 3.3V \pm 5\%$.

Note 7: Measured with crystal source.

Note 8: Total TIE including random and deterministic jitter. Measured with Agilent DSO81304A 40GS/s real-time oscilloscope using 2M sample record length.

Note 9: Measured with $40mV_{P-P}$, 100kHz sinusoidal signal on the supply.

Note 10: Measured at 156.25MHz output.

Note 11: Measured with 25MHz crystal or 25MHz reference clock at LVCMOS input with a slew rate of 0.5V/ns or greater.

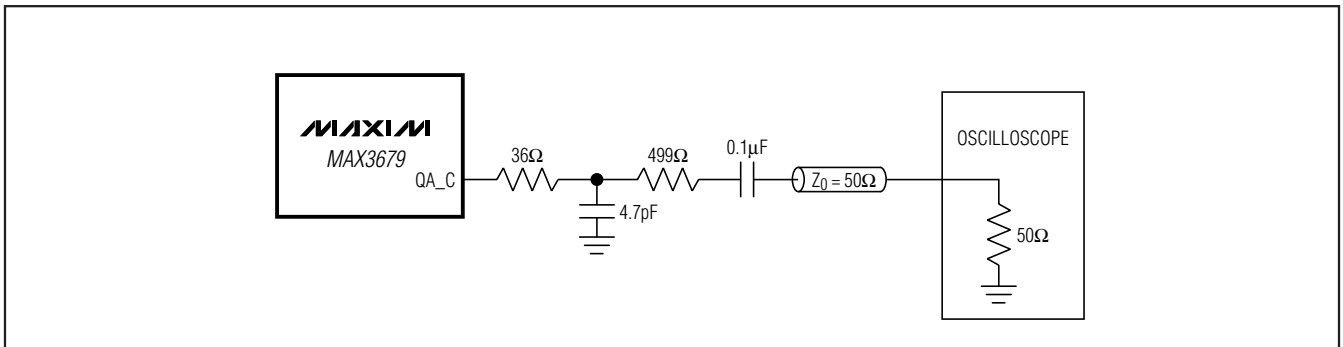

Figure 1. LVCMOS Output Measurement Setup

+3.3V, Low-Jitter Crystal to LVPECL Clock Generator

Typical Operating Characteristics

(Typical values are at $V_{CC} = +3.3V$, $T_A = +25^\circ C$, crystal frequency = 25MHz.)

MAX3679

SUPPLY CURRENT vs. TEMPERATURE

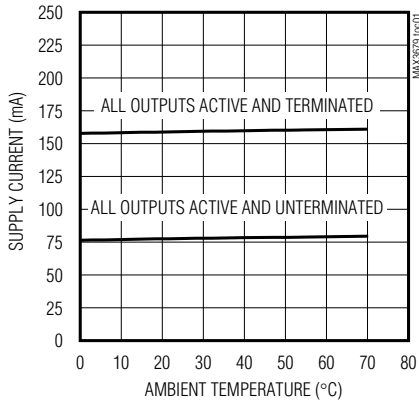

DIFFERENTIAL OUTPUT WAVEFORM AT 156.25MHz (LVPECL OUTPUT)

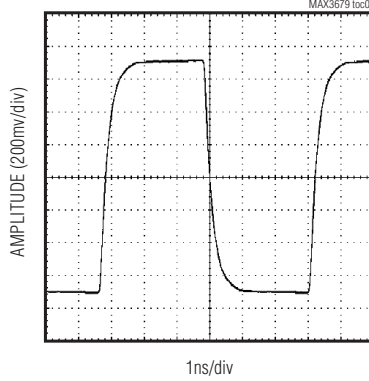

OUTPUT WAVEFORM AT 125MHz (LVCMOS OUTPUT)

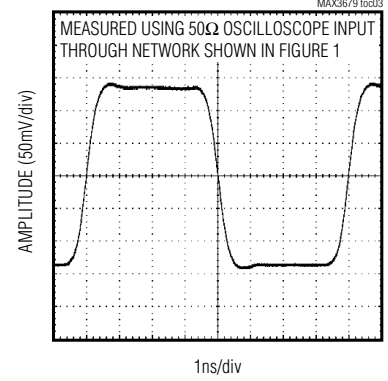

PHASE NOISE AT 312.5MHz CLOCK FREQUENCY

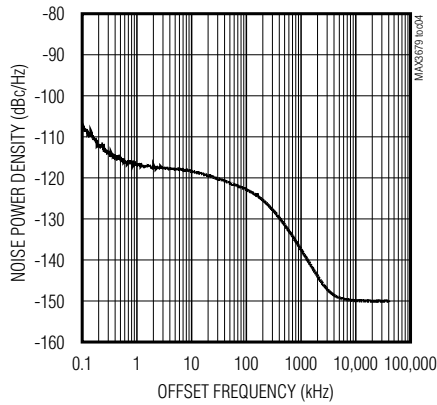

PHASE NOISE AT 125MHz CLOCK FREQUENCY

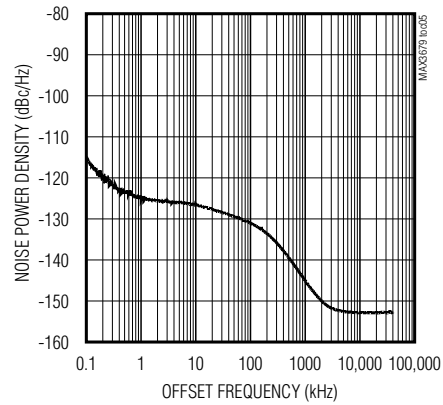

JITTER HISTOGRAM (312.5MHz OUTPUT, 40mVp-p SUPPLY NOISE AT 100kHz)

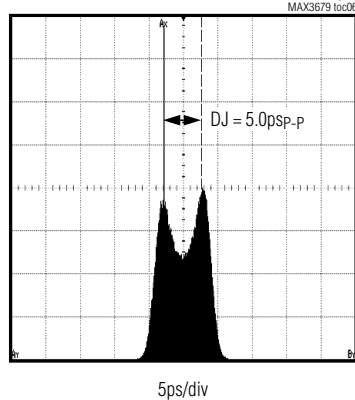

NOISE SPUR AMPLITUDE vs. NOISE FREQUENCY

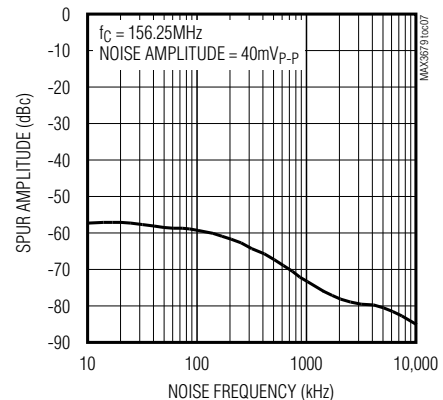

+3.3V, Low-Jitter Crystal to LVPECL Clock Generator

Pin Description

PIN	NAME	FUNCTION
1	VCCO_B	Power Supply for QB0 and QB1 Clock Outputs. Connect to +3.3V.
2, 19, 24	GND	Supply Ground
3	QB0_OE	LVC MOS/LVTTL Input. Enables/disables QB0 clock output. Connect pin high to enable LVPECL clock output QB0. Connect low to set QB0 to a logic 0. Has internal 50k Ω input impedance.
4, 5	SELB1, SELB0	LVC MOS/LVTTL Input. Controls NB divider setting. Has 50k Ω input impedance. See Table 2 for more information.
6	QAC_OE	LVC MOS/LVTTL Input. Enables/disables QA_C clock output. Connect pin high to enable QA_C. Connect low to set QA_C to a high-impedance state. Has internal 75k Ω pullup to VCC.
7	MR	LVC MOS/LVTTL Input. Master reset input. Pulse high for > 1 μ s to reset all dividers. Has internal 75k Ω pulldown to GND. Not required for normal operation.
8	GND0_A	Ground for QA_C Output. Connect to supply ground.
9	QA_C	LVC MOS Clock Output
10	VDDO_A	Power Supply for QA_C Clock Output. Connect to +3.3V.
11	VCCO_A	Power Supply for QA Clock Output. Connect to +3.3V.
12	QA	Noninverting Clock Output, LVPECL
13	\overline{QA}	Inverting Clock Output, LVPECL
14	\overline{BYPASS}	LVC MOS/LVTTL Input (Active Low). Connect low to bypass the internal PLL. Connect high for normal operation. When in bypass mode the output dividers are set to divide by 1. Has internal 75k Ω pullup to VCC.
15	RES1	Not Internally Connected. Connect to GND, VCC, or leave open for normal operation.
16	RES0	Reserved for Test. Connect to GND for normal operation.
17	VCCA	Analog Power Supply for the VCO. Connect to +3.3V. For additional power-supply noise filtering, this pin can connect to VCC through 10.5 Ω as shown in Figure 2 (requires VCC = +3.3V \pm 5%).
18	VCC	Core Power Supply. Connect to +3.3V.
20	QA_OE	LVC MOS/LVTTL Input. Enables/disables the QA clock output. Connect this pin high to enable the LVPECL clock output QA. Connect low to set QA to a logic 0. Has internal 75k Ω pullup to VCC.
21, 22	SELA0, SELA1	LVC MOS/LVTTL Input. Controls NA divider setting. See Table 2 for more information. Has 50k Ω input impedance.
23	QB1_OE	LVC MOS/LVTTL Input. Enables/disables QB1 clock output. Connect pin high to enable LVPECL clock output QB1. Connect low to set QB1 to a logic 0. Has internal 50k Ω input impedance.
25	X_OUT	Crystal Oscillator Output
26	X_IN	Crystal Oscillator Input
27	REF_IN	LVC MOS Reference Clock Input. Self-biased to allow AC- or DC-coupling.
28	IN_SEL	LVC MOS/LVTTL Input. Connect high or leave open to use a crystal. Connect low to use REF_IN. Has internal 75k Ω pullup to VCC.
29	$\overline{QB1}$	LVPECL, Inverting Clock Output
30	QB1	LVPECL, Noninverting Clock Output
31	$\overline{QB0}$	LVPECL, Inverting Clock Output
32	QB0	LVPECL, Noninverting Clock Output
—	EP	Exposed Pad. Connect to supply ground for proper electrical and thermal performance.

+3.3V, Low-Jitter Crystal to LVPECL Clock Generator

Detailed Description

The MAX3679 is a low-jitter clock generator designed to operate at Ethernet frequencies. It consists of an on-chip crystal oscillator, PLL, programmable dividers, LVCMOS output buffer, and LVPECL output buffers. Using a low-frequency clock (crystal or CMOS input) as a reference, the internal PLL generates a high-frequency output clock with excellent jitter performance.

Crystal Oscillator

An integrated oscillator provides the low-frequency reference clock for the PLL. This oscillator requires an external crystal connected between X_IN and X_OUT. Crystal frequency is 25MHz.

REF_IN Buffer

An LVCMOS-compatible clock source can be connected to REF_IN to serve as the reference clock.

The LVCMOS REF_IN buffer is internally biased to allow AC- or DC-coupling. It is designed to operate up to 320MHz.

PLL

The PLL takes the signal from the crystal oscillator or reference clock input and synthesizes a low-jitter, high-frequency clock. The PLL contains a phase-frequency detector (PFD), a lowpass filter, and a 625MHz voltage-controlled oscillator (VCO). The VCO output is connected to the PFD input through a feedback divider. See Table 3 for divider values. The PFD compares the reference frequency to the divided-down VCO output ($f_{VCO}/25$) and generates a control signal that keeps the VCO locked to the reference clock. The high-frequency VCO output clock is sent to the output dividers. To minimize noise-induced jitter, the VCO supply (V_{CCA}) is isolated from the core logic and output buffer supplies.

Output Dividers

The output divider is programmable to allow a range of output frequencies. See Table 2 for the divider input settings. The output dividers are automatically set to divide by 1 when the MAX3679 is in bypass mode ($BYPASS = 0$).

LVPECL Drivers

The high-frequency outputs—QA, QB0, and QB1—are differential PECL buffers designed to drive transmission lines terminated with 50Ω to $V_{CC} - 2.0V$. The maximum operating frequency is specified up to 320MHz. Each output can be individually disabled, if not used. The outputs go to a logic 0 when disabled.

LVCMOS Driver

QA_C, the LVCMOS output, is designed to drive a single-ended high-impedance load. The maximum operating frequency is specified up to 160MHz. This output can be disabled by the QAC_OE pin if not used and goes to a high impedance when disabled.

Reset Logic/POR

During power-on, the power-on reset (POR) signal is generated to synchronize all dividers. An external master reset (MR) signal is not required.

Applications Information

Power-Supply Filtering

The MAX3679 is a mixed analog/digital IC. The PLL contains analog circuitry susceptible to random noise. In addition to excellent on-chip power-supply noise rejection, the MAX3679 provides a separate power-supply pin, V_{CCA} , for the VCO circuitry. Figure 2 illustrates the recommended power-supply filter network for V_{CCA} . The purpose of this design technique is to ensure clean input power supply to the VCO circuitry and to improve the overall immunity to power-supply noise. This network requires that the power supply is $+3.3V \pm 5\%$. Decoupling capacitors should be used on all other supply pins for best performance.

Output Divider Configuration

Table 2 shows the input settings required to set the output dividers. Leakage in the OPEN case must be less than $1\mu A$. Note that when the MAX3679 is in bypass mode ($BYPASS$ set low), the output dividers are automatically set to divide by 1.

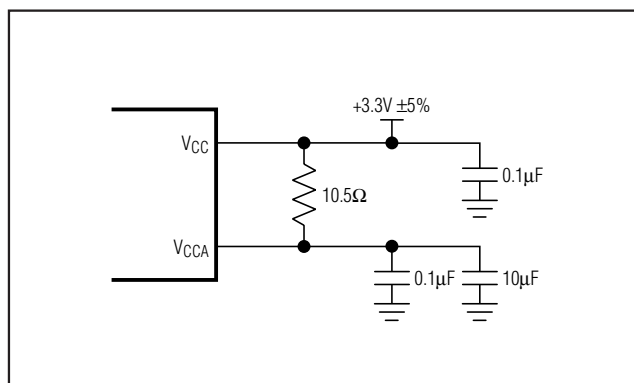

Figure 2. Analog Supply Filtering

+3.3V, Low-Jitter Crystal to LVPECL Clock Generator

Table 1. Output Frequency Determination Chart

XO OR CMOS INPUT FREQUENCY (MHz)	FEEDBACK DIVIDER, M	VCO FREQUENCY (MHz)	OUTPUT DIVIDER, NA AND NB	OUTPUT FREQUENCY (MHz)	APPLICATIONS
25	25	625	÷2	312.5	Ethernet
			÷4	156.25	
			÷5	125	
			÷10	62.5	

Table 2. Output Divider Configuration Chart

INPUT		NA/NB DIVIDER
SELA1/SELB1	SELA0/SELB0	
0	0	÷2*
1	0	÷4
1	1	÷5
0	OPEN	÷10

*Maximum guaranteed output frequency is 160MHz for CMOS and 320MHz for LVPECL output.

Table 3. Crystal Selection Parameters

PARAMETER	SYMBOL	MIN	TYP	MAX	UNITS
Crystal Oscillation Frequency	f _{OSC}		25		MHz
Shunt Capacitance	C _O		2.0	7.0	pF
Load Capacitance	C _L		18		pF
Equivalent Series Resistance (ESR)	R _S			50	Ω
Maximum Crystal				300	μW

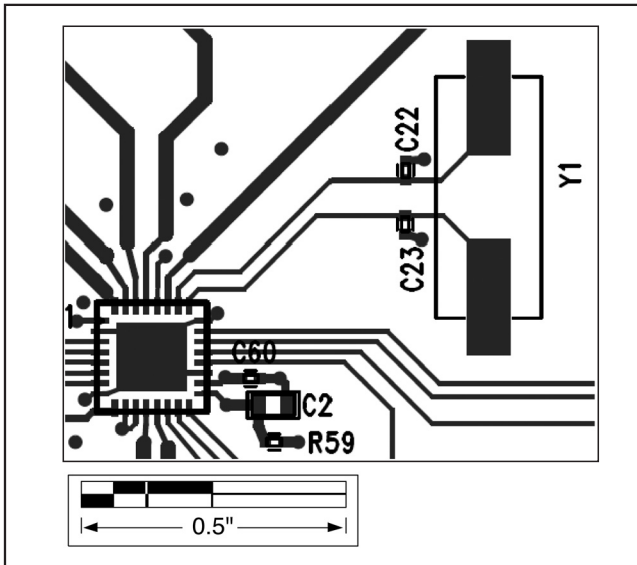

Figure 3. Crystal Layout

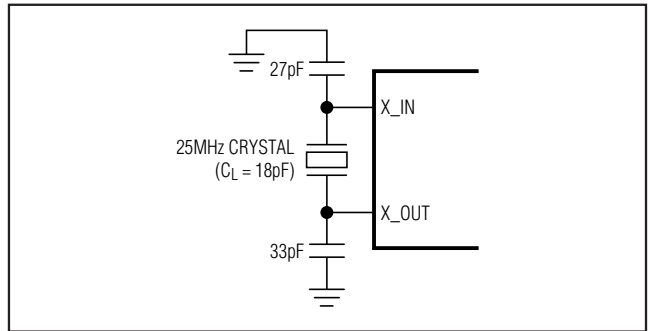

Figure 4. Crystal, Capacitors Connection

Crystal Input Layout and Frequency Stability

The crystal, trace, and two external capacitors should be placed on the board as close as possible to the MAX3679's X_IN and X_OUT pins to reduce crosstalk of active signals into the oscillator.

The layout shown in Figure 3 gives approximately 3pF of trace plus footprint capacitors per side of the crystal (Y1). The dielectric material is FR-4 and dielectric thickness of the reference board is 15 mils. Using a 25MHz crystal and the capacitor values of C22 = 27pF and C23 = 33pF, the measured output frequency accuracy is -14ppm at +25°C ambient temperature.

Crystal Selection

The crystal oscillator is designed to drive a fundamental mode, AT-cut crystal resonator. See Table 3 for recommended crystal specifications. See Figure 4 for external capacitance connection.

+3.3V, Low-Jitter Crystal to LVPECL Clock Generator

Interfacing with LVPECL Outputs

The equivalent LVPECL output circuit is given in Figure 8. These outputs are designed to drive a pair of 50Ω transmission lines terminated with 50Ω to $V_{TT} = V_{CC} - 2V$. If a separate termination voltage (V_{TT}) is not available, other

termination methods can be used such as shown in Figures 5 and 6. Unused outputs should be disabled and can be left open. For more information on LVPECL terminations and how to interface with other logic families, refer to Application Note 291: *HFAN-01.0: Introduction to LVDS, PECL, and CML*.

Interface Models

Figures 7, 8, and 9 show examples of interface models.

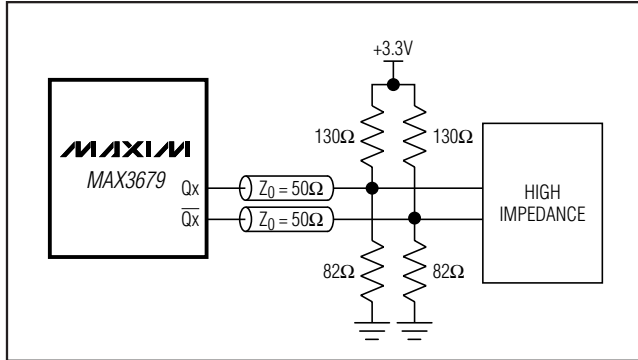

Figure 5. Thevenin Equivalent of Standard PECL Termination

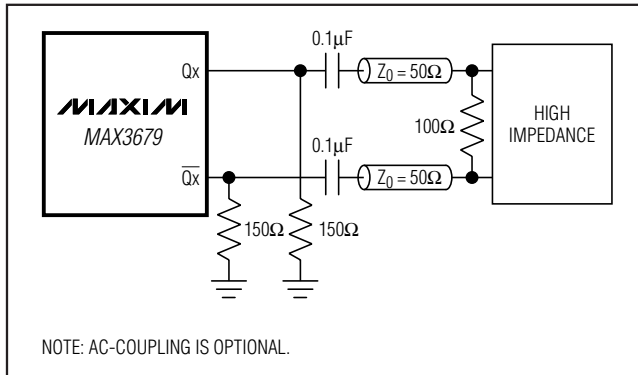

Figure 6. AC-Coupled PECL Termination

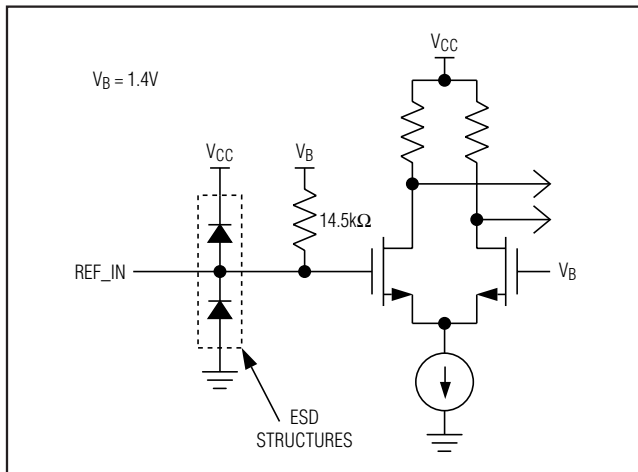

Figure 7. Simplified REF_IN Pin Circuit Schematic

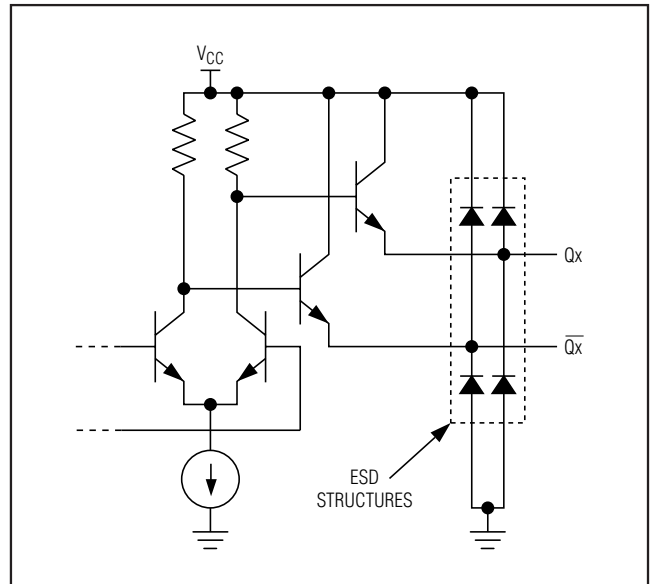

Figure 8. Simplified LVPECL Output Circuit Schematic

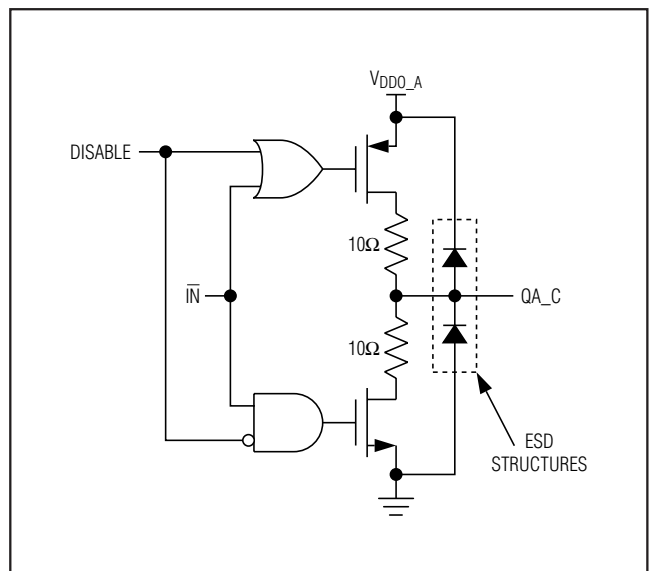

Figure 9. Simplified LVCMOS Output Circuit Schematic

+3.3V, Low-Jitter Crystal to LVPECL Clock Generator

Layout Considerations

The inputs and outputs are critical paths for the MAX3679, and care should be taken to minimize discontinuities on these transmission line. Here are some suggestions for maximizing the MAX3679's performance:

- An uninterrupted ground plane should be positioned beneath the clock I/Os.
- Ground pin vias should be placed close to the IC and the input/output interfaces to allow a return current path to the MAX3679 and the receive devices.
- Supply decoupling capacitors should be placed close to the MAX3679 supply pins.
- Maintain 100Ω differential (or 50Ω single-ended) transmission line impedance out of the MAX3679.
- Use good high-frequency layout techniques and a multilayer board with an uninterrupted ground plane to minimize EMI and crosstalk.

Refer to the MAX3679 Evaluation Kit for more information.

Exposed-Pad Package

The exposed pad on the 32-pin TQFN package provides a very low inductance path for return current traveling to the PCB ground plane. The pad is also electrical ground on the MAX3679 and must be soldered to the circuit board ground for proper electrical performance.

Pin Configuration

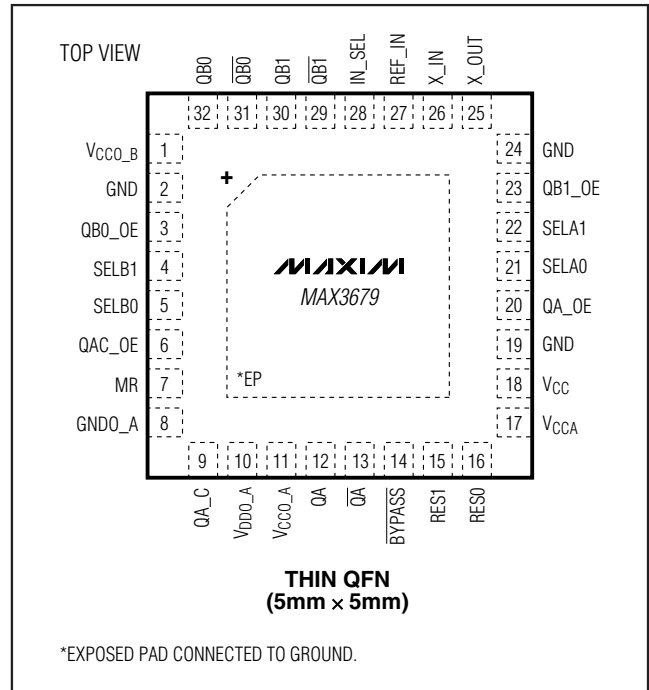

Chip Information

TRANSISTOR COUNT: 10,780

PROCESS: BiCMOS

+3.3V, Low-Jitter Crystal to LVPECL Clock Generator

Block Diagram

MAX3679

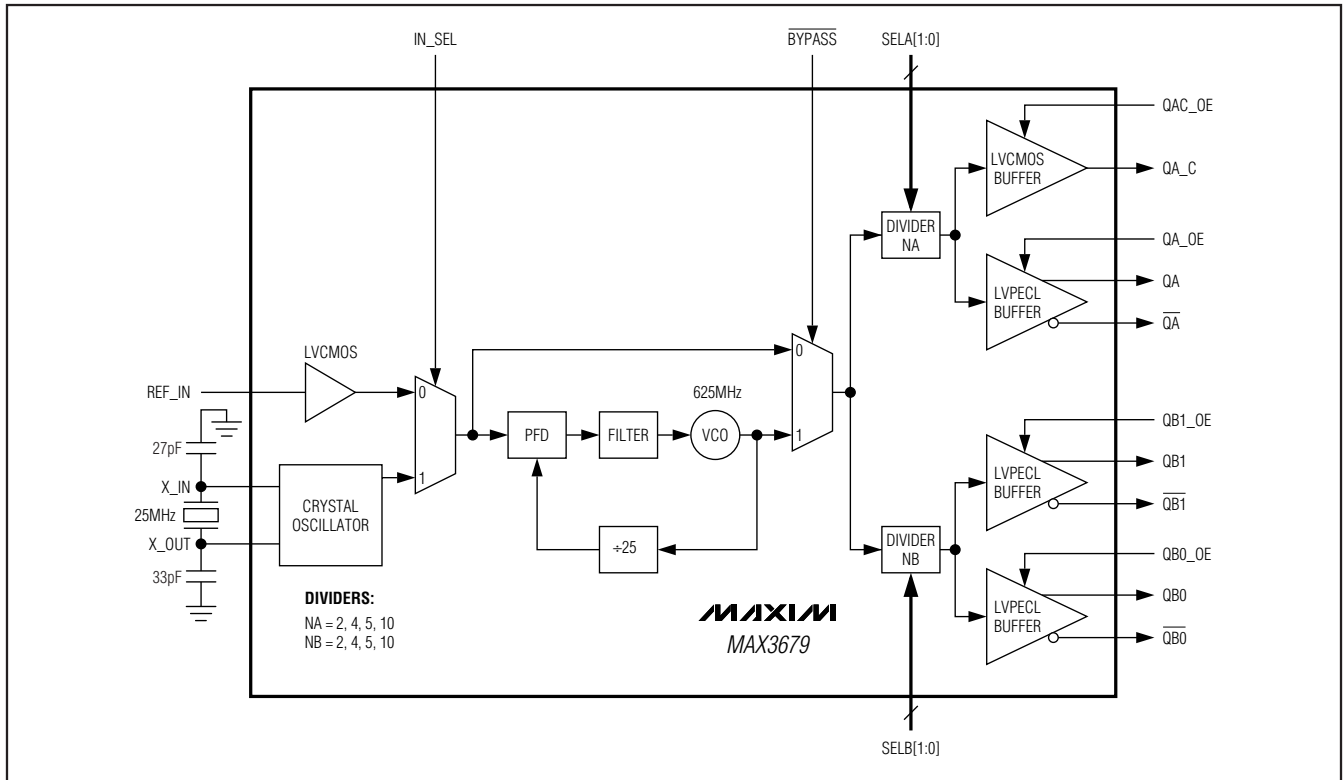

Package Information

For the latest package outline information and land patterns, go to www.maxim-ic.com/packages.

PACKAGE TYPE	PACKAGE CODE	DOCUMENT NO.
32 TQFN-EP	T3255+3	21-0140

Maxim cannot assume responsibility for use of any circuitry other than circuitry entirely embodied in a Maxim product. No circuit patent licenses are implied. Maxim reserves the right to change the circuitry and specifications without notice at any time.

Maxim Integrated Products, 120 San Gabriel Drive, Sunnyvale, CA 94086 408-737-7600 _____ 11

Looking for pricing, stock, or lifecycle information?

Click below to explore more details on WIN SOURCE:

 [View MAX3679CTJ+T on WIN SOURCE](#)

 [Microsemi Corporation](#) Information

Optimize Your Supply Chain with WIN SOURCE Solutions

-  Global Sourcing Solution
-  Obsolete Management
-  Cost Control Management
-  Shortage Management
-  Alternative Solution
-  Excess Inventory Management