



**THE DATASHEET OF  
MAX3450EEUD+T**





# ±15kV ESD-Protected USB Transceivers

MAX3450E/MAX3451E/MAX3452E

## General Description

The MAX3450E/MAX3451E/MAX3452E USB-compliant transceivers interface low-voltage ASICs with USB devices. The devices fully comply with USB 1.1 and USB 2.0 when operating at full (12Mbps) and low (1.5Mbps) speeds. The MAX3450E/MAX3451E/MAX3452E operate with  $V_L$  as low as +1.65V, ensuring compatibility with low-voltage ASICs.

The MAX3450E/MAX3451E/MAX3452E feature a logic-selectable suspend mode that reduces current consumption to less than 40µA. Integrated ±15kV ESD protection protects the USB D+ and D- bidirectional bus connections. The MAX3450E is pin compatible with Micrel's MIC2550A. The MAX3451E features an internal 1.5kΩ USB pullup resistor and an enumeration function that allows devices to logically disconnect while plugged in. The MAX3452E provides a push-pull bus-detect (BD) output that asserts high when  $V_{BUS}$  is greater than +4.0V.

The MAX3450E/MAX3451E/MAX3452E operate over the -40°C to +85°C extended temperature range and are available in 14-pin TSSOP and 3mm x 3mm 16-pin Thin QFN packages.

## Applications

- PDA's
- PC Peripherals
- Cellular Telephones
- Data Cradles
- MP3 Players

Typical Operating Circuit appears at end of data sheet.

## Features

- ◆ ±15kV ESD Protection on D+ and D-
- ◆ Combined VP and VM Inputs/Outputs
- ◆ +1.65V to +3.6V  $V_L$  Logic Supply Input for Interfacing with Low-Voltage ASICs
- ◆ Enumerate Input Function (MAX3451E)
- ◆ Powered from Li+ Battery as Low as +3.1V (MAX3450E and MAX3451E)
- ◆  $V_{BUS}$  Detection (MAX3452E)
- ◆ Pin Compatible with Micrel MIC2550A (MAX3450E)
- ◆ Internal D+ or D- Pullup Resistor (MAX3451E)
- ◆ No Power-Supply Sequencing Required

## Ordering Information

PART	PIN-PACKAGE	TOP MARK
MAX3450EEUD+	14 TSSOP	—
MAX3450EETE+	16 Thin QFN-EP†	AAJ
MAX3451EEUD+	14 TSSOP	—
MAX3451EETE+	16 Thin QFN-EP†	AAK
MAX3452EEUD+	14 TSSOP	—
MAX3452EETE+	16 Thin QFN-EP†	AAL

**Note:** All devices are specified over the -40°C to +85°C operating temperature range.  
 + Denotes lead (Pb)-free package/RoHS-compliant package.  
 † EP = Exposed pad.

## Pin Configurations

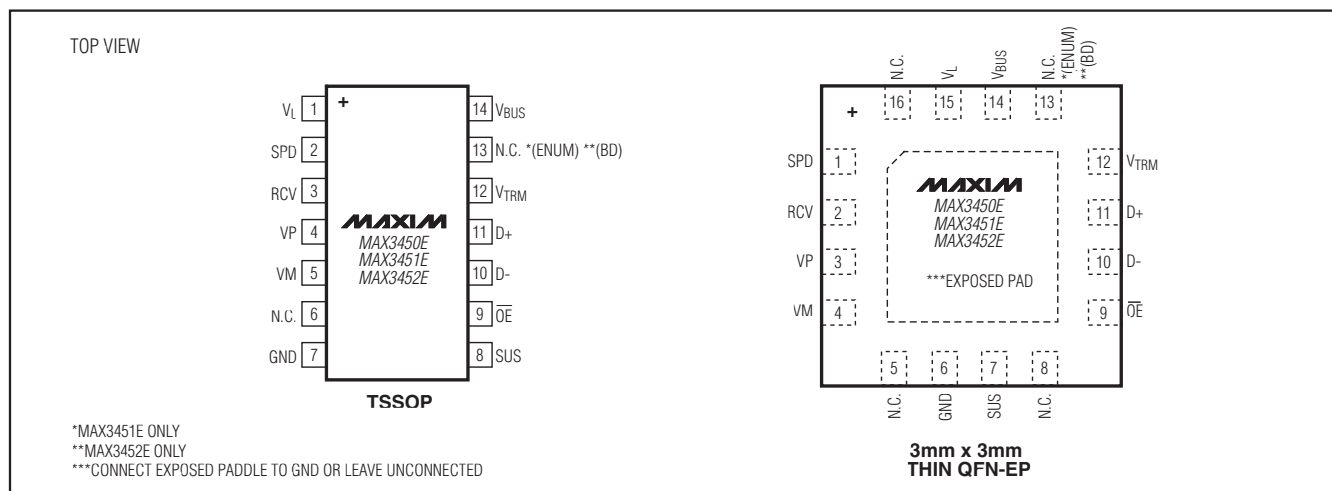

# ±15kV ESD-Protected USB Transceivers

## ABSOLUTE MAXIMUM RATINGS

V <sub>BUS</sub> , V <sub>L</sub> , D+, D- to GND.....	-0.3V to +6.0V
V <sub>TRM</sub> to GND .....	-0.3V to (V <sub>BUS</sub> + 0.3V)
VP, VM, SUS, SPD, ENUM, RCV, $\overline{OE}$ , BD to GND .....	-0.3V to (V <sub>L</sub> + 0.3V)
Current (into any pin).....	±15mA
Short-Circuit Current (D+ and D-) .....	±150mA
Continuous Power Dissipation (T <sub>A</sub> = +70°C)	
14-Pin TSSOP	
(derate 10mW/°C above +70°C).....	797mW
16-Pin Thin QFN-EP 3mm x 3mm	
(derate 20.8mW/°C above +70°C).....	1667mW

Package Junction-to-Ambient Thermal Resistance (θ <sub>JA</sub> ) (Note 1)	
14-Pin TSSOP.....	100.4°C/W
16-Pin Thin QFN-EP .....	48°C/W
Package Junction-to-Case Thermal Resistance (θ <sub>JC</sub> ) (Note 1)	
14-Pin TSSOP.....	30°C/W
16-Pin Thin QFN-EP .....	7°C/W
Operating Temperature Range .....	-40°C to +85°C
Junction Temperature .....	+150°C
Storage Temperature Range .....	-65°C to +150°C
Lead Temperature (soldering, 10s) .....	+300°C

**Note 1:** Package thermal resistances were obtained using the method described in JEDEC specifications. For detailed information on package thermal considerations, refer to [www.maxim-ic.com/thermal-tutorial](http://www.maxim-ic.com/thermal-tutorial).

Stresses beyond those listed under “Absolute Maximum Ratings” may cause permanent damage to the device. These are stress ratings only, and functional operation of the device at these or any other conditions beyond those indicated in the operational sections of the specifications is not implied. Exposure to absolute maximum rating conditions for extended periods may affect device reliability.

## DC ELECTRICAL CHARACTERISTICS

(V<sub>BUS</sub> = +4.0V to +5.5V or V<sub>TRM</sub> = +3.0V to +3.6V, V<sub>L</sub> = +1.65V to +3.6V, T<sub>A</sub> = T<sub>MIN</sub> to T<sub>MAX</sub>, unless otherwise noted. Typical values are at V<sub>BUS</sub> = +5.0V, V<sub>L</sub> = +2.5V, and T<sub>A</sub> = +25°C.) (Note 2)

PARAMETER	SYMBOL	CONDITIONS	MIN	TYP	MAX	UNITS
<b>SUPPLY INPUTS (V<sub>BUS</sub>, V<sub>TRM</sub>, V<sub>L</sub>)</b>						
Regulated Supply Voltage Output	V <sub>TRM</sub>	Internal regulator	3.0	3.3	3.6	V
Operating Supply Current	I <sub>VBUS</sub>	Full-speed transmitting/receiving at 12Mbps, C <sub>L</sub> = 50pF on D+ and D- (Note 3)			10	mA
Operating V <sub>L</sub> Supply Current	I <sub>VL</sub>	Full-speed transmitting/receiving at 12Mbps (Note 3)			2.5	mA
Full-Speed Idle and SE0 Supply Current	I <sub>VBUS(IDLE)</sub>	Full-speed idle: V <sub>D+</sub> > 2.7V, V <sub>D-</sub> < 0.3V		250	350	μA
		SE0: V <sub>D+</sub> < 0.3V, V <sub>D-</sub> < 0.3V		250	350	
Static V <sub>L</sub> Supply Current	I <sub>VL(STATIC)</sub>	Full-speed idle, SE0, or suspend mode	MAX3450E, MAX3451E		5	μA
			MAX3452E		15	
Suspend Supply Current	I <sub>VBUS(SUSP)</sub>	VM = VP = open, SUS = $\overline{OE}$ = high	MAX3450E, MAX3451E (ENUM = low)		35	μA
			MAX3452E		40	
Disable-Mode Supply Current	I <sub>VBUS(DIS)</sub>	V <sub>L</sub> = GND or open			20	μA
Sharing-Mode V <sub>L</sub> Supply Current	I <sub>VL(SHARING)</sub>	V <sub>BUS</sub> = GND or open, $\overline{OE}$ = low, VP = low or high, VM = low or high, SUS = high	MAX3450E, MAX3451E		5	μA
			MAX3452E		20	
D+/D- Sharing-Mode Load Current	I <sub>D_(SHARING)</sub>	V <sub>BUS</sub> = GND or open, V <sub>D-</sub> = 0 or +5.5V			20	μA
D+/D- Disable-Mode Load Current	I <sub>D_(DIS)</sub>	V <sub>L</sub> = GND or open, V <sub>D-</sub> = 0 or +5.5V			5	μA

# ±15kV ESD-Protected USB Transceivers

MAX3450E/MAX3451E/MAX3452E

## DC ELECTRICAL CHARACTERISTICS (continued)

(V<sub>BUS</sub> = +4.0V to +5.5V or V<sub>TRM</sub> = +3.0V to +3.6V, V<sub>L</sub> = +1.65V to +3.6V, T<sub>A</sub> = T<sub>MIN</sub> to T<sub>MAX</sub>, unless otherwise noted. Typical values are at V<sub>BUS</sub> = +5.0V, V<sub>L</sub> = +2.5V, and T<sub>A</sub> = +25°C.) (Note 1)

PARAMETER	SYMBOL	CONDITIONS	MIN	TYP	MAX	UNITS
USB Power-Supply Detection Threshold	V <sub>TH_VBUS</sub>	MAX3450E/MAX3451E, supply lost			0.8	V
		MAX3450E/MAX3451E, supply present (Note 4)	3.6			
		MAX3452E, supply lost			3.6	
		MAX3452E, supply present	4.0			
USB Power-Supply Detection Hysteresis	V <sub>HYST_VBUS</sub>	MAX3450E/MAX3451E		75		mV
		MAX3452E		40		
V <sub>L</sub> Power-Supply Detection Threshold	V <sub>TH_VL</sub>			0.85		V
<b>DIGITAL INPUTS/OUTPUTS (VP, VM, RCV, SUS, OE, SPD, BD, ENUM)</b>						
Input Voltage Low	V <sub>IL</sub>	VM, VP, SUS, SPD, ENUM, $\overline{OE}$			0.3 x V <sub>L</sub>	V
Input Voltage High	V <sub>IH</sub>	VM, VP, SUS, SPD, ENUM, $\overline{OE}$	0.7 x V <sub>L</sub>			V
Output Voltage Low	V <sub>OL</sub>	VM, VP, RCV, BD, I <sub>OL</sub> = +2mA			0.4	V
Output Voltage High	V <sub>OH</sub>	VM, VP, RCV, BD, I <sub>OH</sub> = -2mA	V <sub>L</sub> - 0.4			V
Input Leakage Current	I <sub>LKG</sub>		-1		+1	μA
Input Capacitance	C <sub>IN</sub>	Measured from input to GND		10		pF
<b>ANALOG INPUTS/OUTPUTS (D+, D-)</b>						
Differential Input Sensitivity	V <sub>ID</sub>	V <sub>D+</sub> - V <sub>D-</sub>	0.2			V
Differential Common-Mode Voltage	V <sub>CM</sub>	Includes V <sub>ID</sub> range	0.8		2.5	V
Single-Ended Input Low Voltage	V <sub>ILSE</sub>				0.8	V
Single-Ended Input High Voltage	V <sub>IHSE</sub>		2.0			V
Hysteresis	V <sub>HYST</sub>			250		mV
Output Voltage Low	V <sub>OLD</sub>	R <sub>L</sub> = 1.5kΩ to +3.6V			0.3	V
Output Voltage High	V <sub>OHD</sub>	R <sub>L</sub> = 15kΩ to GND	2.8		3.6	V
Off-State Leakage Current	I <sub>LZ</sub>		-1		+1	μA
Transceiver Capacitance	C <sub>IND</sub>	Measured from D <sub>-</sub> to GND		20		pF
Driver Output Impedance	Z <sub>DRV</sub>	Steady-state drive	4.0		15.5	Ω
Input Impedance	Z <sub>IN</sub>	Driver off	10			MΩ
Internal Pullup Resistance	R <sub>PULLUP</sub>	I <sub>LOAD</sub> = 500μA (MAX3451E) (Note 5)	1.425		1.575	kΩ
<b>ESD PROTECTION (D+, D-)</b>						
Human Body Model				±15		kV
IEC 1000-4-2 Contact Discharge				±8		kV

# ±15kV ESD-Protected USB Transceivers

## TIMING CHARACTERISTICS

( $V_{BUS} = +4.0V$  to  $+5.5V$  or  $V_{TRM} = +3.0V$  to  $+3.6V$ ,  $V_L = +1.65V$  to  $+3.6V$ ,  $T_A = T_{MIN}$  to  $T_{MAX}$ , unless otherwise noted. Typical values are at  $V_{BUS} = +5V$ ,  $V_L = +2.5V$ , and  $T_A = +25^\circ C$ .) (Note 1)

PARAMETER	SYMBOL	CONDITIONS	MIN	TYP	MAX	UNITS
<b>DRIVER CHARACTERISTICS (FULL-SPEED MODE, <math>C_L = 50pF</math>)</b>						
Rise Time	$t_{FR}$	10% to 90% of $ V_{OHD} - V_{OLD} $ , Figures 1, 6	4		20	ns
Fall Time	$t_{FF}$	90% to 10% of $ V_{OHD} - V_{OLD} $ , Figures 1, 6	4		20	ns
Rise-/Fall-Time Matching (Note 3)	$t_{FR}/t_{FF}$	Excluding the first transition from idle state, (Figures 1, 6)	90		110	%
Output-Signal Crossover Voltage (Note 3)	$V_{CRS\_F}$	Excluding the first transition from idle state, (Figures 2, 6)	1.3		2.0	V
Driver Propagation Delay (Figures 2, 6)	$t_{PLH\_DRV}$	Low-to-high transition			18	ns
	$t_{PHL\_DRV}$	High-to-low transition			18	
Driver Disable Delay (Figure 3)	$t_{PHZ\_DRV}$	High-to-off transition			20	ns
	$t_{PLZ\_DRV}$	Low-to-off transition			20	
Driver Enable Delay (Figure 3)	$t_{PZH\_DRV}$	Off-to-high transition			20	ns
	$t_{PZL\_DRV}$	Off-to-low transition			20	
<b>DRIVER CHARACTERISTICS (LOW-SPEED MODE, <math>C_L = 200pF</math> TO <math>600pF</math>)</b>						
Rise Time	$t_{LR}$	10% to 90% of $ V_{OHD} - V_{OLD} $ , Figures 1, 6	75		300	ns
Fall Time	$t_{LF}$	90% to 10% of $ V_{OHD} - V_{OLD} $ , Figures 1, 6	75		300	ns
Rise-/Fall-Time Matching	$t_{LR}/t_{LF}$	Excluding the first transition from idle state, Figures 1, 6	80		125	%
Output-Signal Crossover Voltage	$V_{CRS\_L}$	Excluding the first transition from idle state, Figures 2, 6	1.3		2.0	V
<b>RECEIVER CHARACTERISTICS (<math>C_L = 15pF</math>)</b>						
Differential Receiver Propagation Delay, Figures 4, 6	$t_{PLH\_RCV}$	Low-to-high transition			22	ns
	$t_{PHL\_RCV}$	High-to-low transition			22	
Single-Ended Receiver Propagation Delay, Figures 4, 6	$t_{PLH\_SE}$	Low-to-high transition			12	ns
	$t_{PHL\_SE}$	High-to-low transition			12	
Single-Ended Receiver Disable Delay, Figure 5	$t_{PHZ\_SE}$	High-to-off transition			15	ns
	$t_{PLZ\_SE}$	Low-to-off transition			15	
Single-Ended Receiver Enable Delay, Figure 5	$t_{PZH\_SE}$	Off-to-high transition			15	ns
	$t_{PZL\_SE}$	Off-to-low transition			15	

**Note 2:** Parameters are 100% production tested at  $+25^\circ C$ , unless otherwise noted. Limits over temperature are guaranteed by design.

**Note 3:** Guaranteed by design, not production tested.

**Note 4:** Production tested to  $+2.7V$  for  $V_L \leq +3.0V$ .

**Note 5:** Including external  $24.3\Omega$  series resistor.

# ±15kV ESD-Protected USB Transceivers

## Typical Operating Characteristics

( $V_{BUS} = +5.0V$ ,  $V_L = +3.3V$ ,  $T_A = +25^\circ C$ , unless otherwise noted.)

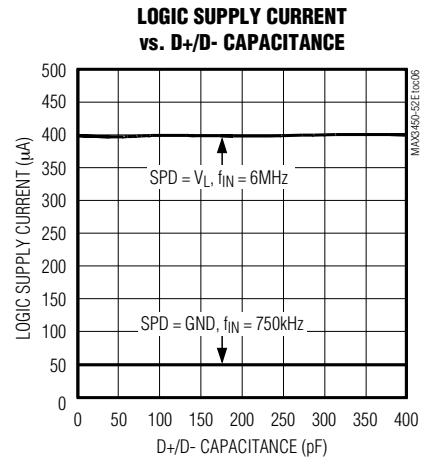
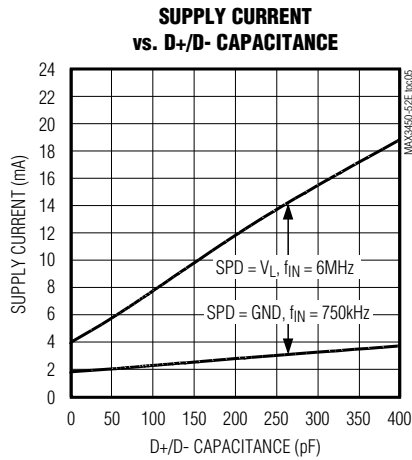
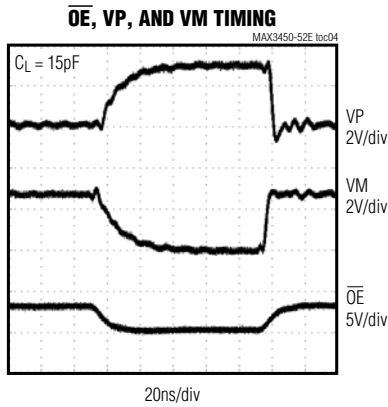
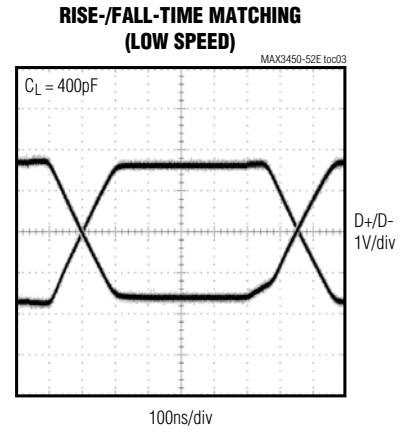
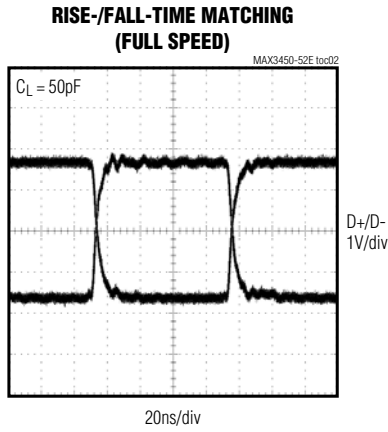
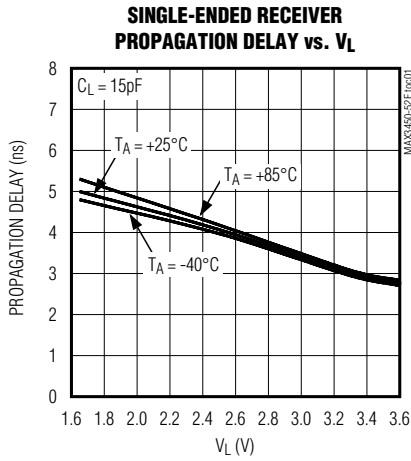

MAX3450E/MAX3451E/MAX3452E

# ±15kV ESD-Protected USB Transceivers

## Pin Description

PIN		NAME	FUNCTION
TSSOP	THIN QFN-EP		
1	15	V <sub>L</sub>	Digital I/O Connections Logic Supply. Connect a +1.65V to +3.6V supply to V <sub>L</sub> . Bypass V <sub>L</sub> to GND with a 0.1µF ceramic capacitor.
2	1	SPD	Speed-Selector Input. Connect SPD to GND to select the low-speed data rate (1.5Mbps). Connect SPD to V <sub>L</sub> to select the full-speed data rate (12Mbps).
3	2	RCV	Differential-Receiver Output. RCV responds to the differential input on D+ and D- (Tables 3 and 4). RCV asserts low if SUS = V <sub>L</sub> .
4	3	VP	Receiver Output/Driver Input. VP functions as a receiver output when $\overline{OE} = V_L$ . VP duplicates D+ when receiving. VP functions as a driver input when $\overline{OE} = GND$ .
5	4	VM	Receiver Output/Driver Input. VM functions as a receiver output when $\overline{OE} = V_L$ . VM duplicates D- when receiving. VM functions as a driver input when $\overline{OE} = GND$ .
6	5, 8, 16	N.C.	No Connection. Not internally connected.
7	6	GND	Ground
8	7	SUS	Suspend Input. Drive SUS low for normal operation. Drive SUS high to put the MAX3450E/MAX3451E/MAX3452E into suspend mode. RCV asserts low in suspend mode. VP and VM remain active in suspend mode.
9	9	$\overline{OE}$	Output Enable. Drive $\overline{OE}$ to GND to enable the transmitter outputs. Drive $\overline{OE}$ to V <sub>L</sub> to disable the transmitter outputs. $\overline{OE}$ also controls the I/O direction of VP and VM (Tables 3 and 4).
10	10	D-	USB Input/Output. For $\overline{OE} = GND$ , D- functions as a USB output, with VM providing the input signal. For $\overline{OE} = V_L$ , D- functions as a USB input, with VM functioning as a single-ended receiver output. Connect a 1.5kΩ resistor from D- to V <sub>TRM</sub> for low-speed (1.5Mbps) operation (MAX3450E and MAX3452E).
11	11	D+	USB Input/Output. For $\overline{OE} = GND$ , D+ functions as a USB output, with VP providing the input signal. For $\overline{OE} = V_L$ , D+ functions as a USB input, with VP functioning as a single-ended receiver output. Connect a 1.5kΩ resistor from D+ to V <sub>TRM</sub> for full-speed (12Mbps) operation (MAX3450E and MAX3452E).
12	12	V <sub>TRM</sub>	Internal Regulator Output. V <sub>TRM</sub> provides a regulated +3.3V output. Bypass V <sub>TRM</sub> to GND with a 1µF (min) ceramic capacitor as close to the device as possible. V <sub>TRM</sub> normally derives power from V <sub>BUS</sub> . Alternatively, drive V <sub>TRM</sub> directly with a +3.3V ±10% supply (MAX3450E and MAX3451E). V <sub>TRM</sub> provides power to internal circuitry and provides the pullup voltage for an external USB pullup resistor (MAX3450E and MAX3452E). Do not use V <sub>TRM</sub> to power external circuitry.
13	13	N.C.	No Connection. Not internally connected (MAX3450E).
		ENUM	Enumerate Function Selection Input (MAX3451E). Drive ENUM to V <sub>L</sub> to connect the internal 1.5kΩ resistor between V <sub>TRM</sub> and D+ or D-, depending on the SPD state. Drive ENUM to GND to disconnect the internal 1.5kΩ resistor. For SPD = V <sub>L</sub> , the 1.5kΩ pullup resistor connects to D+. For SPD = GND, the 1.5kΩ pullup resistor connects to D-.
		BD	Bus-Detection Output (MAX3452E). The push-pull BD output asserts low and the device enters sharing mode if V <sub>BUS</sub> < +3.6V. BD asserts high if V <sub>BUS</sub> > +4.0V.
14	14	V <sub>BUS</sub>	USB Power-Supply Input. Connect a +4.0V to +5.5V power supply to V <sub>BUS</sub> . V <sub>BUS</sub> provides power to the internal linear regulator. Bypass V <sub>BUS</sub> to GND with a 0.1µF ceramic capacitor as close to the device as possible. Connect V <sub>BUS</sub> and V <sub>TRM</sub> together when powering the MAX3450E or MAX3451E with an external power supply (+3.3V ±10%).
—	—	EP	Exposed Pad. Connect exposed pad to ground.

# ±15kV ESD-Protected USB Transceivers

## Functional Diagram

MAX3450E/MAX3451E/MAX3452E

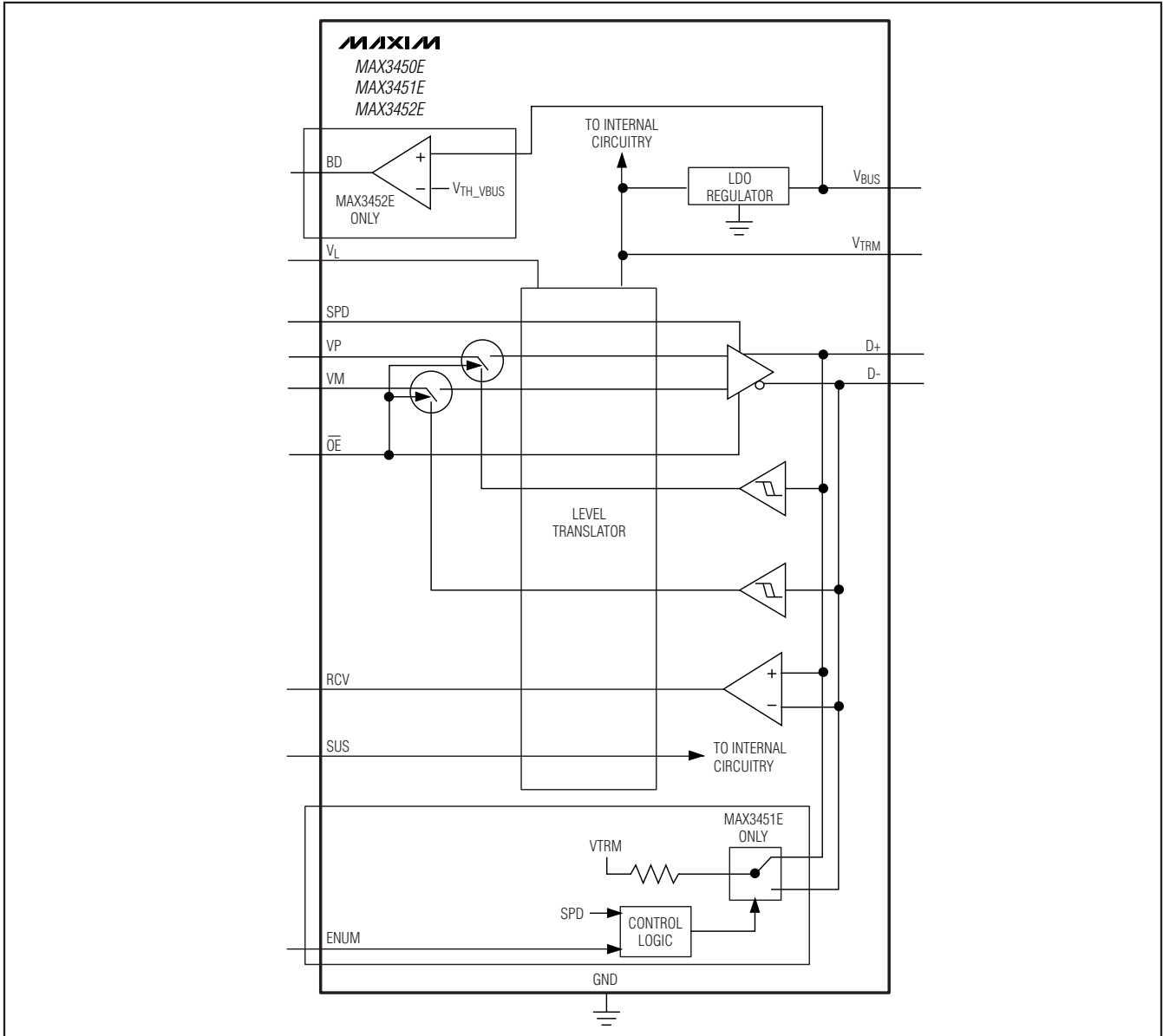

### Detailed Description

The MAX3450E/MAX3451E/MAX3452E USB-compliant transceivers convert single-ended or differential logic-level signals to USB signals and USB signals to single-ended or differential logic-level signals. The devices fully comply with USB 1.1, as well as USB 2.0 at full- (12Mbps) and low-speed (1.5Mbps) operation. The MAX3450E/MAX3451E/MAX3452E operate with  $V_L$

as low as +1.65V, ensuring compatibility with low-voltage ASICs.

The MAX3450E/MAX3451E/MAX3452E derive power from the USB host ( $V_{BUS}$ ) or from a single-cell Li+ battery (MAX3450E and MAX3451E) connected to  $V_{BUS}$  or from a +3.3V regulated supply connected to  $V_{BUS}$  and  $V_{TRM}$ . The MAX3450E/MAX3451E/MAX3452E meet the physical-layer specifications for logic-level supply volt-

# ±15kV ESD-Protected USB Transceivers

ages ( $V_L$ ) from +1.65V to +3.6V. Integrated ±15kV ESD protection protects the D+ and D- USB I/O ports.

The MAX3451E features an enumerate function providing an internal 1.5kΩ pullup resistor to  $V_{TRM}$ . The enumerate function disconnects the 1.5kΩ pullup resistor, allowing the MAX3451E to simulate a bus disconnect while powered and connected to the USB cable. The MAX3450E is pin-for-pin compatible with Micrel's MIC2550A. The MAX3452E features a BD output that asserts high if  $V_{BUS}$  is greater than +4.0V. BD asserts low if  $V_{BUS}$  is less than +3.6V. The MAX3450E and MAX3452E require external pullup resistors from either D+ or D- to  $V_{TRM}$  to set the bus speed.

## Applications Information

### Power-Supply Configurations

#### Normal Operating Mode

Connect  $V_L$  and  $V_{BUS}$  to system power supplies (Table 1). Connect  $V_L$  to a +1.65V to +3.6V supply. Connect  $V_{BUS}$  to a +4.0V to +5.5V supply. Alternatively, the MAX3450E and MAX3451E can derive power from

a single Li+ battery. Connect the battery to  $V_{BUS}$ .  $V_{TRM}$  remains above +3.0V for  $V_{BUS}$  as low as +3.1V.

Additionally, the MAX3450E and MAX3451E can derive power from a +3.3V ±10% voltage regulator. Connect  $V_{BUS}$  and  $V_{TRM}$  to an external +3.3V voltage regulator.  $V_{BUS}$  no longer consumes current to power the internal linear regulator in this configuration.

#### Disable Mode

Connect  $V_{BUS}$  to a system power supply and leave  $V_L$  unconnected or connect to GND. D+ and D- enter a tri-state mode and  $V_{BUS}$  (or  $V_{BUS}$  and  $V_{TRM}$ ) consumes less than 20μA of supply current. D+ and D- withstand external signals up to +5.5V in disable mode (Table 2).

#### Sharing Mode

Connect  $V_L$  to a system power supply and leave  $V_{BUS}$  (or  $V_{BUS}$  and  $V_{TRM}$ ) unconnected or connect to GND. D+ and D- enter a tri-state mode, allowing other circuitry to share the USB D+ and D- lines, and  $V_L$  consumes less than 20μA of supply current. D+ and D- withstand external signals up to +5.5V in sharing mode (Table 2).

**Table 1. Power-Supply Configurations**

$V_{BUS}$ (V)	$V_{TRM}$ (V)	$V_L$ (V)	CONFIGURATION	NOTES
+4.0 to +5.5	+3.0 to +3.6 output	+1.65 to +3.6	Normal mode	—
+3.1 to +4.5	+3.0 to +3.6 output	+1.65 to +3.6	Battery supply	MAX3450E, MAX3451E
+3.0 to +3.6	+3.0 to +3.6 input	+1.65 to +3.6	Voltage regulator supply	MAX3450E, MAX3451E
GND or floating	Output	+1.65 to +3.6	Sharing mode	Table 2
+3.0 to +5.5	$V_{BUS}$	GND or floating	Disable mode	Table 2

**Table 2. Disable-Mode and Sharing-Mode Connections**

INPUTS/OUTPUTS	DISABLE MODE	SHARING MODE
$V_{BUS}/V_{TRM}$	<ul style="list-style-type: none"> <li>+5V input/+3.3V output</li> <li>+3.3V input/+3.3V input (MAX3450E and MAX3451E)</li> <li>+3.7V input/+3.3V output (MAX3450E and MAX3451E)</li> </ul>	<ul style="list-style-type: none"> <li>Floating or connected to GND (MAX3450E and MAX3451)</li> <li>&lt; +3.6V (MAX3452E)</li> </ul>
$V_L$	Floating or connected to GND	+1.65V to +3.6V input
D+ and D-	High impedance	High impedance
VP and VM	Invalid*	High impedance for $\overline{OE}$ = low
		High for $\overline{OE}$ = high
RCV	Invalid*	Undefined**
SPD, SUS, $\overline{OE}$ , ENUM (MAX3451E)	High impedance	High impedance
BD (MAX3452E)	Invalid*	Low

\*High impedance or low

\*\*High or low

# ±15kV ESD-Protected USB Transceivers

MAX3450E/MAX3451E/MAX3452E

## Device Control

## SUS

$\overline{OE}$  controls the direction of communication. Drive  $\overline{OE}$  low to transfer data from the logic side to the USB side. For  $\overline{OE}$  = low, VP and VM serve as differential driver inputs to the USB transmitter.

Drive  $\overline{OE}$  high to transfer data from the USB side to the logic side. For  $\overline{OE}$  = high, VP and VM serve as single-ended receiver outputs from the USB inputs (D+ and D-). RCV serves as a differential receiver output, regardless of the state of OE.

The SUS state determines whether the MAX3450E/MAX3451E/MAX3452E operate in normal mode or in suspend mode. Connect SUS to GND to enable normal operation. Drive SUS high to enable suspend mode. RCV asserts low and VP and VM remain active in suspend mode (Tables 3 and 4). Supply current decreases in suspend mode (see the *Electrical Characteristics*).

## ENUM (MAX3451E)

The MAX3451E features an enumerate function that allows software control of USB enumeration. USB protocol requires a 1.5kΩ pullup resistor to D+ or D- to indicate the transmission speed to the host (see the *SPD* section). The MAX3451E provides an internal 1.5kΩ pullup resistor. Remove the pullup resistor from the circuit to simulate a device disconnect from the USB. Drive ENUM low to disconnect the internal pullup resistor. Drive ENUM high to connect the internal pullup resistor. The SPD state determines whether the pullup resistor connects to D+ or D-. For ENUM = high, the internal 1.5kΩ pullup resistor connects to D+ when SPD = VL (full speed) or to D- when SPD = GND (low speed).

**Table 3a. Transmit Truth Table**  
( $\overline{OE}$  = 0, SUS = 0)

INPUTS		OUTPUTS			OUTPUT STATE
VP	VM	D+	D-	RCV	
0	0	0	0	X	SEO
0	1	0	1	0	Logic 0
1	0	1	0	1	Logic 1
1	1	1	1	X	Undefined

X = Undefined.

**Table 3b. Transmit Truth Table**  
( $\overline{OE}$  = 0, SUS = 1)

INPUTS		OUTPUTS			OUTPUT STATE
VP	VM	D+	D-	RCV	
0	0	0	0	0	SEO
0	1	0	1	0	Logic 0
1	0	1	0	0	Logic 1
1	1	1	1	0	Undefined

**Table 4a. Receive Truth Table**  
( $\overline{OE}$  = 1 and SUS = 0)

INPUTS		OUTPUTS			OUTPUT STATE
D+	D-	VP	VM	RCV	
0	0	0	0	X	SEO
0	1	0	1	0	Logic 0
1	0	1	0	1	Logic 1
1	1	1	1	X	Undefined

X = Undefined.

## SPD

SPD sets the transceiver speed. Connect SPD to GND to select the low-speed data rate (1.5Mbps). Connect SPD to VL to select the full-speed data rate (12Mbps). The MAX3451E provides an internal pullup resistor for selecting the bus speed. The MAX3450E and MAX3452E require an external pullup resistor to D+ or D- to set the bus speed. Connect the 1.5kΩ resistor between D+ and VTRM to set the full-speed (12Mbps) data rate, or connect the 1.5kΩ resistor between D- and VTRM to set the low-speed (1.5 Mbps) data rate.

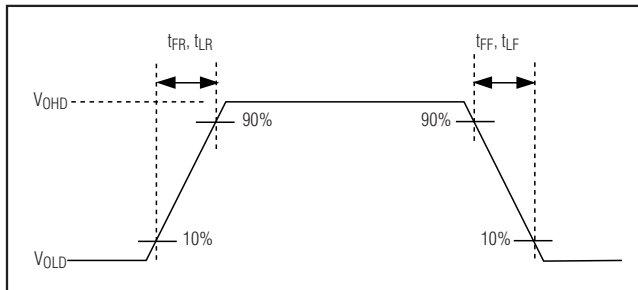

Figure 1. Rise and Fall Times

# ±15kV ESD-Protected USB Transceivers

**Table 4b. Receive Truth Table**  
( $\overline{OE} = 1$  and  $SUS = 1$ )

INPUTS		OUTPUTS			OUTPUT STATE
D+	D-	VP	VM	RCV	
0	0	0	0	0	SE0
0	1	0	1	0	Logic 0
1	0	1	0	0	Logic 1
1	1	1	1	0	Undefined

### BD (MAX3452E)

The push-pull bus detect (BD) output monitors  $V_{BUS}$  and asserts high if  $V_{BUS}$  is greater than +4.0V. BD asserts low if  $V_{BUS}$  is less than +3.6V and the MAX3452E enters sharing mode (Table 2).

### $V_{TRM}$

An internal linear regulator generates the  $V_{TRM}$  voltage (+3.3V typ).  $V_{TRM}$  derives power from  $V_{BUS}$  (see the *Power-Supply Configurations* section).  $V_{TRM}$  powers the internal portions of the USB circuitry and provides the pullup voltage for an external USB pullup resistor MAX3450E/MAX3452E. Bypass  $V_{TRM}$  to GND with a 1 $\mu$ F ceramic capacitor as close to the device as possible. Do not use  $V_{TRM}$  to provide power to external circuitry.

### D+ and D-

D+ and D- serve as bidirectional bus connections and are ESD protected to ±15kV (Human Body Model). For  $\overline{OE} = \text{low}$ , D+ and D- serve as transmitter outputs. For  $\overline{OE} = \text{high}$ , D+ and D- serve as receiver inputs.

### $V_{BUS}$

For most applications,  $V_{BUS}$  connects to the  $V_{BUS}$  terminal on the USB connector.  $V_{BUS}$  can also connect to an external supply as low as +3.1V (MAX3450E and MAX3451E). See the *Power-Supply Configurations* section. Drive  $V_{BUS}$  low to enable sharing mode. Bypass  $V_{BUS}$  to GND with a 0.1 $\mu$ F ceramic capacitor as close to the device as possible.

## External Components

### External Resistors

Proper USB operation requires two external resistors, each 24.3 $\Omega$  ±1%, 1/8W (or greater). Install one resistor in series between D+ of the MAX3450E/MAX3451E/MAX3452E and D+ on the USB connector. Install the other resistor in series between D- of the MAX3450E/MAX3451E/MAX3452E and D- on the USB connector (see the *Typical Operating Circuit*).

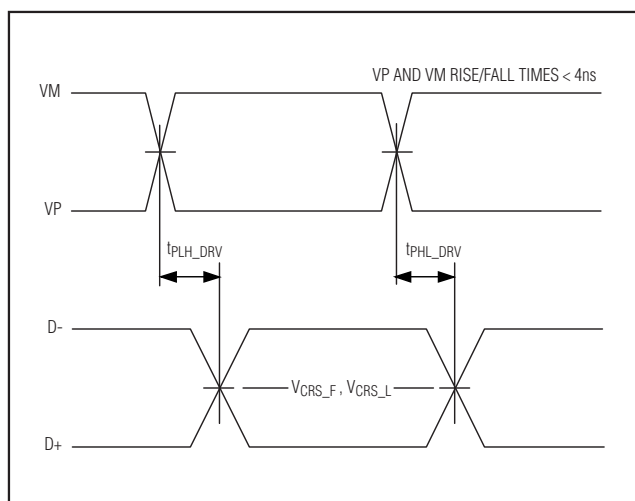

Figure 2. Timing of VP and VM to D+ and D-

The MAX3450E/MAX3452E requires an external 1.5k $\Omega$  pullup resistor between  $V_{TRM}$  and D+ or D- to set the bus speed.

### External Capacitors

The MAX3450E/MAX3451E/MAX3452E require three external capacitors for proper operation. Bypass  $V_L$  to GND with a 0.1 $\mu$ F ceramic capacitor. Bypass  $V_{BUS}$  to GND with a 0.1 $\mu$ F ceramic capacitor. Bypass  $V_{TRM}$  to GND with a 1 $\mu$ F (min) ceramic capacitor. Install all capacitors as close to the device as possible.

## Data Transfer

### Transmitting Data to the USB

The MAX3450E/MAX3451E/MAX3452E transmit data to the USB differentially on D+ and D-. VP and VM serve as differential input signals to the driver (Tables 3a and 3b).

### Receiving Data from the USB

To receive data from the USB, drive  $\overline{OE}$  high and  $SUS$  low. Differential data received by D+ and D- appears as a differential logic signal at RCV. Single-ended receivers on D+ and D- drive VP and VM, respectively (Tables 4a and 4b).

# ±15kV ESD-Protected USB Transceivers

MAX3450E/MAX3451E/MAX3452E

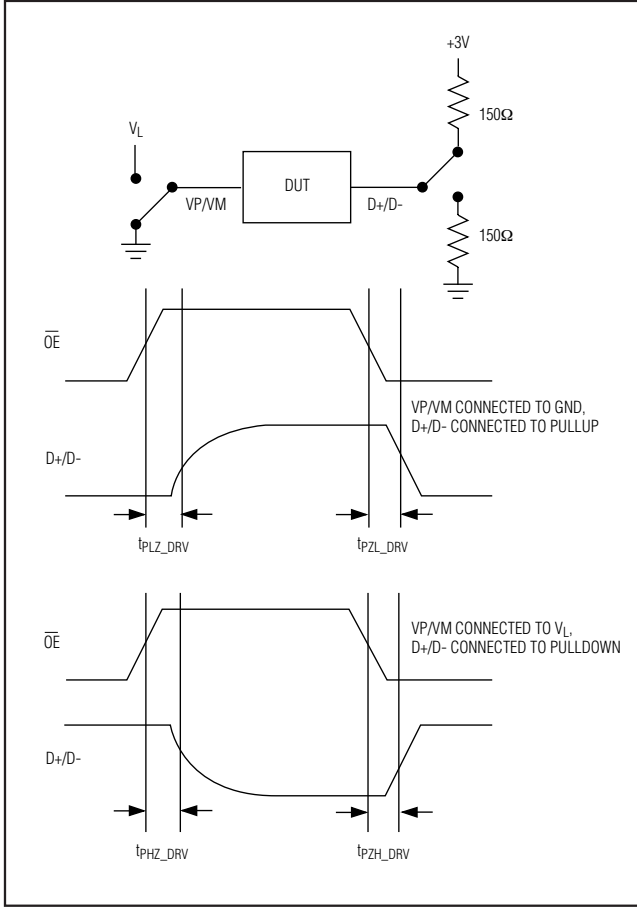

Figure 3. Enable and Disable Timing, Driver

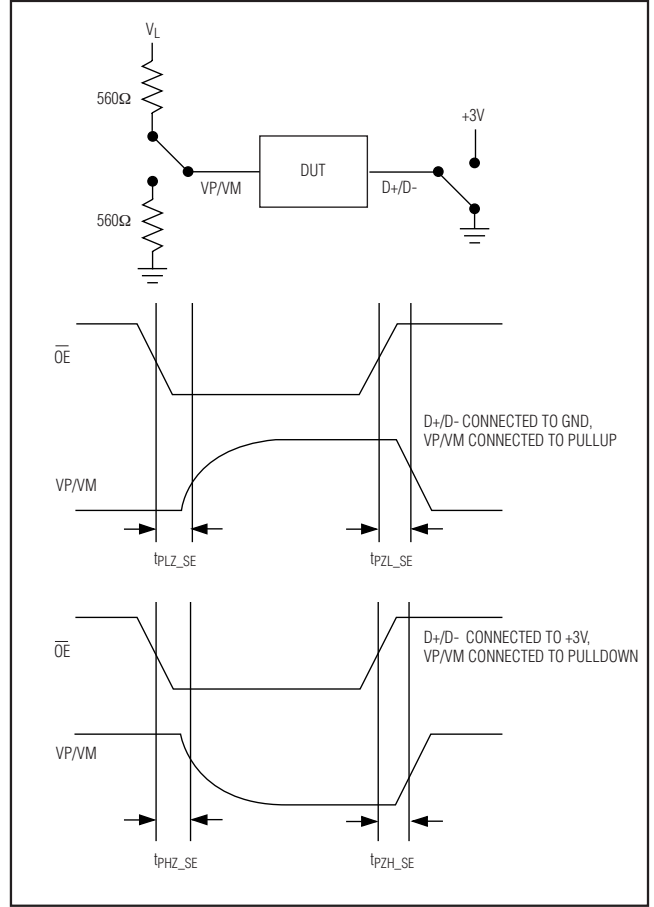

Figure 5. Enable and Disable Timing, Receiver

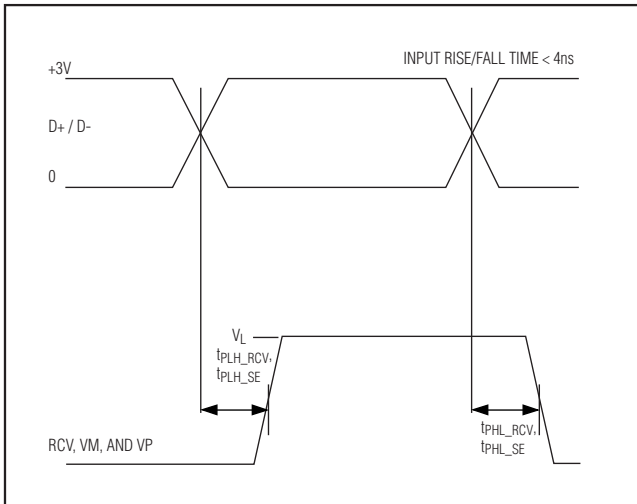

Figure 4. Timing of D+ and D- to RCV, VM, and VP

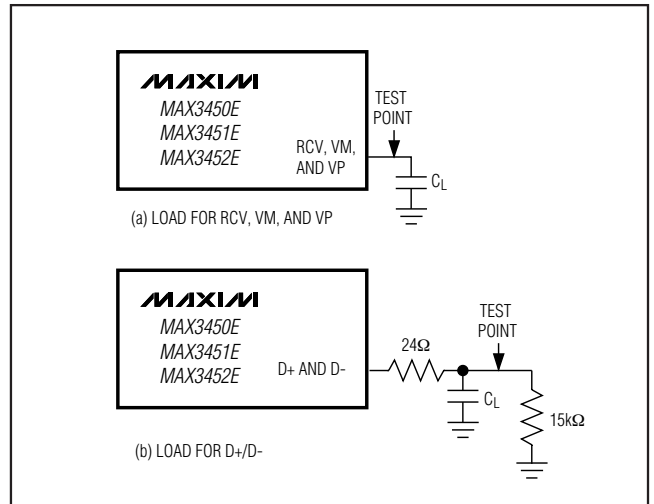

Figure 6. Test Circuits

# ±15kV ESD-Protected USB Transceivers

## ESD Protection

D+ and D- possess extra protection against static electricity to protect the devices up to ±15kV. The ESD structures withstand high ESD in all operating modes: normal operation, suspend mode, and powered down. D+ and D- provide protection to the following limits:

- ±15kV using the Human Body Model
- ±8kV using the Contact Discharge method specified in IEC 1000-4-2

### ESD Test Conditions

ESD performance depends on a variety of conditions. Contact Maxim for a reliability report that documents test setup, test methodology, and test results.

### Human Body Model

Figure 7 shows the Human Body Model and Figure 8 shows the current waveform generated when discharged into a low impedance. This model consists of a 100pF capacitor charged to the ESD voltage of interest, which then discharges into the test device through a 1.5kΩ resistor.

### IEC 1000-4-2

The IEC 1000-4-2 standard covers ESD testing and performance of finished equipment. It does not specifically refer to integrated circuits. The major difference between tests done using the Human Body Model and IEC 1000-4-2 is a higher peak current in IEC 1000-4-2, due to lower series resistance. Hence, the ESD withstand voltage measured to IEC 1000-4-2 generally is lower than that measured using the Human Body Model. Figure 9 shows the IEC 1000-4-2 model. The Contact Discharge method connects the probe to the device before the probe is charged.

### Machine Model

The Machine Model for ESD tests all connections using a 200pF storage capacitor and zero discharge resistance. Its objective is to emulate the stress caused by contact that occurs with handling and assembly during manufacturing. All pins require this protection during manufacturing, not just inputs and outputs. After PC board assembly, the Machine Model is less relevant to I/O ports.

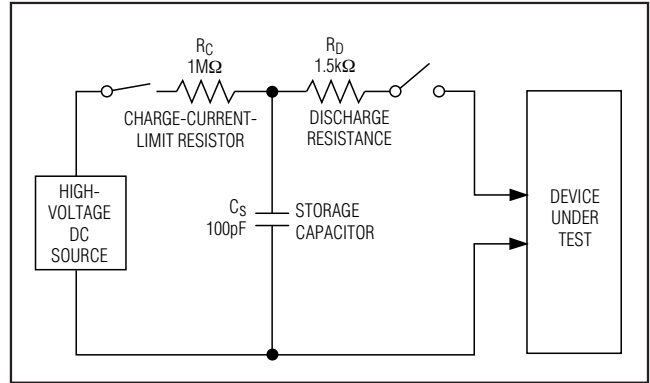

Figure 7. Human Body ESD Test Models

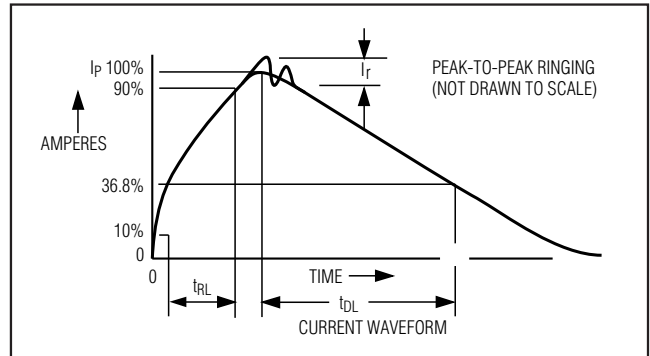

Figure 8. Human Body Model Current Waveform

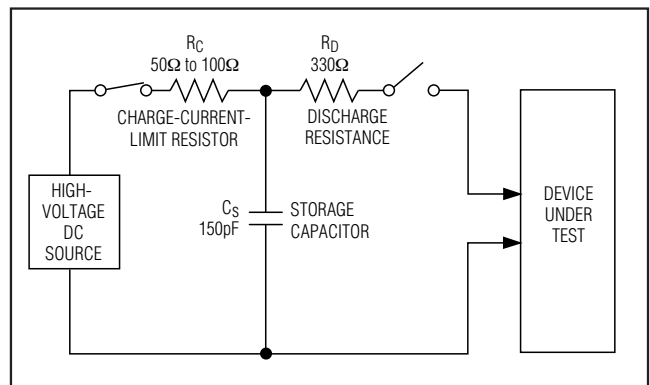
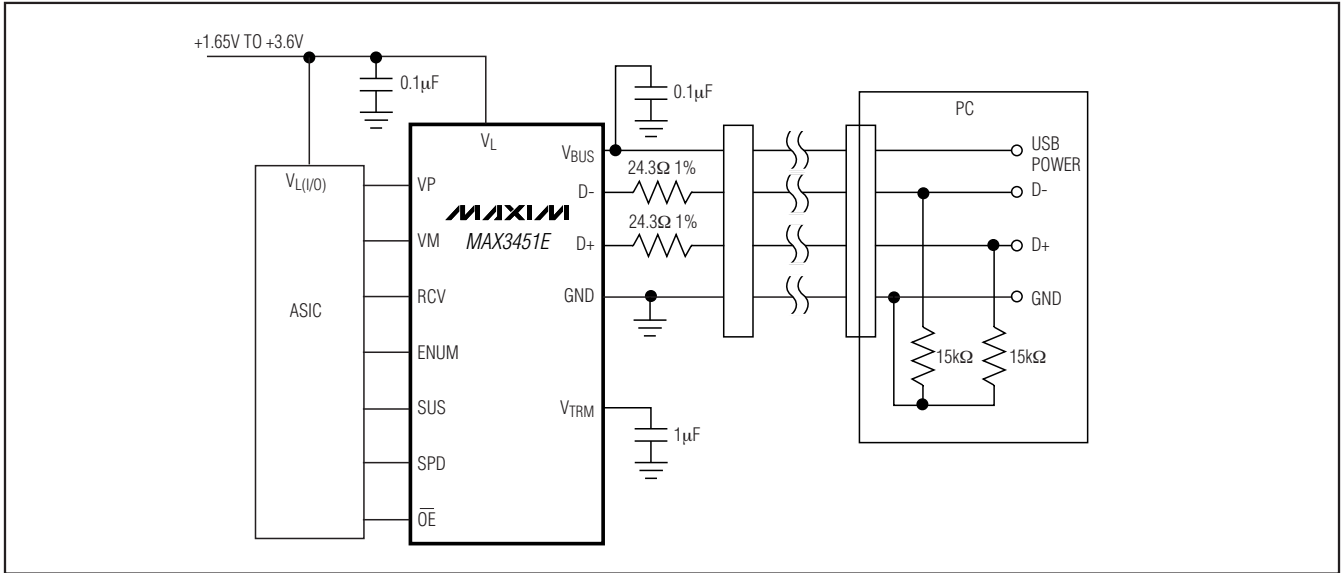

Figure 9. IEC 1000-4-2 ESD Test Model

# ±15kV ESD-Protected USB Transceivers

## Typical Operating Circuit



## Chip Information

PROCESS: BiCMOS

## Package Information

For the latest package outline information and land patterns, go to [www.maxim-ic.com/packages](http://www.maxim-ic.com/packages).

PACKAGE TYPE	PACKAGE CODE	DOCUMENT NO.
14 TSSOP	U14-1	<a href="#">21-0066</a>
16 Thin QFN-EP	T1633-4	<a href="#">21-0136</a>

MAX3450/MAX3451E/MAX3452E

# ±15kV ESD-Protected USB Transceivers

## Revision History



REVISION NUMBER	REVISION DATE	DESCRIPTION	PAGES CHANGED
0	4/03	Initial release	—
1	11/03	Changed specs	—
2	10/08	Added lead-free packaging. Updated <i>Absolute Maximum Ratings</i> information of package thermal resistances. Updated EC table notation.	1-4, 6

Maxim cannot assume responsibility for use of any circuitry other than circuitry entirely embodied in a Maxim product. No circuit patent licenses are implied. Maxim reserves the right to change the circuitry and specifications without notice at any time.

14 **Maxim Integrated Products, 120 San Gabriel Drive, Sunnyvale, CA 94086 408-737-7600**

## Looking for pricing, stock, or lifecycle information?

Click below to explore more details on WIN SOURCE:

-  [View MAX3450EEUD+T on WIN SOURCE](#)
-  [Maxim Integrated Information](#)

## Optimize Your Supply Chain with WIN SOURCE Solutions

-  Global Sourcing Solution
-  Obsolete Management
-  Cost Control Management
-  Shortage Management
-  Alternative Solution
-  Excess Inventory Management