



**THE DATASHEET OF  
MAX31912EVKIT#**



## MAX31912

## Ultra-Low Power Industrial, Octal, Digital Input Translator/Serializer

### General Description

The MAX31912 industrial interface serializer translates, conditions, and serializes the 24V digital output of sensors and switches used in industrial, process, and building automation to 5V CMOS-compatible signals required by microcontrollers. It provides the front-end interface circuit of a programmable logic controller (PLC) digital input module.

The device features integrated current limiting, lowpass filtering, and channel serialization. Input current limiting allows a significant reduction in power consumed from the field voltage supply as compared to traditional discrete resistor-divider implementations. Selectable on-chip lowpass filters allow flexible debouncing and filtering of sensor outputs based on the application.

On-chip serialization allows a drastic reduction in the number of optocouplers used for isolation. The device serializer is stackable so that any number of input channels can be serialized and output through only one SPI-compatible port. This reduces the number of optocouplers needed to only three, regardless of the number of input channels.

For enhanced robustness with respect to high-frequency noise and fast electrical transients, a multibit CRC code is generated and transmitted through the SPI port for each 8 bits of data. The on-chip 5V voltage regulator can be used to power external optocouplers, digital isolators, or other external 5V circuitry. Field-side LED drivers recycle the current from the eight inputs to provide visual input status indication without any additional current or power consumption.

The MAX31912 uses patent-pending circuit techniques to achieve further reduction of power beyond what is possible by input current limiting alone.

For low-cost applications, Maxim Integrated offers a pin-compatible version of this device, the MAX31913, which does not include the patent-pending current-switching circuitry included in the MAX31912.

### Benefits and Features

- Ultra-Low Power and Heat Dissipation
  - Low Quiescent Current (1.6mA, typ)
  - Highly Accurate and Stable Input Current Limiters, Adjustable from 0.5mA to 6mA
  - Special (Patent-Pending) Ultra-Low-Power Mode with Switched Current Limiters
  - Energy-Less Field-Side LED Drivers
- High Integration Reduces BOM Count, Board Size, and System Cost
  - 8 High-Voltage Input Channels (36V max)
  - On-Chip 8-1 Serialization with SPI Interface,
  - On-Chip 5V Regulator
  - On-Chip Overtemperature Indicator
  - Dual On-Chip Field Supply Voltage Monitors
  - Integrated Debounce Filters, Selectable from 0 to 3ms
- Robust Features and Performance for Industrial Environments
  - Multibit CRC Code Generation and Transmission for Error Detection and More Reliable Data Transmission
  - High ESD Immunity on All Field Input Pins
- Accepts Industry Standard Input Types
  - Configurable for IEC 61131-2 Input Types 1, 2, and 3
- Flexible Power Supply Capability Enables Usage in 5V, 12V, 24V, and Higher Voltage Systems
  - Wide Operating Field Supply Range of 7V to 36V
  - Can Be Powered from the Logic-Side Using a 5V Supply

### Applications

- Digital Input Modules for PLCs
- Industrial, Building, and Process Automation
- Motor Control

[Ordering Information](#) appears at end of data sheet.

# MAX31912

# Ultra-Low Power Industrial, Octal, Digital Input Translator/Serializer

## Block Diagram

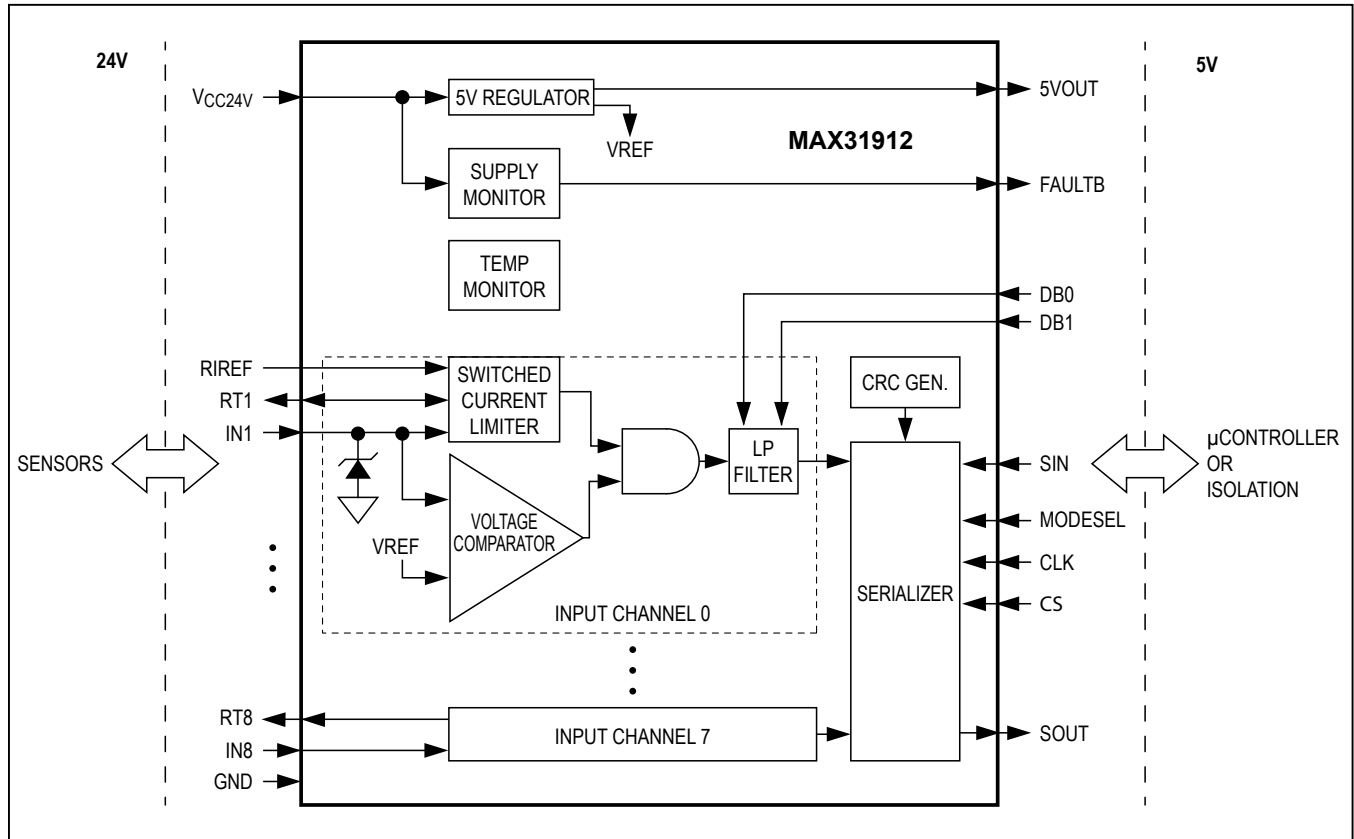

**Absolute Maximum Ratings**

(Voltages relative to GND.)  
 Voltage Range on V<sub>CC24V</sub> .....-0.3V to +45V  
 Voltage Range on IN1–IN8 .....-0.3V to +45V  
 Voltage Range on IN1–IN8  
 (through 2.2kΩ resistors) .....-45V to +45V  
 Voltage Range on DB0/DB1, CLK, SIN,  
 CS, MODESEL ..... -0.3V to (V<sub>5VOUT</sub> + 0.3V)  
 Continuous Power Dissipation (T<sub>A</sub> = +70°C)  
 TSSOP (derate 27mW/°C above +70°C) .....2162.2mW

Operating Temperature Range  
 Ambient Temperature ..... -40°C to +125°C  
 Junction Temperature ..... -40°C to +150°C  
 Storage Temperature Range ..... -55°C to +125°C  
 Lead Temperature (soldering, 10s) ..... +300°C  
 Soldering Temperature (reflow) ..... +260°C

*Stresses beyond those listed under "Absolute Maximum Ratings" may cause permanent damage to the device. These are stress ratings only, and functional operation of the device at these or any other conditions beyond those indicated in the operational sections of the specifications is not implied. Exposure to absolute maximum rating conditions for extended periods may affect device reliability.*

**Package Thermal Characteristics (Note 1)**

TSSOP  
 Junction-to-Ambient Thermal Resistance (θ<sub>JA</sub>) .....37°C/W      Junction-to-Case Thermal Resistance (θ<sub>JC</sub>) .....2°C/W

**Note 1:** Package thermal resistances were obtained using the method described in JEDEC specification JESD51-7, using a four-layer board. For detailed information on package thermal considerations, refer to [www.maximintegrated.com/thermal-tutorial](http://www.maximintegrated.com/thermal-tutorial).

**Recommended Operating Conditions (Note 2)**

| PARAMETER                      | SYMBOL             | CONDITIONS | MIN  | TYP | MAX | UNITS |
|--------------------------------|--------------------|------------|------|-----|-----|-------|
| Field Supply Voltage           | V <sub>CC24V</sub> | (Note 3)   | 7    |     | 36  | V     |
| Field Inputs Voltage           | V <sub>INn</sub>   | (Note 4)   | -0.3 |     | 36  | V     |
| Logic Inputs Voltage           | V <sub>LOGIC</sub> |            | 0    |     | 5.5 | V     |
| Current-Limit Setting Resistor | R <sub>REF</sub>   |            |      | 15  |     | kΩ    |
| Field Input Data Rate          | f <sub>IN</sub>    | (Note 5)   |      | 200 |     | kHz   |

## DC Electrical Characteristics

(V<sub>CC24V</sub> = 7V to 36V, T<sub>J</sub> = -40°C to +150°C, unless otherwise noted.) (Note 2)

| PARAMETER                                  | SYMBOL                | CONDITIONS   | MIN                        | TYP                        | MAX                        | UNITS |
|--|-----------------------|--|----------------------------|----------------------------|----------------------------|-------|
| Field-Supply Current                       | I <sub>CC24V</sub>    | IN1–IN8 = 24V, 5VOUT = open,<br>RT1–RT8 = GND, all logic inputs open                                   |                            | 1.6                        | 2.3                        | mA    |
| Field-Supply UV1 Alarm Off/On              | V <sub>ONUV1</sub>    |  |                            | 9                          | 10                         | V     |
| Field-Supply UV1 Alarm On/Off              | V <sub>OFFUV1</sub>   |  | 7                          | 8                          |                            | V     |
| Field-Supply UV2 Alarm Off/On              | V <sub>ONUV2</sub>    |  |                            | 16.5                       | 18                         | V     |
| Field-Supply UV2 Alarm On/Off              | V <sub>OFFUV2</sub>   |  | 14                         | 15.5                       |                            | V     |
| LED On-State Current                       | I <sub>RT-ON</sub>    | R <sub>REF</sub> = 15kΩ, V <sub>CC24V</sub> = 18V to 30V   |                            | 2.2                        |                            | mA    |
| Field Input Threshold High-to-Low          | V <sub>IN-(INF)</sub> | 2.2kΩ external series resistor   | 7                          | 8.4                        |                            | V     |
| Field Input Threshold Low-to-High          | V <sub>IN+(INF)</sub> | 2.2kΩ external series resistor<br>(Note 12)  |                            | 9.4                        | 10.2                       | V     |
| Field Input Hysteresis                     | V <sub>HYS(INF)</sub> | 2.2kΩ external series resistor<br>(Note 12)  |                            | 1                          |                            | V     |
| Input Threshold High-to-Low<br>(at IC pin) | V <sub>TH-(INP)</sub> |  | 3                          | 3.4                        |                            | V     |
| Input Threshold Low-to-High<br>(at IC pin) | V <sub>TH+(INP)</sub> | (Note 12)  |                            | 4.4                        | 5                          | V     |
| Input Threshold Hysteresis<br>(at IC pin)  | V <sub>HYS(INP)</sub> | (Note 12)  |                            | 1                          |                            | V     |
| Field Input Pin Resistance                 | R <sub>INP</sub>      |  |                            | 0.8                        |                            | kΩ    |
| Field Input Current Limit                  | I <sub>INLIM</sub>    | R <sub>REF</sub> = 15kΩ, V <sub>CC24V</sub> = 18V to 30V,<br>T <sub>A</sub> = +25°C to +125°C (Note 6) | 2.2                        | 2.4                        | 2.7                        | mA    |
| Filter Time Constant                       | t <sub>FILTER</sub>   | DB1/DB0 = 0/0: no filtering  |                            | 0                          |                            | ms    |
|  |                       | DB1/DB0 = 0/1  | 0.008                      | 0.025                      | 0.038                      |       |
|  |                       | DB1/DB0 = 1/0  | 0.25                       | 0.75                       | 1.1                        |       |
|  |                       | DB1/DB0 = 1/1  | 1.0                        | 3                          | 4.5                        |       |
| Linear Regulator Output                    | V <sub>5VOUT</sub>    | Max I <sub>LOAD</sub> = 50mA   | 4.75                       | 5.0                        | 5.25                       | V     |
| Regulator Line Regulation                  | dV <sub>REGLINE</sub> | I <sub>LOAD</sub> = 50mA   |                            | 10                         |                            | mV    |
| Regulator Load Regulation                  | dV <sub>REGLOAD</sub> | I <sub>LOAD</sub> = 1mA to 50mA  |                            | 20                         |                            | mV    |
| Logic-Low Output Voltage                   | V <sub>OL</sub>       | I <sub>OL</sub> = 4mA  |                            | 0.4                        | 1.0                        | V     |
| Logic-High Output Voltage                  | V <sub>OH</sub>       | I <sub>OH</sub> = -4mA   | 4.0                        |                            |                            | V     |
| Logic-Input Trip Point                     | V <sub>IH-IL</sub>    |  | 0.3x<br>V <sub>5VOUT</sub> | 0.5x<br>V <sub>5VOUT</sub> | 0.7x<br>V <sub>5VOUT</sub> | V     |
| Logic-Input Leakage Current                | I <sub>IL</sub>       |  | -50                        | -30                        | -15                        | μA    |
| Overtemperature Alarm                      | T <sub>ALRM</sub>     |  |                            | 135                        |                            | °C    |

## AC Electrical Characteristics

( $V_{CC24V} = 7V$  to  $36V$ ,  $T_J = -40^{\circ}C$  to  $+150^{\circ}C$ , unless otherwise noted.) (Note 2)

| PARAMETER               | SYMBOL   | CONDITIONS                             | MIN | TYP      | MAX | UNITS   |
|-------------------------|----------|--|-----|----------|-----|---------|
| Field Input Pulse Width | $t_{PW}$ | No external capacitors on pins IN1–IN8 | 1   |          |     | $\mu s$ |
| ESD                     |          | HBM, all pins                          |     | $\pm 2$  |     | kV      |
|                         |          | HBM, IN1–IN8 with respect to GND       |     | $\pm 15$ |     |         |

## AC Electrical Characteristics: SPI Interface

( $V_{CC24V} = 7V$  to  $36V$ ,  $T_J = -40^{\circ}C$  to  $+150^{\circ}C$ , unless otherwise noted.) (Note 2)

| PARAMETER                                  | SYMBOL      | CONDITIONS    | MIN | TYP | MAX | UNITS |
|--|-------------|---------------|-----|-----|-----|-------|
| CLK Pulse Duration                         | $t_{CLKPW}$ | (Note 7)      | 20  |     |     | ns    |
| $\overline{CS}$ Pulse Duration             | $t_{CSPW}$  | (Note 8)      | 20  |     |     | ns    |
| SIN to CLK Setup Time                      | $t_{SU1}$   | (Note 9)      | 5   |     |     | ns    |
| SIN to CLK Hold Time                       | $t_{H1}$    | (Note 9)      | 8   |     |     | ns    |
| $\overline{CS}$ to CLK Setup Time          | $t_{SU2}$   | (Note 10)     | 8   |     |     | ns    |
| $\overline{CS}$ to CLK Recovery Time       | $t_{REC}$   | (Note 10)     | 12  |     |     | ns    |
| Clock Pulse Frequency                      | $f_{CLK}$   | (Notes 7, 11) |     |     | 25  | MHz   |
| Propagation Delay, CLK to SOUT             | $t_{P1}$    | (Note 7)      |     |     | 20  | ns    |
| Propagation Delay, $\overline{CS}$ to SOUT | $t_{P2}$    | (Note 8)      |     |     | 20  | ns    |
| Rise/Fall Time SOUT/ $\overline{FAULT}$    | $t_{R/F}$   | (Note 7)      |     |     | 40  | ns    |

**Note 2:** Limits are 100% production tested at  $T_A = +25^{\circ}C$  and  $T_A = +125^{\circ}C$ . Limits over the operating temperature range and relevant supply voltage range are guaranteed by design and characterization. Typical values are not guaranteed.

**Note 3:** If a 24V supply is not available, the device can be powered through  $V_{5VOUT}$ . In this mode of operation, the  $V_{CC24V}$  supply must be left unconnected. All other specifications remain identical. The field-supply UV1 and UV2 alarms will be activated (set to 1), indicating the absence of the 24V supply in this mode of operation.

**Note 4:** When using suggested external 2.2k $\Omega$  series resistors, limits of -3V to +36V apply.

**Note 5:**  $f_{IN}$  refers to the maximum pulse frequency ( $1/f_{IN} =$  shortest pulse width) that can be detected from the field sensors and switches.

**Note 6:** External resistor  $R_{REF}$  can be adjusted to set any desired current limit between 0.5mA and 6mA.

**Note 7:** See Figure 9.

**Note 8:** See Figure 6.

**Note 9:** See Figure 8.

**Note 10:** See Figure 7.

**Note 11:** This is the maximum bit transfer rate through the serializer interface.

**Note 12:** When input current switching is enabled (DB0/DB1  $\neq$  00), there is no Input Threshold Hysteresis. In this case, the Input Threshold for both falling and rising signal is the High-to-Low Threshold.

Typical Operating Characteristics

( $T_A = +25^\circ\text{C}$ ,  $R_{REF} = 15\text{k}\Omega$ , unless otherwise noted.)

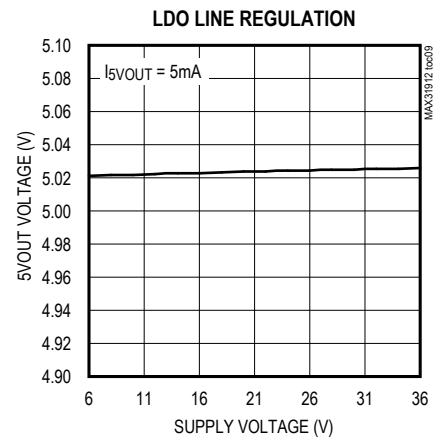
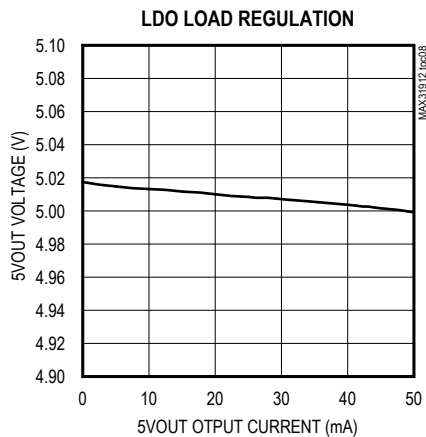
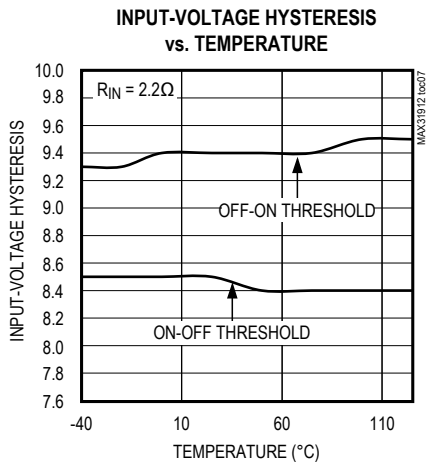
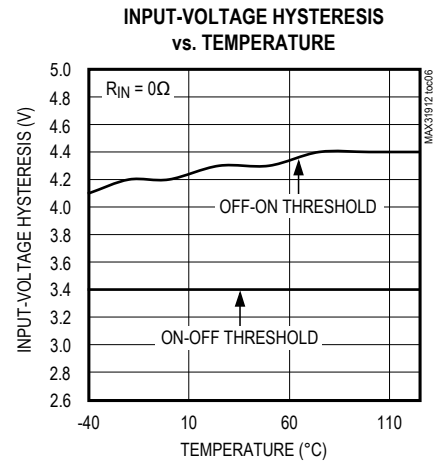
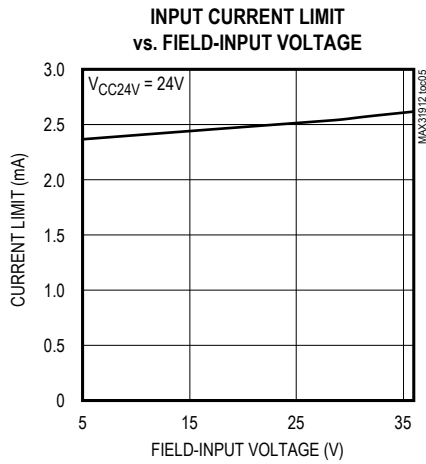
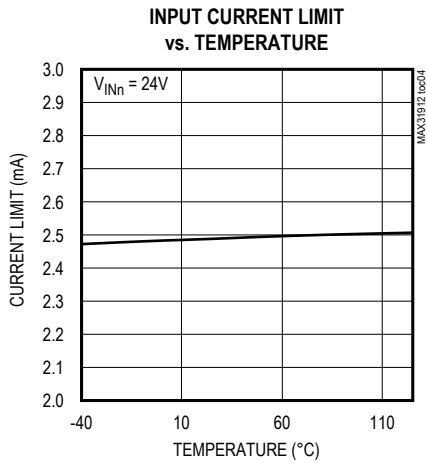
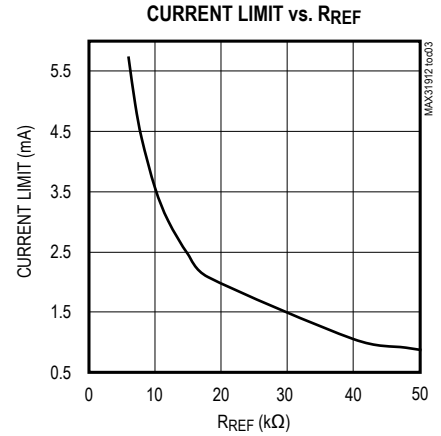
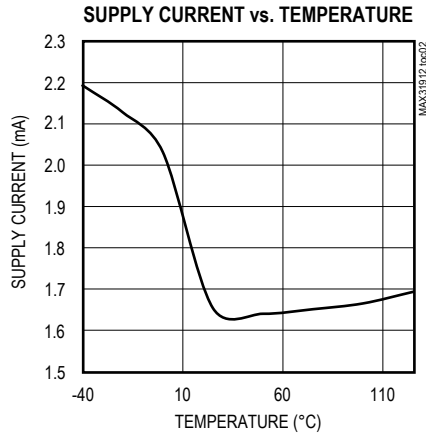
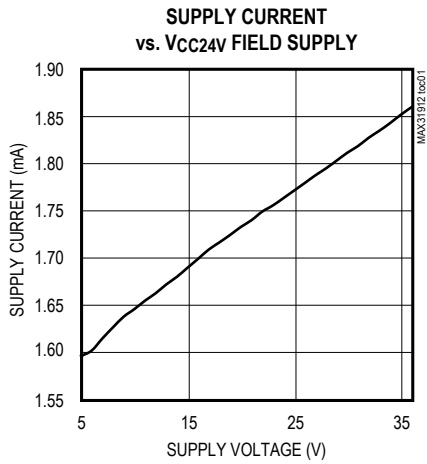

Typical Operating Characteristics (continued)

( $T_A = +25^\circ\text{C}$ ,  $R_{REF} = 15\text{k}\Omega$ , unless otherwise noted.)

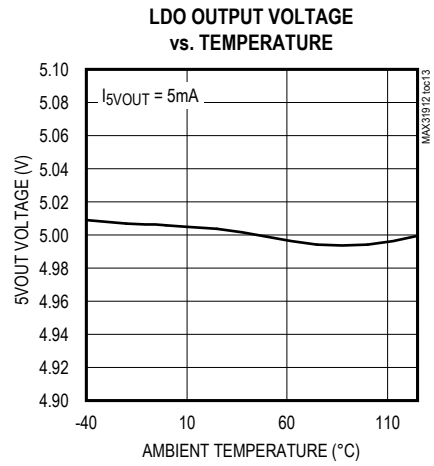
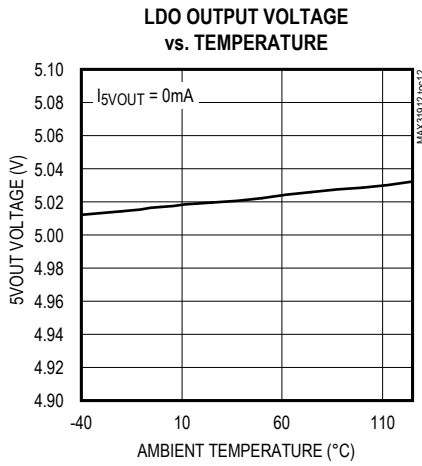
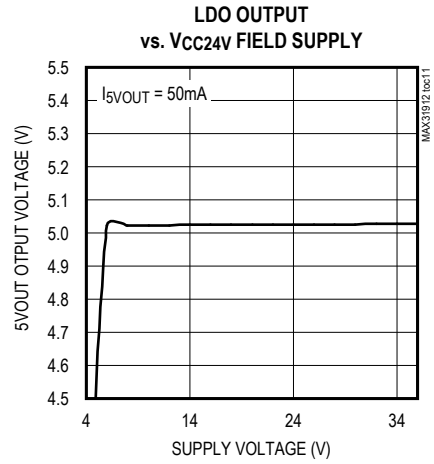
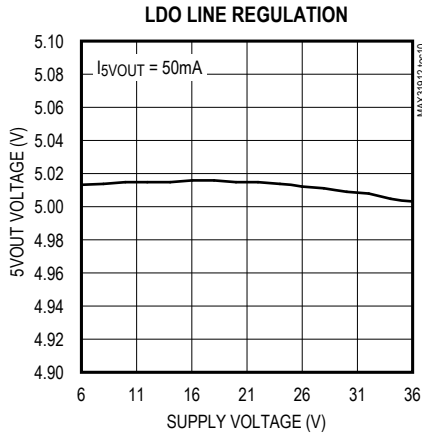

Pin Configuration

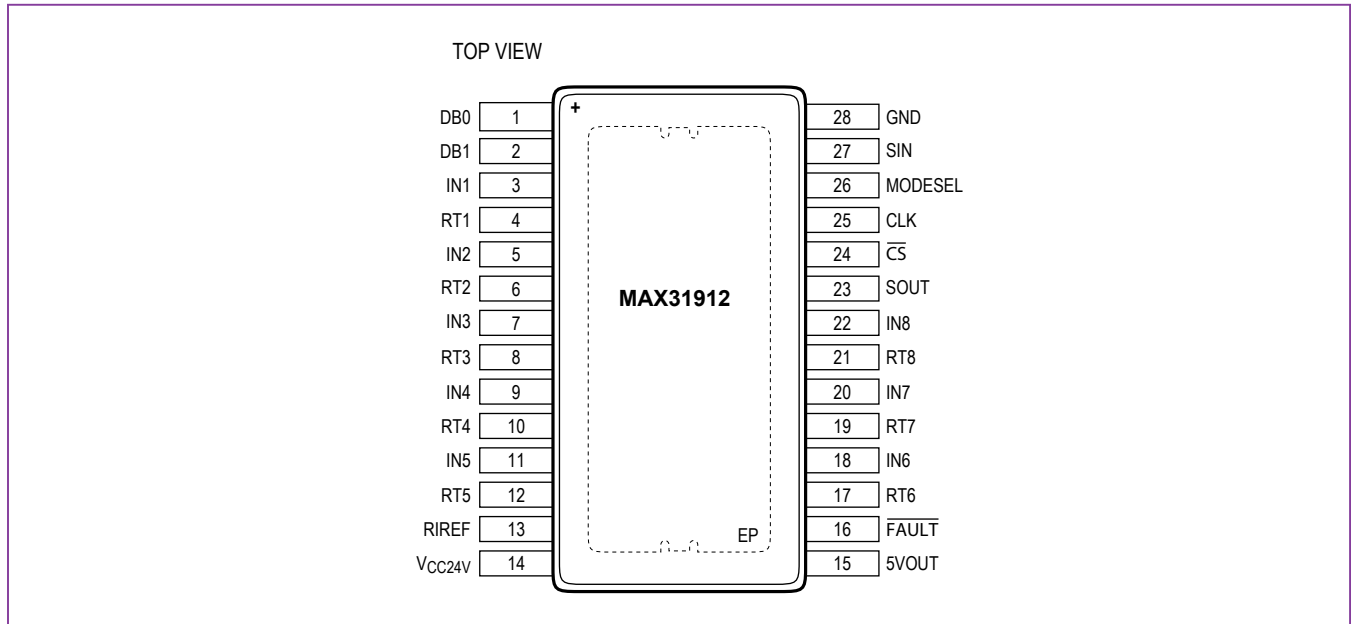

Pin Description

| PIN                         | NAME               | FUNCTION  |
|-----------------------------|--------------------|---|
| 1, 2                        | DB0, DB1           | Debounce (Filtering) Time Select Inputs. These inputs also determine the current switching frequency. See also Table 1 for details. |
| 3, 5, 7, 9, 11, 18, 20, 22  | IN1–IN8            | Field Inputs  |
| 4, 6, 8, 10, 12, 17, 19, 21 | RT1–RT8            | Energyless LED Driver Outputs. Connect to GND if LEDs are not required.   |
| 13                          | RIREF              | Current-Limiter Reference Resistor  |
| 14                          | V <sub>CC24V</sub> | Field-Supply Voltage  |
| 15                          | 5VOUT              | 5V Regulator Output   |
| 16                          | $\overline{FAULT}$ | Active-Low Undervoltage Alarm   |
| 23                          | SOUT               | Serial-Data Out   |
| 24                          | $\overline{CS}$    | Active-Low Chip-Select Input  |
| 25                          | CLK                | Serial-Clock Input  |
| 26                          | MODESEL            | Mode-Select Input<br>MODESEL = 1: Selects 8-bit shift register<br>MODESEL = 0: Selects 16-bit shift register                        |
| 27                          | SIN                | Serial-Data Input   |
| 28                          | GND                | Field Ground  |
| —                           | EP                 | Exposed Pad. Must be connected to the PCB ground plane.   |

Basic Application Circuit

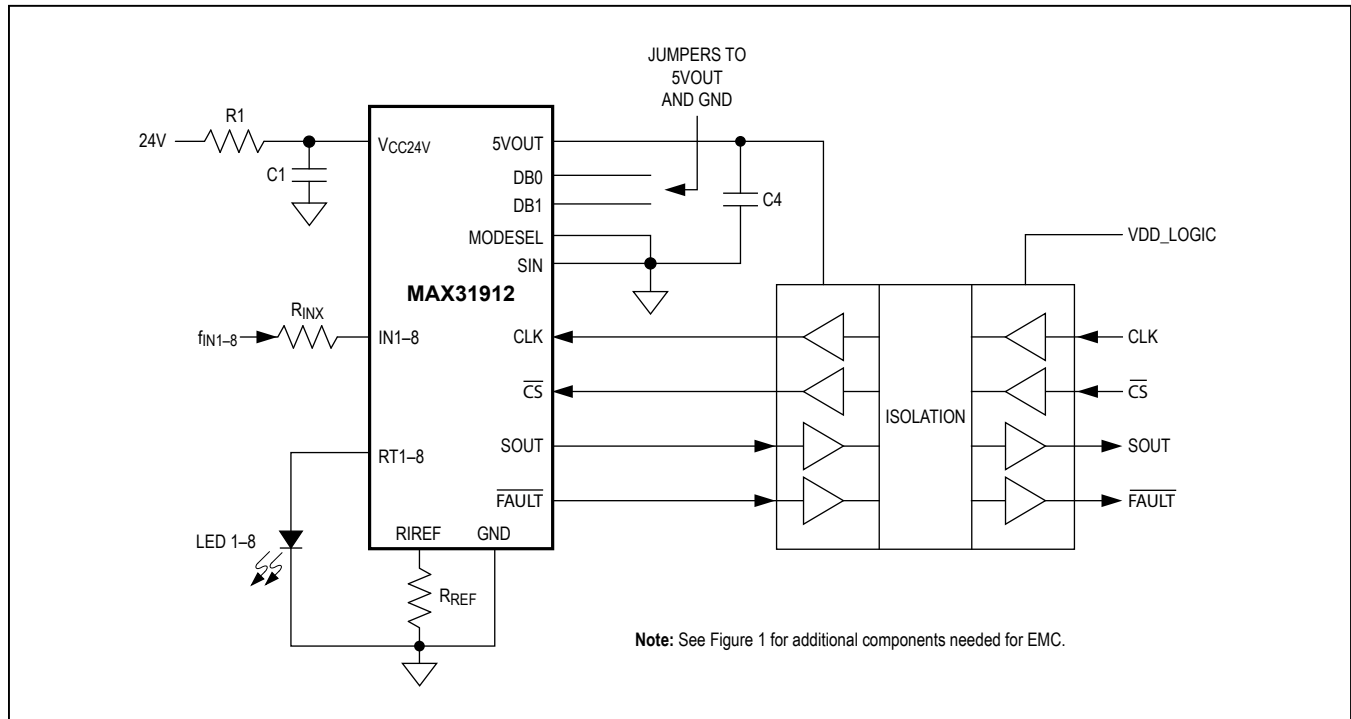

Detailed Description

Input Current Clamp

The MAX31912 industrial interface serializer inputs (IN1–IN8) sense the state (on vs. off) of field sensors by monitoring both voltage and current flowing through the sensor output. The current sinking through these input pins rises linearly with input voltage until the limit set by the current clamp is reached. Any voltage increase beyond this point does not increase the input current any further.

The value of the current clamp is adjustable through an external resistor connected between the RIREF pin and GND. Pins RT1–RT8 are connected through LEDs that recycle the current from the eight inputs to provide visual status indication without consuming additional current. If LEDs are not used, these pins must be connected directly to GND to provide a return path for the input current. The voltage and current at the IN1–IN8 input pins are compared against internally set references to determine whether the sensor is on (logic 1) or off (logic 0). The trip points determining the on/off status of the sensor satisfy the requirements of IEC 61131-2 Type 1 and 3 switches. The device can also be configured to work as a Type 2 switch.

Glitch Filter

A digital glitch filter provides debouncing and filtering of noisy sensor signals. The time constant of this filter is programmable from 0ms to 3ms through the DB0 and DB1 pins. See [Table 1](#) for debounce settings.

To provide the digital glitch filter, the device checks that an input is stable for at least three clock cycles. The duration of a clock cycle is 1/3 of the selected debounce time. If the input is not stable for at least three clock cycles, the input change is not sent to the internal shift register. See [Table 1](#) for current switching settings.

Low-Power Current Clamp Switching

The MAX31912 uses a patent-pending switched current limiter to reduce power consumption below what is achievable by current limiting alone. The internal filter clock is used to switch input current between 100% and 20% of the chosen current limit. For example, if the current limit is set to 2.4mA, the input current will switch between 2.4mA and 0.48mA. The filter clock switches input current at a 50% duty cycle. The clock period for current switching is automatically selected by the DB1 and DB0 glitch filter settings. See [Table 1](#) for current switching settings.

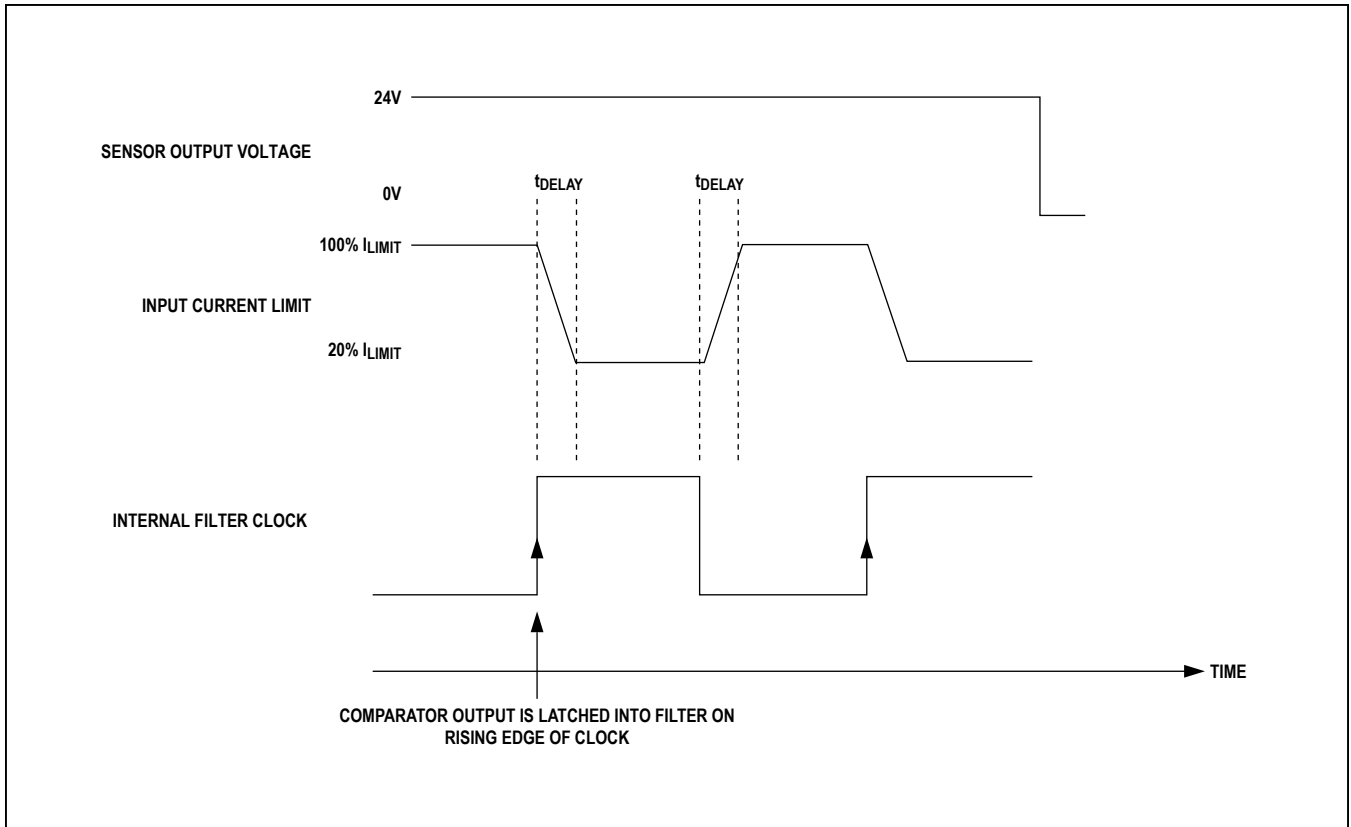

Figure 1. Operation of Patent-Pending Switched Current Limiter

Table 1. Debounce/Current Switching Period Settings

| DB1 | DB0 | BINARY VALUE | DEBOUNCE TIME | CURRENT SWITCHING PERIOD |
|-----|-----|--------------|---------------|--------------------------|
| 0   | 0   | 0            | 0             | DC (disabled)            |
| 0   | 1   | 1            | 25 $\mu$ s    | 8 $\mu$ s                |
| 1   | 0   | 2            | 0.75ms        | 0.25ms                   |
| 1   | 1   | 3            | 3ms           | 1ms                      |

### Reading Serial Data

The filtered outputs of the input comparators are latched into a shift register at the falling edge of  $\overline{CS}$ . Clocking the CLK pin, while  $\overline{CS}$  is held low, shifts the latched data out of SOUT 1 bit at a time.

The internal data serializer comprises a 16-bit shift register, containing 8 bits of data corresponding to the eight field inputs, as well as an 8-bit status byte containing supplementary status and CRC information. The status byte contains 1 bit representing the status of the field-supply voltage (UV1), 1 bit representing the status of the internal temperature monitor (OT), a 5-bit CRC code internally calculated and generated, 1 bit representing a secondary voltage supply monitor (UV2).

The undervoltage (UV1) bit is normally 1. If the supply voltage falls below  $V_{OFFUV1}$ , the UV1 becomes a 0. The UV1 bit returns to 1 once the supply voltage has returned above  $V_{ONUV1}$ .

The overtemperature (OT) bit is normally 0. If the junction temperature increases to above  $T_{ALRM}$ , the OT bit becomes a 1. The bit returns to 0 once the junction temperature has returned below  $T_{ALRM}$ .

The CRC code can be used to check data integrity during transfer from the device to an external microcontroller. In applications where the integrity of data transferred is not of concern, the CRC bits can be ignored. The CRC uses the following polynomial:

$$P(x) = x^5 + x^4 + x^2 + x^0$$

The number of bits in the internal serializer can be selected between 8 bits or 16 bits. The MODESEL pin is used to configure the serializer as an 8-bit (disabling the status byte) or 16-bit shift register. In 8-bit mode, only the eight field input states are transferred through the SPI port and the status byte is ignored. Therefore, in multiple IC applications (input channels greater than 8), if desired, only a single status byte can be generated and transmitted for any number of input channels.

The shift register contents are read only (no write capability exists) through the SPI-compatible interface.

For higher input counts than 8, multiple devices can be cascaded. In this case, the SOUT pin of one device should be connected to the SIN pin of the next device, effectively cascading the internal shift registers. The CLK and  $\overline{CS}$  pins of all the devices should be connected together in this configuration. See the [Serial-Port Operation](#) section for more detailed information on operating the SPI interface.

### Temperature Monitoring

The internal junction temperature of the device is constantly monitored. An alarm is raised, by asserting the OT bit to a 1.

### Supply Voltage Monitoring

A primary supply voltage monitor circuit constantly monitors the field-supply voltage. If this voltage falls below a threshold ( $V_{OFFUV1}$ ), an alarm is raised by asserting the  $\overline{FAULT}$  pin, indicating that the part is experiencing a fault condition and the data in the serializer is not to be trusted. In addition, the device resets the UV1 bit to a 0. Once the field-supply voltage has recovered and goes above  $V_{ONUV1}$ , the  $\overline{FAULT}$  pin is released. A secondary supply voltage monitor circuit also monitors the field-supply voltage. This secondary monitor only raises a flag in the serializer, by resetting the UV2 bit to 0 (it does not assert the  $\overline{FAULT}$  pin), if the field supply drops below  $V_{OFFUV2}$ . Once the supply voltage goes back above  $V_{ONUV2}$ , the UV2 bit is set to 1. The secondary supply monitor has higher trip points and its purpose is to warn the system that the supply voltage is below specifications (approximately 24V - 20%). Whereas the purpose of the primary supply monitor is to warn that the supply voltage has dropped to a value close to the minimum operating voltage of the IC.

Applications Information

EMC Standards Compliance

The external components shown in Figure 1 allow the device to operate in harsh industrial environments. Components were chosen to assist in suppression of voltage burst and surge transients, allowing the system

to meet or exceed international EMC requirements. Table 2 lists an example device for each component in Figure 2. The system shown in Figure 2, using the components shown in Table 2, is designed to be robust against IEC fast transient burst, surge, conducted RFI specifications and ESD specifications (IEC 61000-4-4, -5, -6, and -2).

Table 2. Recommended Components

| COMPONENT        | DESCRIPTION                             | REQUIRED/RECOMMENDED/OPTIONAL              |
|------------------|---|--|
| C0               | 4.7nF, 2kV polypropylene capacitor      | Recommended                                |
| C1               | 10µF, 60V ceramic capacitor             | Required                                   |
| C3               | 100nF, 10V ceramic capacitor            | Recommended                                |
| C4               | 4.7µF, 10V low ESR ceramic capacitor    | Required                                   |
| C5               | 100nF, 100V ceramic capacitor           | Recommended                                |
| D0               | 36V fast zener diode (ZSMB36)           | Recommended                                |
| D1               | General-purpose rectifier (IN4007)      | Optional: For reverse-polarity protection. |
| LED1–LED8        | LEDs for visual input status indication | Optional                                   |
| R1               | 150Ω, 1/3W MELF resistor                | Required                                   |
| R <sub>INX</sub> | 2.2kΩ, 1/4W MELF resistor               | Required                                   |
| R <sub>REF</sub> | 15kΩ, 1/8W resistor                     | Required                                   |

**Note:** For higher EFT performance, a minimum 1nF, 1000V capacitor can be added from nodes  $f_{IN1-8}$  to Earth or Ground. For additional methods to improve EFT robustness, please check the Maxim website regularly for upcoming application notes currently being developed.

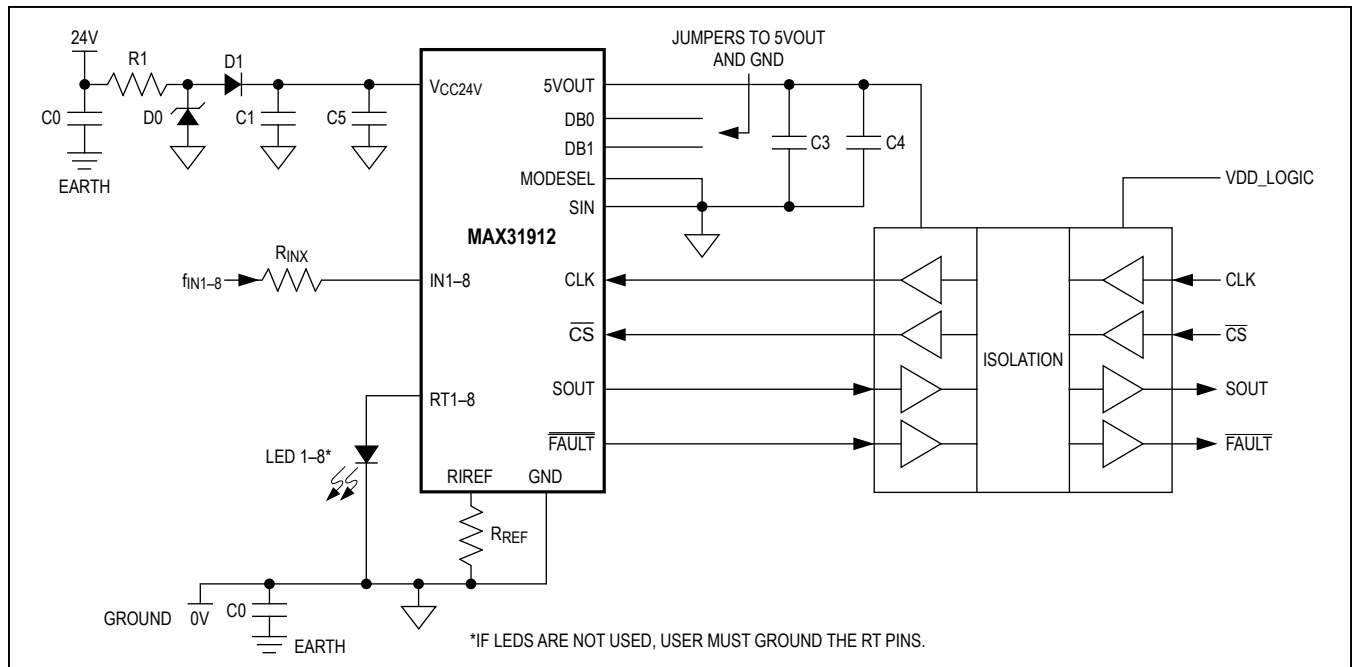

Figure 2. Typical EMC Protection Circuitry

### Serial-Port Operation

Serial output of the device functions in one of two modes, depending on the MODESEL setting (Table 3). With MODESEL = 0, the device output includes a 5-bit CRC, an undervoltage alarm, and an overtemperature alarm. See the [Detailed Description](#) for CRC, undervoltage, and overtemperature functional descriptions. With MODESEL = 1, the device outputs only the state of the IN1–IN8 inputs and omits the CRC, undervoltage alarm, and overtemperature alarm.

### Daisy-Chain Operation

For systems with more than eight sensor inputs, multiple devices can be daisy-chained to allow access to all data inputs through a single serial port. When using a daisy-chain configuration, connect SOUT of one of the devices to the SIN input of another upstream device.  $\overline{CS}$  and SCK of all devices in the chain should be connected together

in parallel (see Figure 3). In a daisy-chain configuration, external components used to enhance EMC robustness do not need to be duplicated for each device of a circuit board. Figure 5 illustrates a 16-input application.

### SPI Waveforms

The serial output of the device adheres to the SPI protocol, running with CPHA = 0 and CPOL = 0. Input states on IN1–IN8 are latched in on the falling edge of  $\overline{CS}$ . The transfer of data out of the slave output, SOUT, starts immediately when  $\overline{CS}$  is asserted (i.e., MSB is output onto SOUT independent of CLK). The remaining data bits are shifted out on the falling edge of CLK. The data bits are written to the output SOUT with MSB first. When  $\overline{CS}$  is high, SOUT is high impedance. The resultant timing is shown in Figure 6. Note that all bits after IN1 are invalid if 8-bit operation mode is selected with the MODESEL input. Figure 7, Figure 8, Figure 9, and Figure 10 illustrate SPI timing specifications.

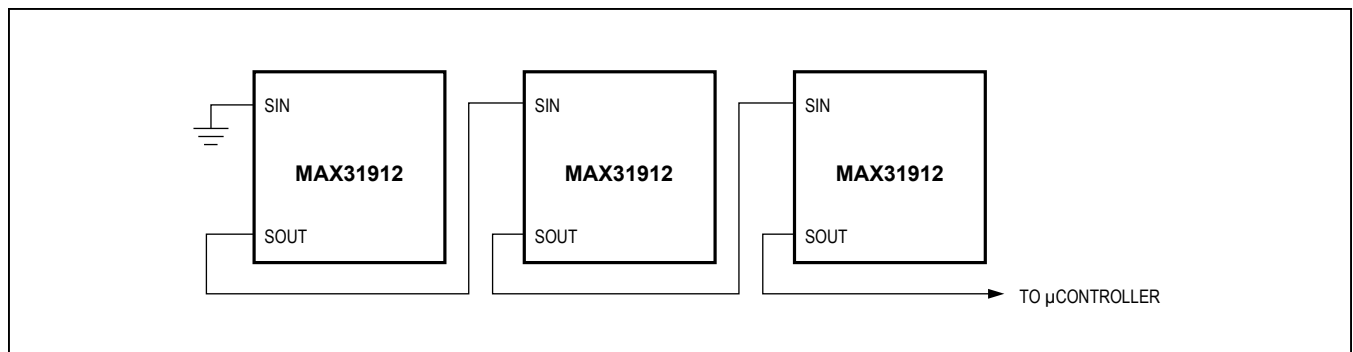

Figure 3. Daisy-Chain Operation

Table 3. MODESEL Settings

| MODESEL SETTING | FUNCTIONALITY                                       |
|-----------------|---|
| 0               | 16-bit output; [IN8–IN1][CRC (5 bit)][UV1][OT][UV2] |
| 1               | 8-bit output; [IN8–IN1]                             |

**Powering the Device Through the 5VOUT Pin**

The device can alternatively be powered using a 5V supply connected to the 5VOUT pin. In this case a 24V supply is no longer needed and the VCC24V supply must be kept unconnected. (see [Figure 4](#))

In this configuration, the device will always indicate a UVFAULT (UV1 and UV2) and the FAULT pin will always be active (pulled low). Faults due to the Supply Voltage monitoring will not be available. Faults due to the Temperature monitor can only be read through the SPI interface.

This configuration has lower power consumption and heat dissipation since the on-chip 5V voltage regulator is disabled.

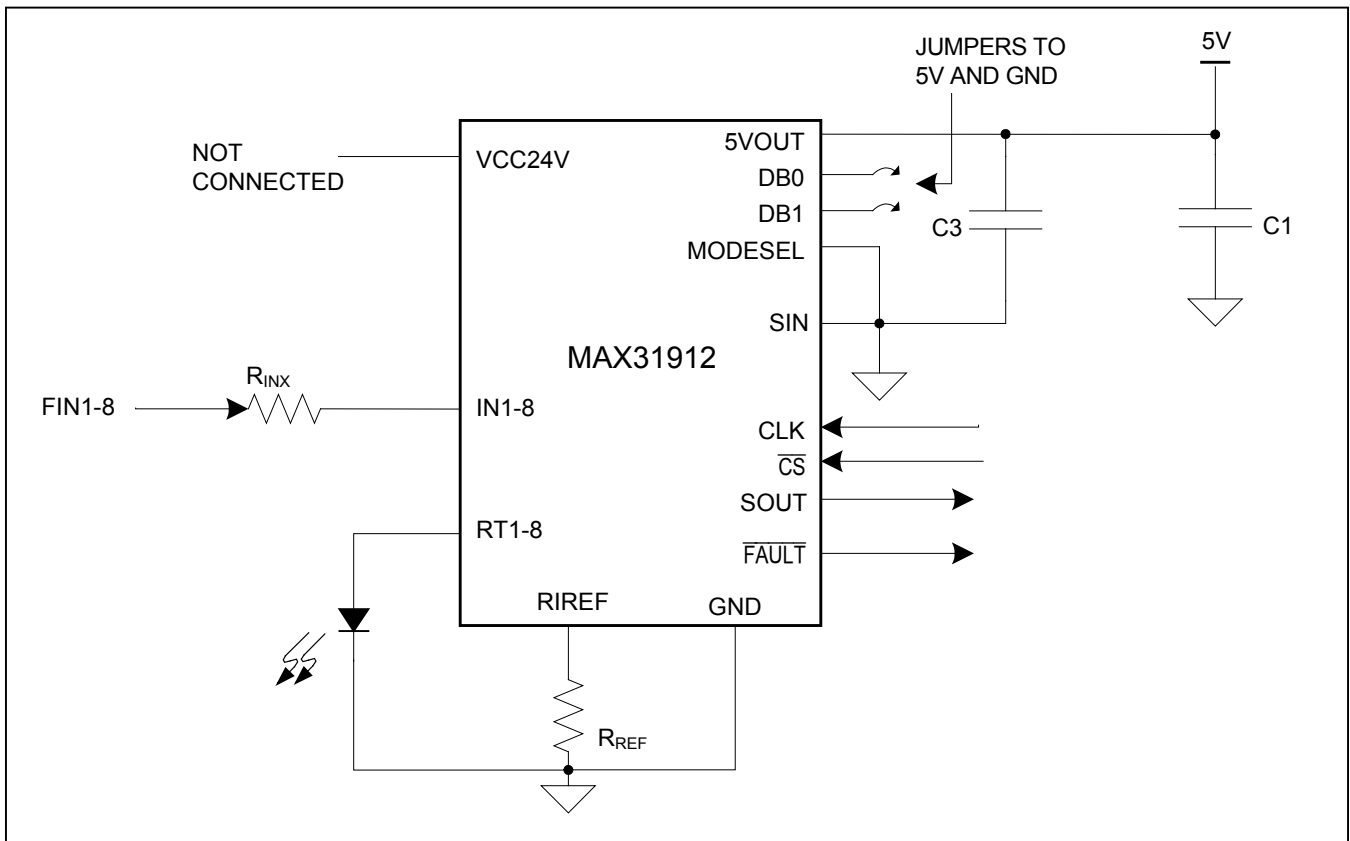

Figure 4. Basic Application Powered Through 5VOUT

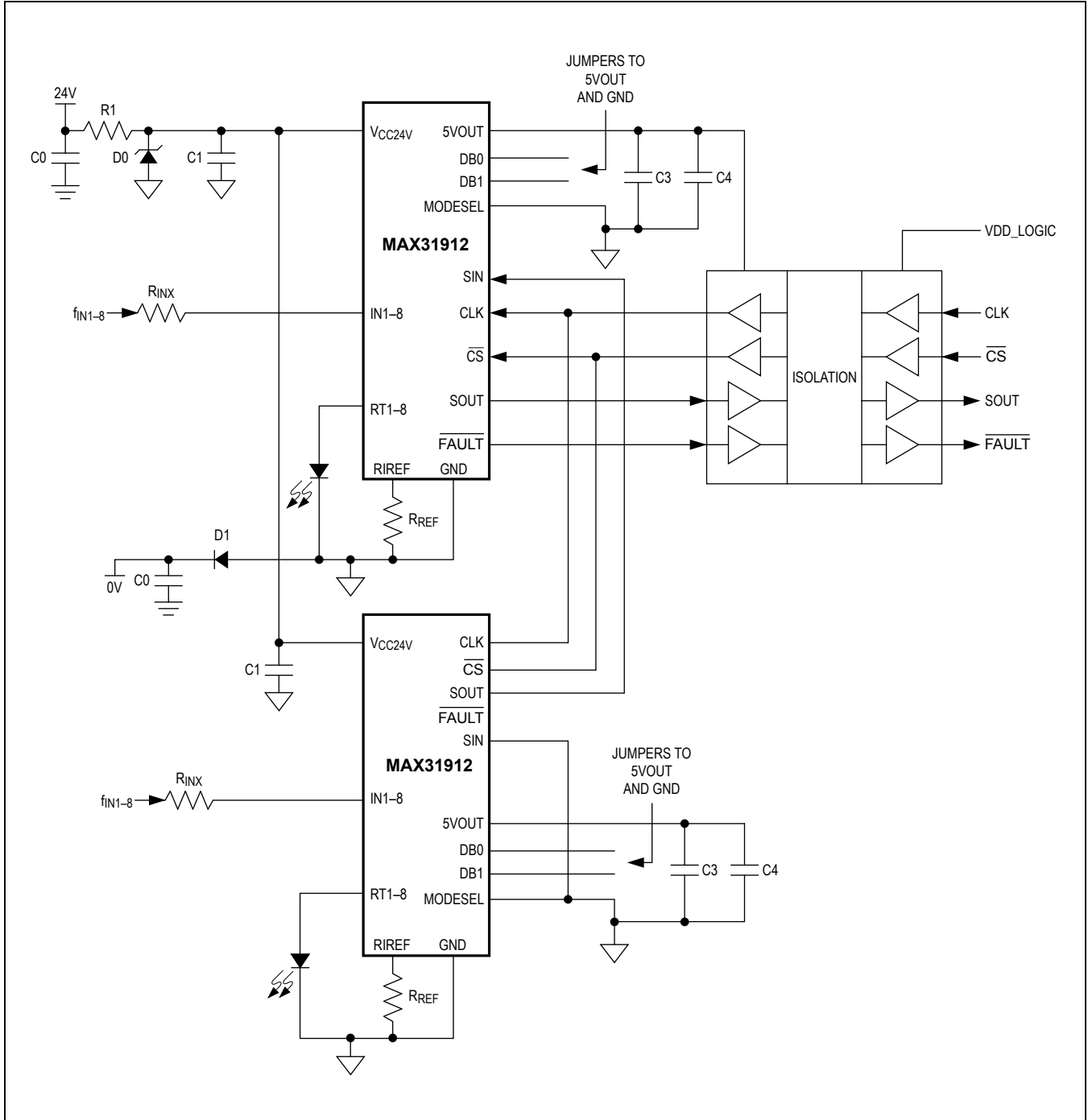

Figure 5. 16-Input Application Circuit

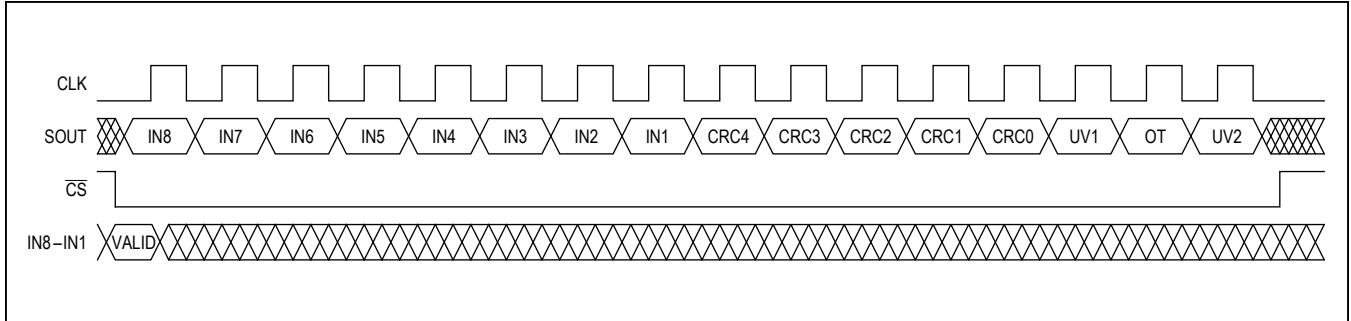

Figure 6. SPI Communication Example

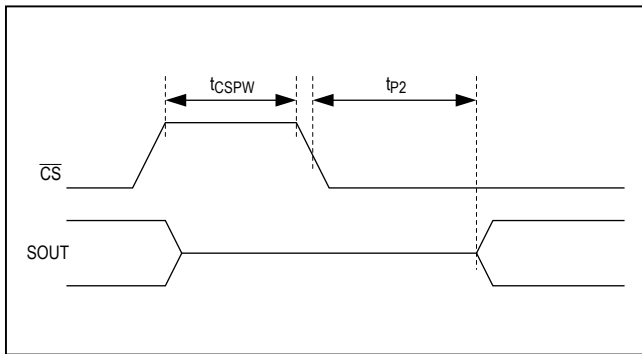

Figure 7. SPI Timing Diagram 1

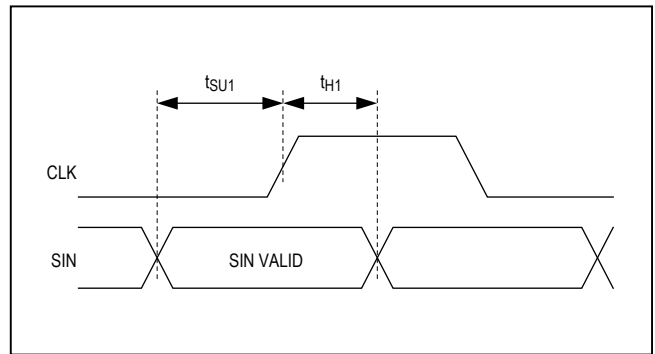

Figure 9. SPI Timing Diagram 3

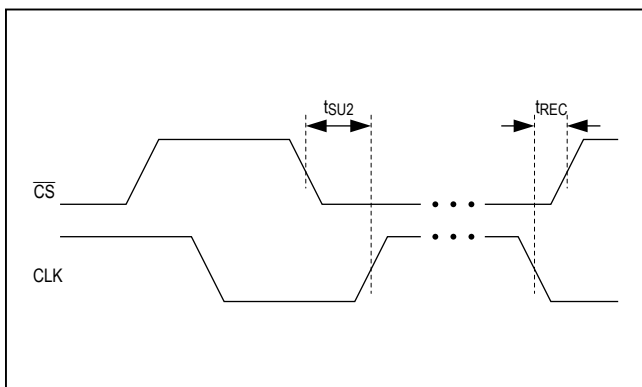

Figure 8. SPI Timing Diagram 2

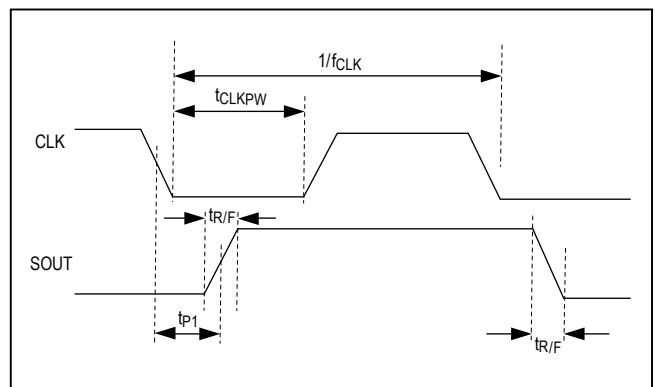

Figure 10. SPI Timing Diagram 4

## Ordering Information

| PART          | TEMP RANGE      | PIN-PACKAGE | CARRIER       |
|---------------|-----------------|-------------|---------------|
| MAX31912AUI+  | -40°C to +125°C | 28 TSSOP    | Bulk          |
| MAX31912AUI+T | -40°C to +125°C | 28 TSSOP    | Tape and Reel |

+Denotes a lead(Pb)-free/RoHS-compliant package.

T = Tape and reel.

## Chip Information

PROCESS: S45JRS

## Package Information

For the latest package outline information and land patterns (footprints), go to [www.maximintegrated.com/packages](http://www.maximintegrated.com/packages). Note that a "+", "#", or "-" in the package code indicates RoHS status only. Package drawings may show a different suffix character, but the drawing pertains to the package regardless of RoHS status.

| PACKAGE TYPE | PACKAGE CODE | OUTLINE NO.             | LAND PATTERN NO.        |
|--------------|--------------|-------------------------|-------------------------|
| 28 TSSOP-EP  | U28E+4       | <a href="#">21-0108</a> | <a href="#">90-0146</a> |

## Revision History

| REVISION NUMBER | REVISION DATE | DESCRIPTION   | PAGES CHANGED |
|-----------------|---------------|---|---------------|
| 0               | 3/14          | Initial release   | —             |
| 1               | 7/14          | Updated <i>Input Current Clamp</i> section  | 8             |
| 2               | 2/15          | Updated page 1 content  | 1             |
| 3               | 4/15          | Updated <i>Reading Serial Data</i> section, IEC diagram, and added <i>Powering the Device Through the 5VOUT Pin</i> section | 11-13, 15     |

For pricing, delivery, and ordering information, please contact Maxim Direct at 1-888-629-4642, or visit Maxim Integrated's website at [www.maximintegrated.com](http://www.maximintegrated.com).

Maxim Integrated cannot assume responsibility for use of any circuitry other than circuitry entirely embodied in a Maxim Integrated product. No circuit patent licenses are implied. Maxim Integrated reserves the right to change the circuitry and specifications without notice at any time. The parametric values (min and max limits) shown in the Electrical Characteristics table are guaranteed. Other parametric values quoted in this data sheet are provided for guidance.

## Looking for pricing, stock, or lifecycle information?

Click below to explore more details on WIN SOURCE:

- ⊖ [View MAX31912EVKIT# on WIN SOURCE](#)
- ⊖ [Maxim Integrated Information](#)

## Optimize Your Supply Chain with WIN SOURCE Solutions

- ✓ Global Sourcing Solution
- ✓ Obsolete Management
- ✓ Cost Control Management
- ✓ Shortage Management
- ✓ Alternative Solution
- ✓ Excess Inventory Management