



**THE DATASHEET OF
MAX24188EVKIT#**





MAX24188 EV KIT

Evaluates: MAX24188

General Description

The MAX24188 EV Kit is an easy-to-use evaluation kit for the MAX24188 Low-Cost IEEE1588 Time Clock. An on-board high-stability TC-OCXO oscillator is provided to allow evaluation of 1588 performance with a variety of network PDV and impairment scenarios. Also, the board can accept an external oscillator input for testing alternate oscillators. The board provides SMB connectors for three device GPIO signals. Through these connectors clock and 1PPS signals can be input or output to lock the MAX24188 time clock to a master time clock or to lock other 1588 components to the MAX24188.

Typically the board is controlled by EV kit software running on a Windows PC through the USB interface. The board also has SPI and JTAG headers through which the MAX24188 can be controlled by a processor on another board as needed.

Demo Kit Contents

- ◆ MAX24188 Board
- ◆ Power Supply
- ◆ USB Cable

[Ordering Information](#) appears at end of data sheet.

Features

- ◆ GPIO SMB Connectors to Input or Output Clock Signals and 1PPS Signals
- ◆ Onboard TC-OCXO Provides Stable Reference for High-Quality Timing over IEEE1588
- ◆ Connectors and Component Sites for Alternate Oscillators as Needed
- ◆ Included Universal 5V Power Supply
- ◆ Jumpers to Configure Reset State of MAX24188, GPIO Termination, and More
- ◆ LEDs for Power Supplies Valid and Port Status
- ◆ Soldered MAX24188 for Best Signal Integrity
- ◆ Easy-to-Read Silkscreen Labels Identify the Signals Associated with All Connectors, Jumpers, and LEDs
- ◆ Windows®-Based Evaluation Software Provides Easy Configuration and Monitoring of the MAX24188 Device
- ◆ Evaluation Software Calls MAX24188 HAL Software and Structure is Similar to HAL Software

Minimum System Requirements

- ◆ PC Running Windows XP or later
- ◆ Available USB Port

Contents

1. Board Floorplan	4
2. Connections to the Board	5
2.1 Power-Supply Connection	5
2.2 USB Connection	5
2.3 Example Setup.....	5
3. Installing the Software	5
3.1 Troubleshooting Software Installation.....	5
4. Running the Software	6
5. Software User Interface.....	7
5.1 Status Display	7
5.2 Configuration Menu and Command Prompt	8
5.2.1 Navigating Menus and Changing Settings.....	8
5.2.2 Configuring the Device.....	8
5.2.3 Other Commands.....	8
5.3 Configuration Menu Detailed Descriptions	8
6. Jumpers, Connectors and LEDs.....	14
7. Component List	17
8. Schematics	19
9. Ordering Information.....	19
10. Revision History	19

List of Figures

Figure 1. MAX24188 EV Kit Board Floorplan	4
Figure 2. Example Setup	5
Figure 3. User Interface Main Screen.....	7

List of Tables

Table 1. Status Display Fields	7
Table 12. MAIN Menu.....	9
Table 13. CONFIG SCRIPTING Menu	9
Table 14. GPIO PINS Menu	9
Table 16. 1588 TIME ENGINE Menu	9
Table 17. 1588 EVENT GENERATORS Menu	11
Table 18. PEG1/PEG2 COMMANDS Submenu.....	11
Table 19. 1588 TIMESTAMPERS Menu	11
Table 27. LOCK TO PPS Menu.....	12
Table 28. TEST Menu.....	13
Table 1. Power and Reset Components.....	14
Table 2. MAX24188 REFCLK Jumpers and Connectors	14
Table 3. MAX24188 Pin Configuration Jumpers	14
Table 5. MAX24188 GPIO1 Jumpers and Connectors.....	15
Table 6. MAX24188 GPIO2 Jumpers and Connectors.....	15
Table 7. MAX24188 GPIO3 Jumpers and Connectors.....	15
Table 8. Processor and Debug Jumpers and Connectors	15

1. Board Floorplan

When the board is oriented as shown in Figure 1, The 5V power supply and USB cable included with the kit are connected to jacks J1 and J2 at the top of the board. The board ships with a TCXO mounted in the Y3 oscillator position and a 25MHz XO in the Y1 position. See section 6 for detailed descriptions of the board's jumpers, connectors and LEDs. The same PCB is also used for the MAX24288 EV kit, and many components needed for the MAX24288 EV kit are not populated for the MAX24188 EV kit including U5, U7, J29 and J31.

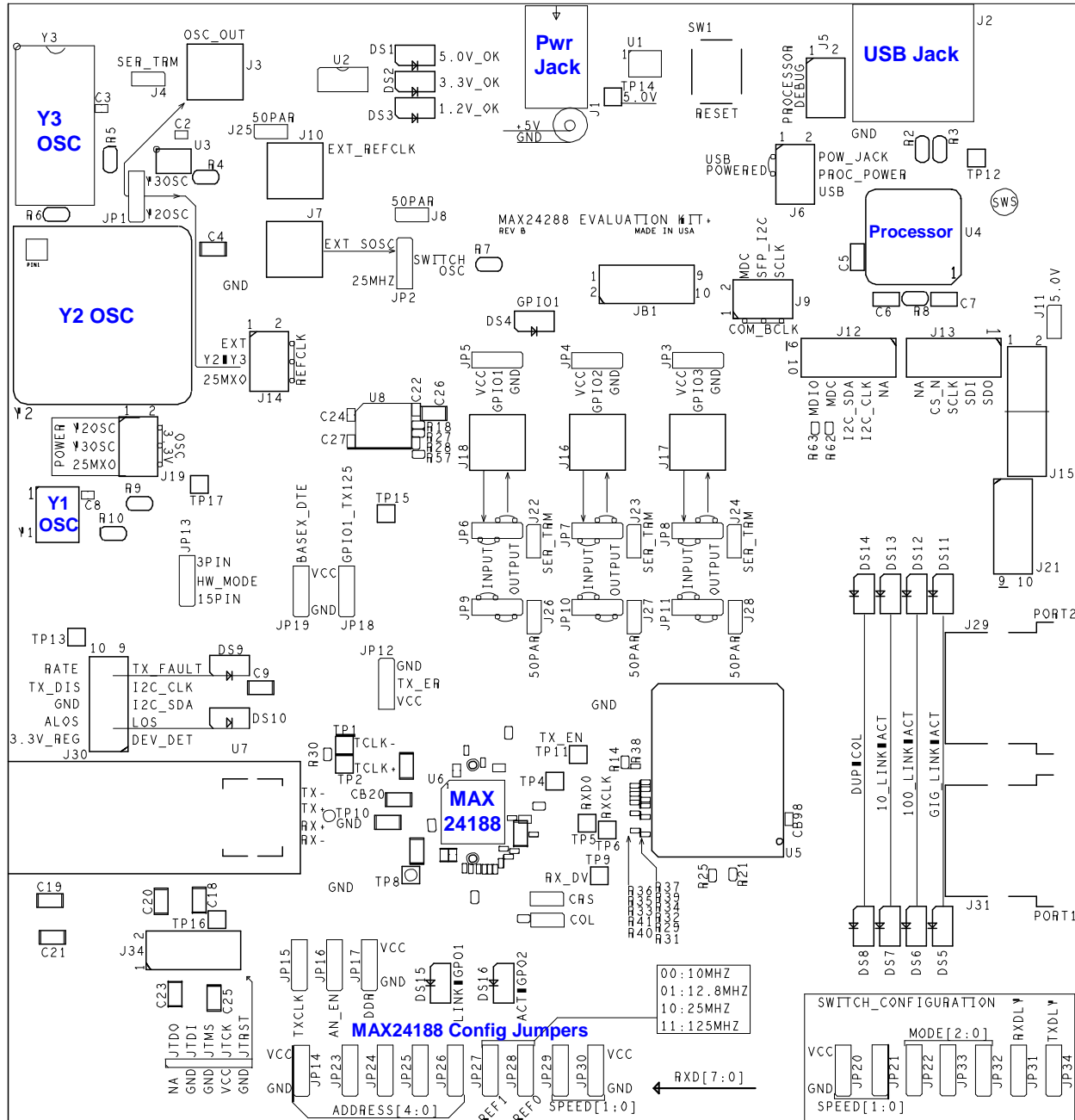

Figure 1. MAX24188 EV Kit Board Floorplan

2. Connections to the Board

2.1 Power-Supply Connection

The board is powered through connector J1 using the provided AC wall-plug 5V power supply. LED DS1 illuminates to indicate that the board is powered.

2.2 USB Connection

The MAX24188 EV kit software application communicates with the EV kit board through USB connector J2.

2.3 Example Setup

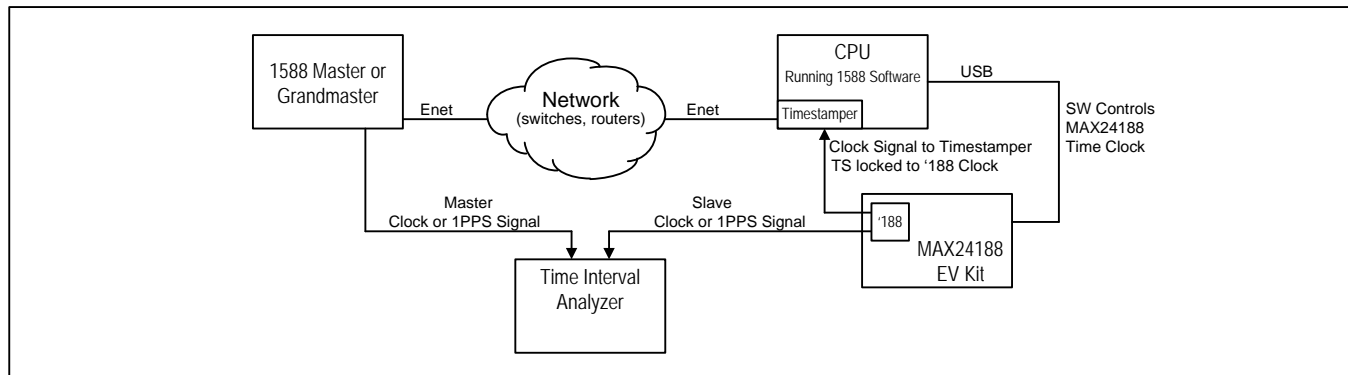

Figure 2. Example Setup

3. Installing the Software

Important Note: Do not connect the board to the PC until after installing the software. The device driver for the USB microcontroller will not be installed correctly.

Follow these steps to install the MAX24188 EV Kit software:

1. To install the software, run max24188evk.exe. The latest version of the EV Kit software can be downloaded from the Microsemi website or requested from Microsemi timing products technical support.
2. In the window that indicates the publisher could not be verified, click **Run**.
3. Follow the prompts in the MAX24188 Eval Kit setup wizard, For a default installation, click **Next** three times.
4. Connect the power cord to the J1 connector on the EV Kit board.
5. Connect a USB cable from a USB jack on the PC to the J2 connector on the EV Kit board.
6. In the notification area, Windows will indicate "Installing device driver" and then indicate "Freescale CDC Device (COM6) Device driver software installed successfully."

The text "COM6" indicates the virtual COM port number assigned to the board. This number varies from system to system. Write down the assigned number to use when running the EV Kit software.

If Windows does not show the messages above then verify that the board is powered and is connected to the PC. If the board was already connected to the PC before installing the software then see follow the troubleshooting steps in section 3.1.

3.1 Troubleshooting Software Installation

If the board was connected to the PC before installing the software or if the EV kit software does not list the board's COM port number as an option, then follow these steps:

1. In Windows, go to the Device Manager. In recent versions of Windows this is done by going to **Control Panel** and double-clicking **System**. Then in the upper-left corner click **Device Manager**.

2. In the Device Manager window, under **Other devices**, right-click on **Unknown device** and select **Uninstall**. In the **Confirm Device Uninstall** pop-up click **OK**.
3. In **Control Panel** double-click **Programs and Features**.
4. Right-click on **MAX24188 Eval Kit** and select **Uninstall**.
5. Disconnect power and USB cables from the EV Kit board.
6. Follow the steps in section [3](#).

4. Running the Software

To run the software, double-click on the **MAX24188 Eval Kit** shortcut on the desktop, or in the Windows Start menu, select **All Programs** → **Microsemi** → **MAX24188 Eval Kit**.

At the prompt enter the COM port number assigned to the board in step 6 in section [3](#).

The software then displays its main menu, as shown in [Figure 2](#).

To start communication with the MAX24188 on the EV kit board, type **1** then **Enter** to create the MAX24188 HAL. If the software and the USB device driver have been installed correctly then regular screen updates begin, the **TE SEC** field increments once per second, and **TE NS** fields displays ever-changing values.

If the software exits unexpectedly then run the software again and specify a different COM port number. If none of the listed COM port numbers is correct then follow the troubleshooting steps in section [3.1](#).

5. Software User Interface

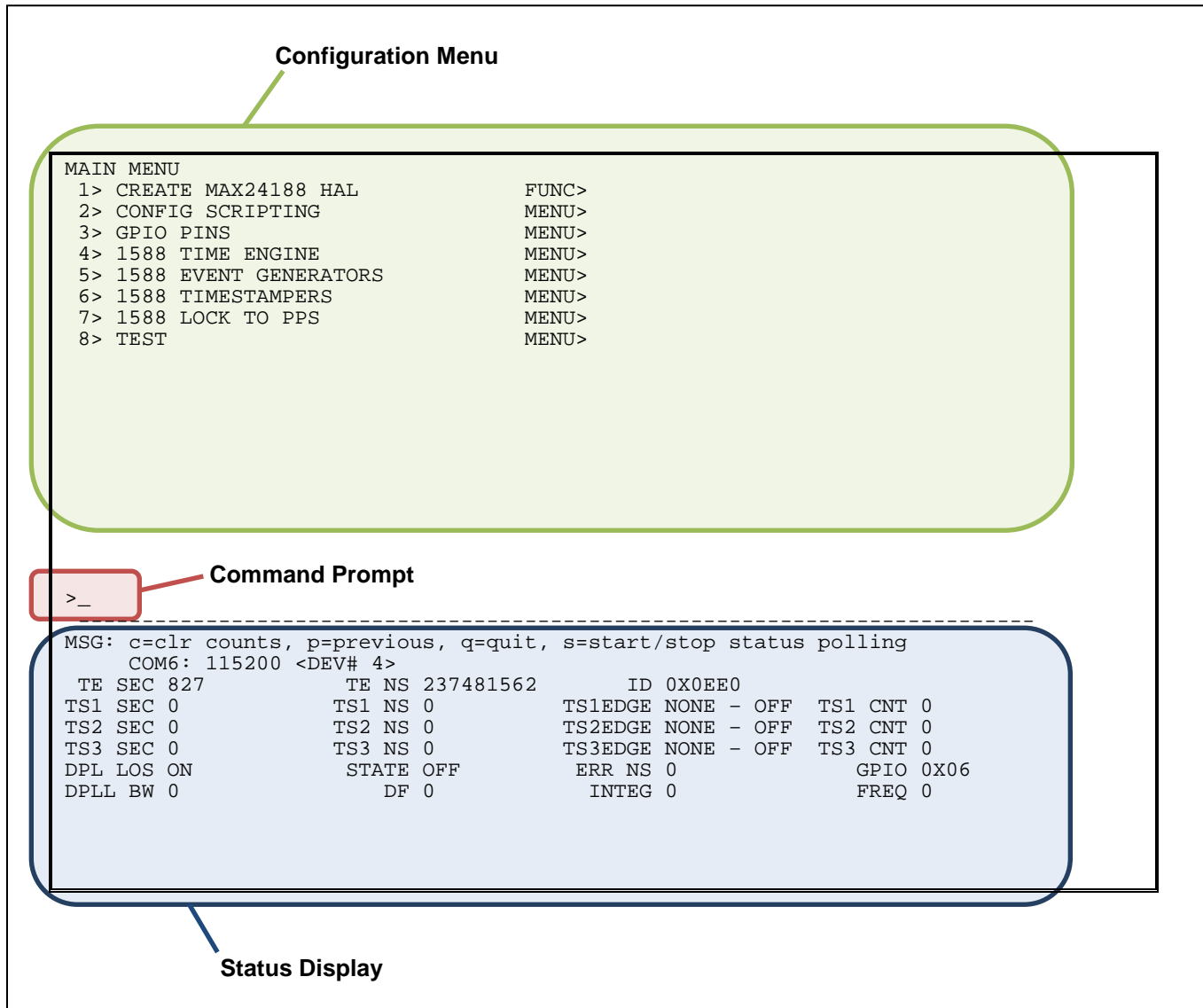

Figure 3. User Interface Main Screen

5.1 Status Display

The status display area (see the bottom of Figure 2) shows the latest data polled from the device. To start software polling and updating of these fields, select **CREATE MAX24188 HAL** in the main menu. To start or stop polling, use the **s** command at the command prompt. [Table 1](#) lists and describes the status display fields.

Table 1. Status Display Fields

Row	Field	Description
1	TE SEC	Time engine seconds field
1	TE NS	Time engine nanosecond field
1	ID	Value read from the MAX24188 ID register
2	TS1 SEC	Timestamper 1, timestamp seconds field
2	TS1 NS	Timestamper 1, timestamp nanoseconds field
2	TS1EDGE	Timestamper 1, timestamp edge type, 0=falling, 1=rising
2	TS1 CNT	Count of timestamps done by timestamper 1 since HAL started or last c command.
3	TS2 SEC	Timestamper 2, timestamp seconds field

Row	Field	Description
3	TS2 NS	Timestamper 2, timestamp nanoseconds field
3	TS2EDGE	Timestamper 2, timestamp edge type, 0=falling, 1=rising
3	TS2 CNT	Timestamper 2, count of timestamps done since HAL started or last c command
4	TS3 SEC	Timestamper 3, timestamp seconds field
4	TS3 NS	Timestamper 3, timestamp nanoseconds field
4	TS3EDGE	Timestamper 3, timestamp edge type, 0=falling, 1=rising
4	TS3 CNT	Timestamper 3, count of timestamps done since HAL started or last c command.
5	DPL LOS	Hardware/Software DPLL loss of signal
5	STATE	Hardware/Software DPLL state
5	ERR NS	Hardware/Software DPLL time error in nanoseconds
5	GPIO	MAX24188 GPIO status register (GPIO_SR) bits 6:0
6	DPLL BW	Hardware/Software DPLL bandwidth
6	DF	Hardware/Software DPLL damping factor
6	INTEG	Hardware/Software DPLL integral path control
6	FREQ	Hardware/Software DPLL frequency control

5.2 Configuration Menu and Command Prompt

5.2.1 Navigating Menus and Changing Settings

Figure 3 shows the main screen of the MAX24188 software. In the upper half of the screen the command menu has two columns. The left-hand column shows numbered command/menu options. The right-hand column indicates what happens when an option is chosen. **FUNC>** indicates that a function is executed, **LIST>** indicates a list of choices will be presented, and **MENU>** indicates that the user will be taken to a submenu. Data types such as **UINT32>** or **STR>** indicate that a value with the specified data type can be entered. **UINT32>**, for example, means a 32-bit unsigned integer. **STR>** means text string.

To change the device configuration, the user types a number at the command prompt followed by the **Enter** key. If the option selected has a data type in the right-hand column, such as **UINT32>** then the cursor moves to the right of the data type. The user then enters the desired value followed by the **Enter** key. The cursor then moves back to the command prompt area.

If the option selected has **LIST>** in the right-hand column, then the cursor moves to the right of the **LIST>** text and a list of options is shown in an additional column on the right. The user then enters the option number from the list followed by the **Enter** key. The value next to **LIST>** then changes to the option selected, and the cursor moves back to the command prompt area.

5.2.2 Configuring the Device

All menus of the software are designed to have a two-step configuration process:

1. Configure the relevant values using data-type or **LIST>** menu options.
2. Configure the HAL or the device using a **FUNC>** menu option.

For example, in the **GPIO PINS** menu, some or all of the parameters in the menu are configured and then **CONFIG GPIO** is selected to write MAX24188 device registers.

5.2.3 Other Commands

In addition to menu item numbers, the following commands are also valid at the command prompt:

- c** – clear counts in status area
- p** – return to previous menu (when in a submenu)
- q** – quit the program
- s** – stop/start status polling

5.3 Configuration Menu Detailed Descriptions

Table 2. MAIN Menu

Name	Description
CREATE MAX24188 HAL	This function creates the MAX24188 HAL and starts polling device status. The three MAX24188* fields below must be set before this function is executed.
CONFIG SCRIPTING	Opens the CONFIG SCRIPTING menu. See Table 13 .
GPIO PINS	Opens the GPIO PINS menu. See Table 14 .
1588 TIME ENGINE	Opens the 1588 TIME ENGINE menu. See Table 16 .
1588 EVENT GENERATORS	Opens the 1588 EVENT GENERATORS menu. See Table 17 .
1588 TIMESTAMPERS	Opens the 1588 TIMESTAMPERS menu. See Table 19 .
1588 LOCK TO PPS	Opens the 1588 LOCK TO PPS menu. See Table 27 .
TEST	Opens the TEST menu. See Table 28 .

Table 3. CONFIG SCRIPTING Menu

Name	Description
READ CONFIGURATION	Function reads configuration information from the file specified by the READ CONFIG FILE NAME parameter below.
WRITE CONFIGURATION	Function writes configuration information to the file specified by the WRITE CONFIG FILE NAME parameter below.
READ CONFIG FILE NAME	The file name for the READ CONFIGURATION function above. The file extension is .cfg.
WRITE CONFIG FILE NAME	The file name for the WRITE CONFIGURATION function above. The file extension is .cfg.

Table 4. GPIO PINS Menu

Name	Description
CONFIG GPIO	Function writes GPIO configuration from the fields below to MAX24188 register GPIOCR1 or GPIOCR2 for the pin(s) specified by GPIO CONFIG SELECT below.
GPIO CONFIG SELECT	Specifies one or all of {GPO1, GPO2, GPIO1-7} to be configured by the CONFIG GPIO function above.
GPOx MODE, GPIOx MODE (9 fields total)	Specify high-impedance, low, high, and several other options. Other options are pin-dependent and include: INT = interrupt output EXT CLK = Output the PTP_CLKO signal from the time engine REFCLK PLL 125 MHZ = Output 125MHz from the reference clock PLL RX 125/25 MHZ = Output clock from receive clock recovery PLL; the frequency is specified by GPIO RX PLL CLK MODE in the DATA PATH menu. RX 125/25 MHZ SQUELCH = same as RX 125/25 MHZ above and the output clock signal is squelched when certain receiver conditions occur such as LOS or ALOS LOS or ALOS = Output real-time link status, 1= link up CRS = Output carrier sense status PEG1 = Output signal generated by Programmable Event Generator 1 PEG2 = Output signal generated by Programmable Event Generator 2 See Table 6-4 through Table 6-6 in the MAX24188 data sheet. Note that GPIO4 through GPIO7 are the TXD4 through TXD7 pins, which are not available when the parallel MII interface is configured as GMII.

Table 5. 1588 TIME ENGINE Menu

Name	Description
SET TIME	Function writes time from TIME SEC and TIME NS below to the MAX24188 time engine.
TIME SEC	Specifies the seconds portion of the time for the SET TIME function above. <i>Affects the MAX24188 TIME register field.</i>
TIME NS	Specifies the nanoseconds portion of the time for the SET TIME function above. <i>Affects the MAX24188 TIME register field.</i>
SET FREQ OFFSET	Function adjusts the MAX24188 PERIOD register from its nominal value of 8.0ns by the amount specified in the FREQ OFFSET field below.
FREQ OFFSET +/- PPT	Specifies a time engine frequency offset in parts per trillion (PPT). <i>Affects the MAX24188 PERIOD register field.</i>
DO TIME BUILD OUT	Function adjusts MAX24188 time engine time smoothly. Time is advanced by the amount specified by TBO ADJUSTMENT (below) over a duration specified by TBO DURATION (below). For example, if TBO ADJUSTMENT is 100ns and TBO DURATION is 1s then DO TIME BUILD OUT advances time in the MAX24188 time

Name	Description
	engine by an extra 100ns, but it does this extra advance at a rate of 100ns/1s=0.1ppm. DO TIME BUILD OUT makes one-time or repeated used of the precise time adjustment feature described in section 6.13.1.3 of the MAX24188 data sheet. <i>Affects register fields PER_ADJ and ADJ_CNT.</i>
TBO DURATION +/- NS	Specifies the total time duration during which the time is adjusted by the DO TIME BUILD OUT function above.
TBO ADJUSTMENT +/- NS	Specifies the total time adjustment desired for the DO TIME BUILD OUT function above.
CONFIG EXT CLK & PTP_CLKO	Function configures the MAX24188 external clock and PTP_CLKO output clock features using the settings of the EXT CLK SOURCE through PTP_CLKO INVERT fields below. See MAX24188 data sheet section 6.13.1.4 for more information about the external clock syntonization feature. See MAX24188 data sheet section 6.13.2 for more information about the PTP_CLKO output clock.
EXT CLK SOURCE	Specifies the input signal pin for the MAX24188 external clock syntonization feature. <i>Affects register field PTPCR3.EXT_SRC.</i>
EXT CLK ENABLE	Enable/disable control for the MAX24188 external clock syntonization feature. <i>Affects register field PTPCR3.EXT_CLK_ENA.</i>
EXT CLK DIVIDE	Specifies the external clock divider value. <i>Affects register field PTPCR3.EXT_DIV.</i>
EXT CLK LIMIT	Specifies the maximum number of nanoseconds to adjust the time engine accumulator period from the nominal value set by the MAX24188 PERIOD register. <i>Affects register field PTPCR3.EXT_LIM.</i>
EXT CLK PER NS (16-255)	Specifies the period of the external clock after being divided by the EXT CLK DIVIDE value. <i>Affects register field PTPCR3.EXT_PER.</i>
PTP_CLKO DIVIDE (0=NO DIV)	Specifies the divide value for the PTP_CLKO signal. PTP_CLKO frequency is 125MHz divided by this value. <i>Affects register field PTPCR2.CLKO_DIV.</i>
PTP_CLKO INVERT	Invert/non-invert control. <i>Affects register field PTPCR2.CLKO_INV.</i>

Table 6. 1588 EVENT GENERATORS Menu

Name	Description
CONFIG PEG	Function configures the MAX24188 programmable event generator(s) (PEGs) using settings from the fields below and the PEG1 COMMANDS and PEG2 COMMANDS submenus.
PEG CONFIG SELECT	Specifies one or both of the PEGs to be configured by the CONFIG PEG function above.
PEG1 MODE	Allows the user to specify that PEG1 generate one of several common clock frequencies from 0.5Hz through 31.25MHz. If the CUSTOM option is selected then the user can specify a custom PEG command script in the PEG1 COMMANDS submenu.
PEG1 OFFSET NS	When PEG1 MODE≠CUSTOM then this field specifies an offset from the one-second boundary for the first edge generated by the PEG. If PEG1 OFFSET=0 then PEG1 is configured to generate the first output signal edge when the time engine's nanosecond field equals 0. If, for example, PEG1 OFFSET=-10 then PEG1 is configured to generate the first output signal edge when the time engine's nanoseconds field equals 999,999,990 (i.e. 10ns before the nanoseconds field rolls over to 0).
PEG2 MODE	Same as PEG1 MODE above but for PEG2.
PEG2 OFFSET NS	Same as PEG1 OFFSET above but for PEG2.
PEG1 COMMANDS	Opens the PEG1 COMMANDS Menu where a custom PEG1 command script can be entered. See Table 18 .
PEG2 COMMANDS	Same as PEG1 COMMANDS above but for PEG2.

Table 7. PEG1/PEG2 COMMANDS Submenu

Name	Description
CMD RESOLUTION	Specifies 1ns or 1/256ns resolution for the 16-bit and 32-bit relative time commands written to the PEG command FIFO. <i>Affects register field PEGCR.P1RES for PEG1 and PEGCR.P2RES for PEG2.</i>
CMD WORD LENGTH	Specifies the number of words of CMD WOR 0 through CMD WORD 15 below that the software should write to the PEG command FIFO. CMD WORD LENGTH=1 indicates that only CMD WORD 0 should be written. CMD WORD LENGTH=4 indicates that CMD WORD 0 through CMD WORD 3 should be written.
CMD WORD 0 – CMD WORD 15	Specifies up to 16 entries to be written to the PEG command FIFO. The CMD WORD LENGTH field above specifies the number of entries that are written to the PEG command FIFO.

Table 8. 1588 TIMESTAMPERS Menu

Name	Description
CONFIG TS	Function configures the MAX24188 timestampers using settings from the fields below and the PACKET TS FIFO ENABLES submenu.
TS CONFIG SELECT	Specifies one or all of the timestampers to be configured by the CONFIG TS function above.
TS1 SOURCE	Specifies the source of the signal to be timestamped by timestamp 1. <i>Affects register field TSCR.TS1SRC_SEL.</i>
TS1 EDGE	Specifies whether positive edges, negative edges or both should be timestamped by timestamp 1. <i>Affects register field TSCR.TS1EDGE.</i>
TS1 OFFSET NS	Specifies an offset in nanoseconds that software adds to each timestamp generated by the MAX24188. This field allows software to correct for cable delays, signal skews, etc.
TS1 DIVIDER 1	Specifies the timestamp 1 divider 1 setting. One or both of the TS1 dividers can be used to divide down the frequency of the input signal that goes to timestamp 1 in order to reduce the number of edges that must be timestamped. The input signal frequency is divided by value entered + 1. <i>Affects register field TS1_DIV1.</i>
TS1 DIVIDER 2	Specifies the timestamp 1 divider 2 setting. <i>Affects register field TSCR.TS2SRC_SEL.</i>
TS2 SOURCE	Specifies the source of the signal to be timestamped by timestamp 2. <i>Affects register field TSCR.TS2SRC_SEL.</i>
TS2 EDGE	Specifies whether positive edges, negative edges or both should be timestamped by timestamp 2. <i>Affects register field TSCR.TS2EDGE.</i>
TS2 OFFSET NS	Same as TS1 OFFSET NS above but for timestamp 2.

Name	Description
TS3 SOURCE	Specifies the source of the signal to be timestamped by timestamp 3. <i>Affects register field TSCR.TS3SRC_SEL.</i>
TS3 EDGE	Specifies whether positive edges, negative edges or both should be timestamped by timestamp 3. <i>Affects register field TSCR.TS3EDGE.</i>
TS3 OFFSET NS	Same as TS1 OFFSET NS above but for timestamp 3.

Table 9. LOCK TO PPS Menu

Name	Description																			
CONFIG LOCK TO PPS	<p>Function configures the evaluation software using settings from the fields below to work with the MAX24188 hardware to form a hardware/software PLL that locks to an input 1PPS signal. In this PLL, timestamp 1 (TS1) in the MAX24188 timestamps edges of a 1PPS input signal. The edges of this signal are assumed to occur at the exact one-second boundary. Therefore ideally the timestamp nanoseconds field should be 0. The difference between the nanosecond field and zero is the error information used to control the PLL.</p> <p>Note 1: TS1 must be configured to timestamp an input 1PPS signal in the 1588 TIMESTAMPERS Menu (Table 19) before executing the CONFIG LOCK TO PPS function.</p> <p>Note 2: The evaluation software controls the time and/or frequency of the MAX24188 time engine when PLL MODE below is not OFF. Therefore previous settings of time engine values may be overwritten by the evaluation software when the LOCK TO PPS PLL is enabled.</p>																			
PLL MODE	<p>Specifies operating mode of the hardware/software PLL.</p> <table border="1" data-bbox="532 890 1437 1514"> <thead> <tr> <th>Mode</th> <th>Description</th> </tr> </thead> <tbody> <tr> <td>OFF</td> <td>Disable the PLL</td> </tr> <tr> <td>FREERUN</td> <td>Ignore error information from TS1 and clock the time engine at the frequency specified by the FREE RUN FREQ PPM field below.</td> </tr> <tr> <td>FREQ MEASURE</td> <td rowspan="6">For debug only. These values force the hardware/software PLL into a particular operating state.</td> </tr> <tr> <td>FREQ ADJUST</td> </tr> <tr> <td>TIME ADJUST</td> </tr> <tr> <td>TIME MEASURE</td> </tr> <tr> <td>TIME BUILD OUT</td> </tr> <tr> <td>LOCK</td> </tr> <tr> <td>HOLDOVER</td> <td>Ignore error information from TS1 and clock the time engine at a holdover frequency averaged by the evaluation software while the PLL was locked to an input signal.</td> </tr> <tr> <td>AUTO FREQ LOCK</td> <td>Fully automatic PLL operation with frequency-only locking. When the PLL is locked its output frequency tracks the frequency of the input signal, but time is not adjusted. Therefore the MAX24188 time engine will have a fixed time offset vs. the source of the input signal.</td> </tr> <tr> <td>AUTO TIME LOCK</td> <td>Fully automatic PLL operation with time-and-frequency locking. When the PLL is locked the time and frequency of the MAX24188 time engine track the input signal.</td> </tr> </tbody> </table>	Mode	Description	OFF	Disable the PLL	FREERUN	Ignore error information from TS1 and clock the time engine at the frequency specified by the FREE RUN FREQ PPM field below.	FREQ MEASURE	For debug only. These values force the hardware/software PLL into a particular operating state.	FREQ ADJUST	TIME ADJUST	TIME MEASURE	TIME BUILD OUT	LOCK	HOLDOVER	Ignore error information from TS1 and clock the time engine at a holdover frequency averaged by the evaluation software while the PLL was locked to an input signal.	AUTO FREQ LOCK	Fully automatic PLL operation with frequency-only locking. When the PLL is locked its output frequency tracks the frequency of the input signal, but time is not adjusted. Therefore the MAX24188 time engine will have a fixed time offset vs. the source of the input signal.	AUTO TIME LOCK	Fully automatic PLL operation with time-and-frequency locking. When the PLL is locked the time and frequency of the MAX24188 time engine track the input signal.
Mode	Description																			
OFF	Disable the PLL																			
FREERUN	Ignore error information from TS1 and clock the time engine at the frequency specified by the FREE RUN FREQ PPM field below.																			
FREQ MEASURE	For debug only. These values force the hardware/software PLL into a particular operating state.																			
FREQ ADJUST																				
TIME ADJUST																				
TIME MEASURE																				
TIME BUILD OUT																				
LOCK																				
HOLDOVER	Ignore error information from TS1 and clock the time engine at a holdover frequency averaged by the evaluation software while the PLL was locked to an input signal.																			
AUTO FREQ LOCK	Fully automatic PLL operation with frequency-only locking. When the PLL is locked its output frequency tracks the frequency of the input signal, but time is not adjusted. Therefore the MAX24188 time engine will have a fixed time offset vs. the source of the input signal.																			
AUTO TIME LOCK	Fully automatic PLL operation with time-and-frequency locking. When the PLL is locked the time and frequency of the MAX24188 time engine track the input signal.																			
EVENTS PER SECOND	Specifies the number of edges per second in the input signal timestamped by TS1. For a 1PPS signal this field should be set to 1.																			
FREERUN FREQ PPM	Specifies a frequency offset vs. the frequency accuracy of the REFCLK oscillator for when PLL MODE above is set to FREERUN.																			
FREQ RATE OF CHANGE PPM/SEC	Specifies the maximum frequency rate of change that the evaluation software can use when locking to an input signal.																			
PLL BANDWIDTH, HZ	Specifies the bandwidth of the hardware/software PLL in Hz.																			
PLL DAMPING FACTOR	Specifies the damping factor of the hardware/software PLL. A typical value is 5. Larger numbers provide more damping, i.e. less peaking at the PLL corner frequency.																			

Table 10. TEST Menu

Name	Description
READ REGISTER	Function reads the register specified by the REGISTER ADDRESS fields below and displays the value in the REGISTER DATA fields below.
WRITE REGISTER	Functions writes the data value specified in the register data fields below into the register address specified by the REGISTER ADDRESS fields below.
REGISTER ACCESS MODE	Specifies the register access mode. MAX24188 USER MODE: The registers in Table 7-1 of the MAX24188 data sheet are at addresses 0-31 decimal, and the registers in Table 7-2 of the MAX24188 data sheet are at 32 (decimal) + SPI address. SW PHY0 (MDIO#8): Accesses the registers of PHY0 on the evaluation board's switch chip. SW PHY1 (MDIO#9): Accesses the registers of PHY1 on the evaluation board's switch chip. SW MAC (MDIO#A): Accesses the MAC registers of the evaluation board's switch chip for the port connected to the MAX24188. SFP CFG (I2C#A0): Accesses the SFP module's internal EEPROM memory. SFP PHY (I2C#AC): Accesses the SFP module's PHY registers.
REGISTER ADDRESS HEX	Specifies the register address in hexadecimal for the READ REGISTER and WRITE REGISTER functions above. When REGISTER ADDRESS DEC below is changed, this field is changed to match. The REGISTER ACCESS MODE field above specifies the register mapping.
REGISTER ADDRESS DEC	Specifies the register address in decimal for the READ REGISTER and WRITE REGISTER functions above. When REGISTER ADDRESS HEX above is changed, this field is changed to match.
REGISTER DATA HEX	Indicates the data value in hexadecimal from the last time the READ REGISTER function was executed or the last time one of the REGISTER DATA fields was change by the user.
REGISTER DATA DECIMAL	Indicates the data value in decimal from the last time the READ REGISTER function was executed or the last time one of the REGISTER DATA fields was change by the user.
READ SFP MODULE INFO	Functions reads and displays the data from the evaluation board's SFP module. To end the data display and return to the menu, press the ENTER key.

6. Jumpers, Connectors and LEDs

Table 11. Power and Reset Components

COMPONENT	LABEL AND TYPE	BASIC SETTING	SCHEMATIC PAGE	DESCRIPTION
J1	5V jack	Connected	4	Power jack for 5V wall adapter (supplied)
DS1 DS2 DS3	5.0V_OK LED 3.3V_OK LED 1.2V_OK LED	On	4	Lit when power is within range for 5V, 3.3V, and 1.2V, respectively
SW1	DUT_RST button	Unused	5	Manual reset for entire system

Table 12. MAX24188 REFCLK Jumpers and Connectors

Note: MAX24188 is intolerant of REFCLK signal changes during operation. To make REFCLK signal changes, power down the board, change the jumpers as needed then apply power to the board again.

COMPONENT	LABEL AND TYPE	BASIC SETTING	SCHEMATIC PAGE	DESCRIPTION
JP1	Y2OSC / Y3OSC selection 3-pin header	Jumper connecting pins 2 and 3	7	Drives SMB connector J3 and jumper J14 pin 1. Connect the Y3OSC pin to the center pin to connect the Y3 oscillator output to J3 and J14. Connect the Y2OSC pin to the center pin to connect the Y2 oscillator output to J2 and J14.
J3	OSC_OUT SMB connector	Not monitored	7	J3 is driven by a buffer sourced by the center pin of JP1.
J4	SER_TRM 2-pin header	Not monitored	7	Install a jumper on J4 to apply 50 ohm parallel termination to J3
J10	EXT_REFCLK SMB connector	Not monitored	7	External REFCLK oscillator input. Signal goes to J14 pin 1.
J25	50PAR 2-pin header	Not monitored	7	Jumper J25 to apply 50 ohm parallel termination to J10.
J14	REFCLK 2x3pin header	Jumper connecting pins 5 and 6	7	Connects 25MHz XO clock or Y2/Y3 clock or external clock to MAX24188 REFCLK pin. Frequency must match the settings of the REF[1:0] jumpers (see Table 3). Connect pins 1 and 2 to select the external clock signal from SMB J10. Connect pins 3 and 4 to select the Y2 or Y3 clock signal from JP1. Connect pins 5 and 6 to select the Y1 clock signal.
J19	OSC 3.3V POWER 2x3pin header	All jumpered	7	Connect/disconnect 3.3V power for oscillator components Y1, Y2 and Y3. Connect pins 1 and 2 to power Y3 Connect pins 3 and 4 to power Y2 Connect pins 5 and 6 to power Y1 Note: the silkscreen mistakenly has Y2OSC and Y3OSC labels swapped.

Table 13. MAX24188 Pin Configuration Jumpers

COMPONENT	LABEL AND TYPE	BASIC SETTING	SCHEMATIC PAGE	DESCRIPTION
JP27 JP28	REF[1:0] 3-pin headers	JP27: VCC JP28: GND	3	MAX24188 RXD[3:2] pins. At reset the values on these pins are latched into the internal REFCLK frequency register. 00=10MHz, 01=12.8MHz, 10=25MHz, 11=125MHz.

COMPONENT	LABEL AND TYPE	BASIC SETTING	SCHEMATIC PAGE	DESCRIPTION
JP12, JP13, JP14, JP15, JP16, JP17, JP18, JP19, JP23, JP24, JP25, JP26, JP29, JP30	Various labels 3-pin header	Not Jumpered	various	Not used in MAX24188 EV Kit

Table 14. MAX24188 GPIO1 Jumpers and Connectors

COMPONENT	LABEL AND TYPE	BASIC SETTING	SCHEMATIC PAGE	DESCRIPTION
J18	SMB Connector	Not jumpered	3	I/O connector for GPIO1.
JP5	GPIO1 3-pin header	Not jumpered	3	Can be used to bias GPIO1 high or low.
JP6 and JP9	3-pin headers	Not jumpered	3	To drive a signal from SMB J18 to GPIO1, jumper JP6 2-3 and JP9 2-3. To drive a signal from GPIO1 to SMB J18, jumper JP6 1-2 and JP9 1-2.
J22	2-pin header	Not jumpered	3	Install J22 to short the 30 ohm series termination at JP6.2.
J26	2-pin header	Not jumpered	3	Install J26 to apply 50 ohm parallel termination to JP9.2
DS4	LED	Off	3	Lit when GPIO1 is high.

Table 15. MAX24188 GPIO2 Jumpers and Connectors

COMPONENT	LABEL AND TYPE	BASIC SETTING	SCHEMATIC PAGE	DESCRIPTION
J16	SMB Connector	Not jumpered	3	I/O connector for GPIO2.
JP4	GPIO1 3-pin header	Not jumpered	3	Can be used to bias GPIO2 high or low.
JP7 and JP10	3-pin headers	Not jumpered	3	To drive a signal from SMB J16 to GPIO2, jumper JP7 2-3 and JP10 2-3. To drive a signal from GPIO1 to SMB J16, jumper JP7 1-2 and JP10 1-2.
J23	2-pin header	Not jumpered	3	Install J23 to short the 30 ohm series termination at JP7.2.
J27	2-pin header	Not jumpered	3	Install J27 to apply 50 ohm parallel termination to JP10.2

Table 16. MAX24188 GPIO3 Jumpers and Connectors

COMPONENT	LABEL AND TYPE	BASIC SETTING	SCHEMATIC PAGE	DESCRIPTION
J17	SMB Connector	Not jumpered	3	I/O connector for GPIO3.
JP3	GPIO1 3-pin header	Not jumpered	3	Can be used to bias GPIO3 high or low.
JP8 and JP11	3-pin headers	Not jumpered	3	To drive a signal from SMB J17 to GPIO3, jumper JP8 2-3 and JP11 2-3. To drive a signal from GPIO1 to SMB J17, jumper JP8 1-2 and JP11 1-2.
J24	2-pin header	Not jumpered	3	Install J24 to short the 30 ohm series termination at JP8.2.
J28	2-pin header	Not jumpered	3	Install J28 to apply 50 ohm parallel termination to JP11.2

Table 17. Processor and Debug Jumpers and Connectors

COMPONENT	LABEL AND TYPE	BASIC SETTING	SCHEMATIC PAGE	DESCRIPTION
J2 (USB)	USB jack	Connected	8	USB connector, attach to PC with supplied cable
J5	PROCESSOR DEBUG 2x3pin header	Not Connected	8	BDM connector for use with debug pod

COMPONENT	LABEL AND TYPE	BASIC SETTING	SCHEMATIC PAGE	DESCRIPTION
J9	COM_BCLK 2x3pin header	Not jumpered	5	Used to make a common communication clock. Jumper options allow to short MDC, I2C_CLK and SPI clock.
J12	2x5pin header	Jumpered 3-4, 5-6, 7-8, 9-10	5	Not used in MAX24188 EV Kit.
J13	2x5pin header	Jumpered 1-2, 3-4, 5-6, 7-8	5	Connection points for processor pins to MAX24188 SPI. Disconnect if connecting an external processor.
J15	2x7 header	Not used	5	Connection for external processor board
J21	2x5 header	Not used	5	SPI bus connection to external board such as Microsemi's DS31400DK.
J11	2-pin header	Not used	5	Place a jumper to connect 5V to J15 pin 2.
J34	2x5pin header	Jumpered 9-10	5	MAX24188 JTAG header. When not in JTAG mode the JTRST pin should be driven low by connecting pins 9 and 10.
JB1	2x5 header (just below the company logo)	Not jumpered	8	Connects to several GPIO on the processor to provide for future board application options.

7. Component List

DESIGNATION	QTY	DESCRIPTION	SUPPLIER	PART
Reference designators shown on next row (C1, ..., CB143)	81	0402 CERAM 1uF 10V	TDK	C1005X5R1A105M
C1, C2, C12, C13, C14, C22, C27, CB8, CB10, CB13, CB14, CB21, CB23, CB25, CB28, CB30, CB31, CB34, CB35, CB36, CB37, CB38, CB39, CB40, CB41, CB42, CB45, CB49, CB50, CB51, CB52, CB53, CB54, CB55, CB57, CB58, CB62, CB64, CB66, CB67, CB69, CB70, CB71, CB73, CB74, CB76, CB77, CB79, CB81, CB84, CB86, CB87, CB89, CB91, CB92, CB94, CB95, CB98, CB99, CB100, CB102, CB104, CB106, CB107, CB113, CB115, CB116, CB119, CB121, CB122, CB123, CB124, CB127, CB128, CB129, CB133, CB134, CB135, CB141, CB142, CB143				
Reference designators shown on next row (C3, ..., CB145)	41	0402 CERAM 0.01uF 16V 10%	Panasonic	ECJ-0EB1C103K
C3, C8, C10, C17, C24, CB3, CB7, CB12, CB26, CB27, CB47, CB59, CB60, CB61, CB63, CB65, CB68, CB72, CB75, CB78, CB80, CB82, CB83, CB85, CB88, CB90, CB93, CB96, CB97, CB101, CB103, CB105, CB108, CB109, CB110, CB111, CB114, CB117, CB118, CB120, CB145				
C4, C9, C11, C15, C16, C18, C19, C20, C21, C23, C25, C26, CB1, CB2, CB4, CB5, CB9, CB11, CB15, CB19, CB20, CB24, CB29, CB32, CB33, CB44, CB46, CB56, CB112, CB125, CB130, CB131, CB132, CB139, CB140, CB146	36	0603 CERAM 10uF 6.3V 20% MULTILAYER	Panasonic	ECJ-1VB0J106M
C5, CB18	2	0603 CERAM .1uF 16V 20% X7R	AVX	0603YC104MAT
C6, C7	2	0603 CERAM 22pF 25V 5% NPO	AVX	06033A220JAT
CB17, CB22	2	0603 CERAM 4.7uF 6.3V MULTILAYER	UNK	ECJ-1VB0J475M
CB43, CB48, CB126, CB136, CB137, CB138	6	CAP CER 3.3UF 4.0V X5R 0402	AMK	AMK105BJ335MV-F
CB6, CB16, CB144	3	D CASE TANT 470uF 6.3V 20%	KEM	T491D477M006AS
DB1	1	SCHOTTKY DIODE, 1 AMP 40 VOLT	International Rectifier	10BQ040
DS1, DS2, DS3,	11	LED, GREEN, SMD	Panasonic	LN1351C
DS4, DS15, DS16	3	LED, GREEN, SMD	Panasonic	LN1351C
DS9, DS10	2	LED, RED, SMD	Panasonic	LN1251C
GND_TP1, GND_TP2, GND_TP3, GND_TP4	4	STANDARD GROUND CLIP	KEYSTONE	4954
J1	1	2.0MM SURFACE MOUNT POWER JACK	CUI INC	PJ-002AH-SMT
J11	1	2 PIN HEADER, .100 CENTERS, VERTICAL	Samtec	TSW-102-07-T-S
J13, J34	4	TERMINAL STRIP, 10 PIN, DUAL ROW, VERT	DIG	S2012-05-ND
J15	1	HEADER, 14 PIN, DUAL ROW, VERT NOT POPULATED	Samtec	HDR-TSW-107-14-T-D
J2	1	TYPE B SINGLE RT ANGLE, BLACK	MOL	NA
J3, J10, J16, J17, J18	6	CONNECTOR, SMB, 50 OHM VERTICAL, 5PIN	AMP	413990-1
J4, J8, J22, J23, J24, J25, J26, J27, J28	11	100 MIL 2 POS JUMPER	NA	NA
J5, J6, J9, J14, J19	5	TERMINAL STRIP, 6 PIN, DUAL ROW, VERT	Samtec	TSW-103-07-T-D
JB1 J15, J21	3	TERMINAL STRIP, 10 PIN, DUAL ROW, VERT DO NOT POPULATE	DNP	DNP
JP1, JP3, JP4, JP5, JP6, JP7, JP8, JP9, JP10, JP11, JP12, JP13, JP14, JP15, JP16, JP17, JP18, JP19, JP23, JP24, JP25, JP26, JP27, JP28, JP29, JP30	34	100 MIL 3 POS JUMPER	NA	NA
LB1, LB3, LB4, LB9, LB10, LB11, LB12, LB13, LB14	9	FERRITE 3A 100 OHM AT 100 MHZ 1206 SMD	Steward	HI1206N101R-00

DESIGNATION	QTY	DESCRIPTION	SUPPLIER	PART
LB5, LB6, LB7, LB8	4	1uH ±10% 0805 Multilayer Ceramic 400 mA (ok to sub with 445-3156-1-ND)	Murata	LQM21FN1R0N00D
R1, R4, R5, R6, R7, R9, R10, RB5	9	RES 0603 30 Ohm 1/16W	Panasonic	ERJ-3GEYJ300V
R11, R18, R19, R21, R57, RB8, RB3	4	RES 0402 0 OHM 1/10W 5%	Panasonic	ERJ-2GEOR00X
R12, R17, R20, R22, R23, R29, R31, R32, R33, R34, R35, R36, R37, R38, R39, R40, R41, R42, R43, R44, R45, R46, R47, R48, R49, R50, R51, R52, R53, R54, R55, R56	32	RES 0201 30.0 OHM 1/16W 1%	Panasonic	ERJ-1GEJ300C
R13, R14, R25, R26, RB23, RB24, RB25, RB38, RB44, RB45, RB49, RB50, RB51, RB52, RB53, RB54, RB56, RB57, RB63, RB64, RB69, RB71, RB72, RB73, RB77, RB78, RB79, RB80, RB81, RB86, RB87,	31	RES 0402 10.0 KOHM 1/16W 1%	Panasonic	ERJ-2RKF1002X
R16, RB27, RB28, RB29	4	RES 0402 30.0 OHM 1/16W 1%	Panasonic	ERJ-2RKF30R0X
R30, R15	2	RES 0402 100 OHM 1/16W 1%	Panasonic	ERJ-2RKF1000X
R2, R3	2	RES 0603 33.2 Ohm 1/16W 1%	Panasonic	ERJ-3EKF33R2V
R24, R28, R62, R63, RB13, RB15, RB16, RB17, RB18, RB19, RB20, RB21, RB22, RB26, RB39, RB40, RB41, RB42, RB43, RB82	18	RES 0402 1.00 KOHM 1/16W 1%	Panasonic	ERJ-2RKF1001X
R27	1	RES 0402 1.40 KOHM 1/16W 1%	Panasonic	ERJ-2RKF1401X
R8	1	RES 0603 1.00M Ohm 1/16W 1%	Panasonic	ERJ-3EKF1004V
RB1, RB4, RB9, RB30, RB31, RB32, RB33, RB34, RB60, RN1	11	RES 0603 1.0K Ohm 1/16W 5%	Panasonic	ERJ-3GEYJ102V
RB14, RB84, RB85, R60	5	RES 0603 330 Ohm 1/16W 5%	Panasonic	ERJ-3GEYJ331V
RB2, RB11, RB35, RB36, RB37	5	RES 0402 49.9 OHM 1/16W 1%	Panasonic	ERJ-2RKF49R9X
RB6, RB10, RB83	3	RES 0603 10K Ohm 1/16W 5%	Panasonic	ERJ-3GEYJ103V
RB65	1	RES 0603 2.49K Ohm 1/16W 1%	Panasonic	ERJ-3EKF2491V
RB7	1	RES 0603 10.0K Ohm 1/16W 1%	Panasonic	ERJ-3EKF1002V
RPB5, RPB6, RPB7, RPB9, RPB13	6	RESISTOR, 4 PACK, 330 OHM 5PCT QUAD 0603	Panasonic	EXB-V8V331JX
RPB10, RPB11	2	RESISTOR, 4 PACK, 10K OHM 5PCT QUAD 0603	Panasonic	EXB-V8V103JX
RPB2, RPB3, RPB4	3	RESISTOR, 4 PACK, 33 OHM 5PCT QUAD 0603	Panasonic	EXB-V8V330JV
RPB8, RPB12	2	RESISTOR, 4 PACK, 4.7K OHM 5PCT QUAD 0603	Panasonic	EXB-V8V472JX
SW1	1	SWITCH MOM 4PIN SINGLE POLE	Panasonic	EVQPAE04M
TP1, TP2, TP3, TP4, TP5, TP6, TP7, TP8, TP9, TP10, TP11, TP12, TP13, TP15, TP16, TP17, TPB1, TPB2, TPB3, TPB4, TPB5, TPB6, TPB7, TPB8, TPB9, TPB10	26	TESTPOINT, 1 PLATED HOLE, DO NOT STUFF	NA	NA
U1	1	MICROPROCESSOR VOLTAGE MONITOR, 3.08V RESET, 4PIN SOT143	Maxim	MAX811TEUS-T
U2	1	VOLTAGE MONITOR 5, 3.3, 2.5, ADJ	Maxim	MAX6709AUB+
UB3, UB4, UB5, UB6, UB9, UB10, UB11, UB12, UB13, UB14, UB15, UB16, UB19, UB20	14	HIGH SPEED BUFFER	FAIRCHILD	NC7SZ86
U4	1	IC, HCS08 8-BIT MICROCONTROLLER, 32K FLASH, 2K RAM, 2 UART, 2 SPI, I2C, USB, -40 TO 85C, 64 PIN LQFP	FREESCALE	MC9S08JM32CLH-ND
U5	1	RTL8363 PHY	REALTEK	RTL8363C
U6	1	MAX24188 QFN 8X8	MICROSEMI	MAX24188ETK+
U7	1	SFP host / receptacle	PARTS_KIT	SFP_HOST-TYCO

DESIGNATION	QTY	DESCRIPTION	SUPPLIER	PART
U8	1	IC, LINEAR REG ADJ, 2A, 14TSSOP-EP	MAXIM	MAX8526EUD+
UB2, UB7, UB17, UB18, UB21	5	IC, LINEAR REGULATOR, 1.5W, 3.3V OR ADJ, 1A, 16 PIN TSSOP-EP	Maxim	MAX1793EUE-33
XB1	1	XTAL, HC49SD, 12.0000MHz +/-50PPM, CL=20PF	FOX	FOXSDLF-120-20
Y1	1	OSCILLATOR LVCMOS, 3.3V, 25 MHZ, 4 PIN SMD	Connor-Winfield	MX010-025.0M
Y2	1	OSCILLATOR, VECTRON OCXO, 3.3V, 12.8 MHZ, 5 PIN THROUGH-HOLE	VEC	MC853X4-035W
Y3	1	OSCILLATOR, RAKON TC-OCXO, 3.3V, 10MHZ RFPO-30-RX-C-LF	RAKON	P5299LF
J9	1	TERMINAL STRIP, 6 PIN, DUAL ROW, VERT NOT POPULATED	Samtec	TSW-103-07-T-D NOT POPULATED
TP14	1	TESTPOINT, 1 PLATED HOLE RED	KEYSTONE	5000R
U3,UB1,UB8	3	TINYLOGIC HIGH SPEED 2-INPUT AND GATE, 5 PIN SOT23	Fairchild	NC7SZ08M5

Not Populated:

DS5, DS6, DS7, DS8, DS9, DS10, DS11, DS12, DS13, DS14
 J7, J12, J29, J30, J31, J32, J33, JP2, JP20, JP21, JP22, JP31, JP32, JP33, JP34
 U5, U7

8. Schematics

The MAX24188 EV Kit board design is a bill of materials modification of the MAX24287 EV Kit. See the following pages for the MAX24287 EV Kit schematics. The list of components that are not populated in the MAX24188 EV Kit board is shown at the end of section 7 above.

9. Ordering Information

PART	TYPE
MAX24188EVKIT	Evaluation Kit

10. Revision History

REVISION DATE	DESCRIPTION
10/11	Initial Release
2012-05	Reformatted for Microsemi. No content change.

MAX24287 EVKIT REV1

D

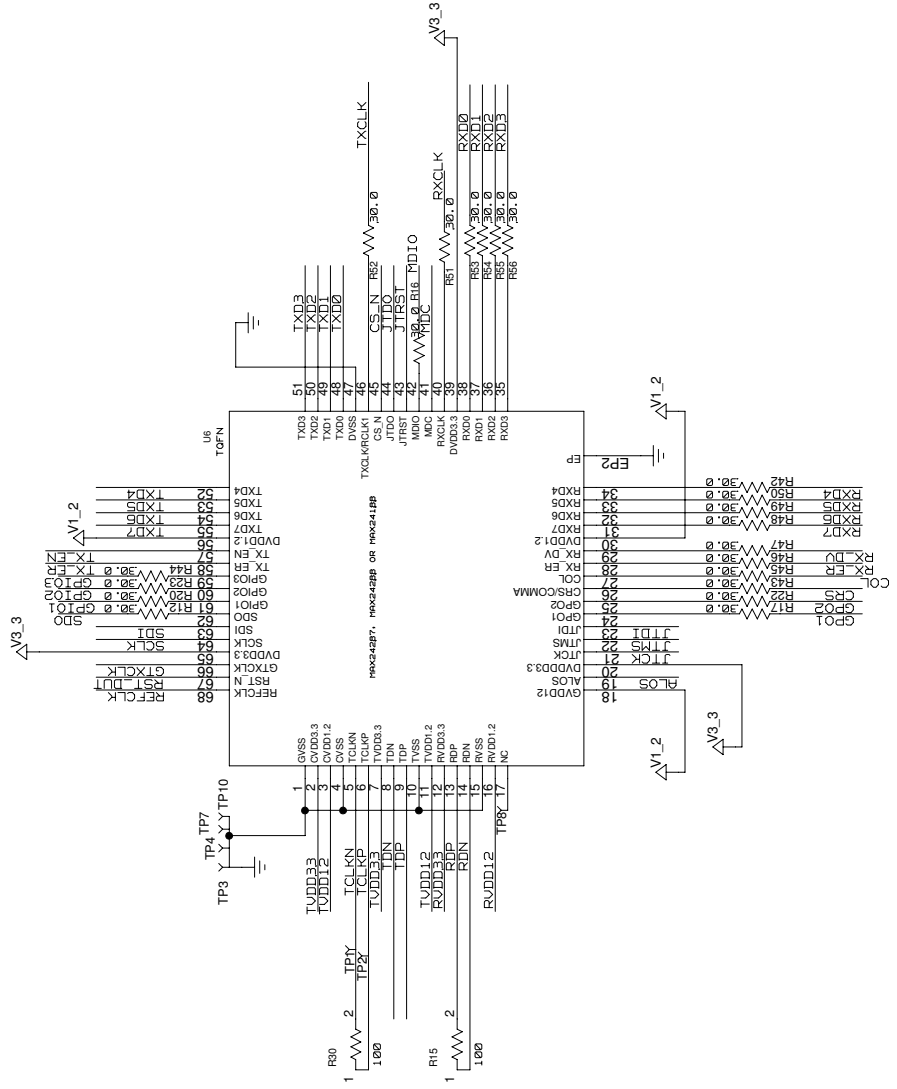

C

B

A

Top Level Hierarchy

TITLE: MAX24287 EVKIT

ENGINEER: Steve Scl

8

7

6

5

4

3

Switch Hierarchy block.
Contents on page 9

The diagram shows a central block labeled **REALTEK_SWITCH_DN** with various ports and internal components:

- Left side ports:** RXD0, Y_TP5, RXD0, RXD1, RXD2, RXD3, RXD4, RXD5, RXD6, RXD7, RX_DV, Y_TP9, RX_DV, RX_ER, Y_TP6, RXCLK, Y_TP8, GTXCLK, LED0, LED1, LED2, LINKA0, LINKA1, LINKA2, GTXCLK.
- Right side ports:** TXD0, TXD1, TXD2, TXD3, TXD4, TXD5, TXD6, TXD7, TX_EN, Y_TP11, TX_EN, TXCLK, TX_ER.
- Internal components:** LED0, LED1, LED2, LINKA0, LINKA1, LINKA2, SWITCH_OSC, RESET, CRS, COL, MDIO, MDC.
- External connections:**
 - CRS 2 to 1, 132
 - COL 2 to 1, 133
 - MDIO
 - MDC
 - SWITCH_OSC
 - RESET

Top Level Hierarchy

TITLE: MAX24287 EVB

ENGINEER: Steve Sol

8

7

6

5

4

3

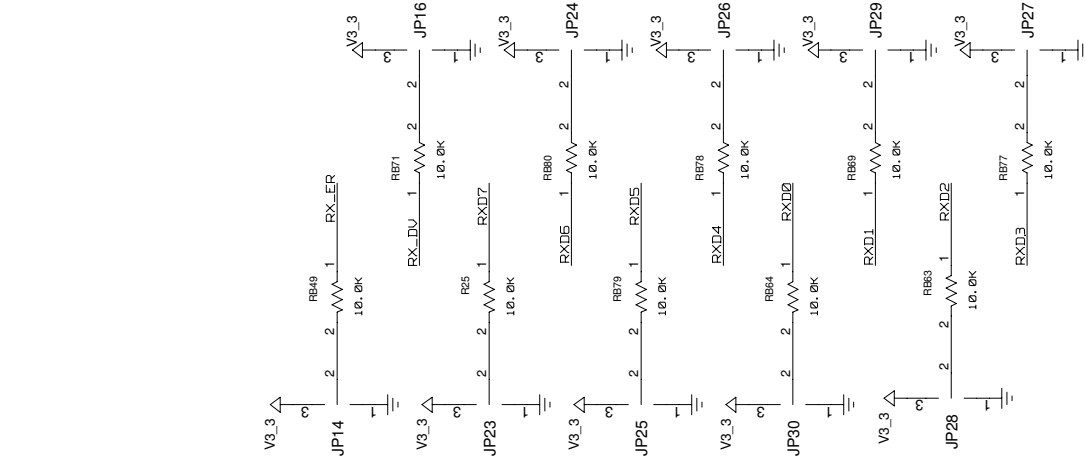
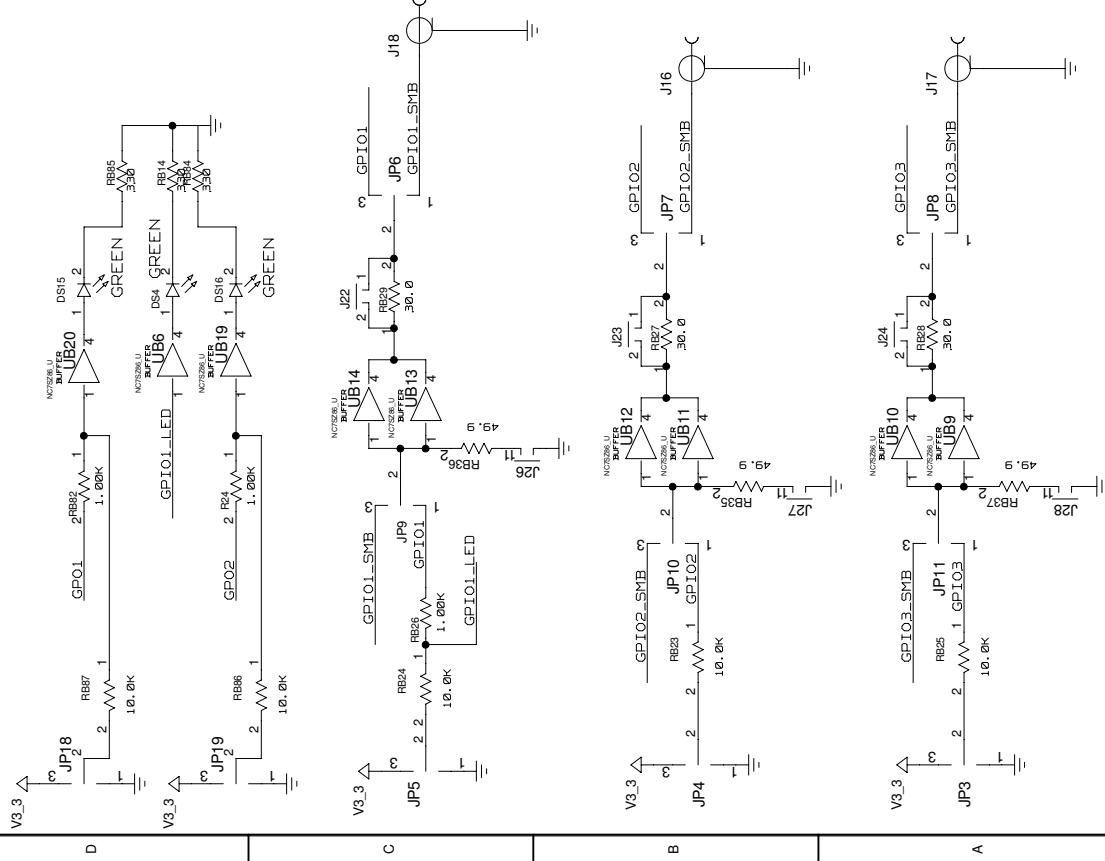

Top Level Hierarchy
 TITLE: MAX24287 EVU

ENGINEER: Steve Sol

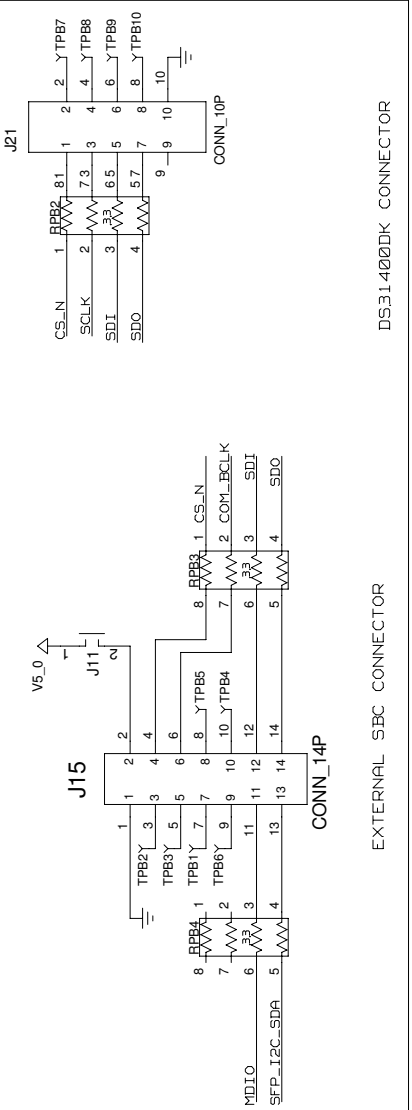

EXTERNAL SBC CONNECTOR

DS3140DK CONNECTOR

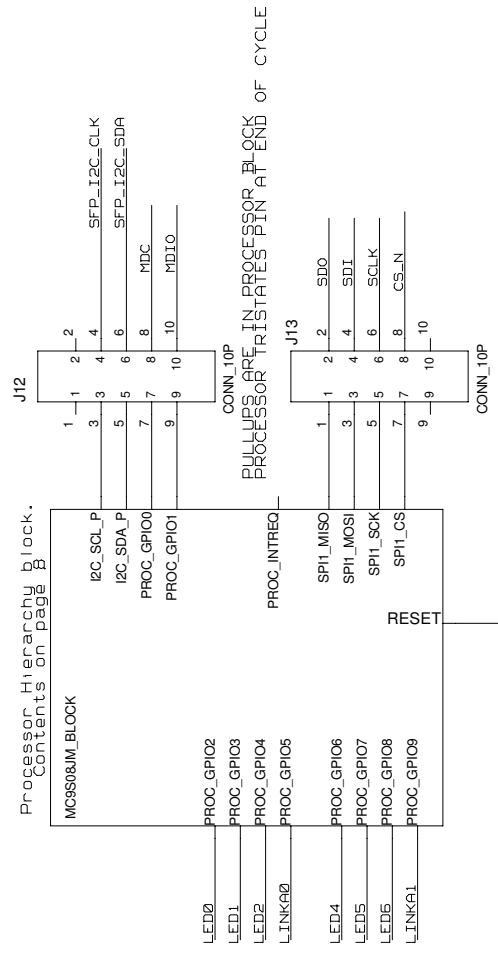

PULLUPS ARE IN PROCESSOR BLOCK AT END OF CYCLE

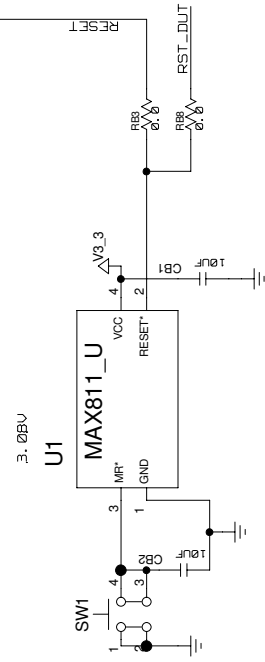

Top Level Hierarchy
 TITLE: MAX24287 EVU
 ENGINEER: Steve Sc...

3

4

5

6

7

8

3.3V UB17

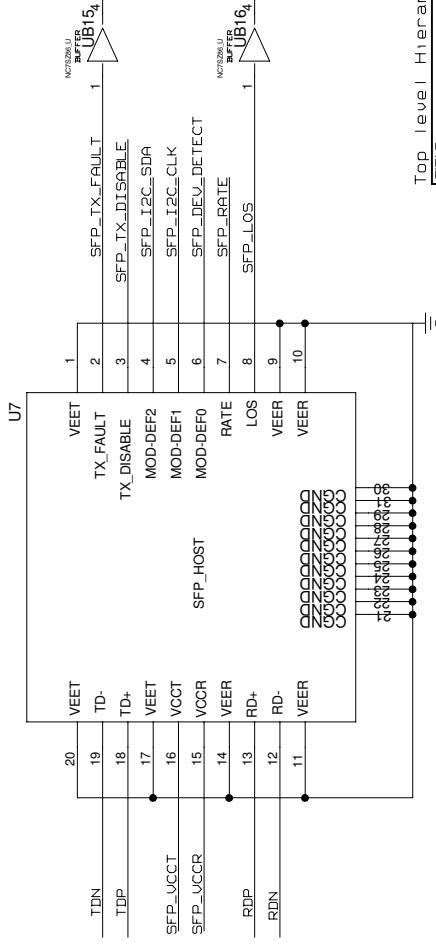
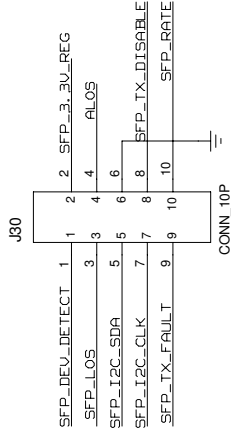
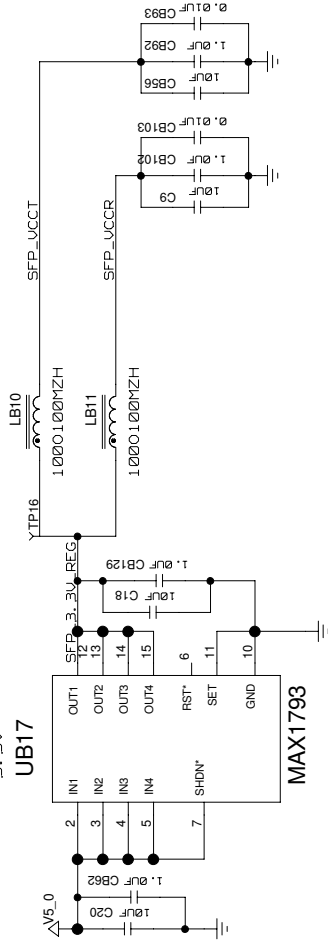

TOP Level Hierarchy
 TITLE: MAX24287 EVB
 ENGINEER: Steve Sol

3

4

5

6

7

8

8 7 6 5 4 3

JUMPER 1+3, 4+6 TO POWER FROM USB ONLY

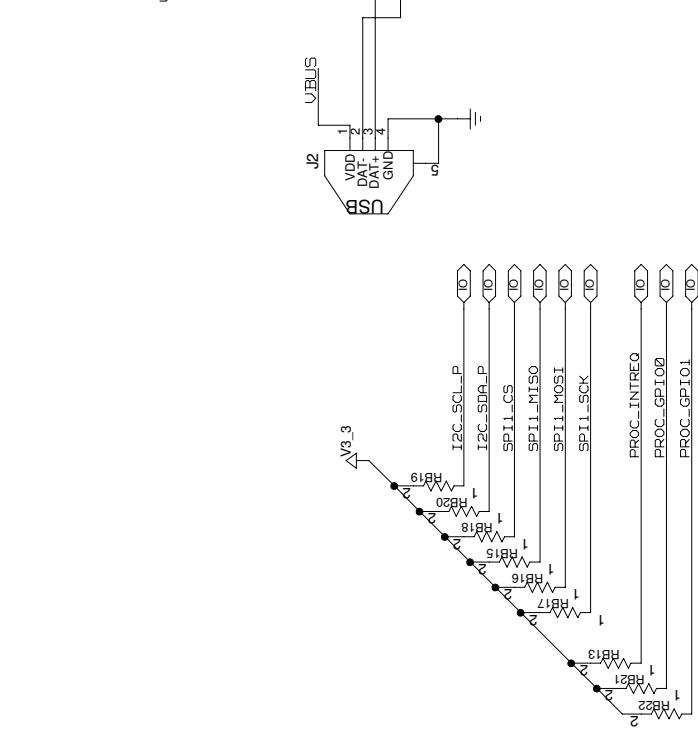
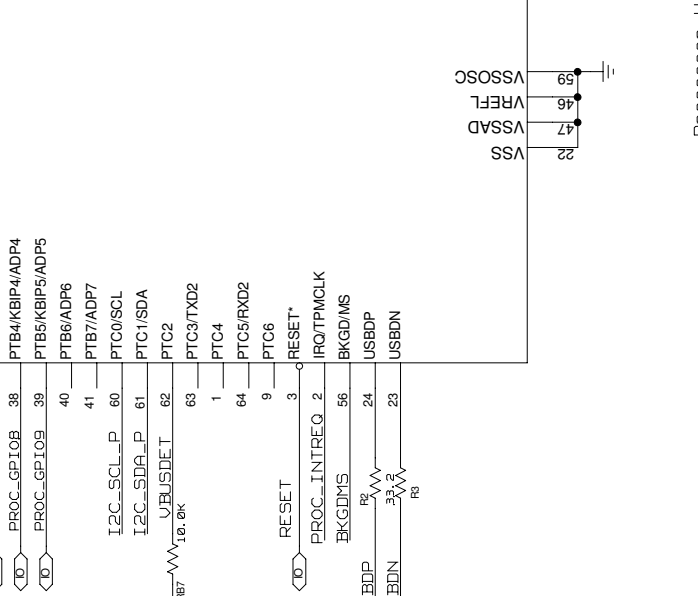
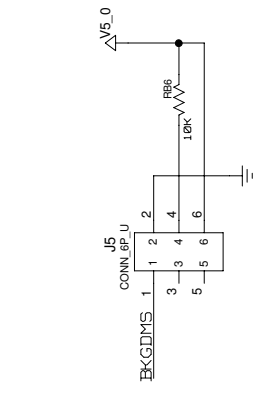
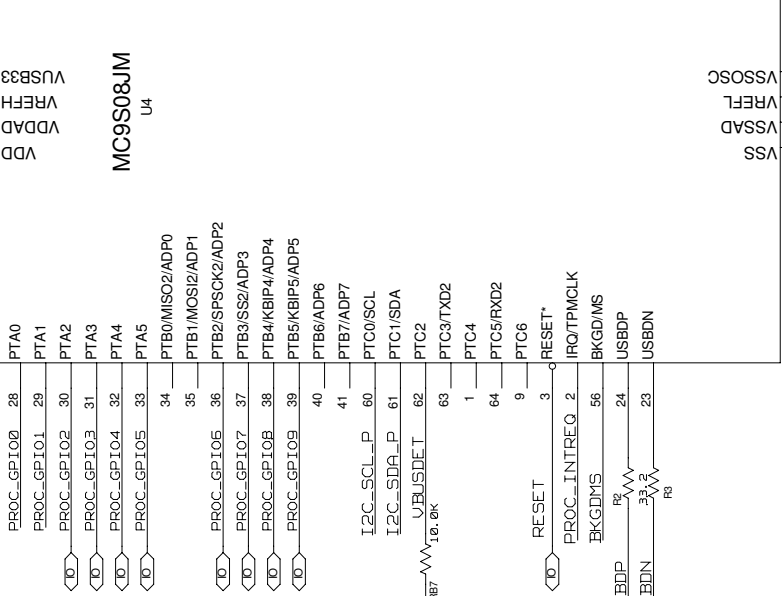
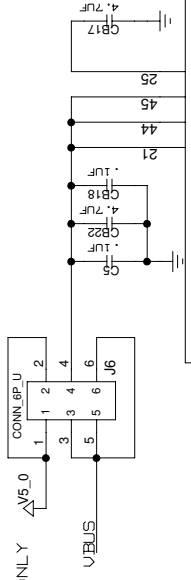

Processor Hierarchy
TITLE: MAX24287 EVU
ENGINEER: Steve Sc...

MOUNTING HARDWARE
H1 H2 H3 H4 H5 H6 H7

8 7 6 5 4 3

1K PULLUPS

J31

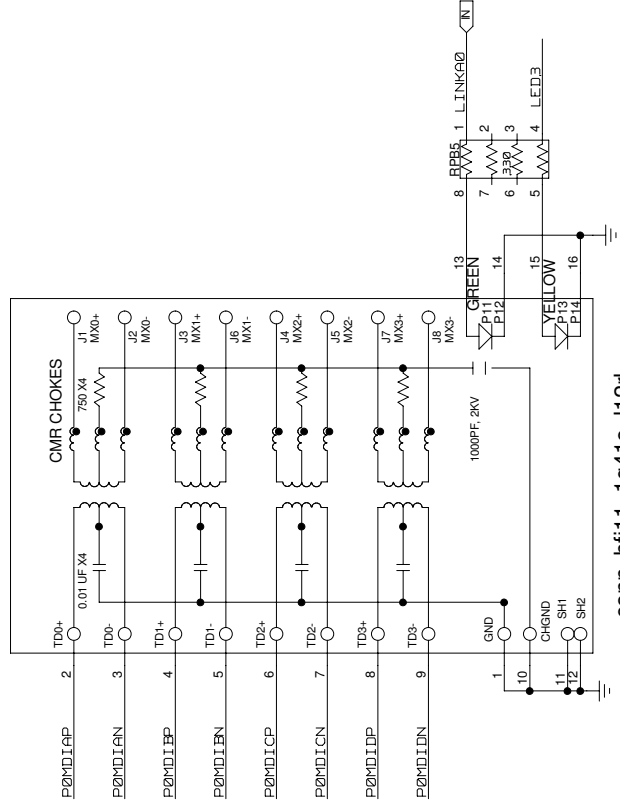

conn_hfj11_1g41e_1j21r

J29

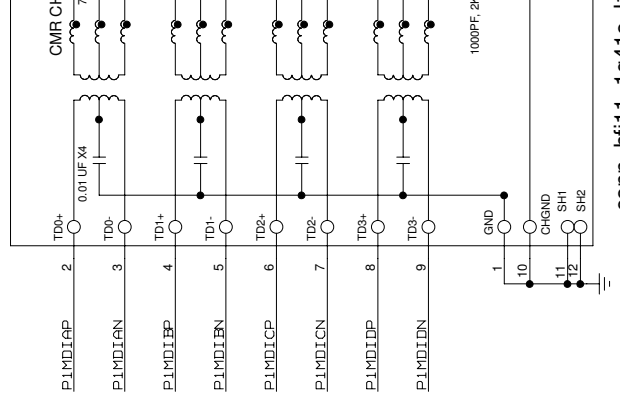

conn_hfj11_1g41e_1j21r

INDICATIONS FOR PARALLEL MODE0

- LED0=G1G-LINK/ACT
- LED1=100-LINK/ACT
- LED2=DUP/COOL
- LED3=DUP/COOL
- LED4=G1G-LINK/ACT
- LED5=100-LINK/ACT
- LED6=DUP/COOL
- LED7=DUP/COOL

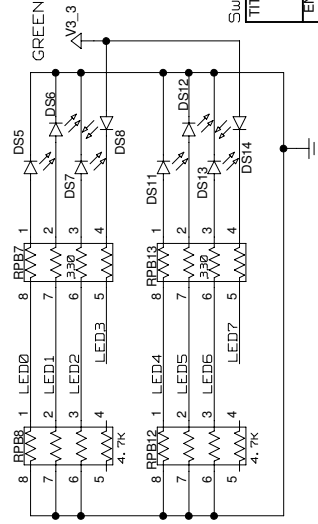

Switch Hierarchy

TITLE: MAX242B7 EVU

ENGINEER: Steve Sol

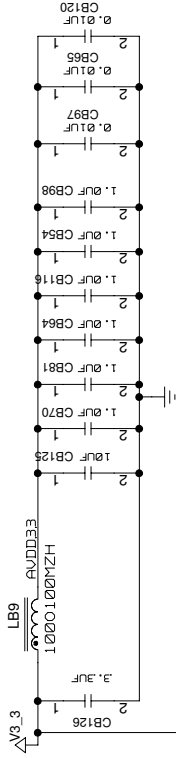

P2IF [2:0] STRAP OPTIONS
 000: GMII/PHY MODE MII
 001: GMII/PHY MODE MII
 010: GMII
 011: RMII

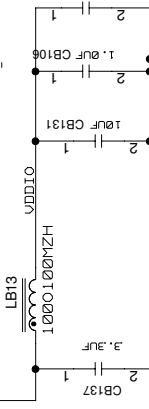
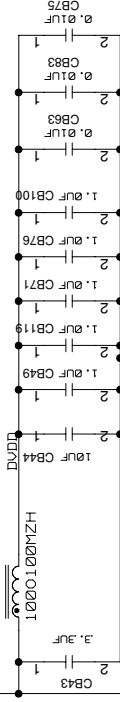
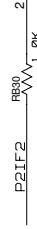

ADD 1.5NS DELAY TO P2MGTXC
 NO DELAY

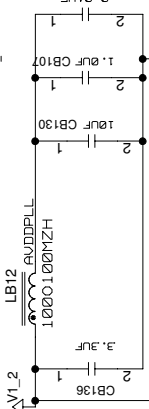

ADD 1.5NS DELAY TO P2MGRXC
 NO DELAY

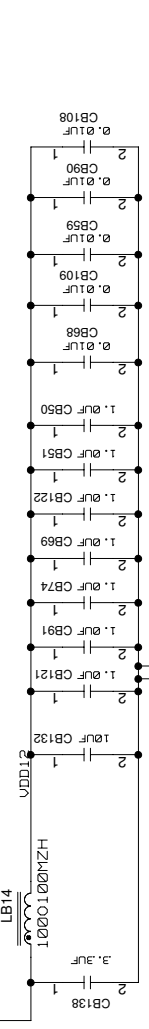
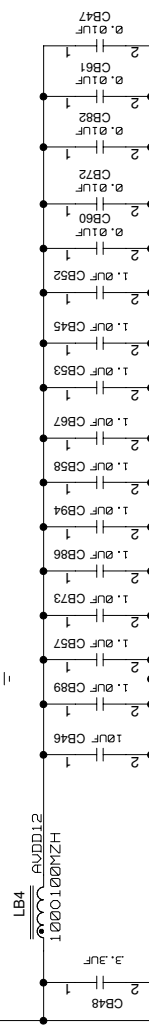

Switch Hierarchy
 TITLE: MAX24287 EVU
 ENGINEER: Steve Sc...



Microsemi Corporate Headquarters
One Enterprise, Aliso Viejo CA 92656 USA
Within the USA: +1 (949) 380-6100
Sales: +1 (949) 380-6136
Fax: +1 (949) 215-4996

Microsemi Corporation (NASDAQ: MSCC) offers a comprehensive portfolio of semiconductor solutions for: aerospace, defense and security; enterprise and communications; and industrial and alternative energy markets. Products include high-performance, high-reliability analog and RF devices, mixed signal and RF integrated circuits, customizable SoCs, FPGAs, and complete subsystems. Microsemi is headquartered in Aliso Viejo, Calif. Learn more at www.microsemi.com.

© 2012 Microsemi Corporation. All rights reserved. Microsemi and the Microsemi logo are trademarks of Microsemi Corporation. All other trademarks and service marks are the property of their respective owners.

Looking for pricing, stock, or lifecycle information?

Click below to explore more details on WIN SOURCE:

- ⊖ [View MAX24188EVKIT# on WIN SOURCE](#)
- ⊖ [Microsemi Corporation](#) Information

Optimize Your Supply Chain with WIN SOURCE Solutions

- ✓ Global Sourcing Solution
- ✓ Obsolete Management
- ✓ Cost Control Management
- ✓ Shortage Management
- ✓ Alternative Solution
- ✓ Excess Inventory Management