



Click [here](#) for production status of specific part numbers.

## MAX17220–MAX17225

## 400mV to 5.5V Input, nanoPower Synchronous Boost Converter with True Shutdown

### General Description

The MAX17220–MAX17225 is a family of ultra-low quiescent current boost (step-up) DC-DC converters with a 225mA/0.5A/1A peak inductor current limit and True Shutdown™. True Shutdown disconnects the output from the input with no forward or reverse current. The output voltage is selectable using a single standard 1% resistor. The 225mA (MAX17220), 500mA (MAX17222/MAX17223), and 1A (MAX17224/MAX17225) peak inductor current limits allow flexibility when choosing inductors. The MAX17220/MAX17222/MAX17224 versions have post-startup enable transient protection (ETP), allowing the output to remain regulated for input voltages down to 400mV, depending on load current. The MAX17220–MAX17225 offer ultra-low quiescent current, small total solution size, and high efficiency throughout the entire load range. The MAX17220–MAX17225 are ideal for battery applications where long battery life is a must.

### Applications

- Optical Heart-Rate Monitoring (OHRM) LED Drivers
- Supercapacitor Backup for RTC/Alarm Buzzers
- Primary-Cell Portable Systems
- Tiny, Low-Power IoT Sensors
- Secondary-Cell Portable Systems
- Wearable Devices
- Battery-Powered Medical Equipment
- Low-Power Wireless Communication Products

**Ordering Information** appears at end of data sheet.

*True Shutdown is a trademark of Maxim Integrated Products, Inc.*

### Benefits and Features

- 300nA Quiescent Supply Current Into OUT
- True Shutdown Mode
  - 0.5nA Shutdown Current
  - Output Disconnects from Input
  - No Reverse Current with  $V_{OUT}$  0V to 5V
- 95% Peak Efficiency
- 400mV to 5.5V Input Range
- 0.88V Minimum Startup Voltage
  - 100mV/Step
  - Single 1% Resistor Selectable Output
- 225mA, 500mA, and 1A Peak Inductor Current Limit
  - MAX17220: 225mA  $I_{LIM}$
  - MAX17222/MAX17223: 500mA  $I_{LIM}$
  - MAX17224/MAX17225: 1A  $I_{LIM}$
- MAX17220/MAX17222/MAX17224 Enable Transient Protection (ETP)
- 2mm x 2mm 6-Pin  $\mu$ DFN
- 0.88mm x 1.4mm 6-Bump WLP (2 x 3, 0.4mm Pitch)

### Typical Operating Circuit

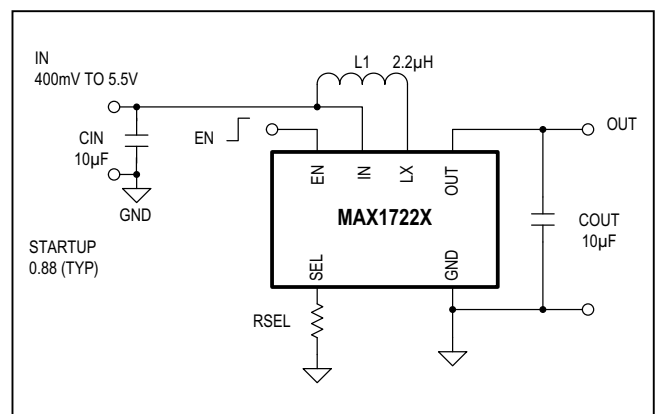

### Absolute Maximum Ratings

OUT, EN, IN to GND .....	-0.3V to +6V	Continuous Power Dissipation (T <sub>A</sub> = 70°C)	
RSEL to GND .....	-0.3V to Lower of (V <sub>OUT</sub> + 0.3V) or 6V	μDFN (derate 4.5mW/°C above +70°C).....	357.8mW
LX RMS Current WLP .....	-1.6A <sub>RMS</sub> to +1.6A <sub>RMS</sub>	Operating Temperature Range.....	-40°C to +125°C
LX RMS Current μDFN .....	-1A <sub>RMS</sub> to +1A <sub>RMS</sub>	Junction Temperature.....	+150°C
Continuous Power Dissipation (T <sub>A</sub> = 70°C)		Storage Temperature Range.....	-40°C to +150°C
WLP (derate 10.5mW/°C above +70°C).....	840mW	Soldering Temperature (reflow).....	+260°C

Stresses beyond those listed under "Absolute Maximum Ratings" may cause permanent damage to the device. These are stress ratings only, and functional operation of the device at these or any other conditions beyond those indicated in the operational sections of the specifications is not implied. Exposure to absolute maximum rating conditions for extended periods may affect device reliability.

### Package Information

#### μDFN

PACKAGE CODE	L622+1C
Outline Number	<a href="#">21-0164</a>
Land Pattern Number	<a href="#">90-0004</a>
<b>Thermal Resistance, Four-Layer Board:</b>	
Junction to Ambient (θ <sub>JA</sub> )	223.6°C/W
Junction to Case (θ <sub>JC</sub> )	122°C/W

#### WLP

PACKAGE CODE	N60E1+1
Outline Number	<a href="#">21-100128</a>
Land Pattern Number	<a href="#">Refer to Application Note 1891</a>
<b>Thermal Resistance, Four-Layer Board:</b>	
Junction to Ambient (θ <sub>JA</sub> )	95.15°C/W
Junction to Case (θ <sub>JC</sub> )	N/A

For the latest package outline information and land patterns (footprints), go to [www.maximintegrated.com/packages](http://www.maximintegrated.com/packages). Note that a "+", "#", or "-" in the package code indicates RoHS status only. Package drawings may show a different suffix character, but the drawing pertains to the package regardless of RoHS status.

Package thermal resistances were obtained using the method described in JEDEC specification JESD51-7, using a four-layer board. For detailed information on package thermal considerations, refer to [www.maximintegrated.com/thermal-tutorial](http://www.maximintegrated.com/thermal-tutorial).

## Electrical Characteristics

( $V_{IN} = V_{EN} = 1.5V$ ,  $V_{OUT} = 3V$ ,  $T_A = -40^{\circ}C$  to  $+125^{\circ}C$ , typical values are at  $T_A = +25^{\circ}C$ , unless otherwise noted. (Note 1))

PARAMETER	SYMBOL	CONDITIONS		MIN	TYP	MAX	UNITS	
Minimum Input Voltage	$V_{IN\_MIN}$	Runs from output after startup, $I_{OUT} = 1mA$			400		mV	
Input Voltage Range	$V_{IN}$	Guaranteed by LX Maximum On-Time		0.95		5.5	V	
Minimum Startup Input Voltage	$V_{IN\_STARTUP}$	$R_L \geq 3k\Omega$ , Typical Operating Circuit, $T_A = 25^{\circ}C$			0.88	0.95	V	
Output Voltage Range	$V_{OUT}$	See RSEL Selection table. For $V_{IN} < V_{OUT}$ target (Note 2)		1.8		5	V	
Output Accuracy, LPM	ACC <sub>LPM</sub>	$V_{OUT}$ falling, when LX switching frequency is $> 1MHz$ (Note 3)		-1.5		+1.5	%	
Output Accuracy, Ultra-Low-Power Mode	ACC <sub>ULPM</sub>	$V_{OUT}$ falling, when LX switching frequency is $> 1kHz$ (Note 4)		1	2.5	4	%	
Quiescent Supply Current Into OUT	$I_{Q\_OUT}$	MAX17220/2/4 EN = open after startup, MAX17223/5 EN = $V_{IN}$ , not switching, RSEL OPEN, $V_{OUT} = 104\%$ of 1.8V	$T_A = 25^{\circ}C$ .		300	600	nA	
		MAX17220/2/4 EN = open after startup, MAX17223/5 EN = $V_{IN}$ , not switching, RSEL OPEN, $V_{OUT} = 104\%$ of 1.8V	$T_A = 85^{\circ}C$		470	900		
		MAX17220/2/4 EN = open after startup MAX17223/5 EN = $V_{IN}$ , not switching, RSEL OPEN, $V_{OUT} = 104\%$ of 1.8V	$T_A = 125^{\circ}C$		1000	2000		
Quiescent Supply Current Into IN	$I_{Q\_IN}$	$T_A = 25^{\circ}C$			0.1		nA	
Total Quiescent Supply Current into IN LX EN	$I_{Q\_IN\_TOTAL}$	MAX17220/2/4 EN = Open after startup. MAX17223/5 EN = $V_{IN}$ , not switching, $V_{OUT} = 104\%$ of $V_{OUT}$ target, total current includes IN, LX, and EN, $T_A = 25^{\circ}C$			0.5	100	nA	
Shutdown Current Into IN	$I_{SD\_IN}$	MAX17220/2/3/4/5, $R_L = 3k\Omega$ , $V_{OUT} = V_{EN} = 0V$ , $T_A = 25^{\circ}C$			0.1		nA	
Total Shutdown Current into IN LX	$I_{SD\_TOTAL}$	MAX17220/2/3/4/5, $R_L = 3k\Omega$ , $V_{EN} = V_{IN} = V_{LX} = 3V$ , includes LX and IN leakage, $T_A = 25^{\circ}C$			0.5	100	nA	
Inductor Peak Current Limit	$I_{PEAK}$	(Note 5)	MAX17220	180	225	270	mA	
			MAX17222/3	0.4	0.5	0.575		A
			MAX17224/5	0.8	1	1.2		
LX Maximum Duty Cycle	DC	(Note 6)		70	75		%	
LX Maximum On-Time	$t_{ON}$	(Note 6)	$V_{OUT} = 1.8V$	280	365	450	ns	
			$V_{OUT} = 3V$	270	300	330		

## Electrical Characteristics (continued)

(V<sub>IN</sub> = V<sub>EN</sub> = 1.5V, V<sub>OUT</sub> = 3V, T<sub>A</sub> = -40°C to +125°C, typical values are at T<sub>A</sub> = +25°C, unless otherwise noted. (Note 1))

PARAMETER	SYMBOL	CONDITIONS	MIN	TYP	MAX	UNITS	
LX Minimum Off-Time	t <sub>OFF</sub>	(Note 6)	V <sub>OUT</sub> = 1.8V	90	120	150	ns
			V <sub>OUT</sub> = 3V	80	100	120	
LX Leakage Current	I <sub>LX_LEAK</sub>	V <sub>OUT</sub> = V <sub>EN</sub> = 0V, MAX17220	V <sub>LX</sub> = 1.5V, T <sub>A</sub> = 25°C	0.3		nA	
			V <sub>LX</sub> = 5.5V, T <sub>A</sub> = 85°C	30			
			V <sub>LX</sub> = 5.5V, T <sub>A</sub> = 125°C	400			
N-Channel On-Resistance	R <sub>DS(ON)</sub>	V <sub>OUT</sub> = 3.3V	MAX17220	124	270	mΩ	
			MAX17222/3	62	135		
			MAX17224/5	31	70		
P-Channel On-Resistance	R <sub>DS(ON)</sub>	V <sub>OUT</sub> = 3.3V	MAX17220	300	600	mΩ	
			MAX17222/3	150	300		
			MAX17224/5	75	150		
Synchronous Rectifier Zero-Crossing as Percent of Peak Current Limit	I <sub>ZX</sub>	V <sub>OUT</sub> = 3.3V (Note 7)	2.5	5	7.5	%	
Enable Voltage Threshold	V <sub>IL</sub>	When LX switching stops, EN falling, T <sub>A</sub> = -40°C to +85°C	250	500		mV	
		When LX switching stops, EN falling, T <sub>A</sub> = -40°C to +125°C	150				
	V <sub>IH</sub>	EN rising, T <sub>A</sub> = -40°C to +85°C	600		850		
		EN rising, T <sub>A</sub> = -40°C to +125°C			900		
Enable Input Leakage	I <sub>EN_LK</sub>	MAX17223/5, V <sub>EN</sub> = 5.5V, T <sub>A</sub> = 25°C	0.1		nA		
		MAX17220/2/4, V <sub>EN</sub> = 0V, T <sub>A</sub> = 25°C,	0.1				
Enable Input Impedance		MAX17220/2/4	100	200	kΩ		
Required Select Resistor Accuracy	R <sub>SEL</sub>	Use the nearest ±1% resistor from R <sub>SEL</sub> Selection Table	-1	+1		%	
Select Resistor Detection Time	t <sub>RSEL</sub>	V <sub>OUT</sub> = 1.8V, C <sub>RSEL</sub> < 2pF (Note 8)	360	600	1320	μs	

**Note 1:** Limits are 100% production tested at T<sub>A</sub> = +25°C. Limits over the operating temperature range are guaranteed through correlation using statistical quality control (SQC) methods.

**Note 2:** Guaranteed by the Required Select Resistor Accuracy parameter.

**Note 3:** Output Accuracy, Low Power mode is the regulation accuracy window expected when I<sub>OUT</sub> > I<sub>OUT\_TRANSITION</sub>. See [PFM Control Scheme](#) and V<sub>OUT</sub> ERROR vs I<sub>LOAD</sub> TOC for more details. This accuracy does not include load, line, or ripple.

**Note 4:** Output Accuracy, Ultra-Low Power mode is the regulation accuracy window expected when I<sub>OUT</sub> < I<sub>OUT\_TRANSITION</sub>. See [PFM Control Scheme](#) and V<sub>OUT</sub> ERROR vs. I<sub>LOAD</sub> TOC for more details. This accuracy does not include load, line, or ripple.

**Note 5:** This is a static measurement. See I<sub>LIM</sub> vs. V<sub>IN</sub> TOC. The actual peak current limit depends upon V<sub>IN</sub> and L due to propagation delays.

**Note 6:** Guaranteed by measuring LX frequency and duty cycle

**Note 7:** This is a static measurement.

**Note 8:** This is the time required to determine R<sub>SEL</sub> value. This time adds to the startup time. See [Output Voltage Selection](#).

Typical Operating Characteristics

(MAX17222ELT+, IN = 1.5V, OUT = 3V, L = 2.2μH Coilcraft XFL4020-222, C<sub>IN</sub> = 10μF, C<sub>OUT</sub> = 10μF, T<sub>A</sub> = +25°C, unless otherwise noted.)

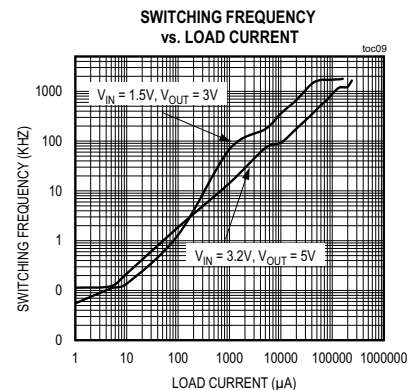
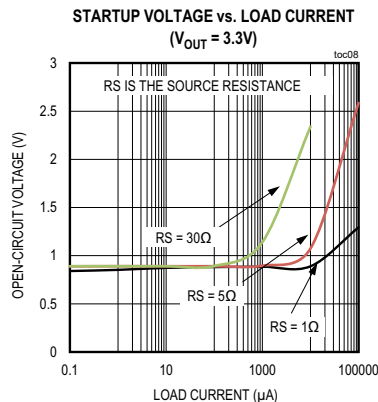
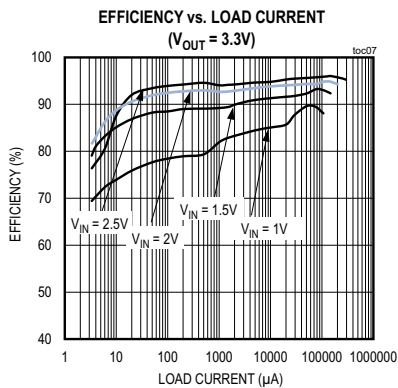
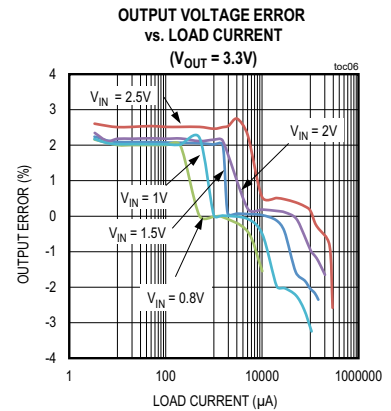
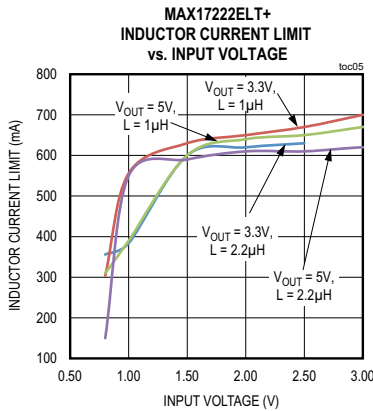
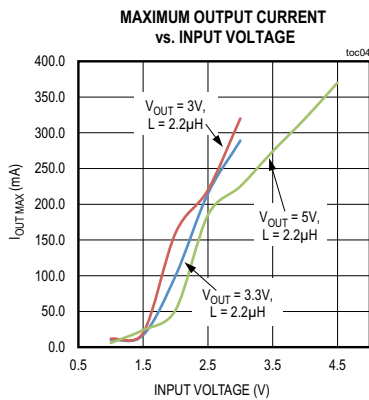
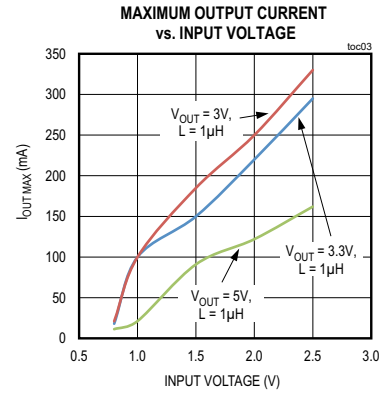
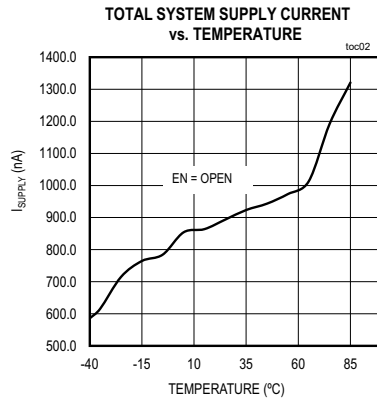
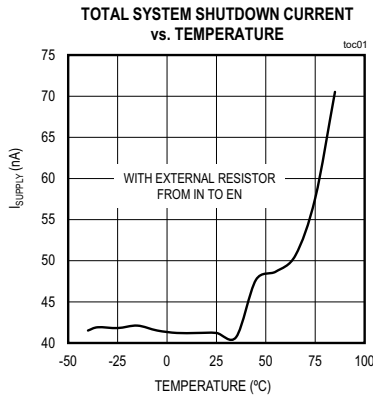

Typical Operating Characteristics (continued)

(MAX17222ELT+, IN = 1.5V, OUT = 3V, L = 2.2μH Coilcraft XFL4020-222, C<sub>IN</sub> = 10μF, C<sub>OUT</sub> = 10μF, T<sub>A</sub> = +25°C, unless otherwise noted.)

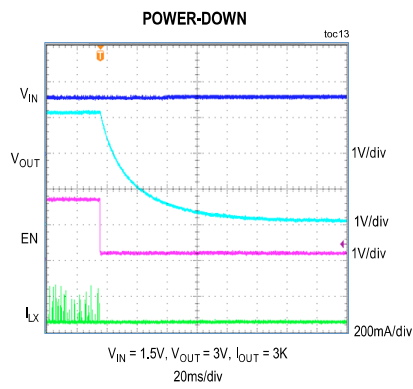
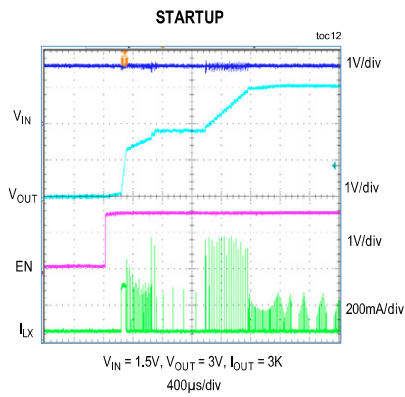
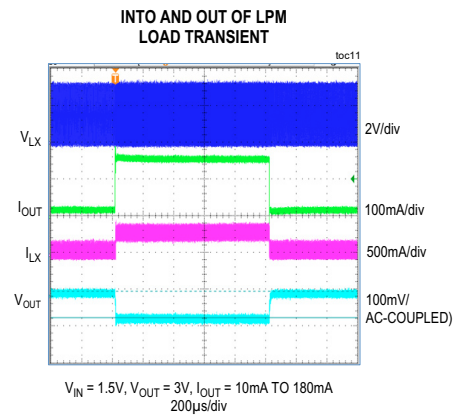
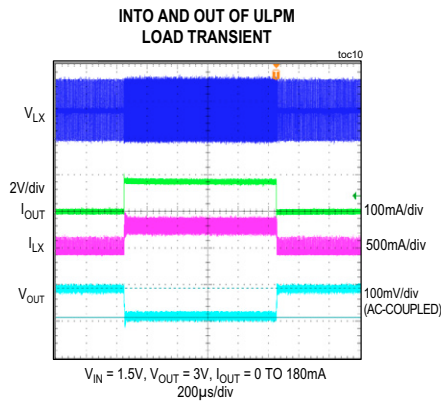

Typical Operating Characteristics (continued)

(MAX17222ELT+,  $V_{IN} = 1.5V$ ,  $V_{OUT} = 3V$ ,  $L = 2.2\mu H$  Coilcraft XFL4020-222,  $C_{IN} = 10\mu F$ ,  $C_{OUT} = 10\mu F$ ,  $T_A = +25^\circ C$ , unless otherwise noted.)

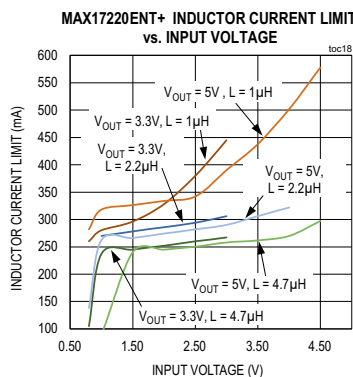
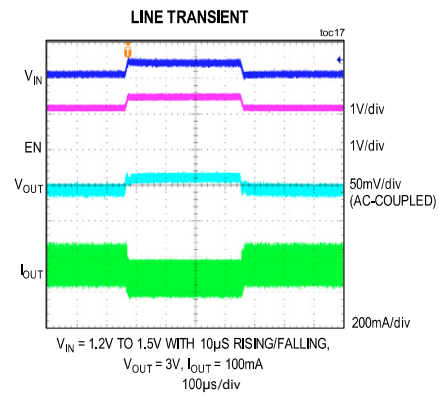
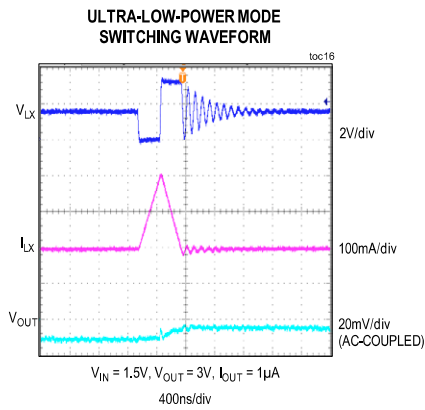
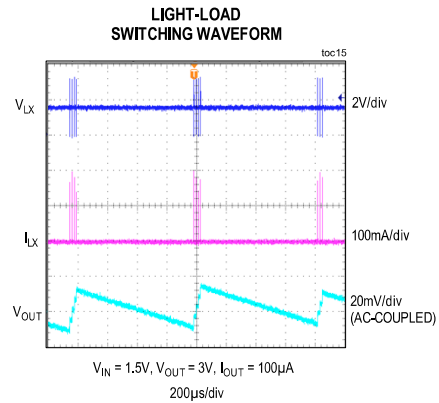
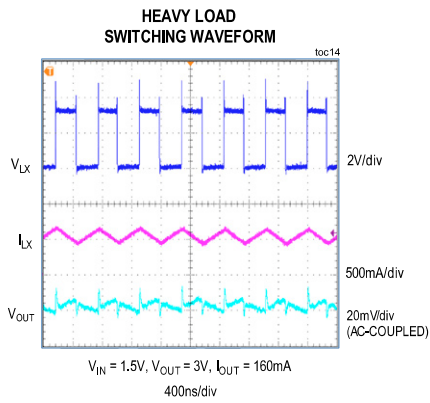

### Bump Configuration

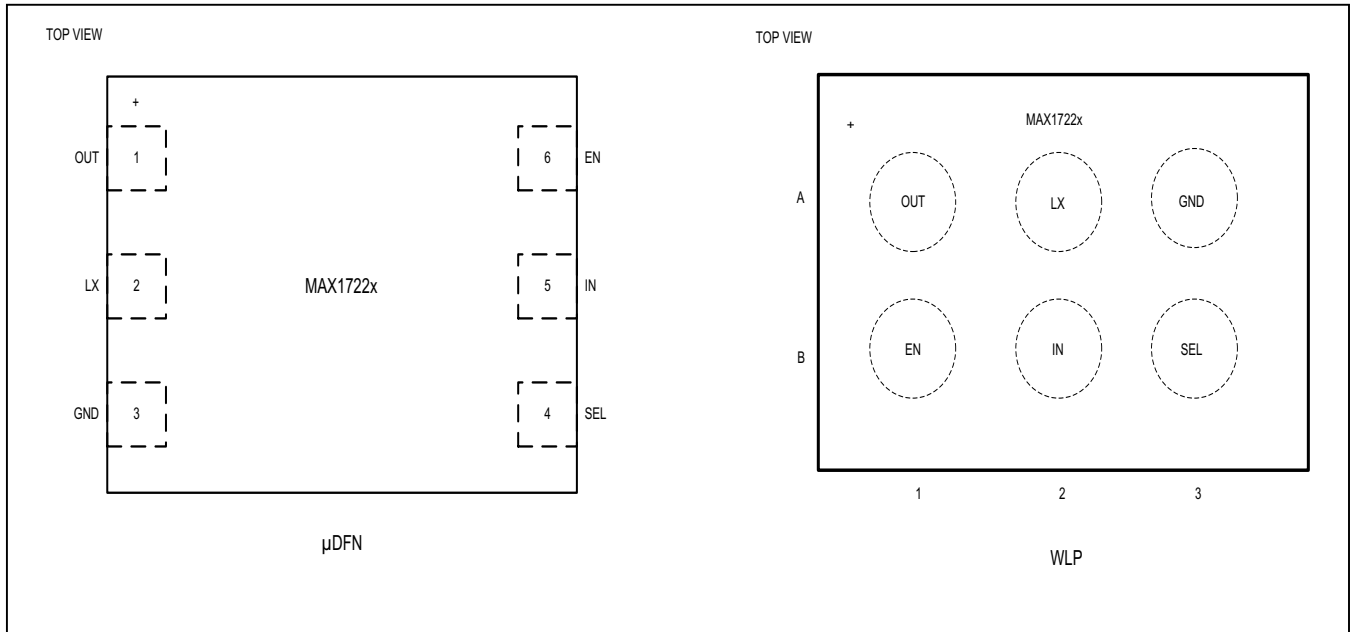

### Bump Description

PIN		NAME	FUNCTION
6 WLP	$\mu$ DFN		
A1	1	OUT	Output Pin. Connect a 10 $\mu$ F X5R ceramic capacitor (minimum 2 $\mu$ F capacitance) to ground.
A2	2	LX	Switching Node Pin. Connect the inductor from IN to LX.
A3	3	GND	Ground Pin.
B1	6	EN	Active-High Enable Input. See <i>Supply Current</i> section for recommended connections.
B2	5	IN	Input Pin. Connect a 10 $\mu$ F X5R ceramic capacitor (minimum 2 $\mu$ F capacitance) to ground. Depending on the application requirements, more capacitance may be needed (i.e., BLE).
B3	4	SEL	Output Voltage Select Pin. Connect a resistor from SEL to GND based on the desired output voltage. See <i>RSEL Selection</i> table.

Functional Diagrams

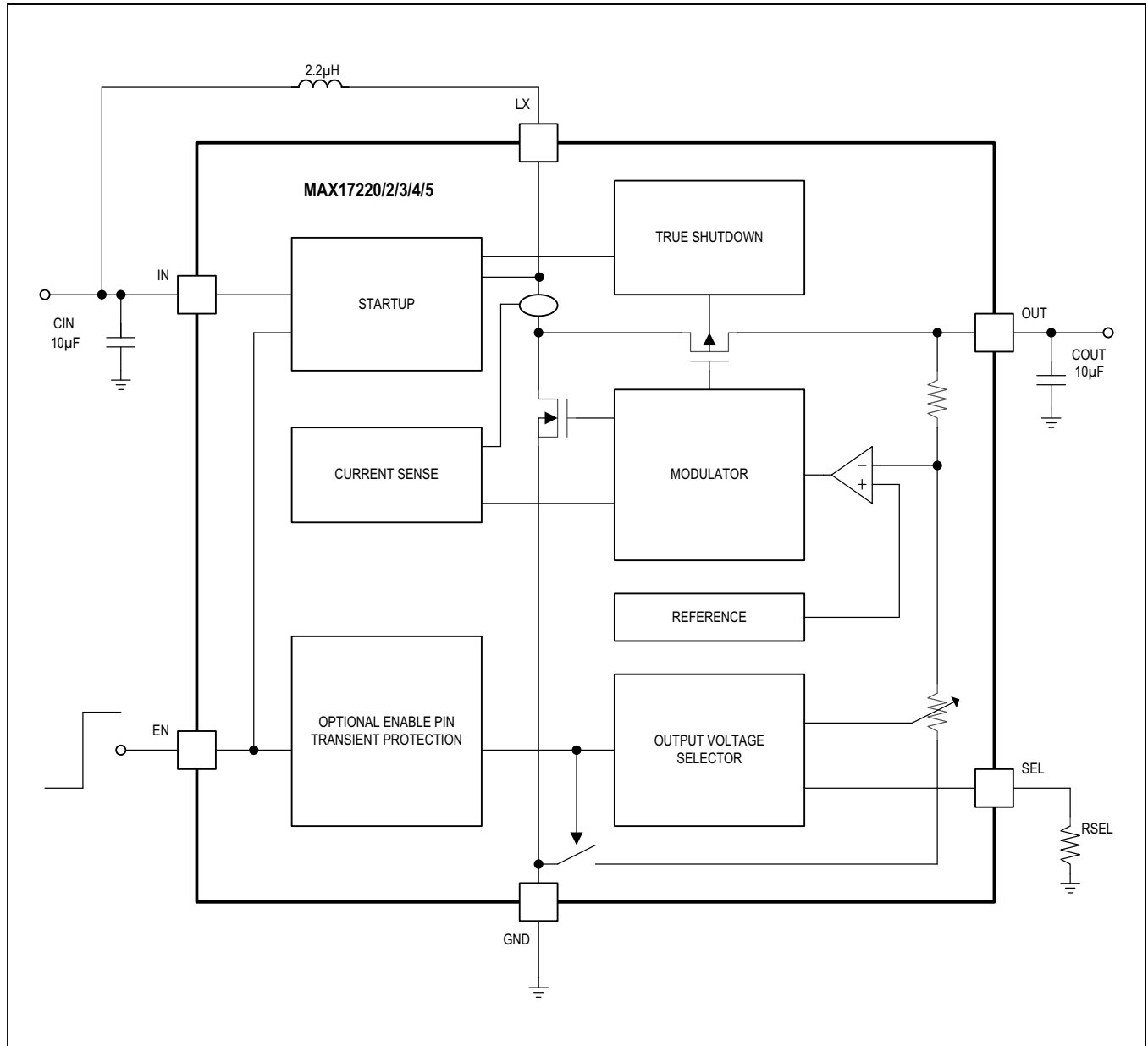

### Detailed Description

The MAX17220/2/3/4/5 compact, high-efficiency, step-up DC-DC converters have ultra-low quiescent current, are guaranteed to start up with voltages as low as 0.95V, and operate with an input voltage down to 400mV, depending on load current. True Shutdown disconnects the input from the output, saving precious battery life. Every detail of the MAX17220/2/3/4/5 was carefully chosen to allow for the lowest power and smallest solution size. Such details as switching frequencies up to 2.5MHz, tiny package options, a single-output setting resistor, 300ns fixed turn-on time, as well as three current limit options, allow the user to minimize the total solution size.

### Supply Current

#### True Shutdown Current

The total system shutdown current ( $I_{SD\_TOTAL\_SYSTEM}$ ) is made up of the MAX17220/2/3/4/5's total shutdown current ( $I_{SD\_TOTAL}$ ) and the current through an external pullup resistor, as shown in Figure 1.  $I_{SD\_TOTAL}$  is listed in the [Electrical Characteristics](#) table and is typically 0.5nA. It is important to note that  $I_{SD\_TOTAL}$  includes LX and IN leakage currents. (See the Shutdown Supply Current vs. Temperature graph in the [Typical Operating Characteristics](#) section.)  $I_{SD\_TOTAL\_SYSTEM}$  current can be calculated using the formula below. For example, for the MAX17220/2/3/4/5 with EN connected to an open-drain GPIO of a microcontroller, a  $V_{IN} = 1.5V$ ,  $V_{OUT} = 3V$ , and a 33M $\Omega$  pullup resistor,  $I_{SD\_TOTAL\_SYSTEM}$  current is 45.9nA.

$$I_{SD\_TOTAL\_SYSTEM} = I_{SD\_TOTAL} + \frac{V_{IN}}{R_{PULLUP}}$$

$$= 0.5nA + \frac{1.5}{33M\Omega} = 45.9nA, \text{ (Figure 1)}$$

Figure 2 shows a typical connection of the MAX17223/5 to a push-pull microcontroller GPIO.  $I_{SD\_TOTAL\_SYSTEM}$  current can be calculated using the formula below. For example, a MAX17223/5 with EN connected to a push-pull microcontroller GPIO,  $V_{IN} = 1.5V$ , and  $V_{OUT} = 3V$ ,  $I_{SD\_TOTAL\_SYSTEM}$  current is 0.5nA.

$$I_{SD\_TOTAL\_SYSTEM} = I_{SD\_TOTAL} = 0.5nA$$

(Figure 2, Figure 3)

Figure 3 shows a typical connection of the MAX17220/2/4 with a push-button switch to minimize the  $I_{SD\_TOTAL\_SYSTEM}$  current.  $I_{SD\_TOTAL\_SYSTEM}$  current can be calculated using the formula above. For example, a MAX17220/2/4 with EN connected as shown in Figure 3, with  $V_{IN} = 1.5V$  and  $V_{OUT} = 3V$ , the  $I_{SD\_TOTAL\_SYSTEM}$  current is 0.5nA.

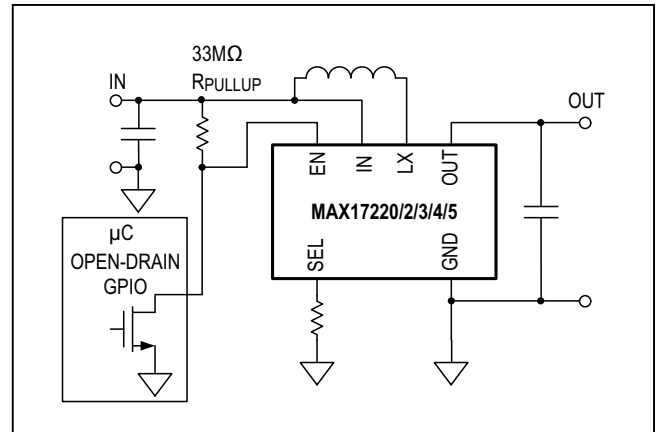

Figure 1. For All Versions, EN Pin Can Be Driven by an Open-Drain Microcontroller GPIO.

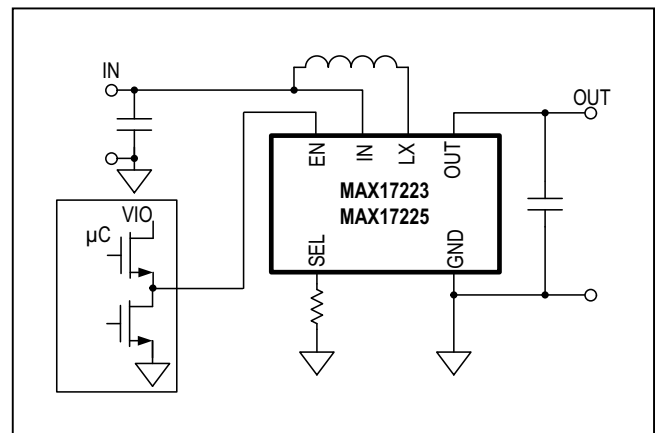

Figure 2. Only the MAX17223/5's EN Pin Can Be Driven by a Push-Pull Microcontroller GPIO.

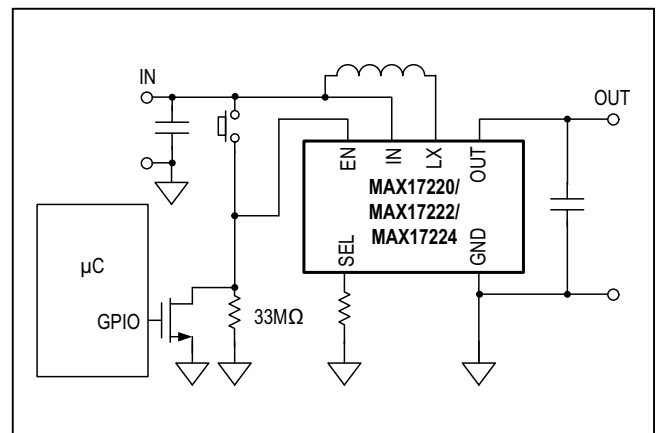

Figure 3. The MAX17220/2/4's Total System Shutdown Current Will Only Be Leakage If Able To Use Push-Button As Shown.

**Enable Transient Protection (ETP) Current**

The MAX17220/2/4 have internal circuitry that helps protect against accidental shutdown by transients on the EN pin. Once the part is started up, these parts allow the voltage at IN to drop as low as 400mV while still keeping the part enabled, depending on the load current. This feature comes at the cost of slightly higher supply current that is dependent on the pullup resistor resistance. The extra supply current for this protection option can be calculated by the equation below. For example, for the MAX17220/2/4 used in the [Figure 1](#) connection, a  $V_{IN} = 1.5V$ ,  $V_{OUT} = 3V$ , a  $33M\Omega$  pullup resistor and an 85% efficiency, the  $I_{Q\_ETP}$  is expected to be 61.3nA.

$$I_{Q\_ETP} = \frac{(V_{OUT} - V_{IN})}{(R_{PULLUP} + 100k)} \times \left( \frac{1}{\eta} \times \frac{V_{OUT}}{V_{IN}} - 1 \right),$$

(Figure1)

$$I_{Q\_ETP} = \frac{(3V - 1.5V)}{(33M + 100k)} \times \left( \frac{1}{0.85} \times \frac{3V}{1.5} - 1 \right) = 61.3nA,$$

(Figure1)

Use the efficiency  $\eta$  from the flat portion of the efficiency typical operating curves while the device is in ultra-low-power mode (ULPM). See the [PFM Control Scheme](#) section for more info on ULPM. Do not use the efficiency for your actual load current. If you are using the versions of the part without enable input transient protection (using MAX17223/5), or if you are using any part version and the electrical path from the EN pin is opened after startup, then there is no  $I_{Q\_ETP}$  current and it will be zero.

$$I_{Q\_ETP} = N/A = 0, \text{ (Figure 2)}$$

$$I_{Q\_ETP} = \frac{(V_{OUT})}{(R_{PULLUP} + 100k)} \times \left( \frac{1}{\eta} \times \frac{V_{OUT}}{V_{IN}} \right),$$

(Figure 3)

$$I_{Q\_ETP} = \frac{(3V)}{(33M + 100k)} \times \left( \frac{1}{0.85} \times \frac{3V}{1.5V} \right) = 213.2nA,$$

(Figure 3)

**Quiescent Current**

The MAX17220/2/3/4/5 has ultra-low quiescent current and was designed to operate at low input voltages by bootstrapping itself from its output by drawing current from the output. Use the equation below to calculate

the total system quiescent current  $I_{Q\_TOTAL\_SYSTEM}$  using the efficiency  $\eta$  from the flat portion of the efficiency graph in the [Typical Operating Characteristics](#) section while the device is in ULPM. See the PFM control scheme section for more info on ULPM. Do not use the efficiency for your actual load current. To calculate the  $I_{Q\_ETP}$  for the MAX17220/2/4, see the [Enable Transient Protection \(ETP\) Current](#) section. If you are using the versions of the part without enable input transient protection (using MAX17223/5) or if you are using any part version and the electrical path from the EN pin is opened after startup, then the  $I_{Q\_ETP}$  current will be zero. For example, for the MAX17223/5, a  $V_{IN} = 1.5V$ ,  $V_{OUT} = 3V$ , and an 85% efficiency, the  $I_{Q\_TOTAL\_SYSTEM}$  is 706.4nA.

$$I_{Q\_TOTAL\_SYSTEM} = I_{Q\_IN\_TOTAL} + \frac{I_{Q\_OUT}}{\eta \times \left( \frac{V_{IN}}{V_{OUT}} \right)}$$

(MAX17223/5)

$$I_{Q\_TOTAL\_SYSTEM} = 0.5nA + \frac{300nA}{0.85 \times \left( \frac{1.5V}{3V} \right)} = 706.4nA,$$

(MAX17223/5)

$$I_{Q\_TOTAL\_SYSTEM} = I_{Q\_IN\_TOTAL} + \frac{I_{Q\_OUT}}{\eta \times \left( \frac{V_{IN}}{V_{OUT}} \right)} + I_{Q\_ETP},$$

(MAX17220/2/4)

$$I_{Q\_TOTAL\_SYSTEM} = 0.5nA + \frac{300nA}{0.85 \times \left( \frac{1.5V}{3V} \right)} + 61.3nA = 767.7nA,$$

(MAX17220/2/4)

**PFM Control Scheme**

The MAX17220/2/3/4/5 utilizes a fixed on-time, current-limited, pulse-frequency-modulation (PFM) control scheme that allows ultra-low quiescent current and high efficiency over a wide output current range. The inductor current is limited by the 0.225A/0.5A/1A N-channel current limit or by the 300ns switch maximum on-time. During each on cycle, either the maximum on-time or the maximum current limit is reached before the off-time of the cycle begins. The MAX17220/2/3/4/5's PFM control scheme allows for both continuous conduction mode (CCM) or discontinuous conduction mode (DCM). When the error comparator senses that the output has fallen below the regulation threshold, another cycle begins. See the MAX17220/2/3/4/5 simplified functional diagram.

The MAX17220/2/3/4/5 automatically switches between the ULPM, low-power mode (LPM) and high-power mode (HPM), depending on the load current. Figure 4 and Figure 5 show typical waveforms while in each mode. The output voltage, by design, is biased 2.5% higher while in ULPM so that it can more easily weather a future

large load transient. ULPM is used when the system is in standby or an ultra-low-power state. LPM and HPM are useful for sensitive sensor measurements or during wireless communications for medium output currents and large output currents respectively. The user can calculate the value of the load current where ULPM transi-

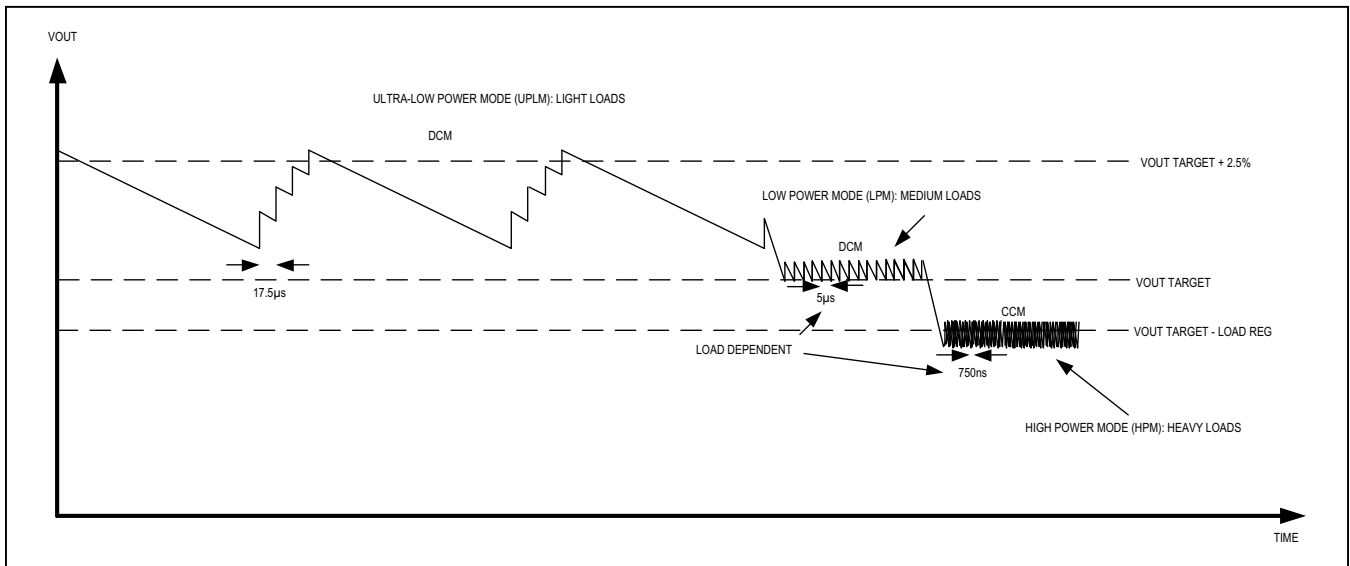

Figure 4. ULPM, LPM, and HPM Waveforms (Part 1).

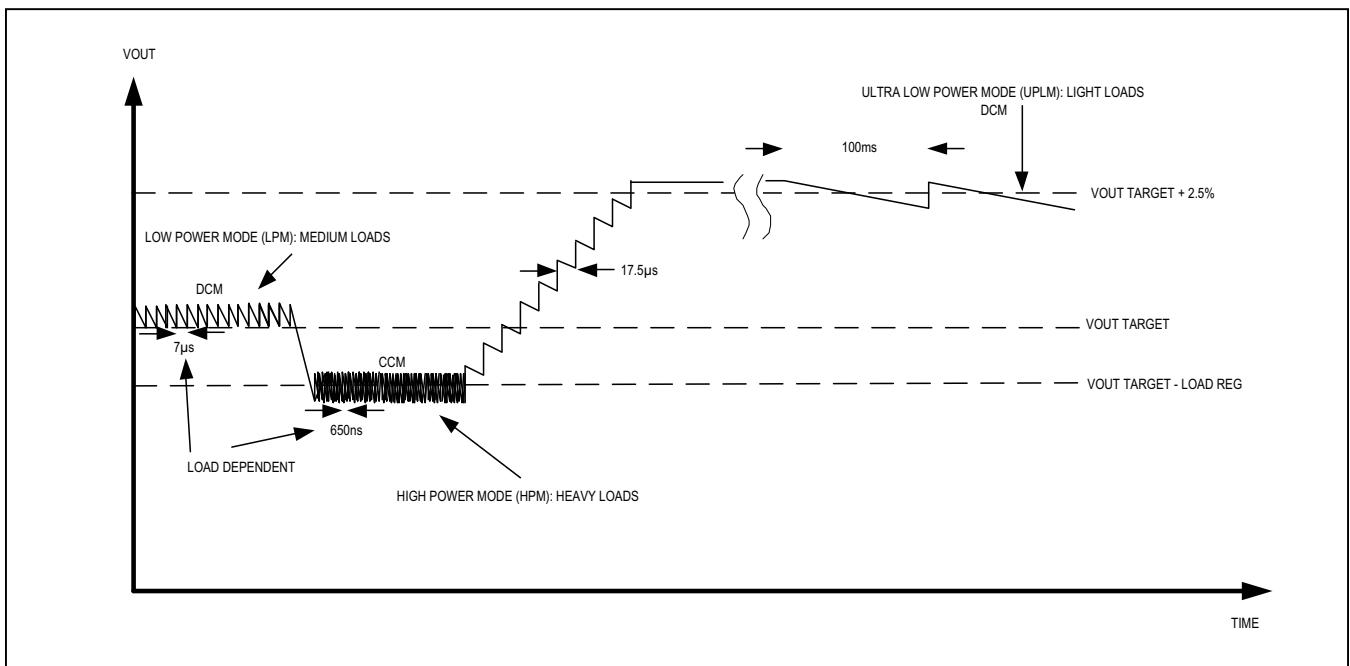

Figure 5. ULPM, LPM, and HPM Waveforms (Part 2).

tions to LPM using the equation below. For example, for  $V_{IN} = 1.5V$ ,  $V_{OUT} = 3V$  and  $L = 2.2\mu H$ , the UPLM to LPM transition current happens at approximately 1.49mA and a no-load frequency of 11.5Hz. The MAX17220/2/3/4/5 enters HPM when the inductor current transitions from DCM to CCM.

$$I_{OUT\_TRANSITION} = \left( \frac{300ns^2}{2L} \right) \times \left( \frac{V_{IN}}{\frac{V_{OUT}}{V_{IN}} - 1} \right) \times \left( \frac{\eta}{17.5\mu s} \right)$$

$$= \left( \frac{300ns^2}{2 \times 2.2\mu H} \right) \times \left( \frac{1.5V}{\frac{3V}{1.5V} - 1} \right) \times \left( \frac{0.85}{17.5\mu s} \right) = 1.49mA$$

The minimum switching frequency can be calculated by this equation below:

$$f_{SW(MIN)} = \frac{1}{17.5\mu s} \times \frac{I_Q}{I_{OUT\_TRANSITION}}$$

$$f_{SW(MIN)} = \frac{1}{17.5\mu s} \times \frac{300nA}{1.49mA} = 11.5Hz$$

### Operation with $V_{IN} > V_{OUT}$

If the input voltage ( $V_{IN}$ ) is greater than the output voltage ( $V_{OUT}$ ) by a diode drop ( $V_{DIODE}$  varies from  $\sim 0.2V$  at light load to  $\sim 0.7V$  at heavy load), then the output voltage is clamped to a diode drop below the input voltage (i.e.,  $V_{OUT} = V_{IN} - V_{DIODE}$ ).

When the input voltage is closer to the output voltage target (i.e.,  $V_{OUT\ target} + V_{DIODE} > V_{IN} > V_{OUT\ target}$ ) the MAX17220–MAX17225 operate like a buck converter.

### Hot Plugging

The MAX17220/2/3/4/5 will initiate a controlled soft start in an event supply voltage is reapplied at high  $dV/dt$  rate;

for example, during installation of a fresh battery. While in regulation if  $V_{IN}$  steps abruptly above  $V_{OUT}$  for more than 1V (typical), the device will reset. Output voltage droop in this case will be a function of the load current, output capacitance and time required for soft start to complete which is 1.5ms typical.

## Design Procedure

### Output Voltage Selection

The MAX17220/2/3/4/5 has a unique single-resistor output selection method known as RSEL, as shown in [Figure 6](#). At startup, the MAX17220/2/3/4/5 uses up to 200 $\mu A$  only during the select resistor detection time, typically for 600 $\mu s$ , to read the RSEL value. RSEL has many benefits, which include lower cost and smaller size, since only one resistor is needed versus the two resistors needed in typical feedback connections. Another benefit is RSEL allows our customers to stock just one part in their inventory system and use it in multiple projects with different output voltages just by changing a single standard 1% resistor. Lastly, RSEL eliminates wasting current continuously through feedback resistors for ultra low power battery operated products. Select the RSEL resistor value by choosing the desired output voltage in the [RSEL Selection Table](#).

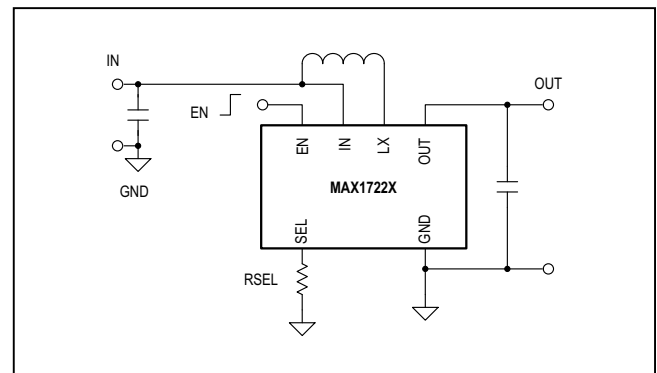

Figure 6. Single RSEL Resistor Sets the Output Voltage.

## RSEL Selection Table

V <sub>OUT</sub> (V)	STD RES 1% (kΩ)
1.8	OPEN
1.9	909
2.0	768
2.1	634
2.2	536
2.3	452
2.4	383
2.5	324
2.6	267
2.7	226
2.8	191
2.9	162
3.0	133
3.1	113
3.2	95.3
3.3	80.6
3.4	66.5
3.5	56.2
3.6	47.5
3.7	40.2
3.8	34
3.9	28
4.0	23.7
4.1	20
4.2	16.9
4.3	14
4.4	11.8
4.5	10
4.6	8.45
4.7	7.15
4.8	5.9
4.9	4.99
5.0	SHORT

## Inductor Selection

A 2.2μH inductor value provides the best size and efficiency tradeoff in most applications. Smaller inductance values typically allow for the smallest physical size and larger inductance values allow for more output current assuming continuous conduction mode (CCM) is achieved. Most applications are expected to use a 2.2μH, as shown in the example circuits. For low input voltages, 1μH will work best. If one of the example application circuits do not provide enough output current, use the equations below to calculate a larger inductance value that meets the output current requirements, assuming it is possible to achieve. For the equations below, choose an I<sub>IN</sub> between 0.9 × I<sub>LIM</sub> and half I<sub>LIM</sub>. It is not recommended to use an inductor value smaller than 1μH or larger than 4.7μH. See the [Typical Operating Characteristics](#) section for choosing the value of efficiency η using the closest conditions for your application. An example calculation has been provided for the MAX17222 that has an I<sub>LIM</sub> = 500mA, a V<sub>IN</sub> (min) = 1.8V, a V<sub>OUT</sub> = 3V, and a desired I<sub>OUT</sub> of 205mA, which is beyond one of the 2.2μH example circuits. The result shows that the inductor value can be changed to 3.3μH to achieve a little more output current.

$$I_{IN} = \frac{V_{OUT} \times I_{OUT}}{\eta \times V_{IN}} = \frac{3V \times 205mA}{0.85 \times 1.8V} = 402mA;$$

$$I_{LIM} < I_{IN} < 0.9 \times I_{LIM}$$

$$\Delta I = (I_{LIM} - I_{IN}) \times 2 = (500mA - 402mA) \times 2 = 196mA$$

$$L_{MIN} = \frac{V_{IN} \times t_{ON(MAX)}}{\Delta I} = \frac{1.8V \times 300ns}{196mA} = 2.76\mu H$$

$$= > 3.3\mu H \text{ closest standard value}$$

## Capacitor Selection

Input capacitors reduce current peaks from the battery and increase efficiency. For the input capacitor, choose a ceramic capacitor because they have the lowest equivalent series resistance (ESR), smallest size, and lowest cost. Choose an acceptable dielectric such as X5R or X7R. Other capacitor types can be used as well but will have larger ESR. The biggest downside of ceramic capacitors is their capacitance drop with higher DC bias and because of this at minimum a standard 10μF ceramic capacitor is recommended at the input for most applications. The minimum recommended capacitance (not capacitor) at the input is 2μF for most applications. For applications that use batteries that have a high source impedance greater than 1Ω, more capacitance may be needed. A good starting point is to use the same capacitance value at the input as for the output.

The minimum output capacitance that ensures stability is 2μF. At minimum a standard 10μF X5R (or X7R) ceramic capacitor is recommended for most applications. Due to DC bias effects the actual capacitance can be 80% lower than the nominal capacitor value. The output ripple can be calculated with the equation below. For example, For the MAX17220/2/3/4/5 with a  $V_{IN} = 1.5V$ ,  $V_{OUT} = 3V$ , and an effective capacitance of 5μF, a capacitor ESR of 4mΩ, the expected ripple is 7mV.

$$V_{RIPPLE} = IL_{PEAK} \times ESR_{COUT} + \frac{1}{2} IL_{PEAK} \times t_{OFF} \times \frac{1}{C_{OUT(Effective)}}$$

Where,

$$IL_{PEAK} = \frac{V_{IN}}{L} \times t_{ON} = \frac{1.5V}{2.2\mu H} \times 300ns = 204mA$$

$$t_{OFF} = t_{ON} \times \left[ \frac{V_{IN}}{V_{OUT} - V_{IN}} \right] = 300ns \times \left[ \frac{1.5V}{3V - 1.5V} \right] = 300ns$$

$C_{OUT}$  (Effective) = 5μF,  $ESR_{COUT}$  for Murata GRM155R61A106ME44 is 4mΩ from 200kHz to 2MHz

$$V_{RIPPLE} = 204mA \times 4m\Omega + \frac{1}{2} 204mA \times 300ns \times \frac{1}{5\mu F} = 7mV$$

### PCB Layout Guidelines

Careful PC board layout is especially important in a nano-current DC-DC converters. In general, minimize trace lengths to reduce parasitic capacitance, parasitic resistance and radiated noise. Remember that every square of 1oz copper will result in 0.5mΩ of parasitic resistance. The connection from the bottom of the output capacitor and the ground pin of the device must be extremely short as should be that of the input capacitor. Keep the main power path from IN, LX, OUT, and GND as tight and short as possible. Minimize the surface area used for LX since this is the noisiest node. Lastly, the trace used for RSEL should not be too long nor produce a capacitance of more than a few pico Farads.

Applications Information

Primary Cell Bluetooth Low Energy (BLE) Temperature Sensor Wearable

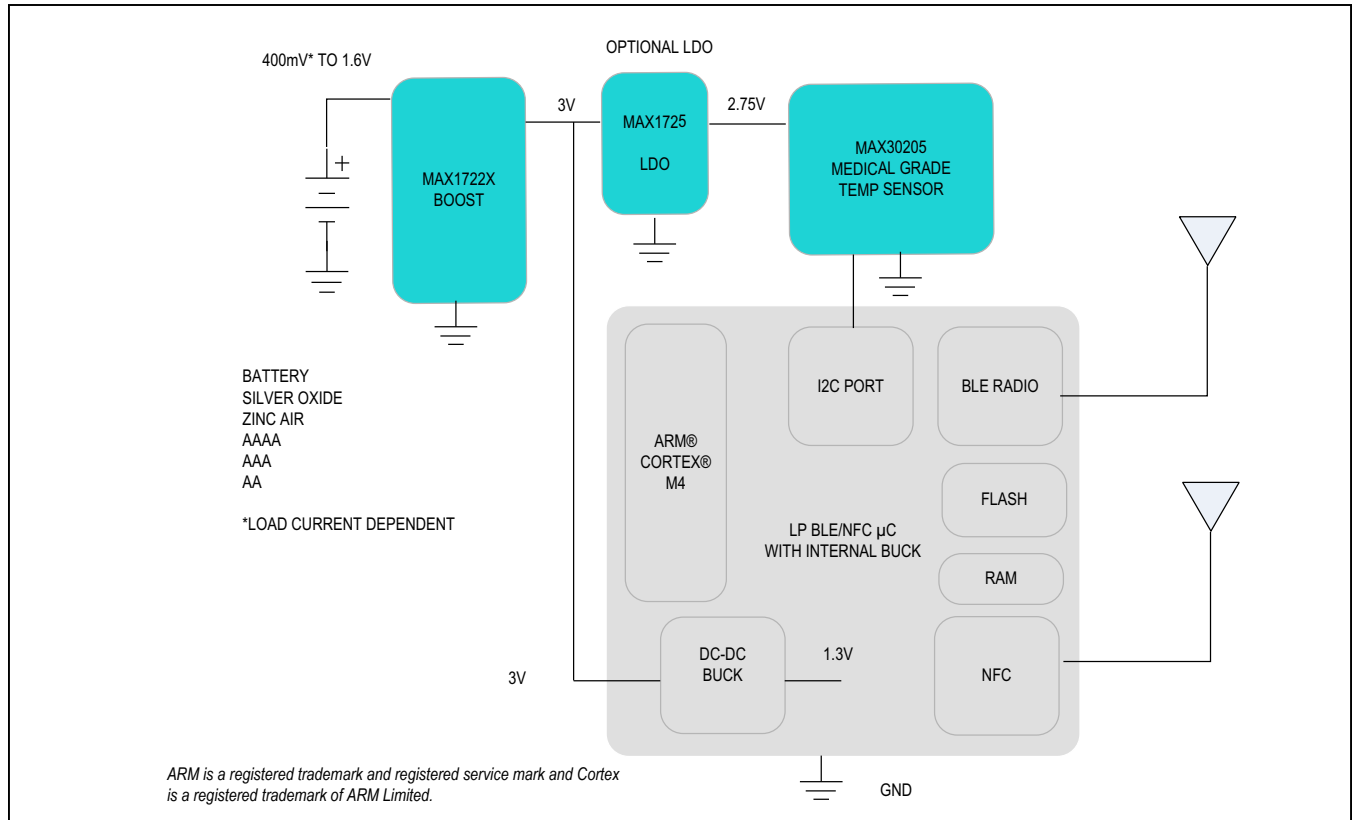

Figure 7. MAX1722x/MAX30205 Temperature Sensor Wearable Solution

Primary Cell Bluetooth Low Energy (BLE) Optical Heart Rate Monitoring (OHRM) Sensor Wearable

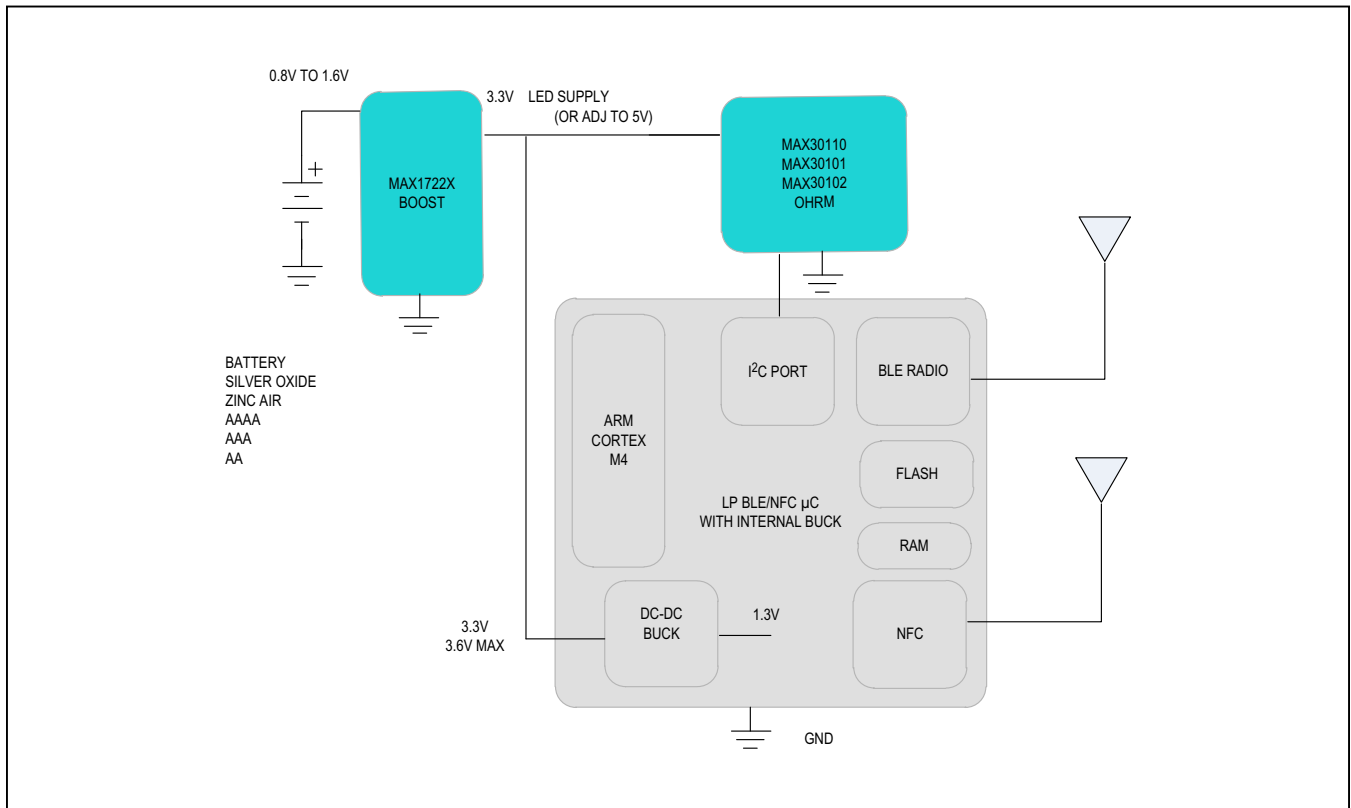

Figure 8. MAX1722x/MAX30110/MAX30101/MAX30102 Optical Heart Rate Monitor (OHRM) Sensor Wearable Solution for Primary Cells.

**Secondary Rechargeable Lithium Cell Bluetooth Low Energy (BLE) Optical Heart Rate Monitor (OHRM) Sensor Wearable**

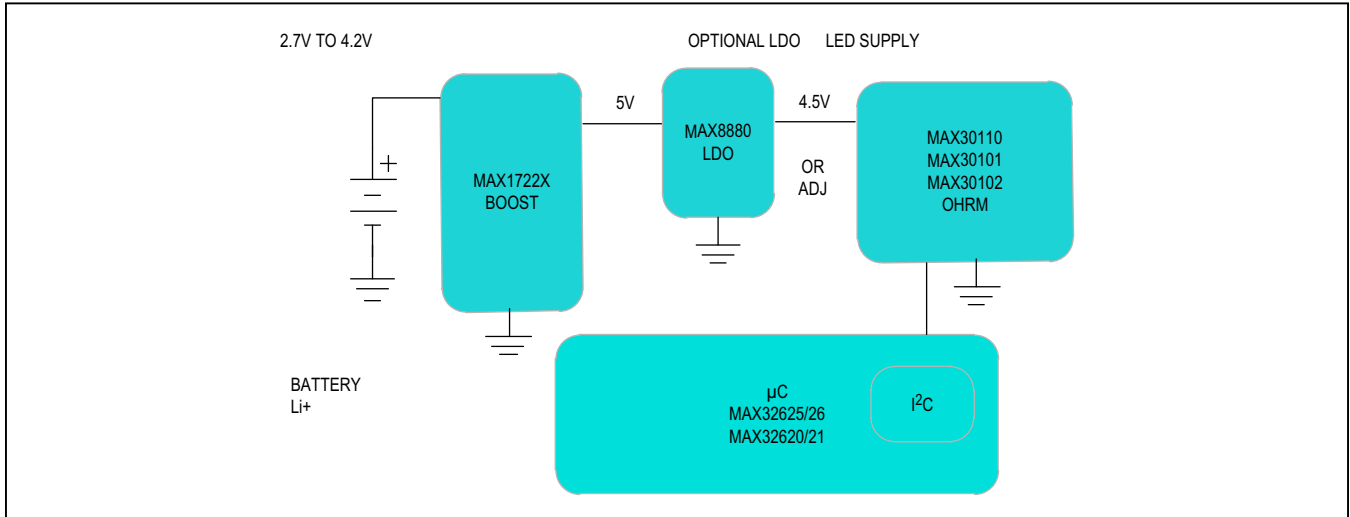

Figure 9. MAX1722x/MAX30110/MAX30101/MAX30102 Optical Heart Rate Monitor (OHRM) Sensor Wearable Solution for Secondary Cells.

**Supercap Backup Solution for Real-Time Clock (RTC) Preservation**

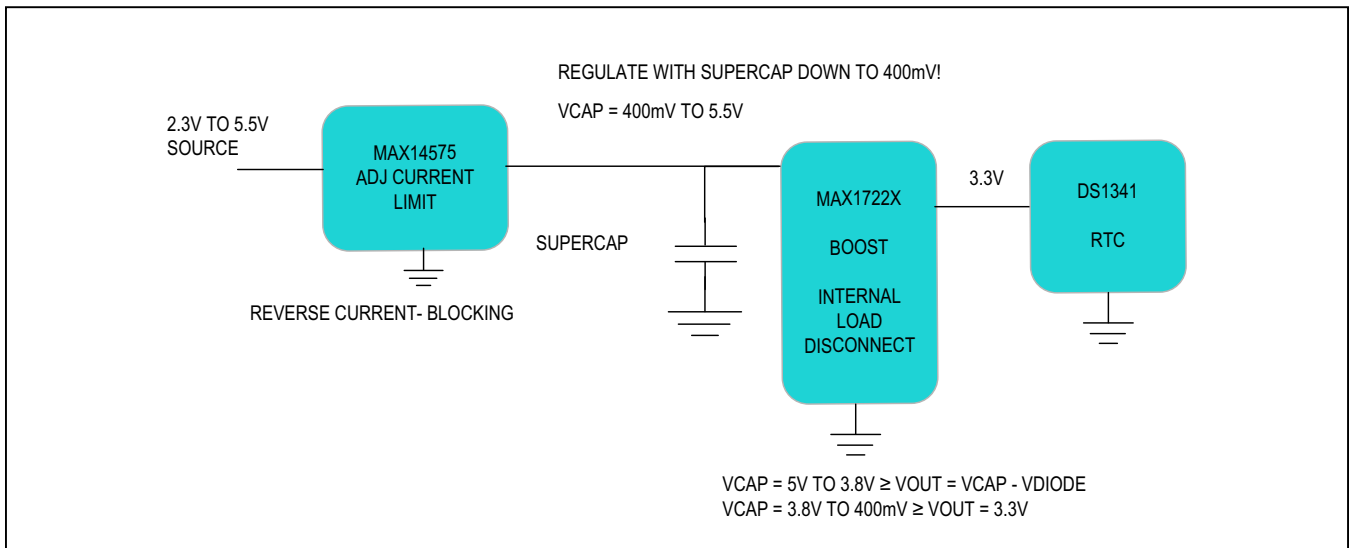

Figure 10. MAX1722x/MAX14575/DS1341 RTC Backup Solution.

**Supercap Backup Solution to Maintain Uniform Sound for Alarm Beeper Buzzers**

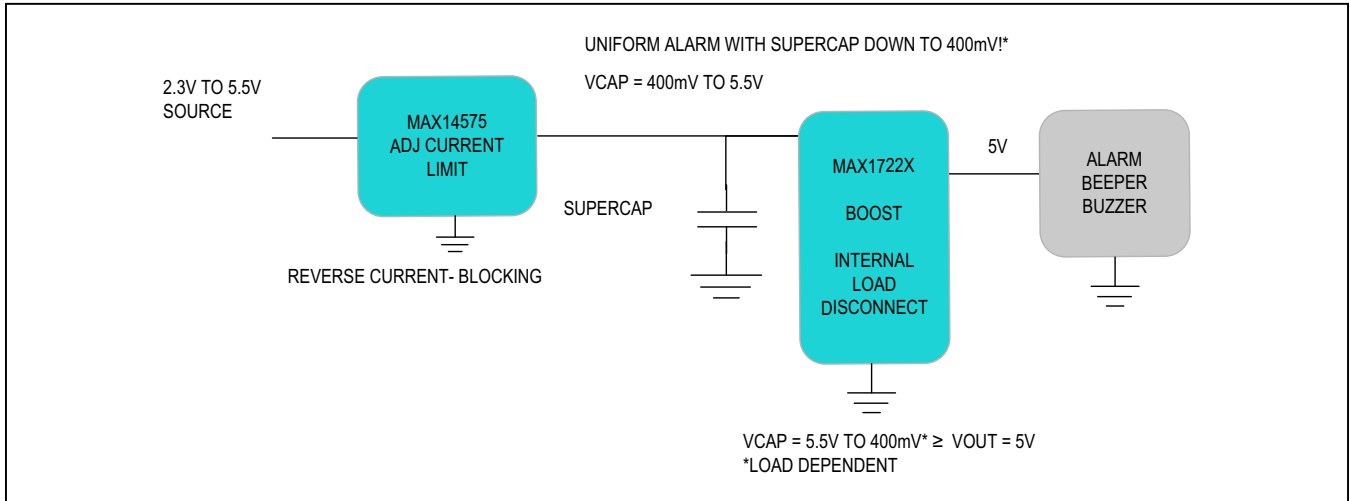

Figure 11. MAX1722x/MAX14575 Solution for Alarm Beeper Buzzers.

**Zero Reverse Current in True Shutdown for Multisource Applications**

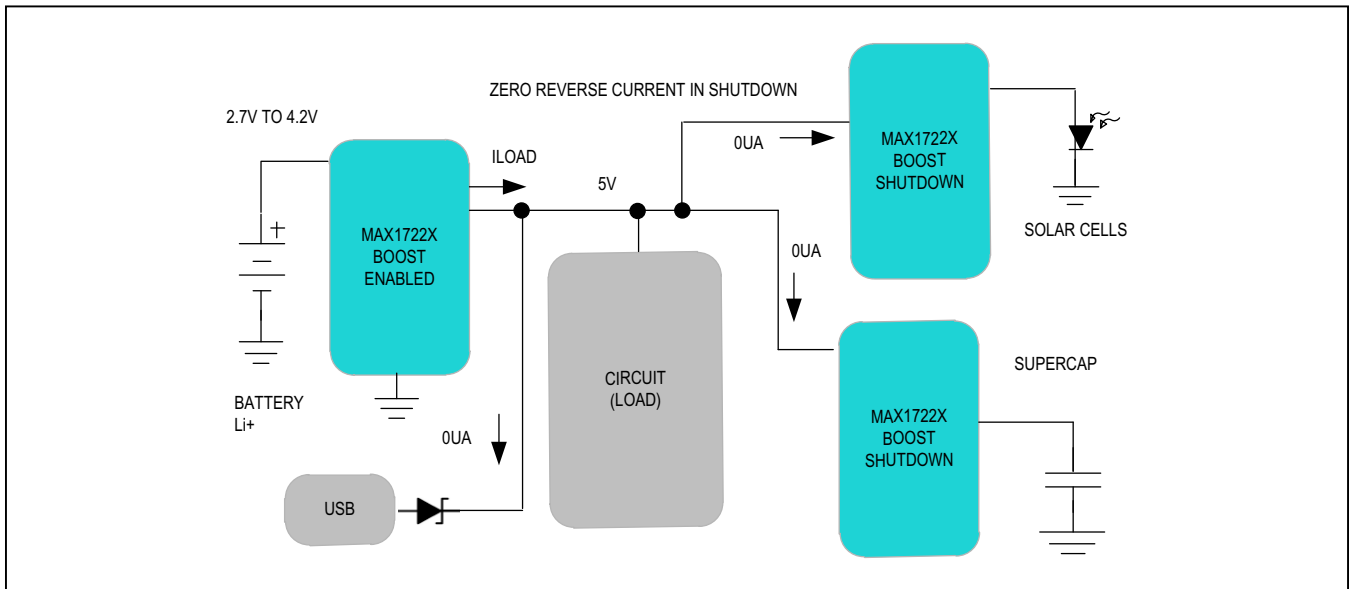

Figure 12. MAX1722x Has Zero Reverse Current in True Shutdown.

# MAX17220–MAX17225

# 400mV to 5.5V Input, nanoPower Synchronous Boost Converter with True Shutdown

## Typical Application Circuits

### Smallest Solution Size—0603 Inductor—MAX17222/MAX17223 500mA I<sub>LIM</sub> (Part 1)

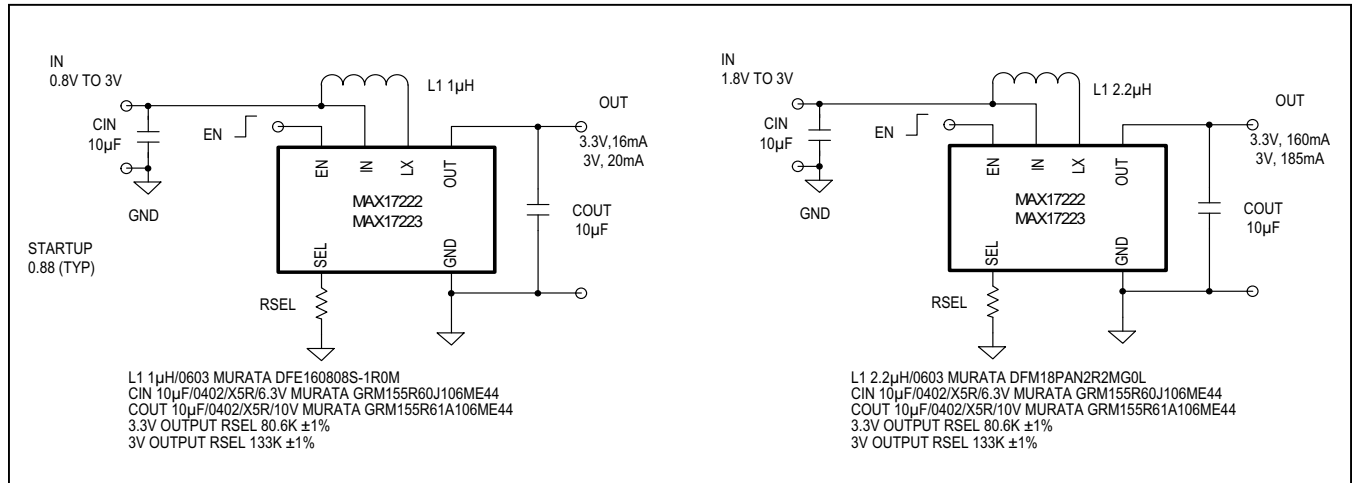

### Smallest Solution Size—0603 Inductor—MAX17222/MAX17223 500mA I<sub>LIM</sub> (Part 2)

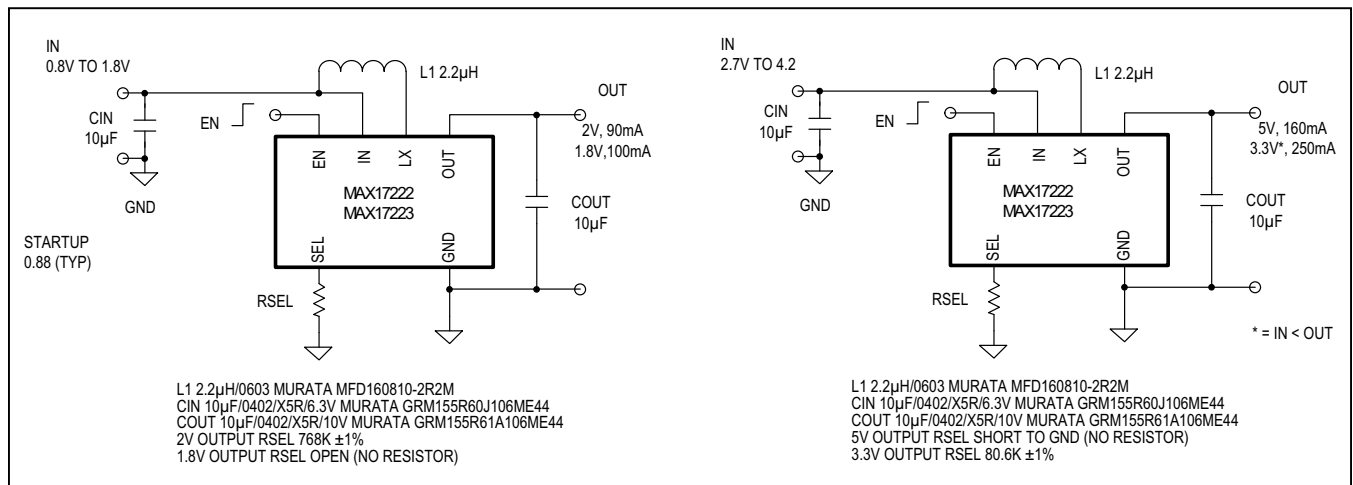

Typical Application Circuits (continued)

Highest Efficiency Solution—4mm x 4mm Inductor—MAX17222/MAX17223 500mA  $I_{LIM}$  (Part 1)

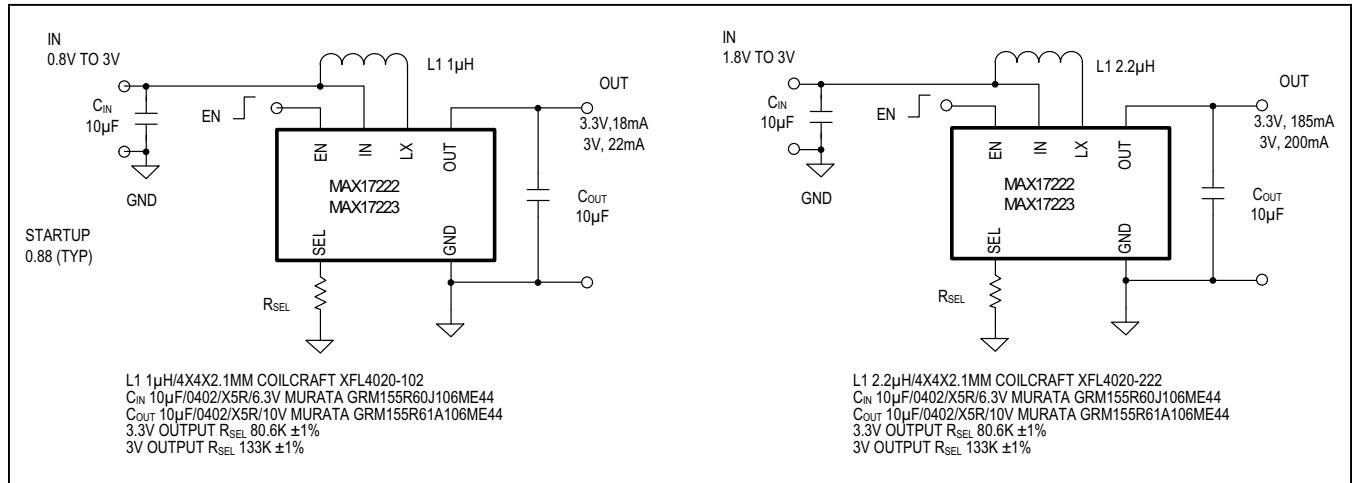

Highest Efficiency Solution—4 x 4mm Inductor—MAX17222/MAX17223 500mA  $I_{LIM}$  (Part 2)

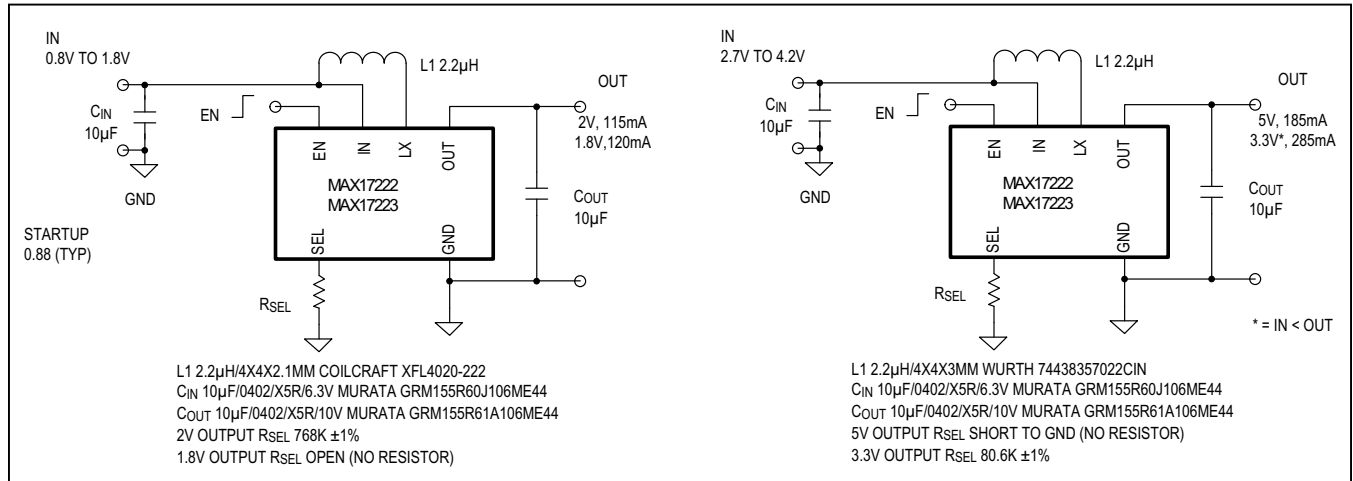

## Ordering Information

PART NUMBER	TEMPERATURE RANGE	PIN-PACKAGE	INPUT PEAK CURRENT I <sub>PEAK</sub>	TRUE SHUTDOWN	ENABLE TRANSIENT PROTECTION (ETP)
MAX17220ENT+	-40°C to +85°C	6 WLP	225mA	Yes	Yes
MAX17222ENT+	-40°C to +85°C	6 WLP	0.5A	Yes	Yes
MAX17223ENT+	-40°C to +85°C	6 WLP	0.5A	Yes	—
MAX17224ENT+	-40°C to +85°C	6 WLP	1A	Yes	Yes
MAX17225ENT+	-40°C to +85°C	6 WLP	1A	Yes	—
MAX17220ELT+	-40°C to +85°C	6 µDFN	225mA	Yes	Yes
MAX17222ELT+	-40°C to +85°C	6 µDFN	0.5A	Yes	Yes
MAX17223ELT+	-40°C to +85°C	6 µDFN	0.5A	Yes	—
MAX17224ELT+	-40°C to +85°C	6 µDFN	1A	Yes	Yes
MAX17225ELT+	-40°C to +85°C	6 µDFN	1A	Yes	—
MAX17220ALT+	-40°C to +125°C	6 µDFN	225mA	Yes	Yes
MAX17222ALT+	-40°C to +125°C	6 µDFN	500mA	Yes	Yes
MAX17223ALT+	-40°C to +125°C	6 µDFN	500mA	Yes	No
MAX17224ALT+	-40°C to +125°C	6 µDFN	1A	Yes	Yes
MAX17225ALT+	-40°C to +125°C	6 µDFN	1A	Yes	No

+Denotes a lead(Pb)-free/RoHS-compliant package.

T = Tape and reel.

## Revision History

REVISION NUMBER	REVISION DATE	DESCRIPTION	PAGES CHANGED
0	2/17	Initial release	—
1	4/17	Updated <i>Electrical Characteristics</i> and <i>Ordering Information</i> tables and added Operation with $V_{IN} > V_{OUT}$ section	3, 8, 13, 19, 21
2	5/17	Removed MAX17221 part number, general data sheet updates	1–23
3	7/17	Updated Shutdown Current into IN and Total Shutdown Current into IN LX conditions, Note 5, TOC 5, <i>True Shutdown Current</i> section, Figure 10, added TOC 18, removed future product references (MAX17220ENT+, MAX17224ENT+, MAX17220ELT+, MAX17223ELT+, and MAX17224ELT+)	3–5, 7, 10, 18, 22
4	2/19	Updated <i>Absolute Maximum Ratings</i> , <i>Electrical Characteristics</i> , <i>Detailed Description</i> , and <i>Ordering Information</i>	2–4, 13, 22

For pricing, delivery, and ordering information, please visit Maxim Integrated's online storefront at <https://www.maximintegrated.com/en/storefront/storefront.html>.

Maxim Integrated cannot assume responsibility for use of any circuitry other than circuitry entirely embodied in a Maxim Integrated product. No circuit patent licenses are implied. Maxim Integrated reserves the right to change the circuitry and specifications without notice at any time. The parametric values (min and max limits) shown in the *Electrical Characteristics* table are guaranteed. Other parametric values quoted in this data sheet are provided for guidance.

## Looking for pricing, stock, or lifecycle information?

Click below to explore more details on WIN SOURCE:

⊖ [View MAX17222EVKIT#](#) on WIN SOURCE

⊖ [Maxim Integrated](#) Information

## Optimize Your Supply Chain with WIN SOURCE Solutions

- ✓ Global Sourcing Solution
- ✓ Obsolete Management
- ✓ Cost Control Management
- ✓ Shortage Management
- ✓ Alternative Solution
- ✓ Excess Inventory Management