



**THE DATASHEET OF  
MAX13041ASD+**



# ±80V Fault-Protected High-Speed CAN Transceiver with Low-Power Management and Wake-On CAN

## General Description

The MAX13041 ±80V fault-protected, high-speed controller area network (CAN) transceiver is ideal for high-speed automotive network applications where high reliability and advanced power management are required. The device links a CAN protocol controller to the physical bus wires of the controller area network and allows communication at speeds up to 1Mbps.

The extended fault-protected voltage range of ±80V on CAN bus lines allows for use in +12V or +42V automotive, and higher voltage +24V and +36V mid-heavy truck applications. Advanced power management features make the MAX13041 ideal for automotive electronic control unit (ECU) modules that are permanently supplied by battery, regardless of the ignition switch position (clamp-30, Type-A modules). The device controls one or more external voltage regulators to provide a low-power sleep mode for an entire clamp-30 node. Wake-on CAN capability allows the MAX13041 to restore power to the node upon detection of CAN bus activity.

The MAX13041 is functionally compatible with the Philips TJA1041A and is a pin-to-pin replacement with improved performance. The MAX13041 is available in a 14-pin SO package, and operates over the -40°C to +125°C automotive temperature range.

## Applications

- +12V Automotive—Clamp 30 Modules
- +42V Automotive—Clamp 30 Modules
- +24V Mid-Heavy Truck—Clamp 30 Modules
- Military and Commercial Aircraft

## Features

- ◆ Functionally Compatible Pin-to-Pin Replacement for the Philips TJA1041A
- ◆ ±12kV HBM ESD Protection on CANH, CANL
- ◆ ±80V Fault Protection on CANH, CANL, SPLIT; Up to +76V Operation on VBAT
- ◆ Fully Compatible with the ISO11898 Standard
- ◆ Low VBAT Supply Current in Standby and Sleep Modes (18µA Typical)
- ◆ Voltage Level Translation for Interfacing with +2.8V to +5.5V CAN Protocol Controllers
- ◆ Recessive Bus Stabilization (SPLIT)
- ◆ Allows Implementation of Large Networks

## Ordering Information

PART	TEMP RANGE	PIN-PACKAGE
MAX13041ASD+	-40°C to +125°C	14 SO
MAX13041ASD/V+	-40°C to +125°C	14 SO

+ Denotes a lead(Pb)-free/RoHS-compliant package.  
N Denotes an automotive qualified part.

## Typical Operating Circuit

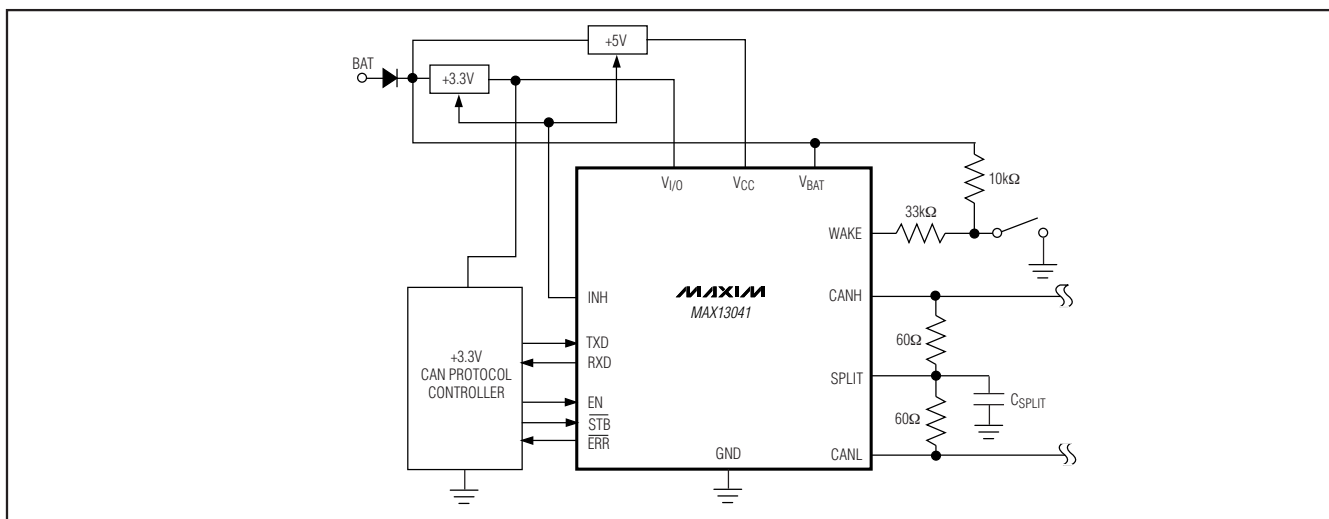

Pin Configuration appears at end of data sheet.

# ±80V Fault-Protected High-Speed CAN Transceiver with Low-Power Management and Wake-On CAN

## ABSOLUTE MAXIMUM RATINGS

(All voltages referenced to GND.)

V <sub>CC</sub> , V <sub>I/O</sub> .....	-0.3V to +6V
V <sub>BAT</sub> .....	-0.3V to +80V
TXD, RXD, STB, EN, ERR.....	-0.3V to +6V
INH, WAKE.....	-0.3V to (V <sub>BAT</sub> + 0.3V)
CANH, CANL, SPLIT.....	0V to ±80V continuous

Continuous Power Dissipation (T<sub>A</sub> = +70°C)

14-Pin SO (derate 8.3mW/°C above +70°C).....	667mW
Operating Temperature Range.....	-40°C to +125°C
Storage Temperature Range.....	-65°C to +150°C
Junction Temperature.....	+150°C
Lead Temperature (soldering, 10s).....	+300°C

Stresses beyond those listed under "Absolute Maximum Ratings" may cause permanent damage to the device. These are stress ratings only, and functional operation of the device at these or any other conditions beyond those indicated in the operational sections of the specifications is not implied. Exposure to absolute maximum rating conditions for extended periods may affect device reliability.

## ELECTRICAL CHARACTERISTICS

(V<sub>CC</sub> = +4.75V to +5.25V, V<sub>I/O</sub> = +2.8V to V<sub>CC</sub>, V<sub>BAT</sub> = +5V to +76V, T<sub>A</sub> = T<sub>MIN</sub> to T<sub>MAX</sub>, R<sub>L</sub> = 60Ω, unless otherwise noted. Typical values are at V<sub>CC</sub> = +5V, V<sub>I/O</sub> = +3.3V, V<sub>BAT</sub> = +12V and T<sub>A</sub> = +25°C.) (Notes 1, 2)

PARAMETER	SYMBOL	CONDITIONS	MIN	TYP	MAX	UNITS
V <sub>CC</sub> Input Voltage	V <sub>CC</sub>	Operating range	4.75		5.25	V
V <sub>I/O</sub> Input Voltage	V <sub>I/O</sub>	Operating range	2.80		5.25	V
V <sub>BAT</sub> Input Voltage	V <sub>BAT</sub>	Operating range	5		76	V
V <sub>CC</sub> Undervoltage Detection Level for Forced Sleep Mode	V <sub>CC(SLEEP)</sub>		2.75	3.3	4.50	V
V <sub>I/O</sub> Undervoltage Detection Level for Forced Sleep Mode	V <sub>I/O(SLEEP)</sub>		0.5	1.5	2.0	V
V <sub>BAT</sub> Voltage Level for Failsafe Fallback Mode	V <sub>BAT(STBY)</sub>	V <sub>CC</sub> = +5V (fail-safe)	2.75	3.3	4.50	V
V <sub>BAT</sub> Voltage Level for Setting PWON Flag	V <sub>BAT(PWON)</sub>	V <sub>CC</sub> = 0V	2.5	3.3	4.1	V
V <sub>CC</sub> Input Current	I <sub>CC</sub>	Normal mode, V <sub>TXD</sub> = 0V (dominant)		55	80	mA
		Normal or PWON/listen-only mode, V <sub>TXD</sub> = V <sub>I/O</sub> (recessive)		6	10	
		Standby or sleep mode		1.8	8	μA
V <sub>I/O</sub> Input Current	I <sub>I/O</sub>	Normal mode, V <sub>TXD</sub> = 0V (dominant)		230	700	μA
		Normal or PWON/listen-only mode, V <sub>TXD</sub> = V <sub>I/O</sub> (recessive)		1	5	
		Standby or sleep mode, V <sub>TXD</sub> = V <sub>I/O</sub>		0.7	3	

# ±80V Fault-Protected High-Speed CAN Transceiver with Low-Power Management and Wake-On CAN

MAX13041

## ELECTRICAL CHARACTERISTICS (continued)

( $V_{CC} = +4.75V$  to  $+5.25V$ ,  $V_{I/O} = +2.8V$  to  $V_{CC}$ ,  $V_{BAT} = +5V$  to  $+76V$ ,  $T_A = T_{MIN}$  to  $T_{MAX}$ ,  $R_L = 60\Omega$ , unless otherwise noted. Typical values are at  $V_{CC} = +5V$ ,  $V_{I/O} = +3.3V$ ,  $V_{BAT} = +12V$  and  $T_A = +25^\circ C$ .) (Notes 1, 2)

PARAMETER	SYMBOL	CONDITIONS	MIN	TYP	MAX	UNITS
VBAT Input Current	IBAT	Normal or PWON/listen-only mode, $V_{BAT} = +5V$ to $+76V$		20	40	$\mu A$
		Standby mode, $V_{INH} = V_{WAKE} = V_{BAT} = +12V$		18	28	
		Sleep mode, $V_{INH} = V_{CC} = V_{I/O} = 0V$ , $V_{WAKE} = V_{BAT} = +12V$		18	28	
<b>TRANSMITTER DATA INPUT (TXD)</b>						
High-Level Input Voltage	$V_{IH}$		$0.7 \times V_{I/O}$		$V_{I/O} + 0.3$	V
Low-Level Input Voltage	$V_{IL}$				$0.3 V_{I/O}$	V
High-Level Input Current	$I_{IH}$	$V_{TXD} = V_{I/O}$	-5	0	+5	$\mu A$
Low-Level Input Current	$I_{IL}$	$V_{TXD} = 0.3 V_{I/O}$	-70	-250	-500	$\mu A$
Input Capacitance	$C_I$			5		pF
<b>RECEIVER DATA OUTPUT (RXD)</b>						
High-Level Output Current	$I_{OH}$	$V_{RXD} = V_{I/O} - 0.4V$ , $V_{I/O} = V_{CC}$	-1	-3	-6	mA
Low-Level Output Current	$I_{OL}$	$V_{RXD} = +0.4V$ , $V_{TXD} = V_{I/O}$ , bus dominant	2	5	12	mA
<b>STANDBY AND ENABLE CONTROL INPUTS (STB AND EN)</b>						
High-Level Input Voltage	$V_{IH}$		$0.7 \times V_{I/O}$		$V_{I/O} + 0.3$	V
Low-Level Input Voltage	$V_{IL}$				$0.3 V_{I/O}$	V
High-Level Input Current	$I_{IH}$	$V_{STB} = V_{EN} = 0.7 V_{I/O}$	1	4	10	$\mu A$
Low-Level Input Current	$I_{IL}$	$V_{STB} = V_{EN} = 0V$	-1	0	+1	$\mu A$
<b>ERROR AND POWER-ON INDICATION OUTPUT (ERR)</b>						
High-Level Output Current	$I_{OH}$	$V_{ERR} = V_{I/O} - 0.4V$ , $V_{I/O} = V_{CC}$	-4	-20	-50	$\mu A$
Low-Level Output Current	$I_{OL}$	$V_{ERR} = +0.4V$	0.10	0.2	0.35	mA
<b>LOCAL WAKE-UP INPUT (WAKE)</b>						
High-Level Input Current	$I_{IH}$	$V_{WAKE} = V_{BAT} - 1.9V$	-1	-5	-10	$\mu A$
Low-Level Input Current	$I_{IL}$	$V_{WAKE} = V_{BAT} - 3.2V$	1	5	10	$\mu A$
Threshold Voltage	$V_{TH}$	$V_{STB} = 0V$	$V_{BAT} - 3.2$	$V_{BAT} - 2.5$	$V_{BAT} - 1.9$	V
<b>INHIBIT OUTPUT (INH)</b>						
High-Level Voltage Drop	$\Delta V_H$	$I_{INH} = -0.18mA$	0.05	0.2	0.80	V
Leakage Current	$I_{L I}$	Sleep mode		0	5	$\mu A$

# ±80V Fault-Protected High-Speed CAN Transceiver with Low-Power Management and Wake-On CAN

## ELECTRICAL CHARACTERISTICS (continued)

( $V_{CC} = +4.75V$  to  $+5.25V$ ,  $V_{I/O} = +2.8V$  to  $V_{CC}$ ,  $V_{BAT} = +5V$  to  $+76V$ ,  $T_A = T_{MIN}$  to  $T_{MAX}$ ,  $R_L = 60\Omega$ , unless otherwise noted. Typical values are at  $V_{CC} = +5V$ ,  $V_{I/O} = +3.3V$ ,  $V_{BAT} = +12V$  and  $T_A = +25^\circ C$ .) (Notes 1, 2)

PARAMETER	SYMBOL	CONDITIONS	MIN	TYP	MAX	UNITS	
<b>BUS LINES (CANH AND CANL)</b>							
Dominant Output Voltage	$V_{O(DOM)}$	$V_{TXD} = 0V$	CANH	3.00	3.7	4.25	V
			CANL	0.50	1.3	1.75	
Differential Bus Output Voltage ( $V_{CANH} - V_{CANL}$ )	$V_{O(DIF)(BUS)}$	$V_{TXD} = 0V$ , $45\Omega < R_L < 65\Omega$			3.0	V	
		$V_{TXD} = V_{I/O}$ , no load			-50	+50	mV
Recessive Output Voltage	$V_{O(RECES)}$	Normal or PWON/listen-only mode; $V_{TXD} = V_{I/O}$ , no load		2	2.4	3	V
		Standby or sleep mode, no load		-0.1	0	+0.1	V
Short-Circuit Current	$I_{O(SC)}$	$V_{TXD} = 0V$	CANH, $V_{CANH} = -5V$	-45	66	-95	mA
			CANL, $V_{CANL} = +40V$ (Note 3)	45	70	100	
Detectable Short-Circuit Resistance Among Bus Lines $V_{BAT}$ , $V_{CC}$ , and GND	$R_{SC(BUS)}$	Normal mode		0	50	$\Omega$	
Recessive Output Current	$I_{O(RECES)}$	$-40V < V_{CANH}$ , $V_{CANL} < +40V$		-3.1	+3.1	mA	
Differential Receiver Threshold Voltage	$V_{DIF(TH)}$	$-12V < V_{CANH}$ , $V_{CANL} < +12V$ , normal or PWON/listen-only mode		0.5	0.7	0.9	V
		$-12V < V_{CANH}$ , $V_{CANL} < +12V$ , standby or sleep mode		0.50	0.76	1.15	V
Differential Receiver Hysteresis Voltage	$V_{HYS(DIF)}$	Normal or PWON/listen-only mode $-12V < V_{CANH}$ ; $V_{CANL} < +12V$			60	mV	
Input Leakage Current	$I_{LI}$	$V_{CC} = 0V$ ; $V_{CANH} = V_{CANL} = +5V$			200	280	$\mu A$
Common-Mode Input Resistance	$R_{I(CM)}$	Standby or normal mode (Note 4)		15	25	35	k $\Omega$
Common-Mode Input Resistance Matching	$R_{I(CM)(M)}$	$V_{CANH} = V_{CANL}$		-3	0	+3	%
Differential Input Resistance	$R_{I(DIF)}$	Standby or normal mode		25	50	75	k $\Omega$
Common-Mode Input Capacitance	$C_{I(CM)}$	$V_{TXD} = V_{CC}$			20		pF
Differential Input Capacitance	$C_{I(DIF)}$	$V_{TXD} = V_{CC}$			10		pF
ESD Protection		Human Body Model (HBM)			$\pm 12$		kV
<b>COMMON-MODE STABILIZATION (SPLIT)</b>							
Output Voltage	$V_O$	Normal or PWON/listen-only mode $-500\mu A < I_{SPLIT} < +500\mu A$		0.3 $V_{CC}$	0.5 $V_{CC}$	0.7 $V_{CC}$	V
Leakage Current	$ I_{LI} $	Standby or sleep mode $-40V < V_{SPLIT} < +40V$			0	5	$\mu A$
<b>THERMAL PROTECTION</b>							
Thermal Shutdown Threshold	$T_{J(SD)}$				165		$^\circ C$
Thermal Shutdown Hysteresis	$T_{J(SD)HYST}$				10		$^\circ C$

# ±80V Fault-Protected High-Speed CAN Transceiver with Low-Power Management and Wake-On CAN

MAX13041

## TIMING CHARACTERISTICS

( $V_{CC} = +4.75V$  to  $+5.25V$ ,  $V_{I/O} = +2.8V$  to  $V_{CC}$ ,  $V_{BAT} = +5V$  to  $+76V$ ,  $T_A = T_{MIN}$  to  $T_{MAX}$ ,  $R_L = 60\Omega$ , unless otherwise noted. Typical values are at  $V_{CC} = +5V$ ,  $V_{I/O} = +3.3V$ ,  $V_{BAT} = +12V$  and  $T_A = +25^\circ C$ .) (Note 2)

PARAMETER	SYMBOL	CONDITIONS	MIN	TYP	MAX	UNITS
Delay TXD to Bus Active	$t_D(TXD-BUSON)$	Normal mode (Figures 1 and 2)		46	100	ns
Delay TXD to Bus Inactive	$t_D(TXD-BUSOFF)$	Normal mode (Figures 1 and 2)		60	100	ns
Delay Bus Active to RXD	$t_D(BUSON-RXD)$	Normal or PWON/listen-only mode (Figures 1 and 2)		59	115	ns
Delay Bus Inactive to RXD	$t_D(BUSOFF-RXD)$	Normal or PWON/listen-only mode (Figures 1 and 2)		60	160	ns
Undervoltage Detection Time on $V_{CC}$ and $V_{I/O}$	$t_{UV}(V_{CC})$ , $t_{UV}(V_{I/O})$	$V_{BAT} = +12V$	5.0	8.4	12.5	ms
TXD Dominant Timeout	$t_{DOM}(TXD)$	$V_{TXD} = 0V$	300	610	1000	$\mu s$
Bus Dominant Timeout	$t_{DOM}(BUS)$	$V_O(DIF)_{BUS} > 0.9V$	300	620	1000	$\mu s$
Minimum Hold Time of Go-to-Sleep Command	$t_H(MIN)$	$V_{BAT} = +12V$	17	34	56	$\mu s$
Dominant Time for Wake-Up Through Bus	$t_{BUSDOM}$	Standby or sleep mode, $V_{BAT} = +12V$ , $CANL = 0V$ , $CANH$ pulse $0V$ to $+2V$ (Note 5)	0.9	2	5.0	$\mu s$
Minimum Wake-Up Time After Receiving a Falling or Rising Edge on WAKE	$t_{WAKE}$	Standby or sleep mode; $V_{BAT} = +12V$	5	25	50	$\mu s$

**Note 1:** Positive current flows into the device.

**Note 2:** Limits over the operating temperature range are tested at worst-case supply voltage and compliant over the complete voltage range.

**Note 3:** Current measured at  $+20V$  and guaranteed by design up to  $+40V$ .

**Note 4:** Common-mode voltage range  $\pm 40V$ .

**Note 5:** A remote wake-on CAN request is generated upon the detection of two dominant bus cycles, each followed by a recessive bus cycle.

# ±80V Fault-Protected High-Speed CAN Transceiver with Low-Power Management and Wake-On CAN

## Typical Operating Characteristics

( $V_{CC} = +5V$ ,  $V_{I/O} = +3.3V$ ,  $V_{BAT} = +12V$ ,  $R_L = 60\Omega$ ,  $C_{SPLIT} = 4700pF$ ,  $T_A = +25^\circ C$ , unless otherwise noted.)

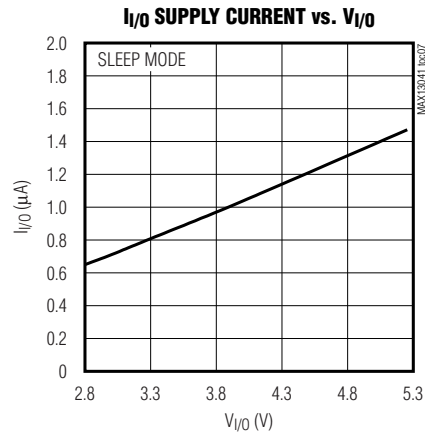
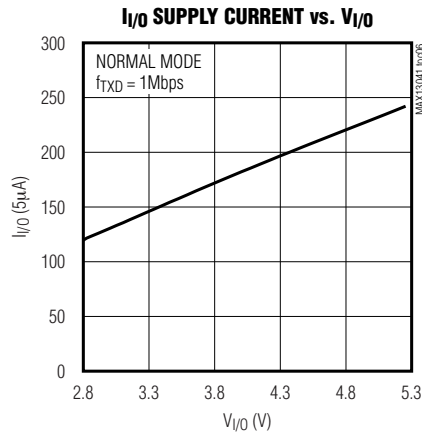
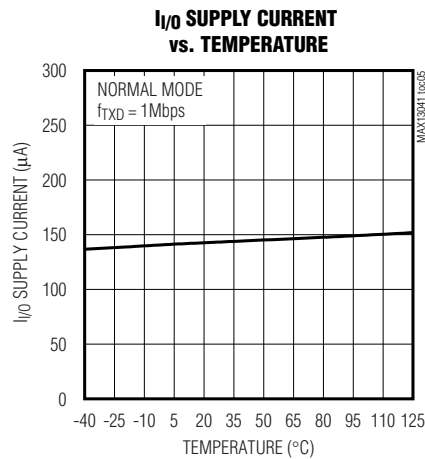
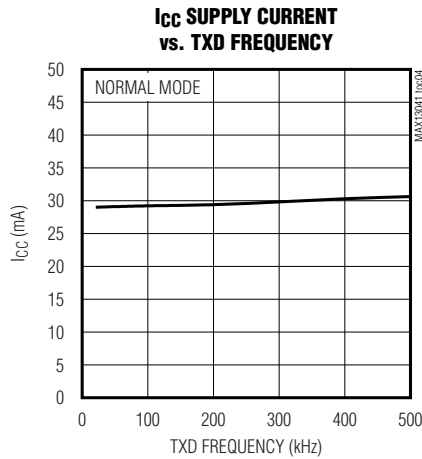
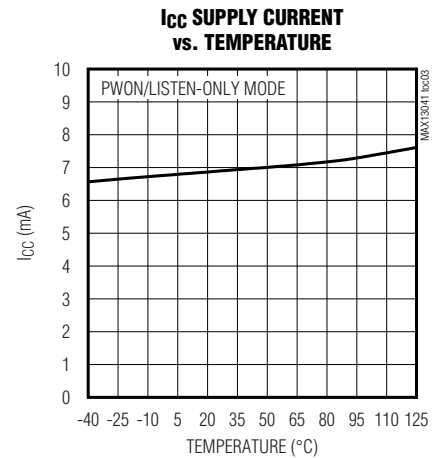
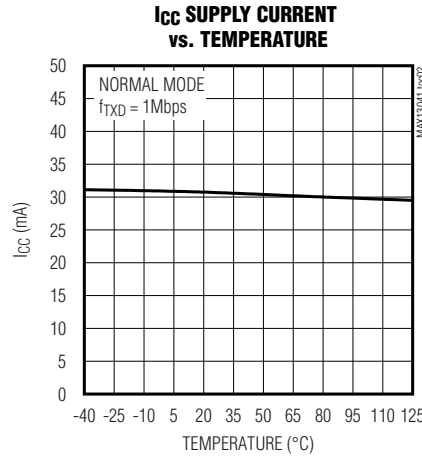
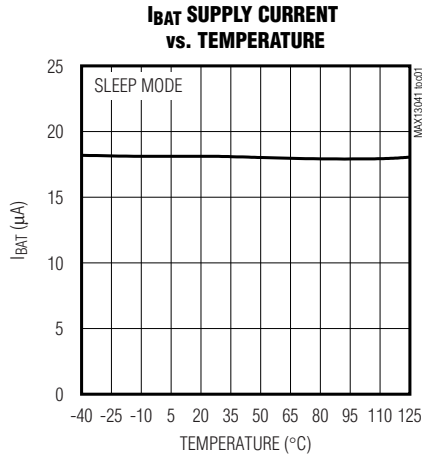

# ±80V Fault-Protected High-Speed CAN Transceiver with Low-Power Management and Wake-On CAN

## Typical Operating Characteristics (continued)

( $V_{CC} = +5V$ ,  $V_{I/O} = +3.3V$ ,  $V_{BAT} = +12V$ ,  $R_L = 60\Omega$ ,  $C_{SPLIT} = 4700pF$ ,  $T_A = +25^\circ C$ , unless otherwise noted.)

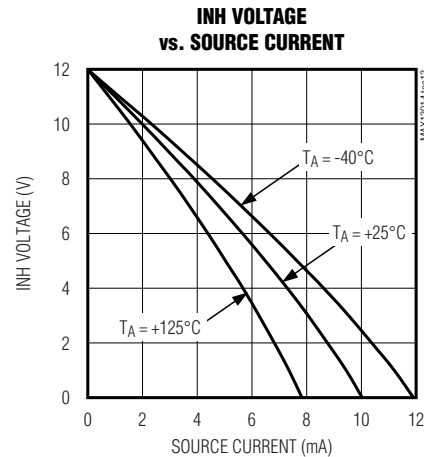
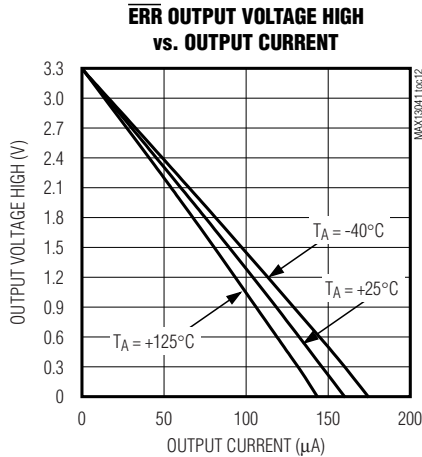
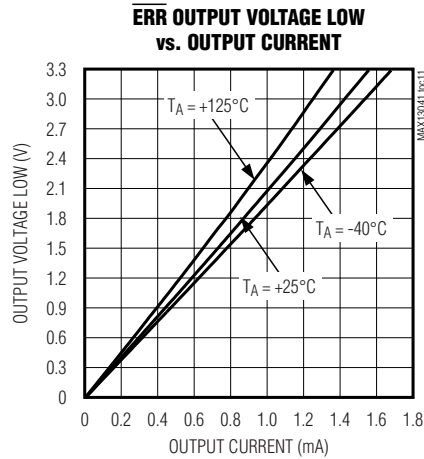
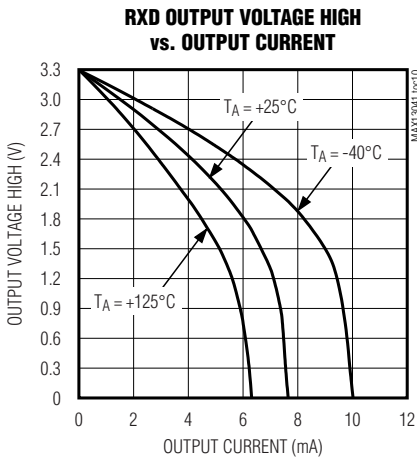
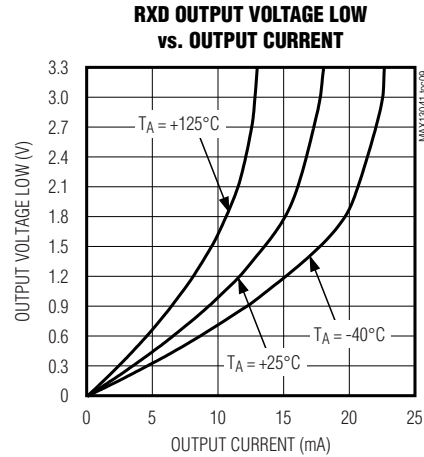
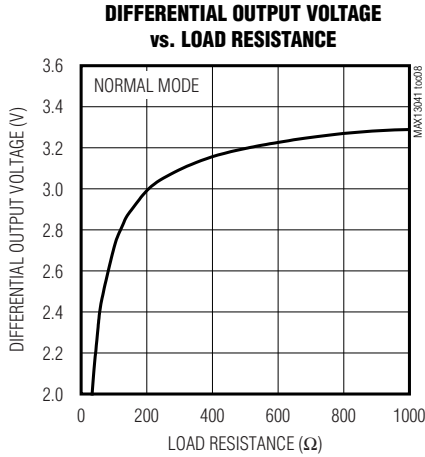

# ±80V Fault-Protected High-Speed CAN Transceiver with Low-Power Management and Wake-On CAN

## Typical Operating Characteristics (continued)

( $V_{CC} = +5V$ ,  $V_{I/O} = +3.3V$ ,  $V_{BAT} = +12V$ ,  $R_L = 60\Omega$ ,  $C_{SPLIT} = 4700pF$ ,  $T_A = +25^\circ C$ , unless otherwise noted.)

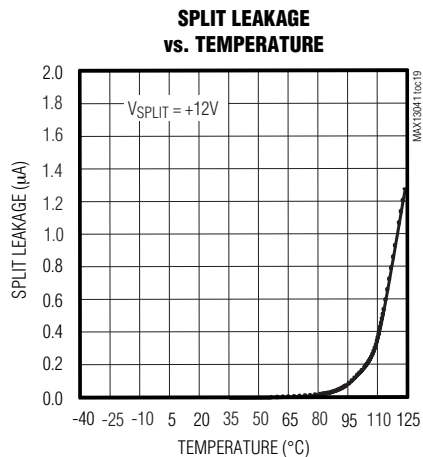
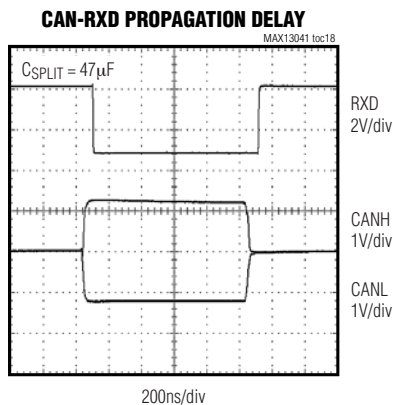
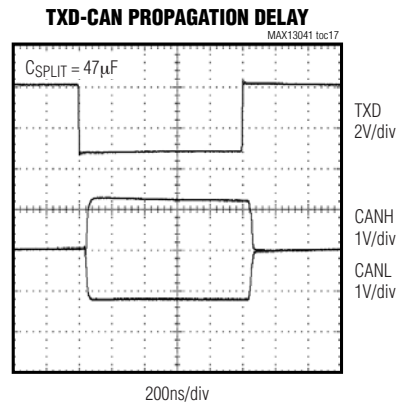
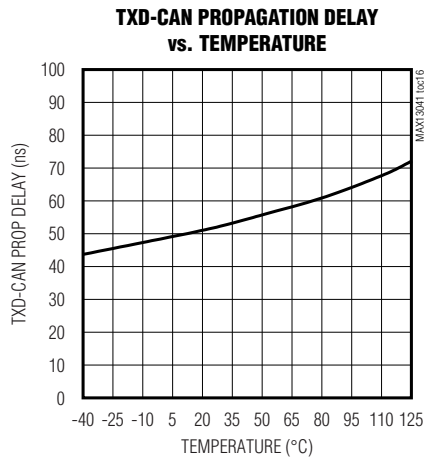
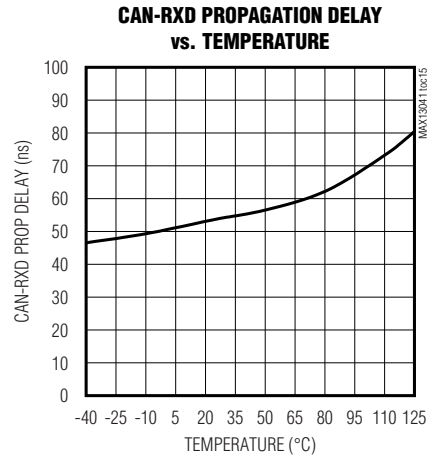
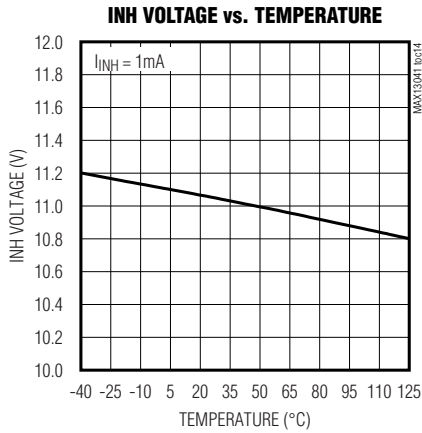

# ±80V Fault-Protected High-Speed CAN Transceiver with Low-Power Management and Wake-On CAN

## Pin Description

PIN	NAME	FUNCTION
1	TXD	Data Transmit Input, CMOS Compatible. TXD is internally pulled up to $V_{I/O}$ .
2	GND	Ground
3	$V_{CC}$	Supply Voltage +4.75V to +5.25V. Bypass $V_{CC}$ to ground with a 0.1 $\mu$ F ceramic capacitor as close as possible to the device.
4	RXD	Data Receive Output, CMOS Compatible
5	$V_{I/O}$	Supply Voltage for I/O Level Translation, $+2.8V < V_{I/O} < V_{CC}$ (see the <i>Level Shifting</i> section). Bypass $V_{I/O}$ to ground with a 0.1 $\mu$ F ceramic capacitor as close as possible to the device.
6	EN	Enable Input. Control the operating mode by driving EN logic-high or logic-low (see Table 1 and Figure 4.)
7	INH	Inhibit Output. INH controls one or more external voltage regulators.
8	$\overline{ERR}$	Error Output, Active Low. $\overline{ERR}$ indicates errors and displays status of internal flags.
9	WAKE	Local Wake-Up Input. Present a voltage transition on WAKE to generate a local wake-up event.
10	$V_{BAT}$	Battery Voltage Input. Bypass $V_{BAT}$ to ground with a 0.1 $\mu$ F ceramic capacitor as close as possible to the device.
11	SPLIT	Split Termination Voltage Output. Connect SPLIT to the center node of two 60 $\Omega$ termination resistors to provide common-mode voltage stabilization (see Figure 3). SPLIT outputs a voltage of $V_{CC}/2$ .
12	CANL	Low-Level CAN Differential Bus Line
13	CANH	High-Level CAN Differential Bus Line
14	$\overline{STB}$	Standby Input, Active Low. Drive $\overline{STB}$ logic-high or logic-low to control the operating mode (see Table 1 and Figure 4.)

MAX13041

# ±80V Fault-Protected High-Speed CAN Transceiver with Low-Power Management and Wake-On CAN

## Timing Diagrams

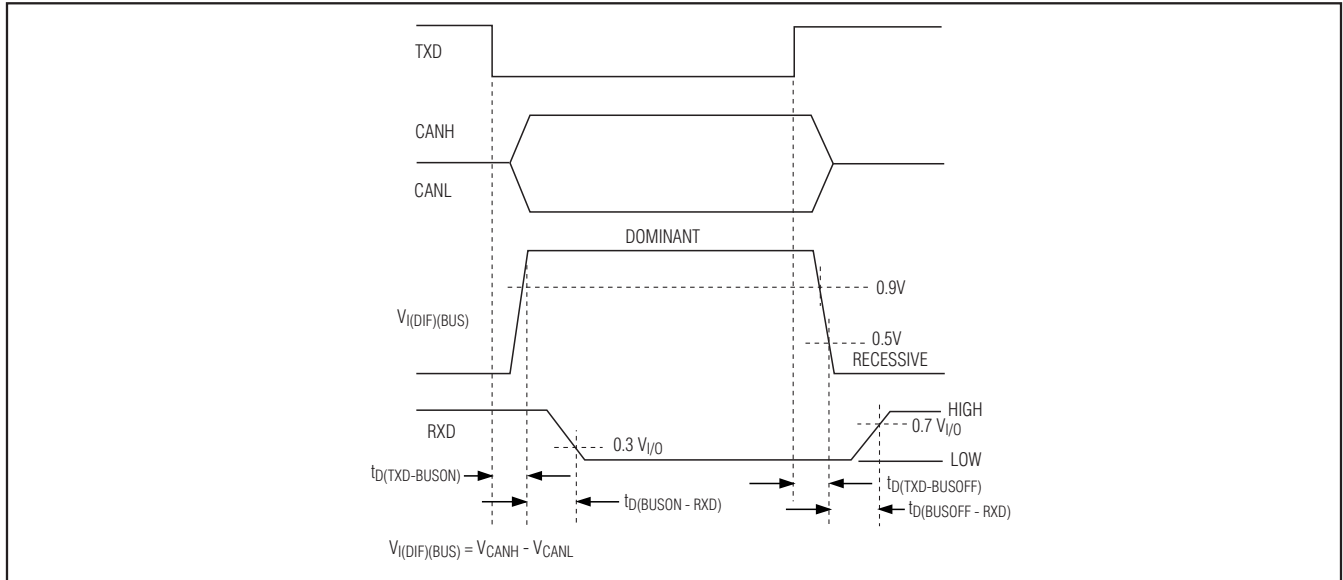

Figure 1. Timing Diagram

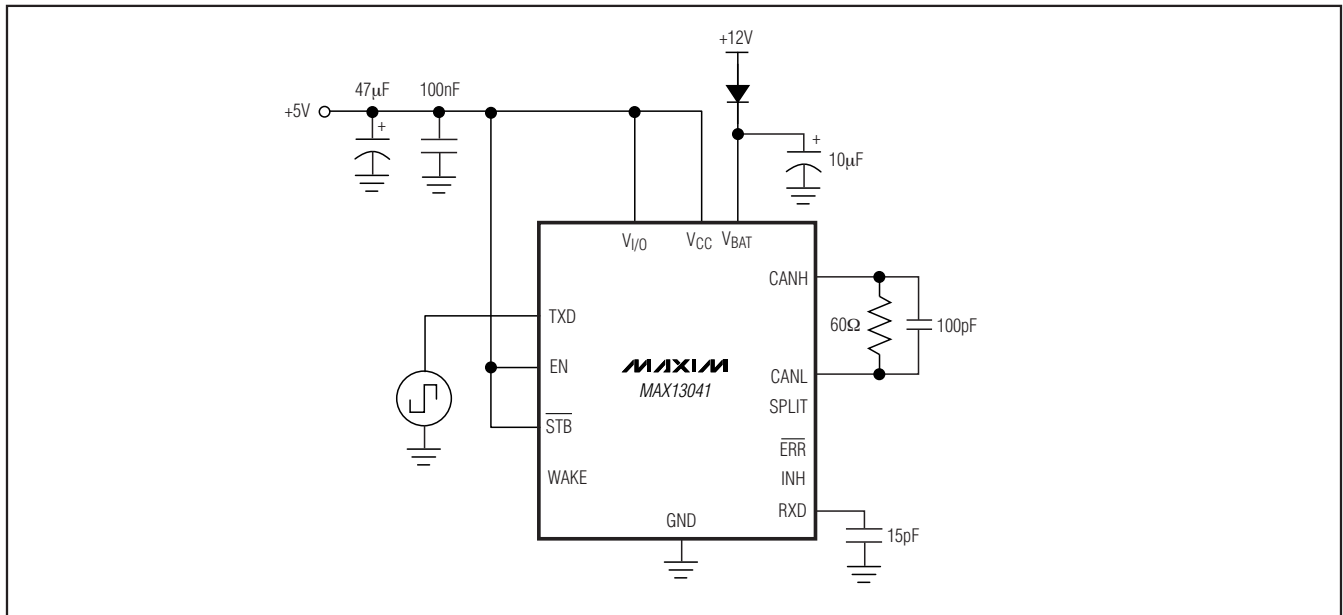

Figure 2. Test Circuit for Timing Characteristics

# ±80V Fault-Protected High-Speed CAN Transceiver with Low-Power Management and Wake-On CAN

## Detailed Description

The MAX13041 ±80V fault-protected, high-speed CAN transceiver is intended for high-speed industrial and automotive network applications where high reliability and advanced power management are required. The device links a CAN protocol controller to the physical bus wires of the controller area network (CAN) and allows communication at speeds up to 1Mbps. Built-in level shifting allows for direct connection to protocol controllers operating from lower voltages. The extended fault-protected voltage range of ±80V on CAN bus lines allows for use in +12V or +42V automotive, and higher voltage +24V and +36V heavy-duty truck applications.

Advanced power management features make the MAX13041 ideal for automotive electronic control unit (ECU) modules that are permanently supplied by battery, regardless of the ignition switch position (clamp-30, type-A modules). The device controls one or more external voltage regulators to provide a low-power sleep mode for an entire clamp-30 node. Wake-on CAN capability allows the MAX13041 to restore power to the node upon detection of CAN bus activity. The MAX13041 is functionally compatible with the Philips TJA1041A and is a pin-to-pin replacement with improved performance.

### CAN Interface

The ISO11898 specification describes the physical layer of a controller area network (CAN). A CAN implementation is comprised of multiple transceiver modules linked by a pair of bus wires. Communication between modules occurs through transmission and reception of differential logic states on the bus lines. Two complimentary logic states are defined by ISO11898. A dominant state results when the differential voltage on the CAN bus lines is greater than 0.9V. A recessive bus state results when the differential voltage is less than 0.5V (Figure 1). The CAN bus exhibits a wired-AND characteristic, meaning the bus is only recessive when all connected transmitters are recessive. Any transmitter asserting a dominant logic state forces the entire CAN bus dominant.

The MAX13041 accepts logic-level data from the CAN protocol controller on TXD. Drive TXD low to assert a dominant state on the CAN bus. Drive TXD high to release the CAN bus to a recessive state. TXD is internally pulled up to  $V_{I/O}$ . The state of the CAN bus is presented to the protocol controller as a logic level on RXD. The MAX13041 receiver remains active during transmission to allow for the bit-wise arbitration scheme specified by the CAN protocol.

### Level Shifting

The MAX13041 provides level shifting on TXD, RXD, EN,  $\overline{STB}$ , WAKE and  $\overline{ERR}$  for compatibility with lower-voltage protocol controllers. Set the interface logic levels for TXD, RXD, EN,  $\overline{STB}$ , WAKE, and  $\overline{ERR}$  by connecting  $V_{I/O}$  to the supply voltage of a CAN protocol controller, or another voltage from +2.8V to +5.25V.

### Split-Termination and Common-Mode Voltage Stabilization

The CAN bus specification requires a total bus load resistance of 60Ω. Each end of the bus should be terminated with 120Ω, the characteristic impedance of the bus line. Electromagnetic emission (EME) is reduced by a split-termination method, whereby each end of the bus line is terminated by 120Ω split into two 60Ω resistors in series (see Figure 3). A bypass capacitor shunts noise to ground from the node connecting the 60Ω resistors.

When the CAN bus is recessive, the common-mode voltage is pulled low by the leakage current from inactive modules. When the CAN bus subsequently goes dominant, the proper common-mode voltage is restored by the transmitting device. A common-mode voltage step results, generating excessive EME. To mitigate this problem, the common-mode voltage of the bus is forced to  $V_{CC}/2$  by biasing the split-termination node (see Figure 3). During normal and PWON/listen-only modes, a stabilized DC voltage of  $V_{CC}/2$  is present on SPLIT. Connect SPLIT to the node connecting the two 60Ω termination resistors to stabilize the common-mode voltage of the bus and prevent EME from common-mode voltage steps.

### Power-Management Operating Modes

The MAX13041 provides advanced power management for a clamp-30 node by controlling one or more external voltage regulators. Five operating modes provide different functionality to minimize power consumption.

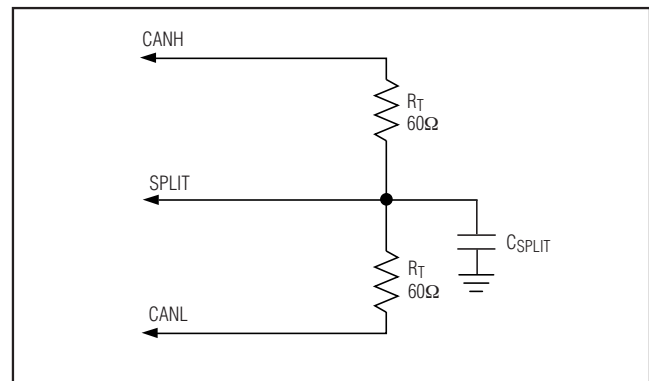

Figure 3. Biased Split Termination

# ±80V Fault-Protected High-Speed CAN Transceiver with Low-Power Management and Wake-On CAN

In the lowest-power mode, the MAX13041 disables external voltage regulators to provide a sleep mode for the entire node. The MAX13041 restores power to the node upon a logic transition on WAKE or detection of CAN bus activity.

The operating mode is determined by an internal state machine controlled by EN and  $\overline{STB}$ , as well as several internal flags (see Table 1 and Figure 4).

### Normal Mode

The MAX13041 provides full bidirectional CAN communication in normal mode. Drive TXD to transmit data on the differential CAN bus lines CANH and CANL. The CAN bus state is presented on RXD, a level-shifted logic output. SPLIT is biased to  $V_{CC}/2$  to allow CAN bus common-mode stabilization. INH is logic-high, enabling one or more external voltage regulators (see Table 1).

### PWON/Listen-Only Mode

In PWON/listen-only mode, the CAN transmitter is disabled. The CAN receiver remains active and the CAN bus state is presented on RXD, a level-shifted logic output. As in normal mode, SPLIT is biased to  $V_{CC}/2$  to allow CAN bus common-mode stabilization. INH is logic-high, enabling one or more external voltage regulators (see Table 1).

### Standby Mode

Standby mode is the first low-power operating mode. The CAN transmitter and receiver are disabled, and a low-power receiver is enabled to monitor the CAN bus for activity. To reduce power consumption, common-mode stabilization is disabled. SPLIT becomes high impedance, and CANH and CANL are biased to ground by the termination resistors. INH remains logic-high, enabling one or more external voltage regulators (see Table 1).

### Go-to-Sleep Command Mode

Go-to-sleep command mode is part of the controlled sequence for entering sleep mode. The MAX13041 remains in go-to-sleep command mode for a hold time of 56 $\mu$ s (max), and subsequently enters sleep mode if no wake events are detected. During the hold time, if the state of EN or  $\overline{STB}$  changes, or if the UV<sub>BAT</sub>, PWON, or wake-up flags are set, the go-to-sleep sequence is aborted. During go-to-sleep command mode, functionality is the same as in standby mode.

### Sleep Mode

Sleep mode is the lowest-power operating mode. The CAN transmitter and receiver are disabled, and a low-power receiver is enabled to monitor the CAN bus for

**Table 1. Operating Modes**

CONTROL PINS		INTERNAL FLAGS			OPERATING MODE	INH
$\overline{STB}$	EN	UV <sub>NOM</sub>	UV <sub>BAT</sub>	PWON, WAKE-UP		
X	X	SET	X	X	SLEEP (Notes 6, 7)	FLOATING
		CLEAR	SET	EITHER FLAG SET	STANDBY	H
L	L	CLEAR	CLEAR	BOTH FLAGS CLEAR	STANDBY FROM ANY OTHER MODE	H
				EITHER FLAG SET	STANDBY	H
L	L	CLEAR	CLEAR	BOTH FLAGS CLEAR	NO CHANGE FROM SLEEP MODE	FLOATING
				EITHER FLAG SET	STANDBY	H
L	H	CLEAR	CLEAR	BOTH FLAGS CLEAR	GO-TO-SLEEP COMMAND MODE FROM ANY OTHER MODE (Note 7)	H
				EITHER FLAG SET	NO CHANGE FROM SLEEP MODE	FLOATING
H	L	CLEAR	CLEAR	X	PWON/LISTEN-ONLY	H
H	H	CLEAR	CLEAR	X	NORMAL (Note 9)	H

**Note 6:** Setting the PWON or wake-up flags clears UV<sub>NOM</sub> flag.

**Note 7:** The MAX13041 enters sleep mode from any other mode when UV<sub>NOM</sub> is set. INH becomes high impedance.

**Note 8:** When go-to-sleep command mode is selected for longer than t<sub>H(MIN)</sub>, the MAX13041 enters sleep mode. INH becomes high impedance.

**Note 9:** PWON and wake-up flags are cleared upon entering normal mode.



# ±80V Fault-Protected High-Speed CAN Transceiver with Low-Power Management and Wake-On CAN

Table 2. Flag Signaling on  $\overline{\text{ERR}}$

INTERNAL FLAG	FLAG AVAILABLE ON $\overline{\text{ERR}}$	CONDITIONS TO CLEAR FLAG
UVNOM	No	Set PWON or wake-up flags
UVBAT	No	Recovery of V <sub>BAT</sub>
PWON	In PWON/listen-only mode (changing from standby, go-to-sleep command, or sleep modes)	Entering normal mode
Wake-Up	In standby, go-to-sleep command, and sleep modes (provided V <sub>I/O</sub> and V <sub>CC</sub> are present)	Entering normal mode or setting PWON or UVNOM flag
Wake-Up Source	In normal mode (before the fourth dominant to recessive edge on TXD, Note 10)	Leaving normal mode or setting PWON flag
Bus Failure	In normal mode (after the fourth dominant to recessive edge on TXD, Note 10)	Re-entering normal mode
Local Failure	In PWON/listen-only mode (coming from normal mode)	Entering normal mode or whenever RXD is dominant while TXD is recessive (and all local failures are resolved)

**Note 10:** Allow for a dominant time of at least 4μs per dominant-recessive cycle.

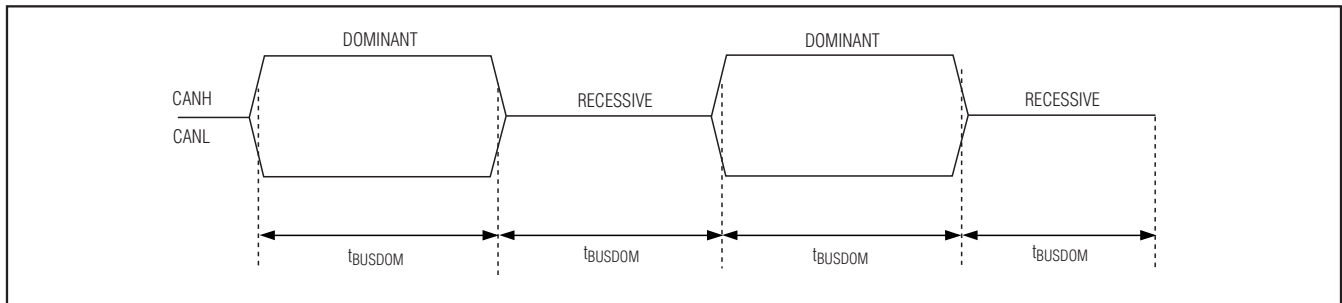

Figure 5. Wake-On-CAN Timing

when battery voltage is first applied to V<sub>BAT</sub>. When the PWON flag is set, UVNOM is cleared and sleep mode is disabled. The primary function of the PWON flag is to prevent the MAX13041 from entering sleep mode (and thereby disabling external voltage regulators) before the protocol controller establishes control through EN and  $\overline{\text{STB}}$ . The PWON flag is externally indicated as a logic-low on  $\overline{\text{ERR}}$  when the MAX13041 is placed into PWON/listen-only mode from standby mode, go-to-sleep command mode, or sleep mode. The PWON flag is cleared when the MAX13041 enters normal mode.

### Wake-Up Flag

The wake-up flag is set when a local or remote wake-up request is detected. A local wake-up request is generated when the logic level on WAKE changes and remains stable for t<sub>WAKE</sub>. A remote wake-on CAN request is generated upon the detection of two dominant bus cycles, each followed by a recessive bus

cycle (see Figure 5.) Each bus cycle must exceed t<sub>BUS(DOM)</sub>. The wake-up flag can only be set in standby mode, go-to-sleep command mode, or sleep mode. Setting the wake-up flag resets UVNOM, and wake-up requests are not detected during the UVNOM flag waiting time immediately after UVNOM has been set. The wake-up flag is immediately available as a logic-low on  $\overline{\text{ERR}}$  and RXD, provided that V<sub>I/O</sub> and V<sub>CC</sub> are both present. The wake-up flag is cleared when the MAX13041 enters normal mode.

### Wake-Up Source Flag

The wake-up source flag is set concurrently with the wake-up flag when a local wake-up event is detected. The wake-up source flag can only be set after the PWON flag has been cleared. The flag is cleared when the MAX13041 leaves normal mode and during initial power-on. The wake-up source flag is externally indicated on  $\overline{\text{ERR}}$  when the MAX13041 is in

# ±80V Fault-Protected High-Speed CAN Transceiver with Low-Power Management and Wake-On CAN

normal mode, prior to the fourth dominant-to-recessive transition on TXD. A low level on  $\overline{\text{ERR}}$  indicates a local wake-up has occurred.

## Bus Failure Flag

The bus failure flag is set when the MAX13041 detects a CAN bus short-circuit to  $V_{\text{BAT}}$ ,  $V_{\text{CC}}$ , or GND for four consecutive dominant-recessive cycles on TXD. The flag is cleared when the MAX13041 leaves normal mode. The bus failure flag is externally indicated as a logic low on  $\overline{\text{ERR}}$  in normal mode, after the fourth dominant-to-recessive transition on TXD.

## Local Failure Flag

The local failure flag indicates five separate local failure conditions (see *Fault Protection & Fail-Safes* section). When one or more local failure conditions have occurred, the local failure flag is set. The flag is cleared when the MAX13041 enters normal mode or when RXD goes logic-low while TXD is logic-high. The local failure flag is externally indicated as a logic-low on  $\overline{\text{ERR}}$  when the MAX13041 is placed into PWON/listen-only mode from normal mode.

## Wake-On CAN

The MAX13041 provides wake-on-CAN capability from sleep mode. When the MAX13041 detects two dominant bus states, each followed by a recessive state (Figure 5), the MAX13041 sets the wake-up flag and enters an operating mode determined by the state of EN and  $\overline{\text{STB}}$ . Each CAN logic state must be at least 5 $\mu\text{s}$  in duration. This wake-up detection criterion serves to prevent unintentional wake-up events due to bus faults such as  $V_{\text{BAT}}$  to CANH or an open circuit on CANL. At higher data rates (>125kbit/s), wake-up can not be guaranteed for a single, arbitrary CAN data frame. Two or more consecutive arbitrary CAN data frames may be required to ensure a successful wake-on-CAN event.

## External-Voltage Regulator Control

MAX13041 controls one or more external voltage regulators through INH, a  $V_{\text{BAT}}$ -referenced, open-drain output. When INH is logic-high, any external voltage regulators are active and power is supplied to the node. When INH is high-impedance, the typical pull-down characteristic of the voltage-regulator inhibit input pulls INH to a logic-low and disables the external voltage regulator(s).

## Fault Protection & Fail-Safes

The MAX13041 features ±80V tolerance on CAN bus lines CANH, CANL, and SPLIT. Up to +76V operation is possible on  $V_{\text{BAT}}$ , allowing for use in +42V automotive applications. Additionally, the device detects local and remote bus failures and features fail-safe modes to

prevent damage to the device or interference with CAN bus communication.

The MAX13041 detects five different local faults. When any local fault is detected, the local failure flag is set. Additionally, for faults other than bus dominant clamping, the transmitter is disabled to prevent possible damage to the device. The transmitter remains disabled until the local failure flag is cleared.

## TXD Dominant Clamping

An extended logic-low level on TXD due to hardware or software failure would ordinarily clamp the CAN bus to a dominant state, blocking communication on the entire bus. This condition is prevented by the TXD dominant time-out feature. If TXD is held low for longer than  $t_{\text{DOM}}(\text{TXD})$ , the local failure flag is set and the transmitter is disabled until the local failure flag is cleared. The TXD time-out value limits the minimum allowable bit rate to 40kbps.

## RXD Recessive Clamping

If a hardware failure clamps RXD to a logic-high level, the protocol controller assumes the CAN bus is in a recessive state at all times. This has the undesirable effect that the protocol controller assumes the bus is clear and may initiate messages that would interfere with ordinary communication. This local failure is detected by checking the state of RXD when the CAN bus is in a dominant state. If RXD does not reflect the state of the CAN bus, the local failure flag is set and the transmitter is disabled until the local failure flag is cleared.

## TXD-to-RXD Short-Circuit Detection

A short-circuit between TXD and RXD forces the bus into a permanent dominant state upon the first transmission of a dominant bit because normally the low-side driver of RXD is stronger than the microcontroller high-side driver of TXD. The MAX13041 detects this condition and prevents the resulting bus failure by setting the local failure flag and disabling the transmitter. The transmitter remains disabled until the local failure flag is cleared.

## Bus Dominant Clamping

A short-circuit fault from the CAN bus to  $V_{\text{BAT}}$ ,  $V_{\text{CC}}$ , or GND could produce a differential voltage between CANH and CANL greater than the receiver threshold, resulting in a dominant bus state. If the bus state is clamped dominant for longer than  $t_{\text{DOM}}(\text{BUS})$ , the local failure flag is set. The transmitter is not disabled by this fault and the local failure flag is cleared as soon as the bus state becomes recessive.

# ±80V Fault-Protected High-Speed CAN Transceiver with Low-Power Management and Wake-On CAN

## Thermal Shutdown Fault

The local failure flag is set when the junction temperature ( $T_J$ ) exceeds the shutdown junction temperature threshold,  $T_{J(SD)}$ . The transmitter is disabled to prevent excessive current dissipation from damaging the device. The transmitter remains disabled until  $T_J$  drops  $T_{J(SD)HYST}$  degrees, and the local failure flag is cleared.

## Recovering from Local Faults

The local failure flag is cleared and the transmitter is re-enabled whenever RXD is dominant while TXD is recessive. This situation occurs normally when the MAX13041 is receiving CAN bus data in the absence of a bus failure. In PWON/listen-only mode,  $\overline{ERR}$  changes to a logic-high to reflect the change in the local failure flag. If there is no activity on the CAN bus, the local failure flag can also be cleared by switching to normal mode from another operating mode. A typical method involves switching to PWON/listen-only mode and reading the local failure flag on  $\overline{ERR}$ . Subsequently, switch back to normal mode to clear the flag. This sequence is then repeated to verify that the failure has been resolved.

## ESD Protection

As with all Maxim devices, ESD-protection structures are incorporated on all pins to protect against electrostatic discharges encountered during handling and assembly. The CANH and CANL lines are further protected by advanced ESD structures to guard these pins from damage caused by ESD of up to  $\pm 12\text{kV}$  as measured by the Human Body Model (HBM). Protection structures prevent damage caused by ESD events in all operating modes, and when the device is unpowered.

## ESD Models

Several ESD testing standards exist for gauging the robustness of ESD structures. The ESD protection of the MAX13041 is characterized for the human body model (HBM). Figure 6 shows the model used to simulate an ESD event resulting from contact with the human body. The model consists of a 100pF storage capacitor that is charged to a high voltage, and subsequently discharged through a 1.5k $\Omega$  resistor. Figure 7 shows the current waveform when the storage capacitor is discharged into a low impedance.

## ESD Test Conditions

ESD performance depends on a variety of conditions. Please contact Maxim for a reliability report documenting test setup, methodology, and results.

## Applications Information

### Clamp-30, Type-A CAN Modules

The MAX13041 is primarily intended for automotive ECU applications where battery power is permanently supplied to the node (see Figure 8.) This type of application is referred to as a clamp-30 node. ECU modules, which are supplied by the battery only when the ignition switch is closed, are referred to as clamp-15 modules. Because clamp-30 modules are permanently supplied by battery voltage, low power consumption is an essential design requirement. The MAX13041 provides advanced power management to the entire node by controlling one or more external voltage regulators. While CAN transceivers, such as the MAX13041, operate from a supply voltage of +5V, many microprocessors are supplied by voltages of +3.3V and lower. By controlling the supply voltage regulator for the microprocessor, the MAX13041 can force a low-power sleep mode for the entire node.

### EMC Considerations

In multidrop CAN applications, it is important to maintain a direct point-to-point wiring scheme. A single pair of wires should connect each transceiver on the CAN bus, and the bus wires should be properly split-terminated with two 60 $\Omega$  resistors at each end as described in Figure 3. For best EMC performance, do not use a star topology. Any deviation from the point-to-point wiring scheme results in a stub. High-speed edges of the CAN signal reflect from the unterminated stub ends, interfering with communication on the bus. To minimize the effect of these reflections, care should be taken to minimize the length of stubs.

### Power-Supply Decoupling

Bypass  $V_{CC}$ ,  $V_{BAT}$ , and  $V_{I/O}$  to ground with 0.1 $\mu\text{F}$  ceramic capacitors. Place all capacitors as close as possible to the device.

# ±80V Fault-Protected High-Speed CAN Transceiver with Low-Power Management and Wake-On CAN

MAX13041

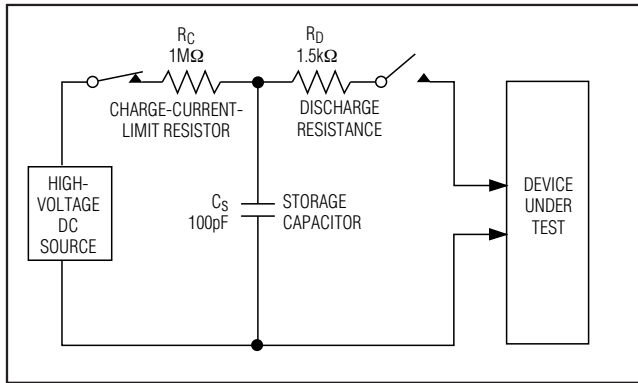

Figure 6. Human Body ESD Test Model

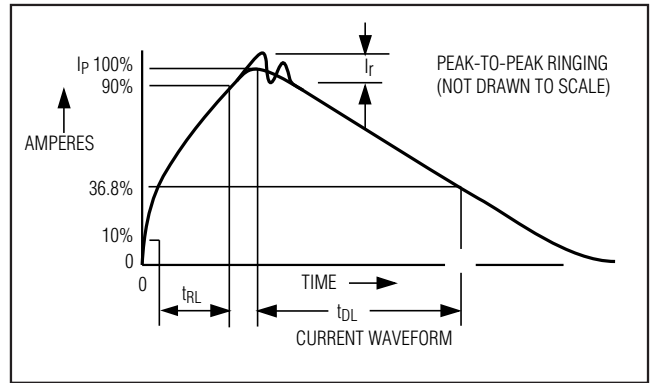

Figure 7. Human Body Model Current Waveform

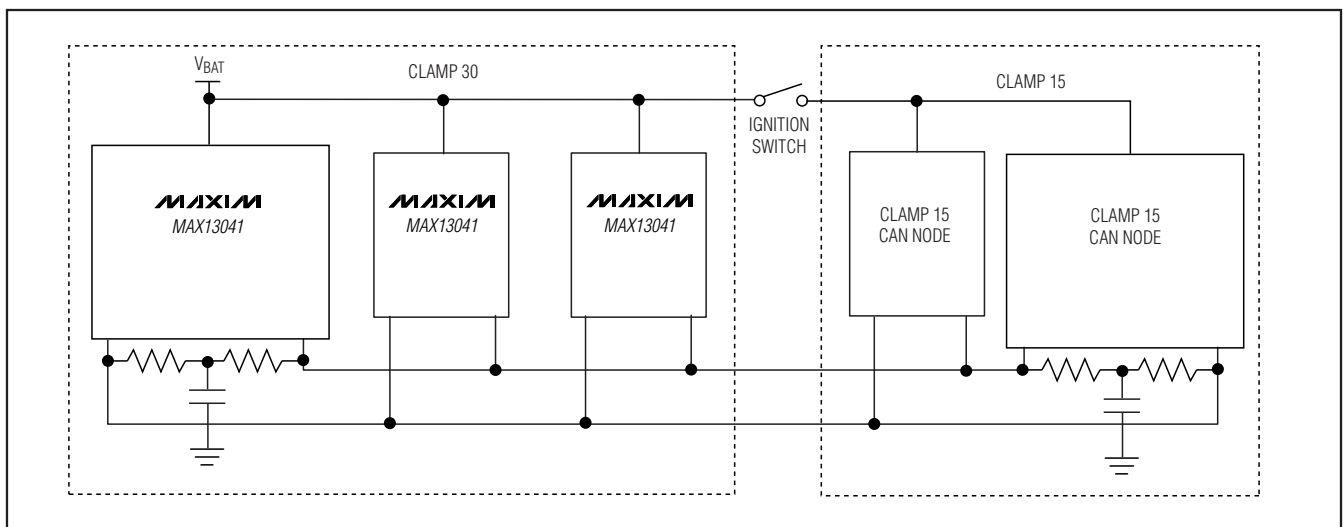

Figure 8. Typical ECU Architecture with Clamp-30 and Clamp-15 Modules

# ±80V Fault-Protected High-Speed CAN Transceiver with Low-Power Management and Wake-On CAN

## Pin Configuration

## Chip Information

PROCESS: BiCMOS

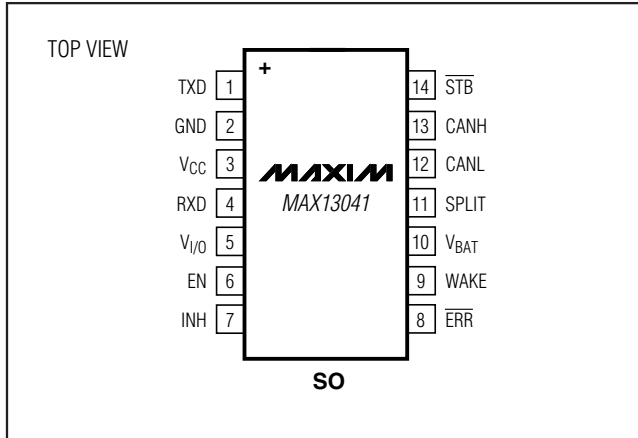

# ±80V Fault-Protected High-Speed CAN Transceiver with Low-Power Management and Wake-On CAN

## Functional Diagram

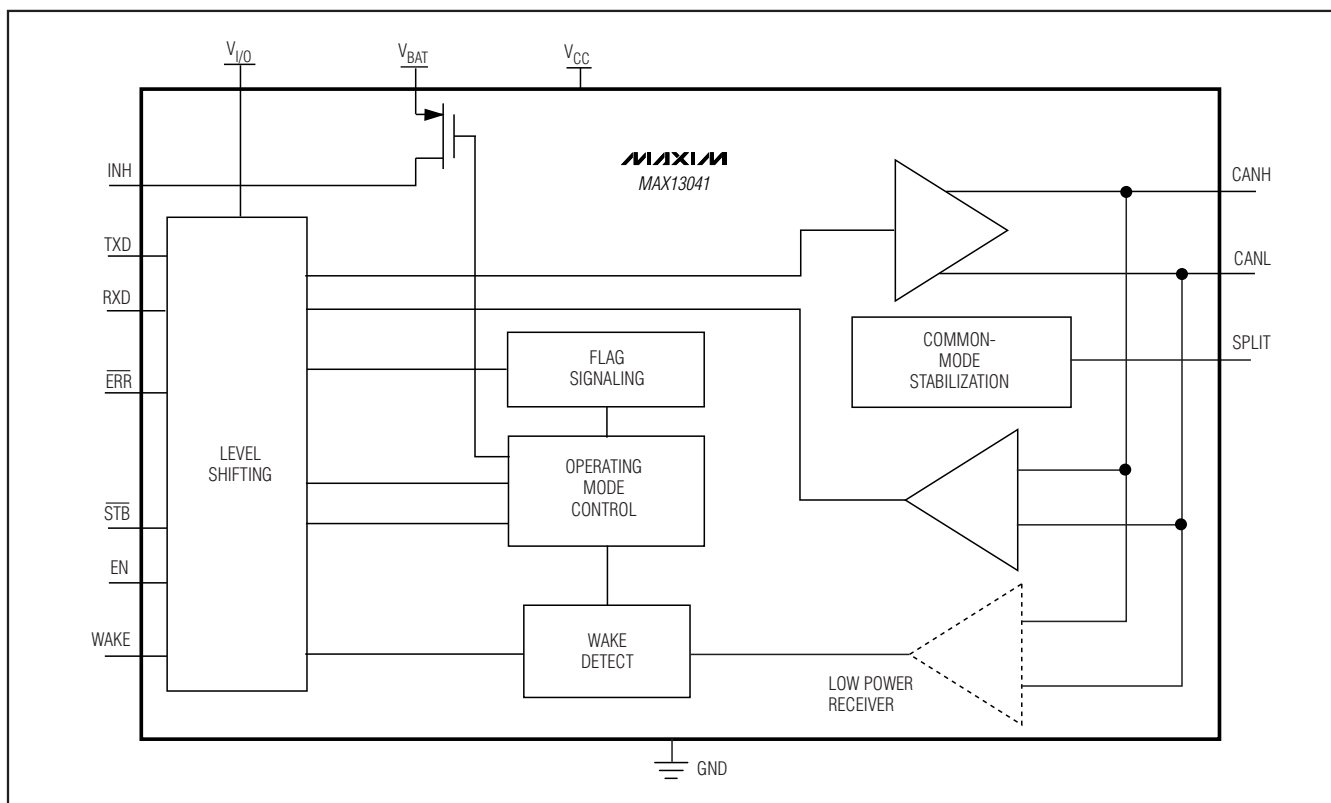

**MAX13041**

## Package Information

For the latest package outline information and land patterns, go to [www.maxim-ic.com/packages](http://www.maxim-ic.com/packages).

PACKAGE TYPE	PACKAGE CODE	DOCUMENT NO.
14 SO	S14M-7	<a href="#">21-0041</a>

# **$\pm 80V$ Fault-Protected High-Speed CAN Transceiver with Low-Power Management and Wake-On CAN**

## **Revision History**



<b>REVISION NUMBER</b>	<b>REVISION DATE</b>	<b>DESCRIPTION</b>	<b>PAGES CHANGED</b>
1	11/07	Changed <i>Absolute Maximum Ratings</i> and <i>Electrical Characteristics</i> sections	2, 4, 5, 12
2	12/08	Added automotive part number	1

Maxim cannot assume responsibility for use of any circuitry other than circuitry entirely embodied in a Maxim product. No circuit patent licenses are implied. Maxim reserves the right to change the circuitry and specifications without notice at any time.

20 \_\_\_\_\_ **Maxim Integrated Products, 120 San Gabriel Drive, Sunnyvale, CA 94086 408-737-7600**

## Looking for pricing, stock, or lifecycle information?

Click below to explore more details on WIN SOURCE:

-  [View MAX13041ASD+ on WIN SOURCE](#)
-  [Maxim Integrated Information](#)

## Optimize Your Supply Chain with WIN SOURCE Solutions

-  Global Sourcing Solution
-  Obsolete Management
-  Cost Control Management
-  Shortage Management
-  Alternative Solution
-  Excess Inventory Management