



**THE DATASHEET OF  
MAX13003EEUE+**





# Ultra-Low-Voltage Level Translators

## General Description

The MAX13000E–MAX13005E 6-channel level translators provide the level shifting necessary to allow data transfer in multivoltage systems. Externally applied voltages,  $V_{CC}$  and  $V_L$ , set the logic levels on either side of the device. Logic signals present on the  $V_L$  side of the device appear as higher voltage logic signals on the  $V_{CC}$  side of the device, and vice-versa.

The MAX13000E–MAX13005E feature a low  $V_{CC}$  and  $V_L$  quiescent supply current less than 4 $\mu$ A. The MAX13000E–MAX13005E also have  $\pm 15$ kV ESD protection on the I/O  $V_{CC}$  side for greater protection in applications that route signals externally. The ESD protection is specified using the Human Body Model (HBM). The MAX13000E/MAX13001E/MAX13002E operate at a guaranteed 230kbps data rate. The MAX13003E/MAX13004E/MAX13005E operate at a guaranteed 20Mbps data rate when  $V_{CC} > +1.65$ V.

The MAX13000E/MAX13003E are bidirectional level translators, allowing data translation in either direction ( $V_L \leftrightarrow V_{CC}$ ) on any single data line without a DIRECTION input. The MAX13001E/MAX13002E/MAX13004E/MAX13005E unidirectional level translators level shift data in one direction ( $V_L \rightarrow V_{CC}$  or  $V_{CC} \rightarrow V_L$ ) on any single data line. The MAX13001E/MAX13002E/MAX13004E/MAX13005E unidirectional translators' inputs have the capability to interface with both CMOS and open-drain (OD) outputs. For more information see the *Ordering Information*, *Selector Guide*, and the *Input-Driver Requirements* sections.

The MAX13000E–MAX13005E operate with +0.9V to +3.6V  $V_L$  voltages and +1.5V to +3.6V  $V_{CC}$  voltages. The MAX13000E–MAX13005E are available in 16-bump UCSP™ and 16-pin TSSOP packages, and are specified over the extended -40°C to +85°C operating temperature range.

## Applications

- CMOS Logic-Level Translation
- Open-Drain I/O Translation
- OD-to-CMOS Signal Conversion
- Low-Voltage ASIC Level Translation
- Cell Phones
- SPI™ and MICROWIRE® Level Translation
- Smart-Card Readers
- Portable POS Systems
- Portable Communication Devices
- Low-Cost Serial Interfaces
- Telecommunications Equipment

## Features

- ◆ **Guaranteed Data-Rate Options**
  - 230kbps (MAX13000E/MAX13001E/MAX13002E)
  - 20Mbps (MAX13003E/MAX13004E/MAX13005E)
- ◆ **Bidirectional Level Translation Without a DIRECTION Input**
- ◆ **Operational Down to +0.9V on  $V_L$  and +1.5V on  $V_{CC}$**
- ◆  **$\pm 15$ kV ESD Protection on I/O  $V_{CC}$  Lines per HBM**
- ◆ **Low <4 $\mu$ A Quiescent Current**
- ◆ **Enable/Shutdown Control**
- ◆ **2mm x 2mm, 16-Bump UCSP and Lead Packaging Options**
- ◆ **CMOS or Open-Drain Outputs Interface Capability**

UCSP is a trademark of Maxim Integrated Products, Inc.  
SPI is a trademark of Motorola, Inc.  
MICROWIRE is a registered trademark of National Semiconductor Corp.

## Ordering Information

PART	TEMP RANGE	PIN-PACKAGE
MAX13000EEUE+	-40°C to +85°C	16 TSSOP

+Denotes a lead(Pb)-free/RoHS-compliant package.

Ordering Information continued at end of data sheet.

## Pin Configurations

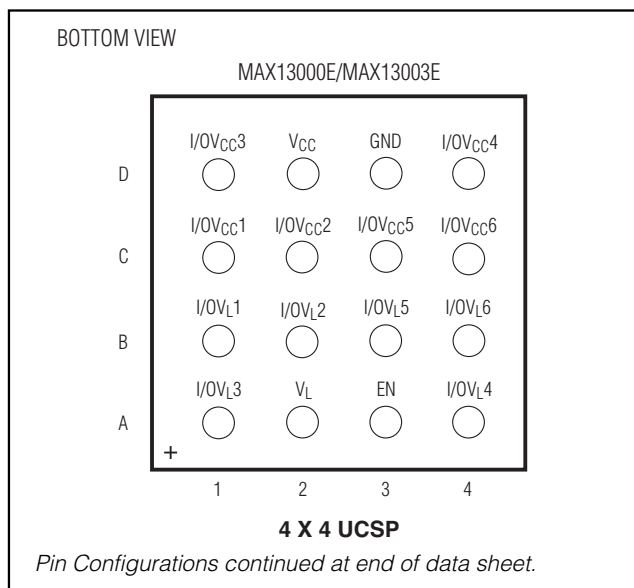

Typical Operating Circuits and Selector Guide appear at end of data sheet.



# Ultra-Low-Voltage Level Translators

## ABSOLUTE MAXIMUM RATINGS

Voltages referenced to GND.

V <sub>CC</sub> .....	-0.3V to +4V
V <sub>L</sub> .....	-0.3V to +4V
I/OV <sub>CC</sub> .....	-0.3V to (V <sub>CC</sub> + 0.3V)
I/OV <sub>L</sub> .....	-0.3V to (V <sub>L</sub> + 0.3V)
EN.....	-0.3V to (V <sub>L</sub> + 0.3V)
Short-Circuit Duration I/OV <sub>L</sub> , I/OV <sub>CC</sub> to GND.....	Continuous

Continuous Power Dissipation (T<sub>A</sub> = +70°C)

16-Pin TSSOP (derate 9.4mW/°C at +70°C) .....	755mW
16-Bump UCSP (derate 8.2mW/°C at +70°C) .....	659mW
Operating Temperature Range .....	-40°C to +85°C
Junction Temperature.....	+150°C
Storage Temperature Range.....	-65°C to +150°C
Lead Temperature (soldering, 10s).....	+300°C

Stresses beyond those listed under "Absolute Maximum Ratings" may cause permanent damage to the device. These are stress ratings only, and functional operation of the device at these or any other conditions beyond those indicated in the operational sections of the specifications is not implied. Exposure to absolute maximum rating conditions for extended periods may affect device reliability.

## ELECTRICAL CHARACTERISTICS

(V<sub>CC</sub> = +1.5V to +3.6V, V<sub>L</sub> = +0.9V to V<sub>CC</sub>, C<sub>I/OV<sub>L</sub></sub> ≤ 15pF, C<sub>I/OV<sub>CC</sub></sub> ≤ 50pF, T<sub>A</sub> = -40°C to +85°C, unless otherwise noted. Typical values are at T<sub>A</sub> = +25°C.) (Notes 1, 4)

PARAMETER	SYMBOL	CONDITIONS		MIN	TYP	MAX	UNITS
V <sub>L</sub> Supply Range	V <sub>L</sub>	V <sub>L</sub> ≤ V <sub>CC</sub> (Note 2)		0.9		V <sub>CC</sub>	V
V <sub>CC</sub> Supply Range	V <sub>CC</sub>	(Note 2)		1.5		3.6	V
Supply Current from V <sub>CC</sub> (Note 3)	I <sub>QVCC</sub>	T <sub>A</sub> = +25°C				4	μA
		T <sub>A</sub> = +85°C				40	
Supply Current from V <sub>L</sub> (Note 3)	I <sub>QVL</sub>	T <sub>A</sub> = +25°C	(Note 3)		1	5	μA
			V <sub>L</sub> < V <sub>CC</sub> - 0.2V			2	
		T <sub>A</sub> = +85°C	(Note 3)		4	40	
			V <sub>L</sub> < V <sub>CC</sub> - 0.2V			20	
V <sub>CC</sub> Shutdown Supply Current (Note 3)	I <sub>SHDN-VCC</sub>	EN = GND, T <sub>A</sub> = +25°C				2	μA
		EN = GND, T <sub>A</sub> = +85°C				20	
V <sub>L</sub> Shutdown Supply Current (Note 3)		T <sub>A</sub> = +25°C	V <sub>L</sub> < V <sub>CC</sub> - 0.2V, EN = GND			2	μA
			EN = GND		1	4	
		T <sub>A</sub> = +85°C	V <sub>L</sub> < V <sub>CC</sub> - 0.2V, EN = GND			20	
			EN = GND			40	
I/O Tri-State Output Leakage Current		I/O V <sub>L</sub> , I/O V <sub>CC</sub> , EN = GND	T <sub>A</sub> = +25°C			0.35	μA
			T <sub>A</sub> = +85°C			1	
I/O Tri-States Output Leakage Current		V <sub>L</sub> < V <sub>CC</sub> - 0.2V, I/O V <sub>L</sub> , I/O V <sub>CC</sub> , EN = GND	T <sub>A</sub> = +25°C			0.2	μA
			T <sub>A</sub> = +85°C			0.5	
EN Input Leakage Current			T <sub>A</sub> = +25°C			0.35	μA
			T <sub>A</sub> = +85°C			1	

# Ultra-Low-Voltage Level Translators

**MAX13000E-MAX13005E**

## ELECTRICAL CHARACTERISTICS (continued)

( $V_{CC} = +1.5V$  to  $+3.6V$ ,  $V_L = +0.9V$  to  $V_{CC}$ ,  $C_{I/OVL} \leq 15pF$ ,  $C_{I/OVCC} \leq 50pF$ ,  $T_A = -40^\circ C$  to  $+85^\circ C$ , unless otherwise noted. Typical values are at  $T_A = +25^\circ C$ .) (Notes 1, 4)

PARAMETER	SYMBOL	CONDITIONS	MIN	TYP	MAX	UNITS
<b>LOGIC-LEVEL THRESHOLDS</b>						
I/OV <sub>L</sub> _ Input-Voltage-High Threshold	V <sub>IHL</sub>				$2/3 \times V_L$	V
I/OV <sub>L</sub> _ Input-Voltage-Low Threshold	V <sub>ILL</sub>		$1/3 \times V_L$			V
I/OV <sub>CC</sub> _ Input-Voltage-High Threshold	V <sub>IHC</sub>				$2/3 \times V_{CC}$	V
I/OV <sub>CC</sub> _ Input-Voltage-Low Threshold	V <sub>ILC</sub>		$1/3 \times V_{CC}$			V
EN Input-Voltage-High Threshold	V <sub>IHEN</sub>				$2/3 \times V_L$	V
EN Input-Voltage-Low Threshold	V <sub>ILEN</sub>		$1/3 \times V_L$			V
I/OV <sub>L</sub> _ Output-Voltage High	V <sub>OHL</sub>	I/OV <sub>L</sub> _ source current = 20 $\mu$ A	$V_L - 0.25$			V
I/OV <sub>L</sub> _ Output-Voltage Low	V <sub>OLL</sub>	MAX13002E/MAX13005E, OV <sub>L</sub> _ sink current = 1 $\mu$ A			0.3	V
		MAX13000E/MAX13001E/MAX13003E/MAX13004E, I/OV <sub>L</sub> _ sink current = 20 $\mu$ A			0.25	
I/OV <sub>CC</sub> _ Output-Voltage High	V <sub>OHC</sub>	I/OV <sub>CC</sub> _ source current = 20 $\mu$ A	$V_{CC} - 0.25$			V
I/OV <sub>CC</sub> _ Output-Voltage Low	V <sub>OLC</sub>	MAX13001E/MAX13004E, OV <sub>CC</sub> _ sink current = 1 $\mu$ A			0.3	V
		MAX13000E/MAX13002E/MAX13003E/MAX13005E, I/OV <sub>CC</sub> _ sink current = 20 $\mu$ A			0.25	
<b>OUTPUT CURRENTS</b>						
Output Sink Current During Transient ( $V_{CC}$ Side)		$V_{CC} = +1.65V$ , MAX13003E/MAX13004E/MAX13005E		25		mA
		$V_{CC} = +1.65V$ , MAX13000E/MAX13001E/MAX13002E		1		
Output Sink Current During Transient ( $V_L$ Side)		$V_L = +1.2V$ , $V_{CC} = +1.65V$ , MAX13003E/MAX13004E/MAX13005E		30		mA
		$V_L = +1.2V$ , $V_{CC} = +1.65V$ , MAX13000E/MAX13001E/MAX13002E		1		

# Ultra-Low-Voltage Level Translators

## ELECTRICAL CHARACTERISTICS (continued)

( $V_{CC} = +1.5V$  to  $+3.6V$ ,  $V_L = +0.9V$  to  $V_{CC}$ ,  $C_{I/OVL} \leq 15pF$ ,  $C_{I/OVCC} \leq 50pF$ ,  $T_A = -40^\circ C$  to  $+85^\circ C$ , unless otherwise noted. Typical values are at  $T_A = +25^\circ C$ .) (Notes 1, 4)

PARAMETER	SYMBOL	CONDITIONS	MIN	TYP	MAX	UNITS
Output Source Current During Transient ( $V_{CC}$ Side)		$V_{CC} = +1.65V$ , MAX13003E/MAX13004E/MAX13005E		22		mA
		$V_{CC} = +1.65V$ , MAX13000E/MAX13001E/MAX13002E		1		
Output Source Current During Transient ( $V_L$ Side)		$V_L = +1.2V$ , $V_{CC} = +1.65V$ , MAX13003E/MAX13004E/MAX13005E		25		mA
		$V_L = +1.2V$ , $V_{CC} = +1.65V$ , MAX13000E/MAX13001E/MAX13002E		1		
<b>ESD PROTECTION</b>						
$I/OV_{CC\_}$		Human Body Model		$\pm 15$		kV
		Air-Gap Discharge (IEC61000-4-2)		$\pm 10$		
		Contact Discharge (IEC61000-4-2)		$\pm 8$		

## TIMING CHARACTERISTICS

( $V_{CC} = +1.5V$  to  $+3.6V$ ,  $V_L = +0.9V$  to  $V_{CC}$ ,  $C_{I/OVL} \leq 15pF$ ,  $C_{I/OVCC} \leq 50pF$ ,  $T_A = -40^\circ C$  to  $+85^\circ C$ , unless otherwise noted. Typical values are at  $T_A = +25^\circ C$ .) (Notes 1, 4)

PARAMETER	SYMBOL	CONDITIONS	MIN	TYP	MAX	UNITS
$I/OV_{CC\_}$ Rise Time	$t_{RVCC}$	$C_{I/OVCC} = 50pF$ , MAX13003E/MAX13004E/MAX13005E, $V_{CC} = +1.65V$ , Figures 1a, 1b			15	ns
		$C_{I/OVCC} = 50pF$ , MAX13003E/MAX13004E/MAX13005E, $V_{CC} = +1.5V$ , Figures 1a, 1b			15	
		$C_{I/OVCC} = 50pF$ , MAX13000E/MAX13001E/MAX13002E, Figures 1a, 1b	400		1400	
$I/OV_{CC\_}$ Fall Time	$t_{FVCC}$	$C_{I/OVCC} = 50pF$ , MAX13003E/MAX13004E/MAX13005E, $V_{CC} = +1.65V$ , Figures 1a, 1b			15	ns
		$C_{I/OVCC} = 50pF$ , MAX13003E/MAX13004E/MAX13005E, $V_{CC} = +1.5V$ , Figures 1a, 1b			15	
		$C_{I/OVCC} = 50pF$ , MAX13000E/MAX13001E/MAX13002E, Figures 1a, 1b	400		1400	

# Ultra-Low-Voltage Level Translators

**MAX13000E-MAX13005E**

## TIMING CHARACTERISTICS (continued)

( $V_{CC} = +1.5V$  to  $+3.6V$ ,  $V_L = +0.9V$  to  $V_{CC}$ ,  $C_{I/OVL} \leq 15pF$ ,  $C_{I/OVCC} \leq 50pF$ ,  $T_A = -40^\circ C$  to  $+85^\circ C$ , unless otherwise noted. Typical values are at  $T_A = +25^\circ C$ .) (Notes 1, 4)

PARAMETER	SYMBOL	CONDITIONS	MIN	TYP	MAX	UNITS
I/OVL_ Rise Time	t <sub>RVL</sub>	C <sub>I/OVL</sub> = 50pF, MAX13003E/MAX13004E/MAX13005E, V <sub>CC</sub> = +1.65V, Figures 2a, 2b			15	ns
		C <sub>I/OVL</sub> = 15pF, MAX13003E/MAX13004E/MAX13005E, V <sub>CC</sub> = +1.5V, Figures 2a, 2b			15	
		C <sub>I/OVL</sub> = 50pF, MAX13000E/MAX13001E/MAX13002E, Figures 2a, 2b	300		1200	
I/OVL_ Fall Time	t <sub>FVL</sub>	C <sub>I/OVL</sub> = 50pF, MAX13003E/MAX13004E/MAX13005E, V <sub>CC</sub> = +1.65V, Figures 2a, 2b			15	ns
		C <sub>I/OVL</sub> = 15pF, MAX13003E/MAX13004E/MAX13005E, V <sub>CC</sub> = +1.5V, Figures 2a, 2b			15	
		C <sub>I/OVL</sub> = 50pF, MAX13000E/MAX13001E/MAX13002E, Figures 2a, 2b	300		1200	
Propagation Delay (Driving I/OVL_)	I/OVL-VCC	C <sub>I/OVCC</sub> = 50pF, MAX13003E/MAX13004E/MAX13005E, Figures 1a, 1b			20	ns
		C <sub>I/OVCC</sub> = 50pF, MAX13000E/MAX13001E/MAX13002E, Figures 1a, 1b			1000	
Propagation Delay (Driving I/OVCC_)	I/OVCC-VL	V <sub>CC</sub> > +1.65V, C <sub>I/OVL</sub> = 50pF, MAX13003E/MAX13004E/MAX13005E, Figures 2a, 2b			20	ns
		V <sub>CC</sub> = 1.5V, C <sub>I/OVL</sub> = 15pF, MAX13003E/MAX13004E/MAX13005E, Figures 2a, 2b			20	
		C <sub>I/OVL</sub> = 50pF, MAX13000E/MAX13001E/MAX13002E, Figures 2a, 2b			1000	
Propagation Delay from I/OVL_ to I/OVCC_ after EN (Note 5)	t <sub>EN-VCC</sub>	C <sub>I/OVCC</sub> = 50pF, CMOS output, Figure 3			2	μs
		C <sub>I/OVCC</sub> = 50pF, OD output, Figure 3			6	

# Ultra-Low-Voltage Level Translators

## TIMING CHARACTERISTICS (continued)

( $V_{CC} = +1.5V$  to  $+3.6V$ ,  $V_L = +0.9V$  to  $V_{CC}$ ,  $C_{I/OVL} \leq 15pF$ ,  $C_{I/OVCC} \leq 50pF$ ,  $T_A = -40^\circ C$  to  $+85^\circ C$ , unless otherwise noted. Typical values are at  $T_A = +25^\circ C$ .) (Notes 1, 4)

PARAMETER	SYMBOL	CONDITIONS	MIN	TYP	MAX	UNITS
Propagation Delay from I/OVCC to I/OVL after EN (Note 5)	$t_{EN-VL}$	$C_{I/OVL} = 50pF$ , CMOS output, Figure 4			2	$\mu s$
		$C_{I/OVL} = 50pF$ , OD output, Figure 4			6	
Channel-to-Channel Skew	$t_{SKEW}$	Each translator equally loaded, MAX13003E/MAX13004E/MAX13005E			$\pm 5$	ns
		Each translator equally loaded, MAX13000E/MAX13001E/MAX13002E			$\pm 250$	
Part-to-Part Skew (Note 6)	$t_{PPSKEW}$	$C_{I/OVL} = 15pF$ , $C_{I/OVCC} = 15pF$ , $V_L = +1.8V$ , $V_{CC} = +2V$ , $\Delta T = +5^\circ C$ , MAX13003E/MAX13004E/MAX13005E			10	ns
Maximum Data Rate		MAX13003E/MAX13004E/MAX13005E $V_{CC} > +1.65V$ , $C_{I/OVL} = 50pF$ , $C_{I/OVCC} = 50pF$	20			Mbps
		MAX13000E/MAX13001E/MAX13002E $C_{I/OVL} = 50pF$ , $C_{I/OVCC} = 50pF$	230			kbps

**Note 1:** All devices are 100% production tested at  $T_A = +25^\circ C$ . Limits are guaranteed by design over the entire temperature range.

**Note 2:**  $V_L$  must be less than or equal to  $V_{CC}$  during normal operation. However,  $V_L$  can be greater than  $V_{CC}$  during startup and shutdown conditions.

**Note 3:** This consumption is referred to as no signal transmission.

**Note 4:** Guaranteed by design with an input signal full swing, rise/fall time  $\leq 3ns$ , source resistance is  $50\Omega$ .

**Note 5:** Enable input signal full swing and rise/fall time  $\leq 50ns$ .

**Note 6:** Guaranteed by design, not production tested.

## Typical Operating Characteristics

( $V_{CC} = +3.3V$ ,  $V_L = +0.9V$ ,  $T_A = +25^\circ C$ , MAX13003E.)

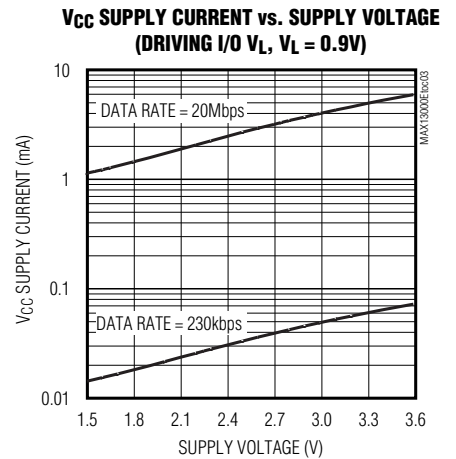
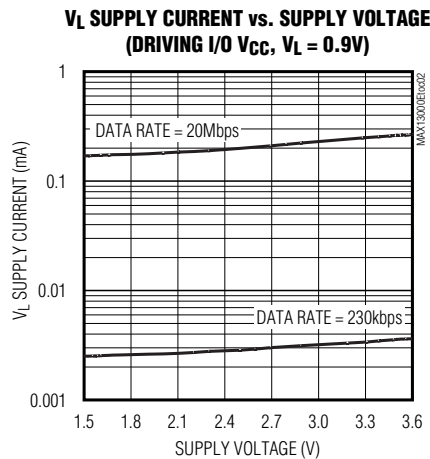
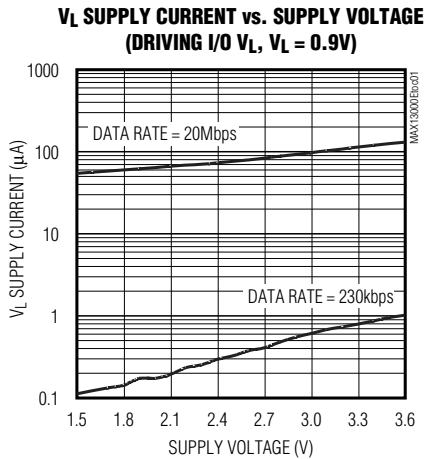

# Ultra-Low-Voltage Level Translators

## Typical Operating Characteristics (continued)

( $V_{CC} = +3.3V$ ,  $V_L = +0.9V$ ,  $T_A = +25^\circ C$ , MAX13003E.)

MAX13000E-MAX13005E

**$V_{CC}$  SUPPLY CURRENT vs. SUPPLY VOLTAGE**  
(DRIVING I/O  $V_{CC}$ ,  $V_L = +0.9V$ )

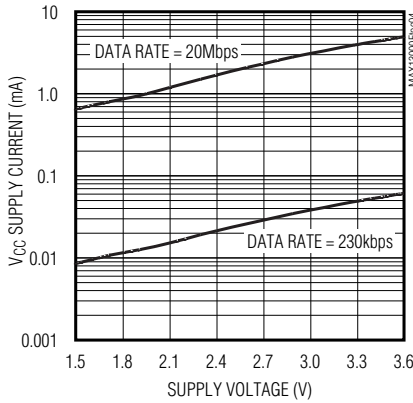

**$V_L$  SUPPLY CURRENT vs. TEMPERATURE**  
(DRIVING I/O  $V_{CC}$ ,  $V_{CC} = +3.3V$ ,  $V_L = +0.9V$ )

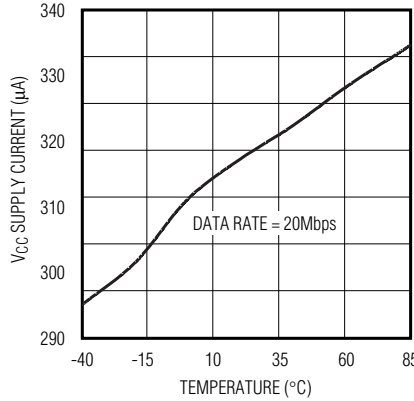

**$V_{CC}$  SUPPLY CURRENT vs. TEMPERATURE**  
(DRIVING I/O  $V_{CC}$ ,  $V_{CC} = +3.3V$ ,  $V_L = +0.9V$ )

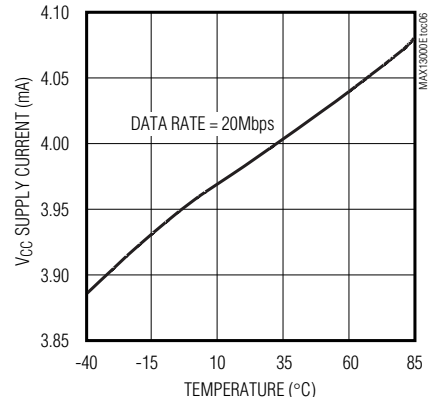

**$V_L$  SUPPLY CURRENT vs. CAPACITIVE LOAD ON I/O  $V_{CC}$**   
(DRIVING I/O  $V_L$ ,  $V_{CC} = 3.3V$ ,  $V_L = +0.9V$ )

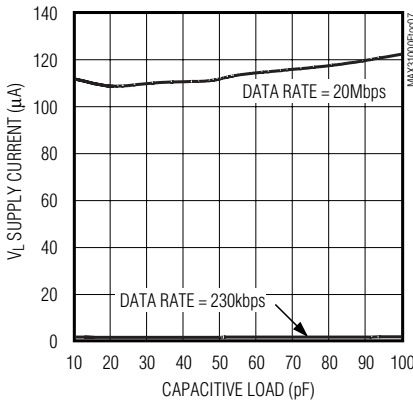

**$V_{CC}$  SUPPLY CURRENT vs. CAPACITIVE LOAD ON I/O  $V_{CC}$**   
(DRIVING I/O  $V_L$ ,  $V_{CC} = 3.3V$ ,  $V_L = +0.9V$ )

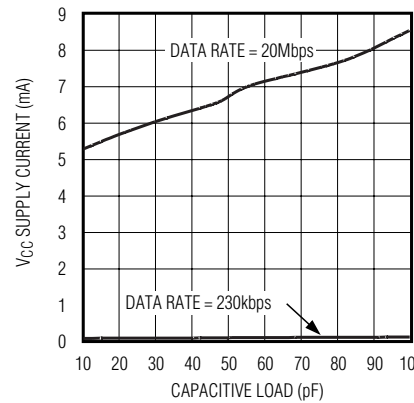

**RISE/FALL TIME vs. CAPACITIVE LOAD ON I/O  $V_{CC}$**   
(DRIVING I/O  $V_L$ ,  $V_{CC} = 3.3V$ ,  $V_L = +0.9V$ )

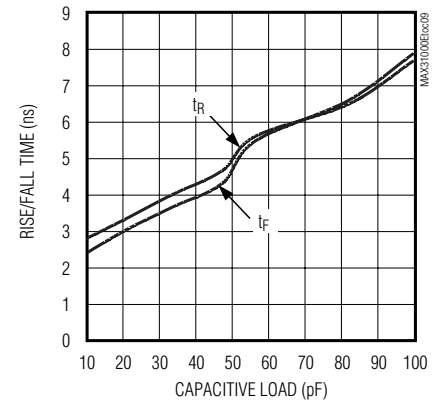

**RISE/FALL TIME vs. CAPACITIVE LOAD ON I/O  $V_L$**   
(DRIVING I/O  $V_{CC}$ ,  $V_{CC} = 3.3V$ ,  $V_L = +0.9V$ )

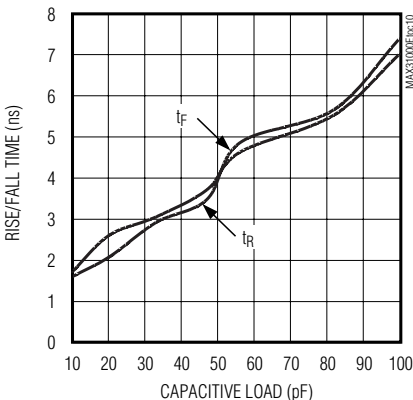

**PROPAGATION DELAY vs. CAPACITIVE LOAD ON I/O  $V_{CC}$**   
(DRIVING I/O  $V_L$ ,  $V_{CC} = 3.3V$ ,  $V_L = +0.9V$ )

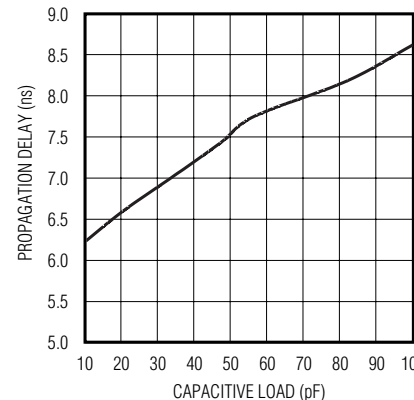

**PROPAGATION DELAY vs. CAPACITIVE LOAD ON I/O  $V_L$**   
(DRIVING I/O  $V_{CC}$ ,  $V_{CC} = 3.3V$ ,  $V_L = +0.9V$ )

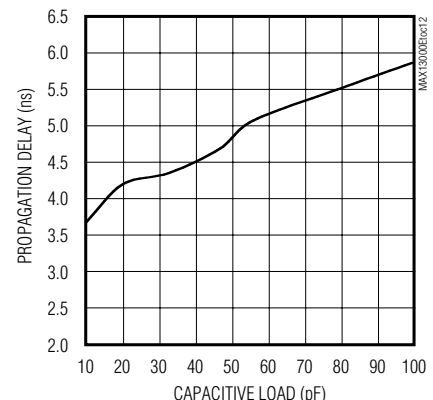

# Ultra-Low-Voltage Level Translators

## Typical Operating Characteristics (continued)

( $V_{CC} = +3.3V$ ,  $V_L = +0.9V$ ,  $T_A = +25^\circ C$ , MAX13003E.)

**OD RAIL-TO-RAIL DRIVING (MAX13005E)**  
 (DRIVING I/OV<sub>L</sub>,  $V_{CC} = +3.3V$ ,  
 $V_L = +0.9V$ ,  $C_{I/OVCC} = 56pF$ ,  
 DATA RATE = 230Mbps,  $R_{PULLUP} = 1k\Omega$ )

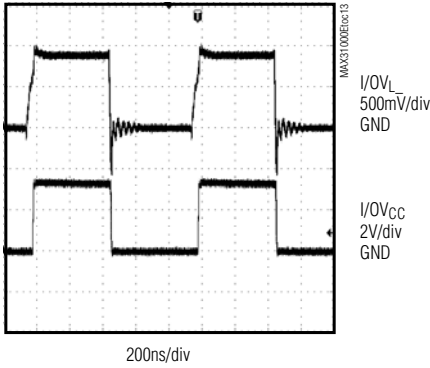

**OD RAIL-TO-RAIL DRIVING (MAX13002E)**  
 (DRIVING I/OV<sub>L</sub>,  $V_{CC} = +3.3V$ ,  
 $V_L = +0.9V$ ,  $C_{I/OVCC} = 56pF$ ,  
 DATA RATE = 230kbps,  $R_{PULLUP} = 15k\Omega$ )

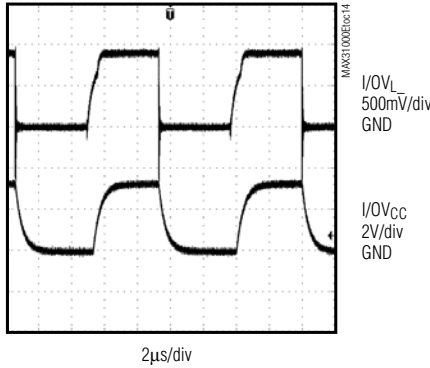

**RAIL-TO-RAIL DRIVING**  
 (DRIVING I/OV<sub>L</sub>,  $V_{CC} = +3.3V$ ,  $V_L = +0.9V$ ,  
 $C_{I/OVCC} = 50pF$ , DATA RATE = 230kbps)

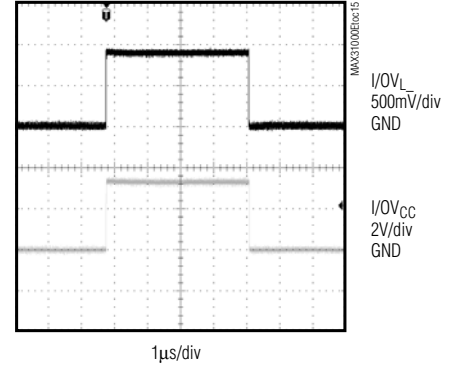

**RAIL-TO-RAIL DRIVING**  
 (DRIVING I/OV<sub>L</sub>,  $V_{CC} = +3.3V$ ,  $V_L = +0.9V$ ,  
 $C_{I/OVCC} = 50pF$ , DATA RATE = 4Mbps)

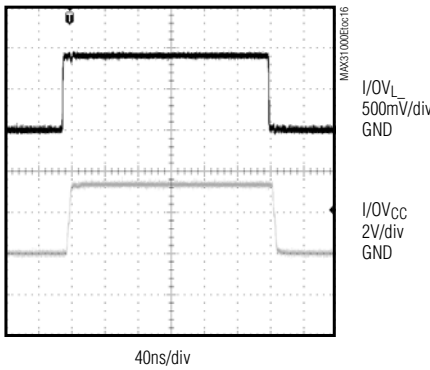

**RAIL-TO-RAIL DRIVING**  
 (DRIVING I/OV<sub>L</sub>,  $V_{CC} = +3.3V$ ,  $V_L = +0.9V$ ,  
 $C_{I/OVCC} = 50pF$ , DATA RATE = 20Mbps)

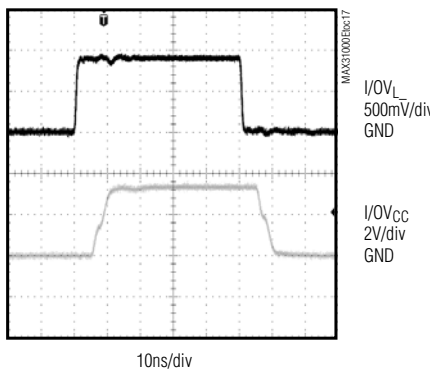

**$V_{CC} + V_L$  SUPPLY CURRENT vs. FREQUENCY**  
 (DRIVING I/OV<sub>L</sub>,  $V_{CC} = +3.3V$ ,  $V_L = +0.9V$ )

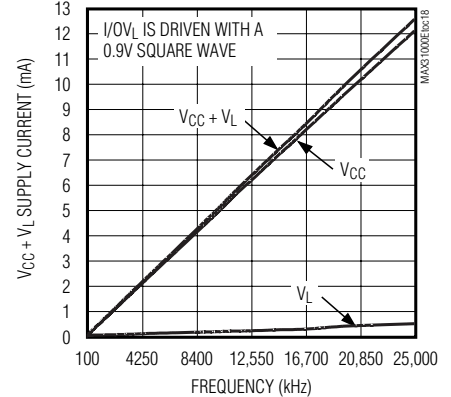

**$V_{CC} + V_L$  SUPPLY CURRENT vs. FREQUENCY**  
 (DRIVING I/OV<sub>CC</sub>,  $V_{CC} = +3.3V$ ,  $V_L = +0.9V$ )

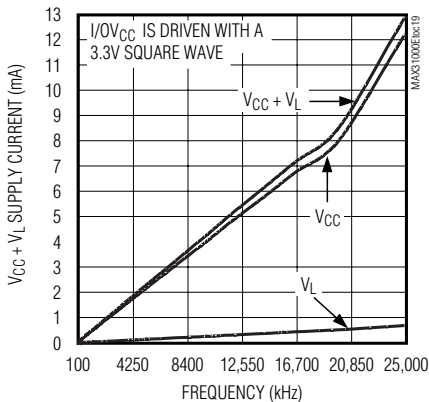

**$V_{OHL}$  vs.  $I_{OHL}$  FOR  $V_L$  SIDE**  
 ( $V_{CC} = 3.3V$ )

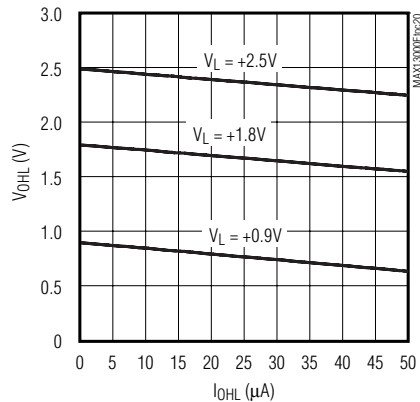

**$V_{OLL}$  vs.  $I_{OLL}$  FOR  $V_L$  SIDE**  
 ( $V_{CC} = 3.3V$ )

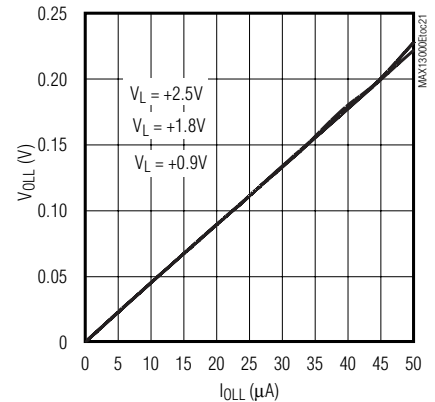

# Ultra-Low-Voltage Level Translators

## Typical Operating Characteristics (continued)

( $V_{CC} = +3.3V$ ,  $V_L = +0.9V$ ,  $T_A = +25^\circ C$ , MAX13003E.)

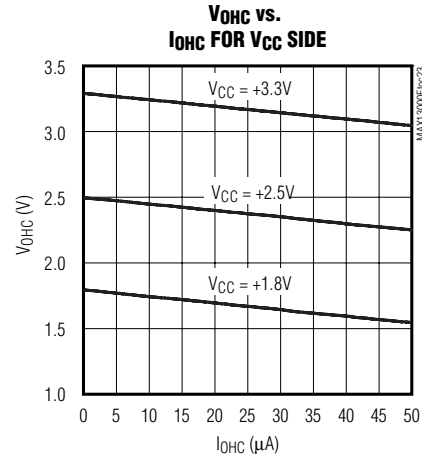
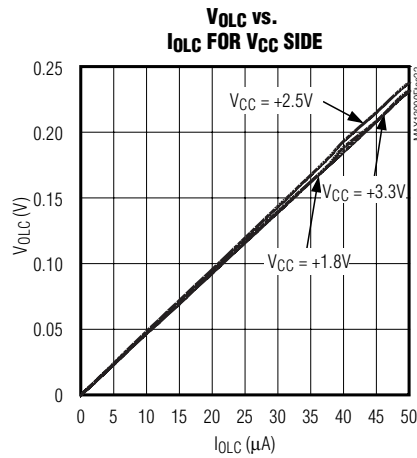

## Pin Descriptions

MAX13000E-MAX13005E

### MAX13000E/MAX13003E

PIN		NAME	FUNCTION
TSSOP	UCSP		
1	B1	I/OV <sub>L</sub> 1	CMOS Input/Output 1, Referenced to V <sub>L</sub>
2	B2	I/OV <sub>L</sub> 2	CMOS Input/Output 2, Referenced to V <sub>L</sub>
3	A1	I/OV <sub>L</sub> 3	CMOS Input/Output 3, Referenced to V <sub>L</sub>
4	A2	V <sub>L</sub>	Logic Input Voltage, $+0.9V \leq V_L \leq V_{CC}$ . Bypass V <sub>L</sub> to GND with a 0.1 $\mu F$ capacitor.
5	A3	EN	Enable Input. When EN is pulled low, I/O V <sub>CC</sub> 1 to I/O V <sub>CC</sub> 6 and I/O V <sub>L</sub> 1 to I/O V <sub>L</sub> 6 are tri-stated. Drive EN high (V <sub>L</sub> ) for normal operation.
6	A4	I/OV <sub>L</sub> 4	CMOS Input/Output 4, Referenced to V <sub>L</sub>
7	B3	I/OV <sub>L</sub> 5	CMOS Input/Output 5, Referenced to V <sub>L</sub>
8	B4	I/OV <sub>L</sub> 6	CMOS Input/Output 6, Referenced to V <sub>L</sub>
9	C4	I/OV <sub>CC</sub> 6	CMOS Input/Output 6, Referenced to V <sub>CC</sub>
10	C3	I/OV <sub>CC</sub> 5	CMOS Input/Output 5, Referenced to V <sub>CC</sub>
11	D4	I/OV <sub>CC</sub> 4	CMOS Input/Output 4, Referenced to V <sub>CC</sub>
12	D3	GND	Ground
13	D2	V <sub>CC</sub>	V <sub>CC</sub> Input Voltage, $+1.5V \leq V_{CC} \leq 3.6V$ . Bypass V <sub>CC</sub> to GND with a 0.1 $\mu F$ capacitor. For full ESD protection, use a 1 $\mu F$ bypass capacitor on V <sub>CC</sub> .
14	D1	I/OV <sub>CC</sub> 3	CMOS Input/Output 3, Referenced to V <sub>CC</sub>
15	C2	I/OV <sub>CC</sub> 2	CMOS Input/Output 2, Referenced to V <sub>CC</sub>
16	C1	I/OV <sub>CC</sub> 1	CMOS Input/Output 1, Referenced to V <sub>CC</sub>

# Ultra-Low-Voltage Level Translators

## Pin Descriptions (continued)

### MAX13001E/MAX13004E

PIN		NAME	FUNCTION
TSSOP	UCSP		
1	B1	OV <sub>L</sub> 1	CMOS Output 1, Referenced to V <sub>L</sub>
2	B2	OV <sub>L</sub> 2	CMOS Output 2, Referenced to V <sub>L</sub>
3	A1	OV <sub>L</sub> 3	CMOS Output 3, Referenced to V <sub>L</sub>
4	A2	V <sub>L</sub>	Logic Input Voltage, $+0.9V \leq V_L \leq V_{CC}$ . Bypass V <sub>L</sub> to GND with a 0.1μF capacitor.
5	A3	EN	Enable Input. When EN is pulled low, OV <sub>CC</sub> 1 to OV <sub>CC</sub> 6 and IV <sub>L</sub> 1 to IV <sub>L</sub> 6 are tri-stated. Drive EN high (V <sub>L</sub> ) for normal operation.
6	A4	OV <sub>L</sub> 4	CMOS Output 4, Referenced to V <sub>L</sub>
7	B3	OV <sub>L</sub> 5	CMOS Output 5, Referenced to V <sub>L</sub>
8	B4	OV <sub>L</sub> 6	CMOS Output 6, Referenced to V <sub>L</sub>
9	C4	IV <sub>CC</sub> 6	Open-Drain-Compatible Input 6, Reference to V <sub>CC</sub>
10	C3	IV <sub>CC</sub> 5	Open-Drain-Compatible Input 5, Referenced to V <sub>CC</sub>
11	D4	IV <sub>CC</sub> 4	Open-Drain-Compatible Input 4, Referenced to V <sub>CC</sub>
12	D3	GND	Ground
13	D2	V <sub>CC</sub>	V <sub>CC</sub> Input Voltage, $+1.5V \leq V_{CC} \leq 3.6V$ . Bypass V <sub>CC</sub> to GND with a 0.1μF capacitor. For full ESD protection, use a 1μF bypass capacitor on V <sub>CC</sub> .
14	D1	IV <sub>CC</sub> 3	Open-Drain-Compatible Input 3, Referenced to V <sub>CC</sub>
15	C2	IV <sub>CC</sub> 2	Open-Drain-Compatible Input 2, Referenced to V <sub>CC</sub>
16	C1	IV <sub>CC</sub> 1	Open-Drain-Compatible Input 1, Referenced to V <sub>CC</sub>

# Ultra-Low-Voltage Level Translators

## Pin Descriptions (continued)

**MAX13000E-MAX13005E**

### MAX13002E/MAX13005E

PIN		NAME	FUNCTION
TSSOP	UCSP		
1	B1	IV <sub>L</sub> 1	Open-Drain-Compatible Input 1, Referenced to V <sub>L</sub>
2	B2	IV <sub>L</sub> 2	Open-Drain-Compatible Input 2, Referenced to V <sub>L</sub>
3	A1	IV <sub>L</sub> 3	Open-Drain-Compatible Input 3, Referenced to V <sub>L</sub>
4	A2	V <sub>L</sub>	Logic Input Voltage, $+0.9V \leq V_L \leq V_{CC}$ . Bypass V <sub>L</sub> to GND with a 0.1μF capacitor.
5	A3	EN	Enable Input. When EN is pulled low, OV <sub>CC</sub> 1 to OV <sub>CC</sub> 6 and IV <sub>L</sub> 1 to IV <sub>L</sub> 6 are tri-stated. Drive EN high (V <sub>L</sub> ) for normal operation.
6	A4	IV <sub>L</sub> 4	Open-Drain-Compatible Input 4, Referenced to V <sub>L</sub>
7	B3	IV <sub>L</sub> 5	Open-Drain-Compatible Input 5, Referenced to V <sub>L</sub>
8	B4	IV <sub>L</sub> 6	Open-Drain-Compatible Input 6, Referenced to V <sub>L</sub>
9	C4	OV <sub>CC</sub> 6	CMOS Output 6, Referenced to V <sub>CC</sub>
10	C3	OV <sub>CC</sub> 5	CMOS Output 5, Referenced to V <sub>CC</sub>
11	D4	OV <sub>CC</sub> 4	CMOS Output 4, Referenced to V <sub>CC</sub>
12	D3	GND	Ground
13	D2	V <sub>CC</sub>	V <sub>CC</sub> Input Voltage, $+1.5V \leq V_{CC} \leq 3.6V$ . Bypass V <sub>CC</sub> to GND with a 0.1μF capacitor. For full ESD protection, use a 1μF bypass capacitor on V <sub>CC</sub> .
14	D1	OV <sub>CC</sub> 3	CMOS Output 3, Referenced to V <sub>CC</sub>
15	C2	OV <sub>CC</sub> 2	CMOS Output 2, Referenced to V <sub>CC</sub>
16	C1	OV <sub>CC</sub> 1	CMOS Output 1, Referenced to V <sub>CC</sub>

# Ultra-Low-Voltage Level Translators

## Test Circuits/Timing Diagrams

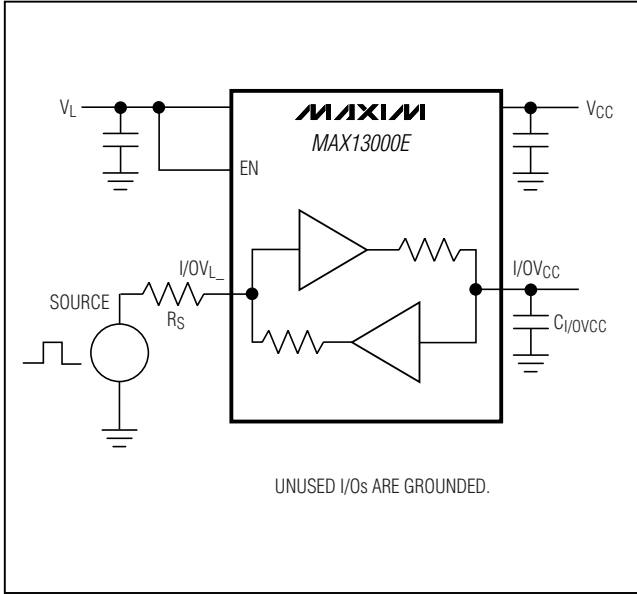

Figure 1a. Driving I/OVL

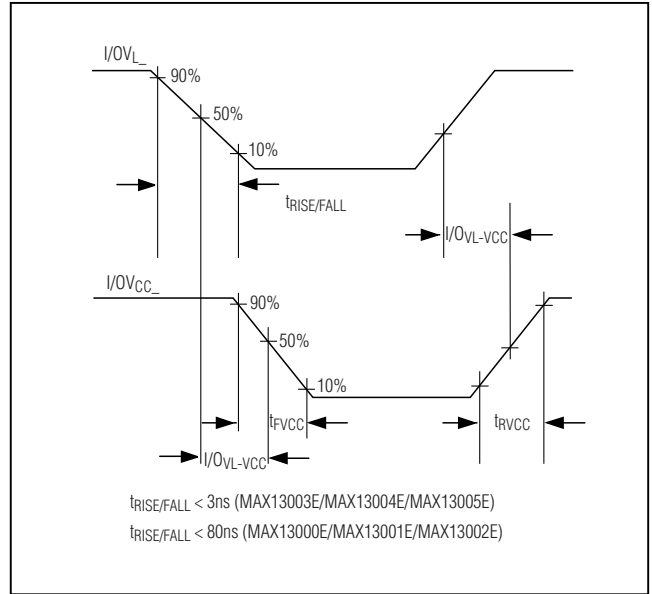

Figure 1b. Timing for Driving I/OVL

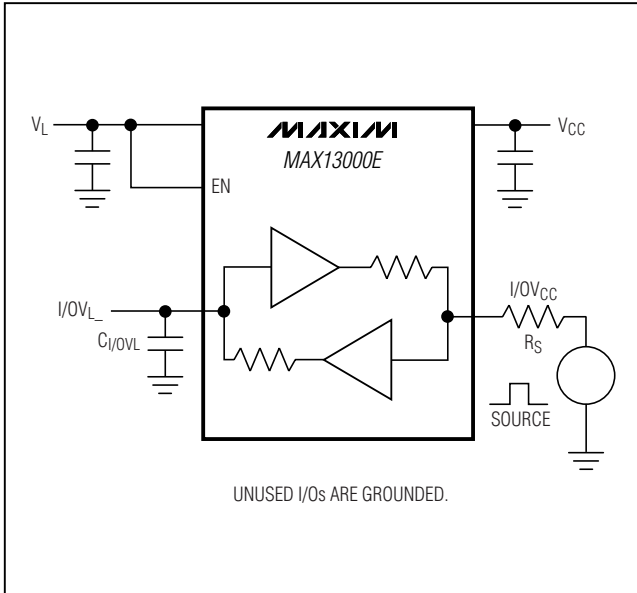

Figure 2a. Driving I/OVCC

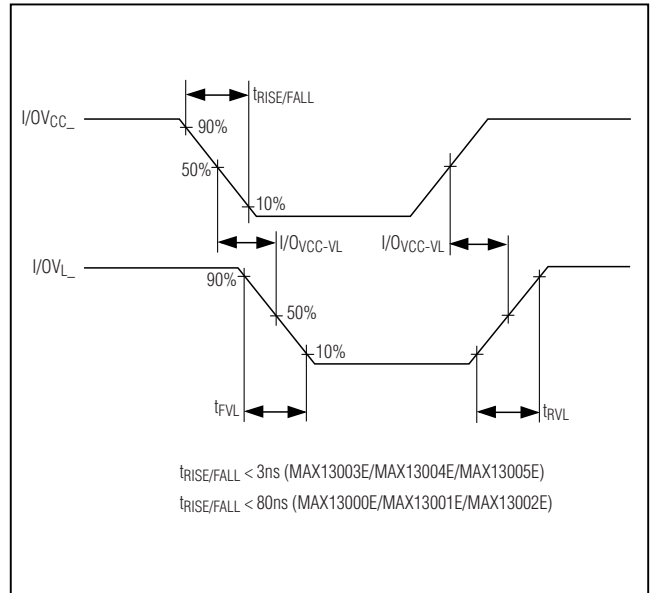
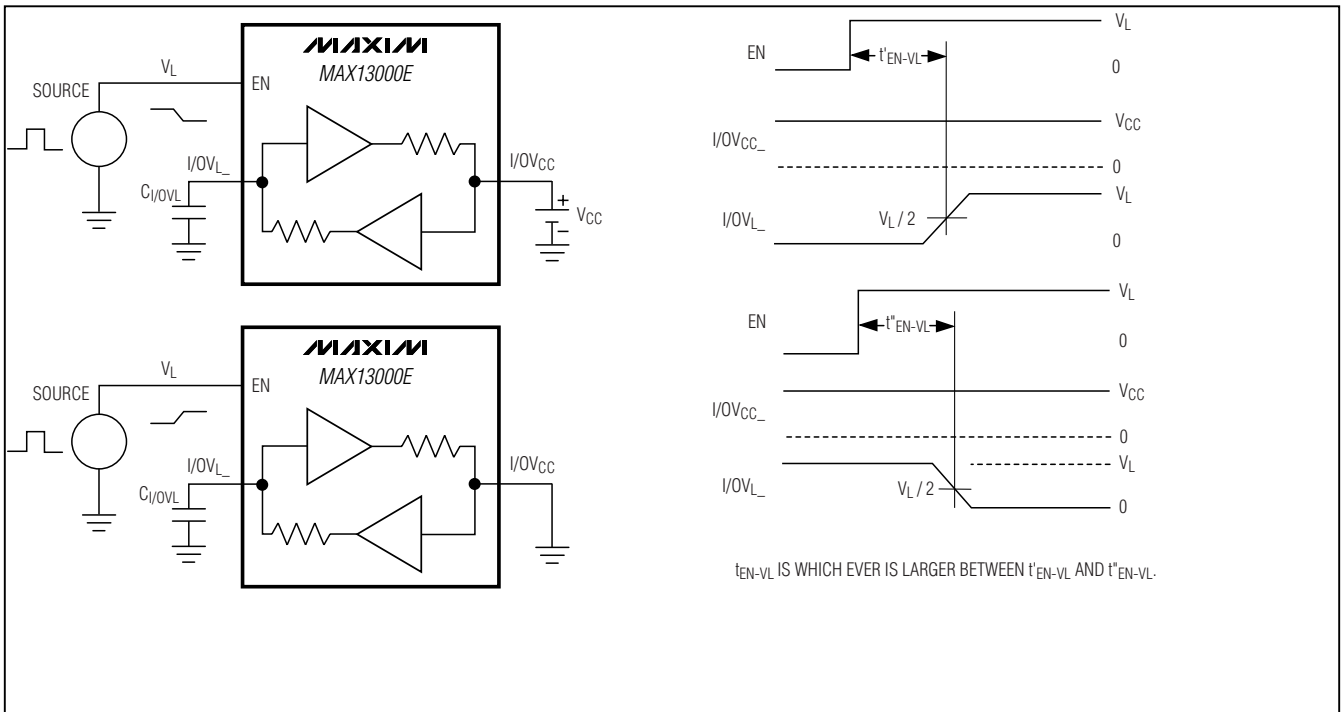
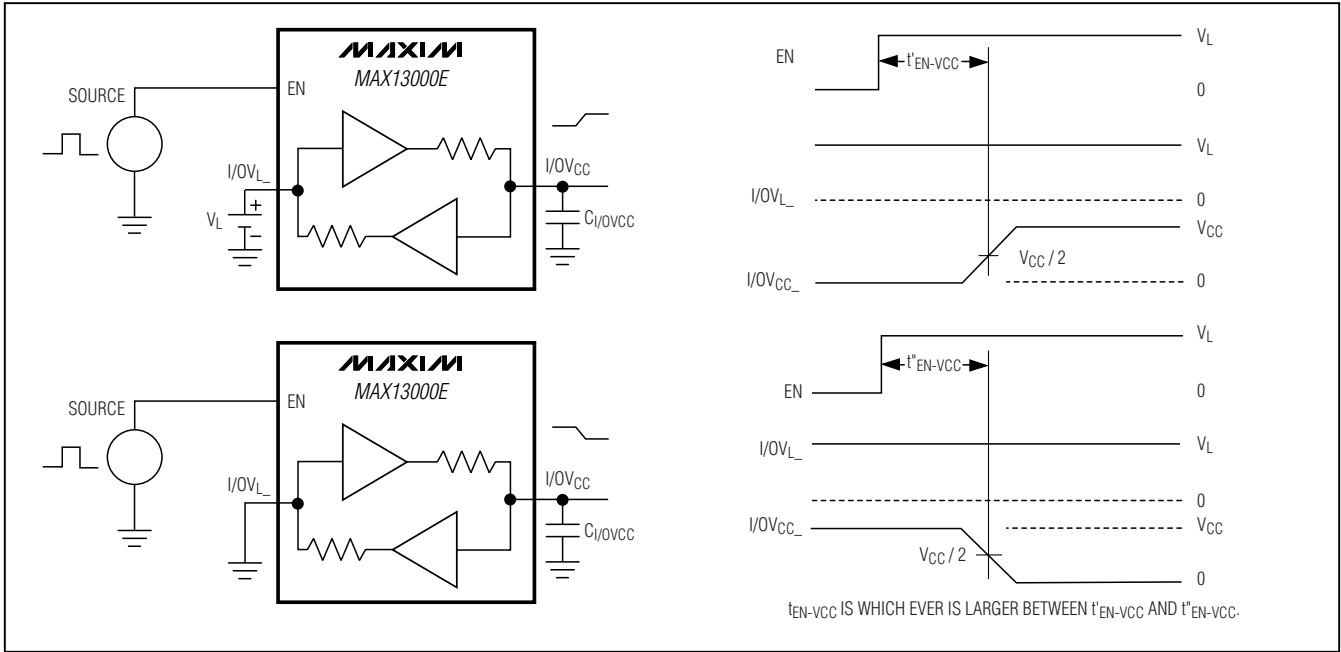

Figure 2b. Timing for Driving I/OVCC

# Ultra-Low-Voltage Level Translators

## Test Circuits/Timing Diagrams (continued)

MAX13000E-MAX13005E



# Ultra-Low-Voltage Level Translators

## Detailed Description

The MAX13000E–MAX13005E logic-level translators provide the level shifting necessary to allow data transfer in multivoltage systems. Externally applied voltages,  $V_{CC}$  and  $V_L$ , set the logic levels on each side of the device. Logic signals present on the  $V_L$  side of the device appear as higher voltage logic signals on the  $V_{CC}$  side of the device, and vice-versa.

The MAX13000E/MAX13003E are bidirectional level translators allowing data translation in either direction ( $V_L \leftrightarrow V_{CC}$ ) on any single data line without the use of a DIRECTION input. The MAX13001E/MAX13002E/MAX13004E/MAX13005E unidirectional level translators level shift data in one direction ( $V_L \rightarrow V_{CC}$  or  $V_{CC} \rightarrow V_L$ ) on any single data line. The MAX13001E/MAX13002E/MAX13004E/MAX13005E unidirectional translators' inputs have the capability to interface with both CMOS and open-drain (OD) outputs. For more information, see the *Ordering Information* section and the *Input Driver Requirements* section.

The MAX13000E–MAX13005E accept  $V_L$  from +0.9V to +3.6V. All devices have  $V_{CC}$  ranging from +1.5V to +3.6V, making them ideal for data transfer between low-voltage ASICs/PLDs and higher voltage systems.

The MAX13000E–MAX13005E feature low  $V_{CC}$  quiescent supply current of less than 4 $\mu$ A, and  $V_L$  quiescent supply current of less than 2 $\mu$ A when in shutdown. The MAX13000E–MAX13005E have  $\pm 15$ kV ESD protection on the  $V_{CC}$  side for greater protection in applications that route signals externally. The ESD protection is specified using the Human Body Model (HBM). The MAX13000E/MAX13001E/MAX13002E operate at a guaranteed 230kbps data rate. The MAX13003E/MAX13004E/MAX13005E operate at a guaranteed 20Mbps data rate when  $V_{CC} > +1.65$ V.

### Level Translation

For normal operation, ensure that  $+1.5\text{V} \leq V_{CC} \leq +3.6\text{V}$ , and  $+0.9\text{V} \leq V_L \leq V_{CC}$ . During power-up sequencing,  $V_L \geq V_{CC}$  does not damage the device whenever  $V_L$  is within the absolute maximum ratings (see the *Absolute Maximum Ratings* section). During power-supply sequencing, when  $V_{CC}$  is floating and  $V_L$  is powered up, 1mA of current can be sourced to each load on the  $V_L$  side, yet the device does not latch up.

The MAX13000E–MAX13005E are designed to have  $V_{CC} \geq V_L$  at all times; however, if  $V_{CC}$  is turned off, the part will not be damaged and will not latch up. To prevent excessive leakage currents in either the I/O or supply lines, the I/O on the  $V_L$  side must be left in the high state.

The maximum data rate for the MAX13000E–MAX13005E depends heavily on the load capacitance (see the *Typical Operating Characteristics*), output impedance of the driver, and the operational voltage range (see the *Timing Characteristics* table).

### Open-Drain Operation

The MAX13001E/MAX13002E/MAX13004E/MAX13005E have input stages specifically designed to accommodate external open-drain drivers. When using open-drain drivers, the MAX13001E/MAX13002E/MAX13004E/MAX13005E operate in a unidirectional-only mode, translating from the OD side to the CMOS side. For improved performance, the rise- and fall-time accelerators are present on both the CMOS and the OD side. See the *Input-Driver Requirement* section. Do not use pullup resistors greater than 15k $\Omega$  for proper operation, and smaller pullup resistance may be needed for higher speed operation.

### Input-Driver Requirements

The MAX13000E–MAX13005E feature four different architectures based on the speed of the part, as well as on whether the translator is a CMOS-to-CMOS translator, or whether it is an OD-to-CMOS translator.

#### 20Mbps CMOS-to-CMOS Bidirectional Translator (MAX13003E)

The MAX13003E architecture is based on a one-shot accelerator output stage (Figure 5). Accelerator output stages are always in tri-state, except when there is a transition on any of the translators on the input side, either I/O $V_L$  or I/O $V_{CC}$ . A short pulse is generated during which the one-shot output stage becomes active and charges/discharges the capacitances at the I/Os. Due to its bidirectional nature, the accelerator stages on both the I/O $V_{CC}$  and the I/O $V_L$  become active during an I/O transition from low to high or high to low. This can lead to some current feeding into the external source that is driving the translator. However, this behavior helps speed up the transition on the driven side.

The type of devices that drive the inputs of the MAX13003E is usually specified with an output drive-current capability ( $I_{OUT}$ ). When driving the inputs of the MAX13003E, the maximum achievable speed is constrained by the drive current of the external driver. To insure the maximum possible throughput of 20Mbps, the external driver should meet the following requirement:

$$I_{OUT} \geq 1.67 \times 10^8 \times V \times (C_{IN} + C_P)$$

# Ultra-Low-Voltage Level Translators

MAX13000E-MAX13005E

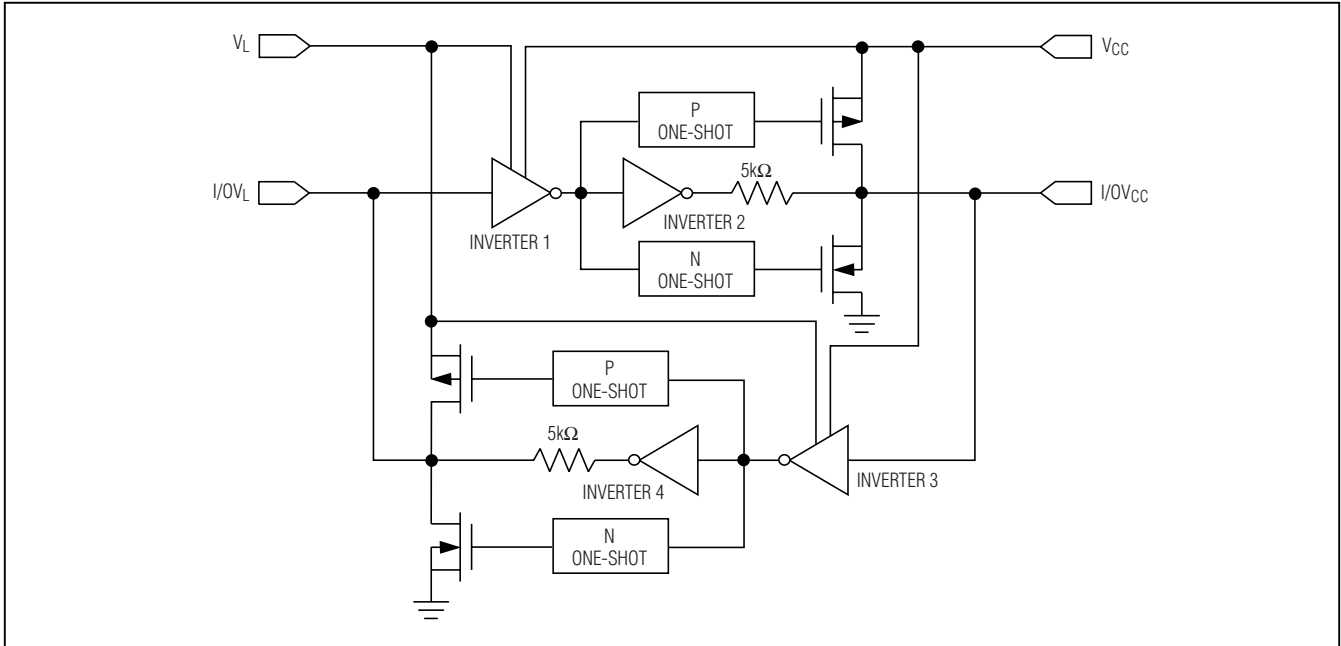

Figure 5. Architecture of 20Mbps, CMOS-to-CMOS Bidirectional Translators

where,  $C_p$  is the parasitic capacitance of the traces,  $V$  is the supply voltage of the driven side (i.e.,  $V_L$  or  $V_{CC}$ ), and  $C_{IN}$  is the input capacitance of the driven side ( $C_{IN} = 10\text{pF}$  for  $V_L$  side,  $C_{IN} = 20\text{pF}$  for  $V_{CC}$  side).

### 20Mbps OD-to-CMOS Unidirectional Translators (MAX13004E/MAX13005E)

The MAX13004E/MAX13005E architecture is virtually the same as that for the bidirectional CMOS-to-CMOS translators, the only difference being that the output inverter (inverter 4) at the driving side accommodates the driving capabilities of an open-drain output (Figure 6).

For proper operation, a pullup resistor needs to be connected from the open-drain output to the power supply of the driving side. Use pullup resistors no larger than  $15\text{k}\Omega$ .

### 230kbps CMOS-to-CMOS Bidirectional Translator (MAX13000E)

The architecture of the MAX13000E lacks the one-shot accelerator output stages since the transitions that this device handles are limited by its data rate, 230kbps (Figure 7).

For proper operation, the driver must meet the following conditions:  $1\text{k}\Omega$  maximum output impedance and  $1\text{mA}$  minimum output current.

### 230kbps OD-to-CMOS Unidirectional Translators (MAX13001E/MAX13002E)

The architecture of the MAX13001E/MAX13002E is similar to that of the 230kbps CMOS-to-CMOS part, with the difference that it accommodates the driving capability of an open-drain output on the driving side, and also that it has only a single one-shot output stage (Figure 8).

For proper operation, a pullup resistor needs to be connected from the open-drain output to the power supply of the driving side. Use pullup resistors no larger than  $15\text{k}\Omega$ .

Figure 9 shows a graph of the typical input current versus input voltage for all of the above configurations.

### Enable Output Mode (EN)

The MAX13000E-MAX13005E feature an enable (EN) input. Drive EN low to set the MAX13000E-MAX13005E I/Os in tri-state mode. Drive EN high ( $V_L$ ) for normal operation.

### $\pm 15\text{kV}$ ESD Protection

As with all Maxim devices, ESD-protection structures are incorporated on all pins to protect against electrostatic discharges encountered during handling and assembly. The I/OV<sub>CC</sub> lines have extra protection against static discharge. Maxim's engineers have developed state-of-the-art structures to protect these pins against ESD of  $\pm 15\text{kV}$  without damage. The ESD

# Ultra-Low-Voltage Level Translators

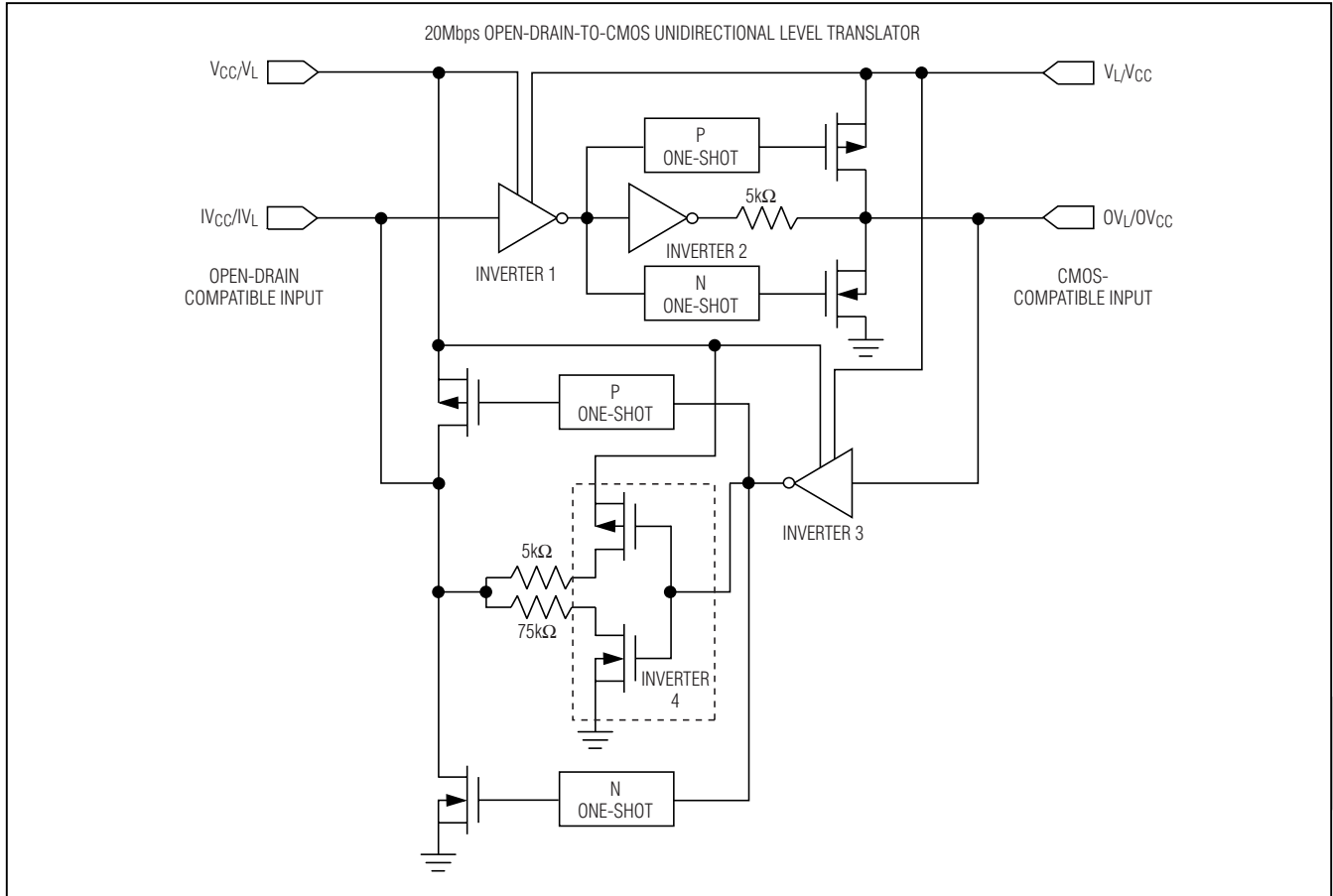

Figure 6. Architecture of 20Mbps, OD-to-CMOS Unidirectional Translators

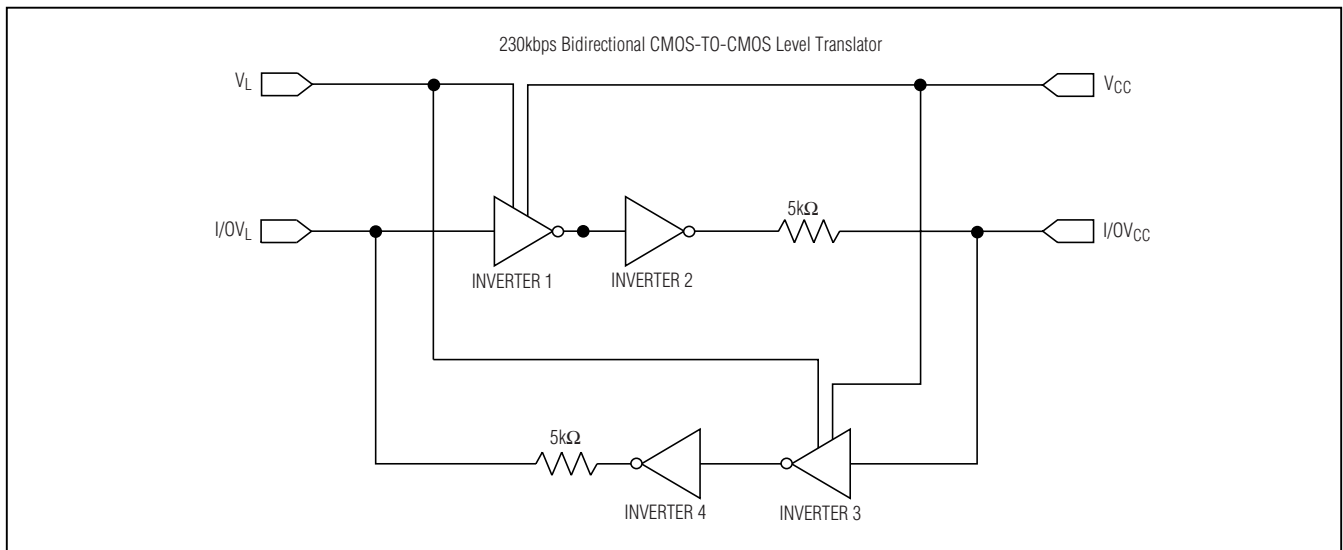

Figure 7. Architecture of 230kbps, CMOS-to-CMOS Bidirectional Translator

# Ultra-Low-Voltage Level Translators

MAX13000E-MAX13005E

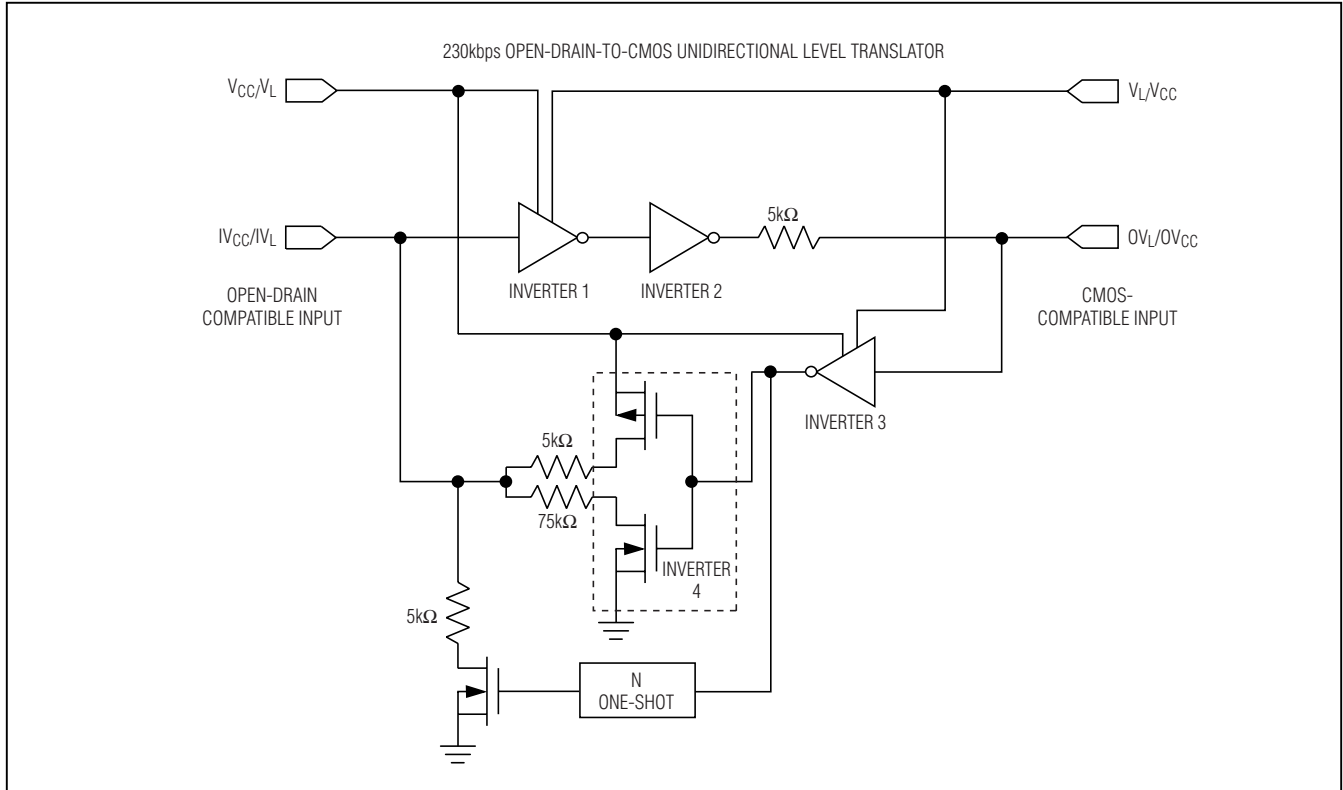

Figure 8. Architecture of 230kbps, OD-to-CMOS Unidirectional Translator

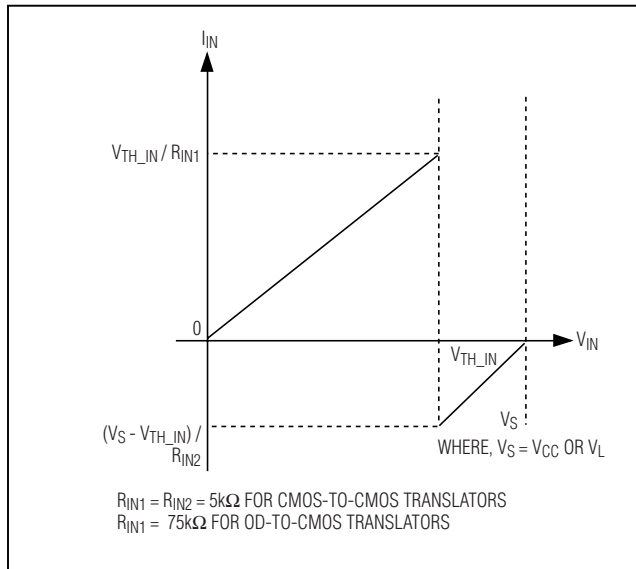

Figure 9. Typical  $I_{IN}$  vs.  $V_{IN}$

structures withstand high ESD in all states: normal operation, tri-state output mode, and power-down. After an ESD event, Maxim's E-versions keep working without latchup, whereas competing products can latch and must be powered-down to remove latchup.

ESD protection can be tested in various ways. The I/OV<sub>CC</sub> lines of the MAX13000E-MAX13005E are characterized for protection to  $\pm 15kV$  using the Human Body Model.

### ESD Test Conditions

ESD performance depends on a variety of conditions. Contact Maxim for a reliability report that documents test setup, test methodology, and test results.

### Human Body Model

Figure 10 shows the Human Body Model and Figure 11 shows the current waveform it generates when discharged into a low impedance. This model consists of a 100pF capacitor charged to the ESD voltage of interest, which is then discharged into the test device through a 1.5k $\Omega$  resistor.

# Ultra-Low-Voltage Level Translators

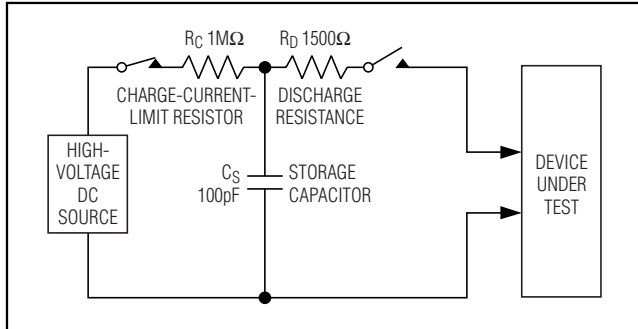

Figure 10. Human Body ESD Test Model

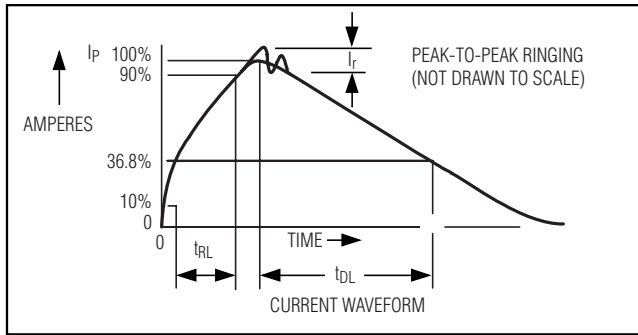

Figure 11. Human Body Current Waveform

## IEC 61000-4-2 Standard ESD Protection

The IEC 61000-4-2 standard (Figure 12) specifies ESD tolerance for electronic systems. The IEC61000-4-2 model specifies a 150pF capacitor that is discharged into the device through a 330Ω resistor. The MAX13000E-MAX13005E's I/O on the VCC side are rated for IEC 61000-4-2 standard, (8kV Contact Discharge and ±10kV Air-Gap Discharge).

The IEC 61000-4-2 model discharges higher peak current and more energy than the HBM due to the lower series resistance and larger capacitor.

## Applications Information

### Power-Supply Decoupling

To reduce ripple and the chance of transmitting incorrect data, bypass VL and VCC to ground with a 0.1μF capacitor. To ensure full ±15kV ESD protection, bypass VCC to ground with a 1μF capacitor. Place all capacitors as close to the power-supply inputs as possible.

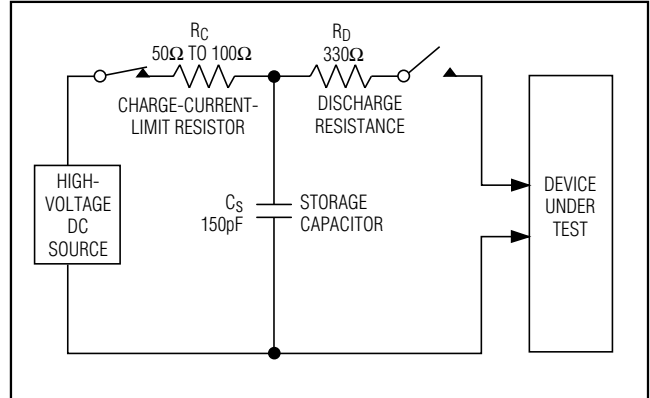

Figure 12. IEC 61000-4-2 Contact Discharge Test Model

### UCSP Package Considerations

For general UCSP package information and PC layout considerations, please refer to Maxim application note: Wafer-Level Chip-Scale Package.

### UCSP Reliability

The chip-scale package (UCSP) represents a unique packaging form factor that may not perform equally to a packaged product through traditional mechanical reliability tests. UCSP reliability is integrally linked to the user's assembly methods, circuit board material, and usage environment. The user should closely review these areas when considering use of a UCSP package. Performance through Operating Life Test and Moisture Resistance remains uncompromised as it is primarily determined by the wafer-fabrication process.

Mechanical stress performance is a greater consideration for a UCSP package. UCSPs are attached through direct solder contact to the user's PC board, foregoing the inherent stress relief of a packaged product lead frame. Solder joint contact integrity must be considered. Information on Maxim's qualification plan, test data, and recommendations are detailed in the UCSP application note, which can be found on Maxim's website at [www.maxim-ic.com](http://www.maxim-ic.com).

# Ultra-Low-Voltage Level Translators

## Functional Diagram

MAX13000E-MAX13005E

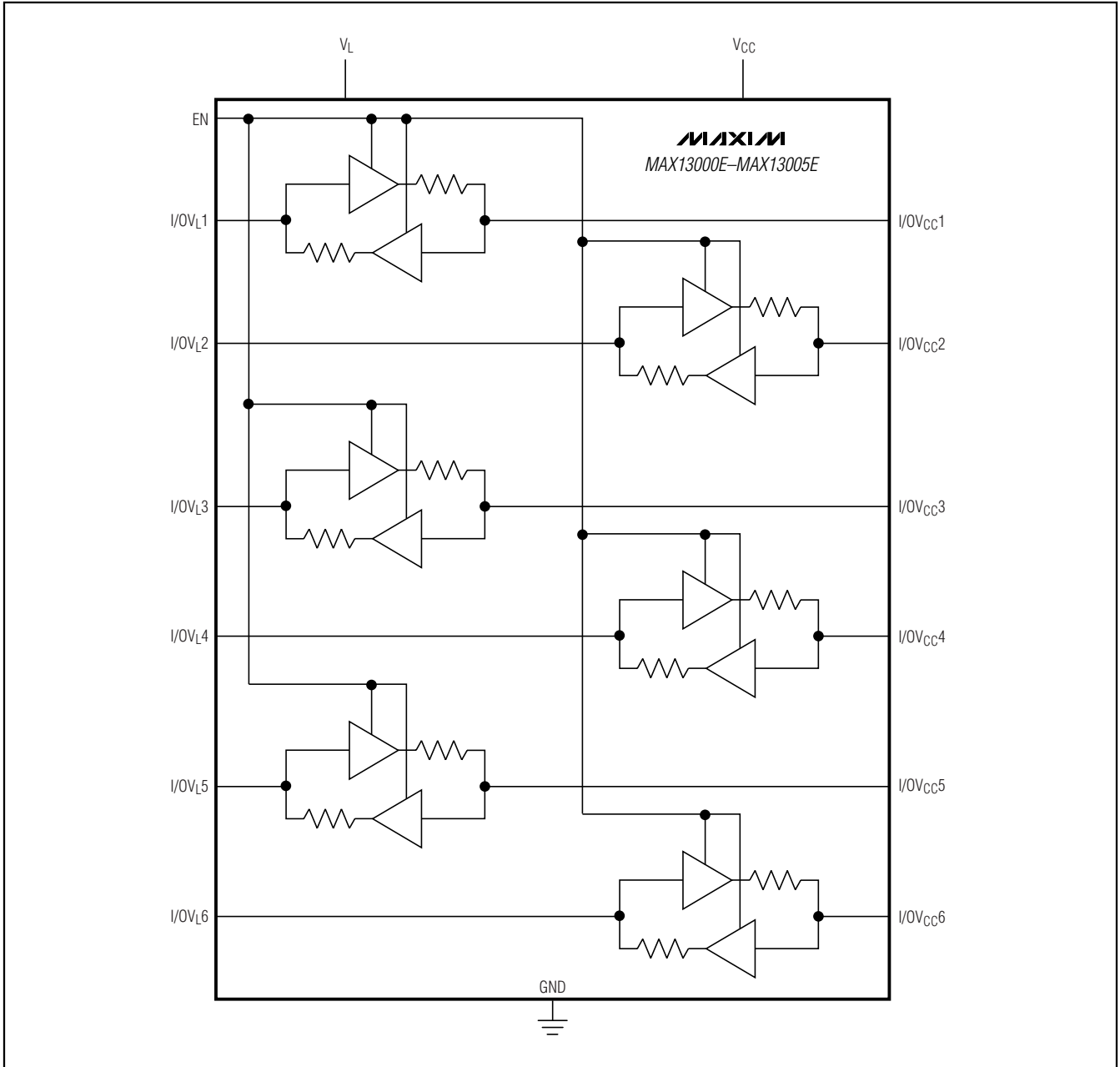

# Ultra-Low-Voltage Level Translators

## Typical Operating Circuits

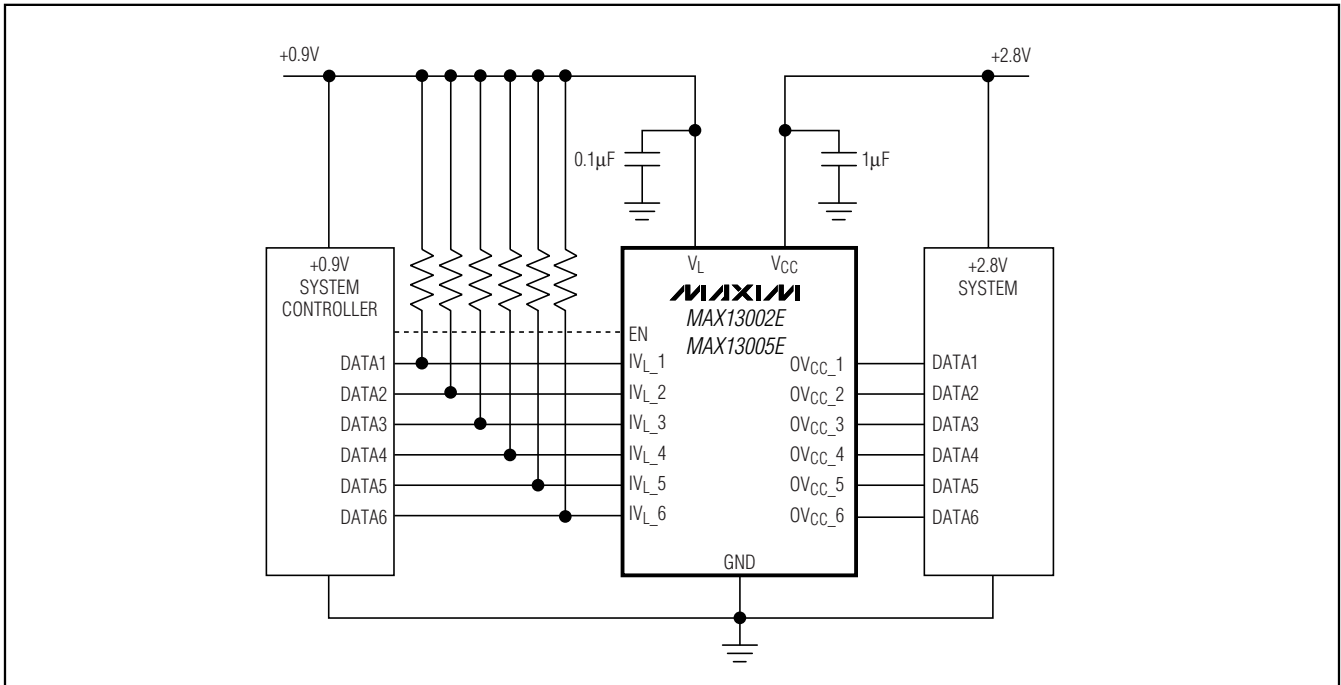
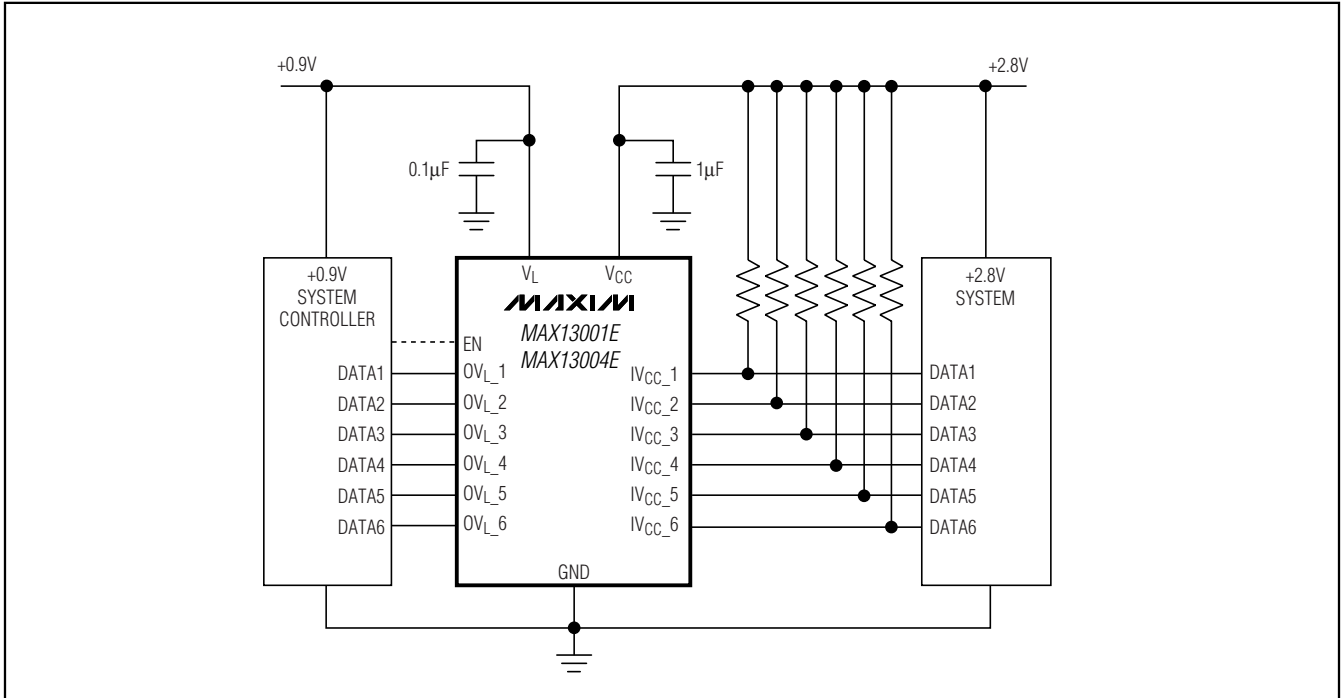

# Ultra-Low-Voltage Level Translators

## Typical Operating Circuits (continued)

**MAX13000E-MAX13005E**

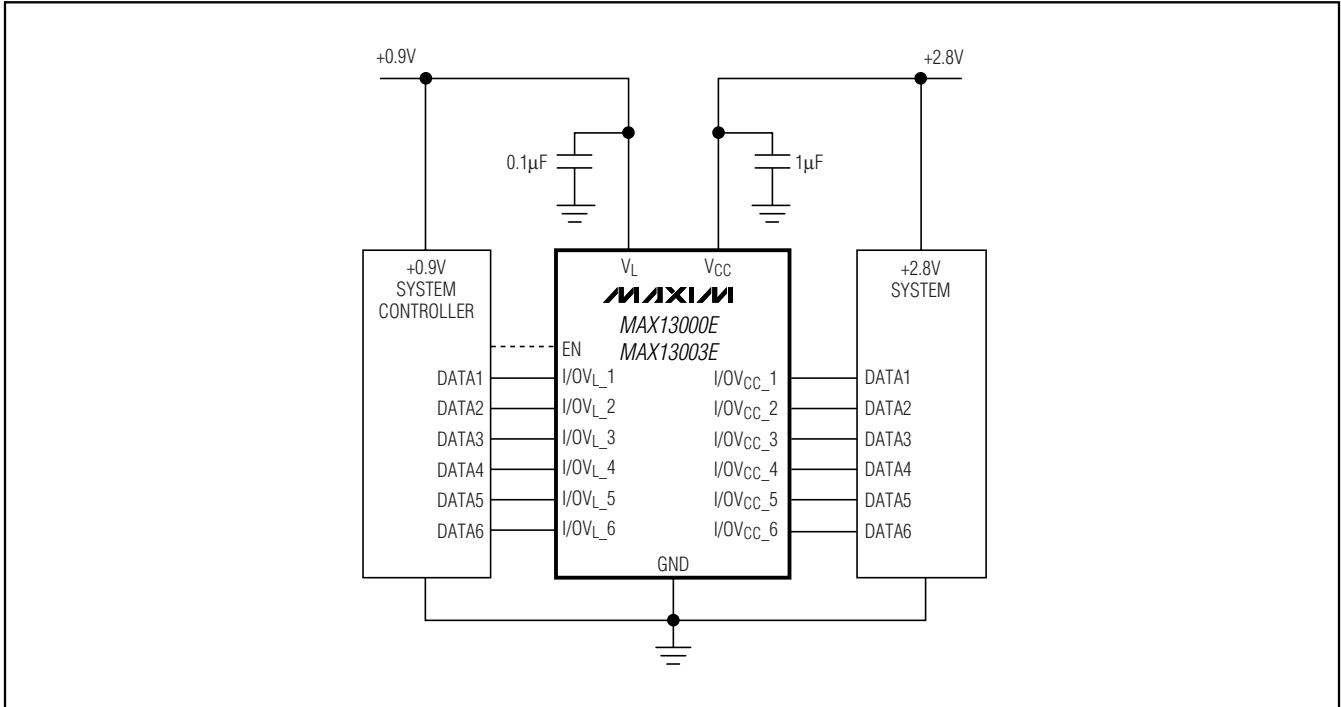

## Selector Guide

PART	DATA RATE (bps)	NUMBER OF BIDIRECTIONAL TRANSLATORS	NUMBER OF $V_L \rightarrow V_{CC}$ TRANSLATORS	NUMBER OF $V_{CC} \rightarrow V_L$ TRANSLATORS	TRANSLATOR CONFIGURATION
MAX13000E	230k	6	—	—	CMOS-to-CMOS
MAX13001E	230k	—	—	6	OD-to-CMOS
MAX13002E	230k	—	6	—	OD-to-CMOS
MAX13003E	20M	6	—	—	CMOS-to-CMOS
MAX13004E	20M	—	—	6	OD-to-CMOS
MAX13005E	20M	—	6	—	OD-to-CMOS

# Ultra-Low-Voltage Level Translators

## Pin Configurations (continued)

BOTTOM VIEW

MAX13001E/MAX13004E

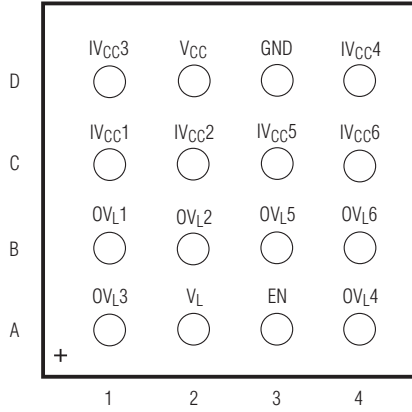

4 X 4 UCSP

MAX13002E/MAX13005E

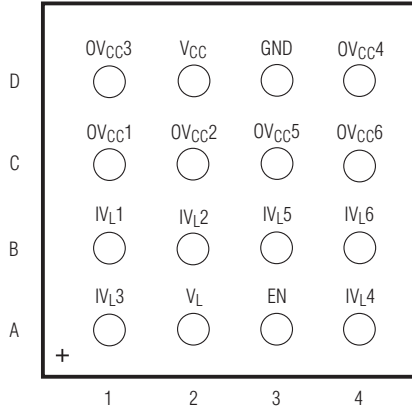

4 X 4 UCSP

TOP VIEW

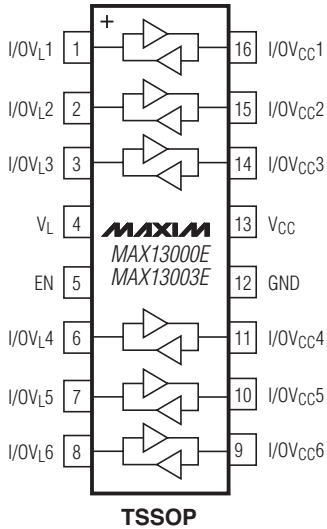

TSSOP

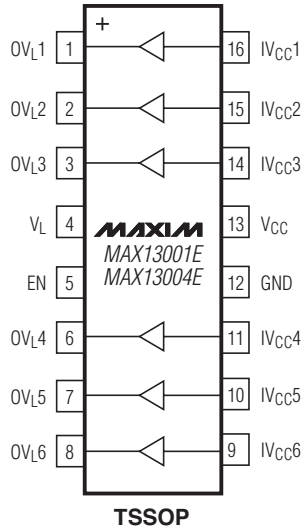

TSSOP

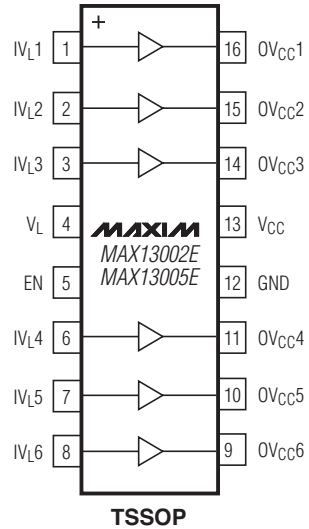

TSSOP

# Ultra-Low-Voltage Level Translators

## Ordering Information (continued)

PART	TEMP RANGE	PIN-PACKAGE
MAX13000EEBE+T*	-40°C to +85°C	16 UCSP (4mm × 4mm)
<b>MAX13001EEUE+</b>	-40°C to +85°C	16 TSSOP
MAX13001EEBE+T*	-40°C to +85°C	16 UCSP (4mm × 4mm)
<b>MAX13002EEUE+</b>	-40°C to +85°C	16 TSSOP
MAX13002EEBE+T*	-40°C to +85°C	16 UCSP (4mm × 4mm)
<b>MAX13003EEUE+</b>	-40°C to +85°C	16 TSSOP
MAX13003EEBE+T*	-40°C to +85°C	16 UCSP (4mm × 4mm)
<b>MAX13004EEUE+</b>	-40°C to +85°C	16 TSSOP
MAX13004EEBE+T*	-40°C to +85°C	16 UCSP (4mm × 4mm)
<b>MAX13005EEUE+</b>	-40°C to +85°C	16 TSSOP
MAX13005EEBE+T*	-40°C to +85°C	16 UCSP (4mm × 4mm)

\*Future Product—contact factory for availability.

+Denotes a lead(Pb)-free/RoHS-compliant package.

T =Tape and reel.

## Chip Information

PROCESS: BICMOS

**MAX13000E-MAX13005E**

# Ultra-Low-Voltage Level Translators

## Package Information

For the latest package outline information and land patterns (footprints), go to [www.maxim-ic.com/packages](http://www.maxim-ic.com/packages). Note that a "+", "#", or "-" in the package code indicates RoHS status only. Package drawings may show a different suffix character, but the drawing pertains to the package regardless of RoHS status.

PACKAGE TYPE	PACKAGE CODE	OUTLINE NO.	LAND PATTERN NO.
16 TSSOP	U16+2	<a href="#">21-0066</a>	<a href="#">90-0117</a>
16 UCSP	B16+1	<a href="#">21-0101</a>	Refer to <a href="#">Application Note 1891</a>

# Ultra-Low-Voltage Level Translators

## Revision History

REVISION NUMBER	REVISION DATE	DESCRIPTION	PAGES CHANGED
0	6/05	Initial release	—
1	5/11	Added lead-free information to the <i>Ordering Information</i>	1, 23

**MAX13000E-MAX13005E**

Maxim cannot assume responsibility for use of any circuitry other than circuitry entirely embodied in a Maxim product. No circuit patent licenses are implied. Maxim reserves the right to change the circuitry and specifications without notice at any time.

**Maxim Integrated Products, 120 San Gabriel Drive, Sunnyvale, CA 94086 408-737-7600** \_\_\_\_\_ 25

## Looking for pricing, stock, or lifecycle information?

Click below to explore more details on WIN SOURCE:

 [View MAX13003EEUE+ on WIN SOURCE](#)

 [Maxim Integrated](#) Information

## Optimize Your Supply Chain with WIN SOURCE Solutions

-  Global Sourcing Solution
-  Obsolete Management
-  Cost Control Management
-  Shortage Management
-  Alternative Solution
-  Excess Inventory Management