



**THE DATASHEET OF
MAX1282BEUE+T**



300ksps/400ksps, Single-Supply, 4-Channel, Serial 12-Bit ADCs with Internal Reference

General Description

The MAX1282/MAX1283 12-bit analog-to-digital converters (ADCs) combine a 4-channel analog-input multiplexer, high-bandwidth track/hold (T/H), and serial interface with high conversion speed and low power consumption. The MAX1282 operates from a single +4.5V to +5.5V supply; the MAX1283 operates from a single +2.7V to +3.6V supply. Both devices' analog inputs are software configurable for unipolar/bipolar and single-ended/pseudo-differential operation.

The 4-wire serial interface connects directly to SPI™/QSPI™/MICROWIRE™ devices without external logic. A serial strobe output allows direct connection to TMS320-family digital signal processors. The MAX1282/MAX1283 use an external serial-interface clock to perform successive-approximation analog-to-digital conversions. The devices feature an internal +2.5V reference and a reference-buffer amplifier with a $\pm 1.5\%$ voltage-adjustment range. An external reference with a 1V to V_{DD} range may also be used.

The MAX1282/MAX1283 provide a hardwired $\overline{\text{SHDN}}$ pin and four software-selectable power modes (normal operation, reduced power (REDP), fast power-down (FASTPD), and full power-down (FULLPD)). These devices can be programmed to automatically shut down at the end of a conversion or to operate with reduced power. When using the power-down modes, accessing the serial interface automatically powers up the devices, and the quick turn-on time allows them to be shut down between all conversions.

The MAX1282/MAX1283 are available in 16-pin TSSOP packages.

Applications

- Portable Data Logging
- Data Acquisition
- Medical Instruments
- Battery-Powered Instruments
- Pen Digitizers
- Process Control

Typical Operating Circuit appears at end of data sheet.

SPI and QSPI are trademarks of Motorola, Inc.

MICROWIRE is a trademark of National Semiconductor Corp.

Features

- ◆ 4-Channel Single-Ended or 2-Channel Pseudo-Differential Inputs
- ◆ Internal Multiplexer and Track/Hold
- ◆ Single-Supply Operation
 - +4.5V to +5.5V (MAX1282)
 - +2.7V to +3.6V (MAX1283)
- ◆ Internal +2.5V Reference
- ◆ 400kHz Sampling Rate (MAX1282)
- ◆ Low Power: 2.5mA (400ksps)
 - 1.3mA (REDP)
 - 0.9mA (FASTPD)
 - 2 μ A (FULLPD)
- ◆ SPI/QSPI/MICROWIRE/TMS320-Compatible 4-Wire Serial Interface
- ◆ Software-Configurable Unipolar or Bipolar Inputs
- ◆ 16-Pin TSSOP Package

Ordering Information

PART	TEMP. RANGE	PIN-PACKAGE	INL (LSB)
MAX1282BCUE	0°C to +70°C	16 TSSOP	± 1
MAX1282BEUE	-40°C to +85°C	16 TSSOP	± 1
MAX1283BCUE	0°C to +70°C	16 TSSOP	± 1
MAX1283BEUE	-40°C to +85°C	16 TSSOP	± 1

Pin Configuration

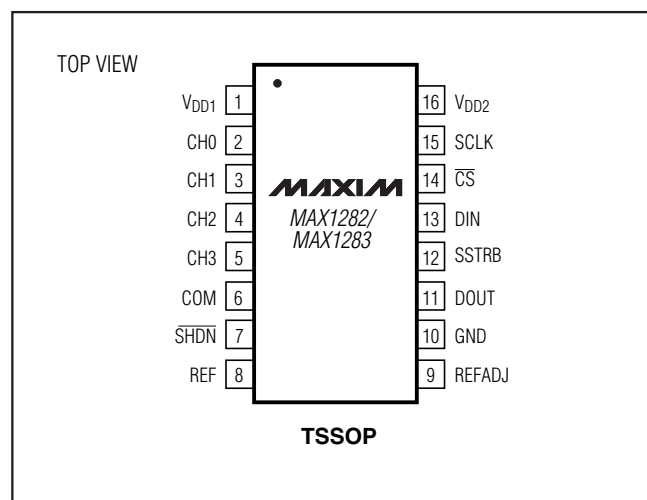

300ksps/400ksps, Single-Supply, 4-Channel, Serial 12-Bit ADCs with Internal Reference

ABSOLUTE MAXIMUM RATINGS

V _{DD_} to GND	-0.3V to +6V
V _{DD1} to V _{DD2}	-0.3V to +0.3V
CH0-CH3, COM to GND	-0.3V to (V _{DD_} +0.3V)
REF, REFADJ to GND	-0.3V to V _{DD_} +0.3V)
Digital Inputs to GND	-0.3V to +6V
Digital Outputs to GND	-0.3V to (V _{DD_} +0.3V)
Digital Output Sink Current	25mA

Continuous Power Dissipation (T _A = +70°C)	
16-Pin TSSOP (derate 6.7mW/°C above +70°C)	535mW
Operating Temperature Ranges	
MAX1282BCUE/MAX1283BCUE	0°C to +70°C
MAX1282BEUE/MAX1283BEUE	-40°C to +85°C
Storage Temperature Range	-60°C to +150°C
Lead Temperature (soldering, 10s)	+300°C

Stresses beyond those listed under "Absolute Maximum Ratings" may cause permanent damage to the device. These are stress ratings only, and functional operation of the device at these or any other conditions beyond those indicated in the operational sections of the specifications is not implied. Exposure to absolute maximum rating conditions for extended periods may affect device reliability.

ELECTRICAL CHARACTERISTICS—MAX1282

(V_{DD1} = V_{DD2} = +4.5V to +5.5V, COM = GND, f_{OSC} = 6.4MHz, 50% duty cycle, 16 clocks/conversion cycle (400ksps), external +2.5V at REF, REFADJ = V_{DD1}, T_A = T_{MIN} to T_{MAX}, unless otherwise noted. Typical values are at T_A = +25°C.)

PARAMETER	SYMBOL	CONDITIONS	MIN	TYP	MAX	UNITS
DC ACCURACY (Note 1)						
Resolution			12			Bits
Relative Accuracy (Note 2)	INL				±1.0	LSB
Differential Nonlinearity	DNL	No missing codes over temperature			±1.0	LSB
Offset Error					±6.0	LSB
Gain Error (Note 3)					±6.0	LSB
Gain-Error Temperature Coefficient				±1.6		ppm/°C
Channel-to-Channel Offset-Error Matching				±0.2		LSB
DYNAMIC SPECIFICATIONS (100kHz sine-wave input, 2.5Vp-p, 400ksps, 6.4MHz clock, bipolar input mode)						
Signal-to-Noise plus Distortion Ratio	SINAD			70		dB
Total Harmonic Distortion	THD	Up to the 5th harmonic		-81		dB
Spurious-Free Dynamic Range	SFDR			80		dB
Intermodulation Distortion	IMD	f _{IN1} = 99kHz, f _{IN2} = 102kHz		76		dB
Channel-to-Channel Crosstalk (Note 4)		200kHz, V _{IN} = 2.5Vp-p		-78		dB
Full-Power Bandwidth		-3dB point		6		MHz
Full-Linear Bandwidth		SINAD > 68dB		350		kHz
CONVERSION RATE						
Conversion Time (Note 5)	t _{CONV}		2.5			µs
Track/Hold Acquisition Time	t _{ACQ}				400	ns
Aperture Delay				10		ns
Aperture Jitter				<50		ps
Serial Clock Frequency	f _{SCLK}		0.5		6.4	MHz
Duty Cycle			40		60	%

300ksps/400ksps, Single-Supply, 4-Channel, Serial 12-Bit ADCs with Internal Reference

MAX1282/MAX1283

ELECTRICAL CHARACTERISTICS—MAX1282 (continued)

($V_{DD1} = V_{DD2} = +4.5V$ to $+5.5V$, $COM = GND$, $f_{OSC} = 6.4MHz$, 50% duty cycle, 16 clocks/conversion cycle (400ksps), external $+2.5V$ at REF, REFADJ = V_{DD1} , $T_A = T_{MIN}$ to T_{MAX} , unless otherwise noted. Typical values are at $T_A = +25^{\circ}C$.)

PARAMETER	SYMBOL	CONDITIONS	MIN	TYP	MAX	UNITS
ANALOG INPUTS (CH3–CH0, COM)						
Input Voltage Range, Single-Ended and Differential (Note 6)	$V_{CH_}$	Unipolar, $V_{COM} = 0$			V_{REF}	V
		Bipolar, V_{COM} or $V_{CH_} = V_{REF}/2$, referenced to COM or $CH_$			$\pm V_{REF}/2$	
Multiplexer Leakage Current		On/off leakage current, V_{COM} , $V_{CH_} = 0$ or V_{DD1}		± 0.001	± 1	μA
Input Capacitance				18		pF
INTERNAL REFERENCE						
REF Output Voltage	V_{REF}	$T_A = +25^{\circ}C$	2.480	2.500	2.520	V
REF Short-Circuit Current				15		mA
REF Output Temperature Coefficient	TC V_{REF}			± 15		ppm/ $^{\circ}C$
Load Regulation (Note 7)		0 to 1mA output load		0.05	2.0	mV/mA
Capacitive Bypass at REF			4.7		10	μF
Capacitive Bypass at REFADJ			0.01		10	μF
REFADJ Output Voltage				1.22		V
REFADJ Input Range		For small adjustments, from 1.22V		± 100		mV
REFADJ Buffer Disable Threshold		To power down the internal reference	1.4		$V_{DD1} - 1.0$	V
Buffer Voltage Gain				+2.05		V/V
EXTERNAL REFERENCE (reference buffer disabled, reference applied to REF)						
REF Input Voltage Range		(Note 8)	1.0		$V_{DD1} + 50mV$	V
REF Input Current		$V_{REF} = 2.500V$, $f_{SCLK} = f_{MAX}$		200	350	μA
		$V_{REF} = 2.500V$, $f_{SCLK} = 0$			320	
		In full power-down mode, $f_{SCLK} = 0$			5	
DIGITAL INPUTS (DIN, SCLK, CS, SHDN)						
Input High Voltage	V_{INH}		3.0			V
Input Low Voltage	V_{INL}				0.8	V
Input Hysteresis	V_{HYST}			0.2		V
Input Leakage	I_{IN}	$V_{IN} = 0$ or V_{DD2}			± 1	μA
Input Capacitance	C_{IN}			15		pF
DIGITAL OUTPUTS (DOUT, SSTRB)						
Output Voltage Low	V_{OL}	$I_{SINK} = 5mA$			0.4	V
Output Voltage High	V_{OH}	$I_{SOURCE} = 1mA$	4			V
Three-State Leakage Current	I_L	$\overline{CS} = V_{DD2}$			± 10	μA
Three-State Output Capacitance	C_{OUT}	$\overline{CS} = V_{DD2}$		15		pF

300ksps/400ksps, Single-Supply, 4-Channel, Serial 12-Bit ADCs with Internal Reference

ELECTRICAL CHARACTERISTICS—MAX1282 (continued)

($V_{DD1} = V_{DD2} = +4.5V$ to $+5.5V$, $COM = GND$, $f_{OSC} = 6.4MHz$, 50% duty cycle, 16 clocks/conversion cycle (400ksps), external $+2.5V$ at REF, $REFADJ = V_{DD1}$, $T_A = T_{MIN}$ to T_{MAX} , unless otherwise noted. Typical values are at $T_A = +25^{\circ}C$.)

PARAMETER	SYMBOL	CONDITIONS	MIN	TYP	MAX	UNITS
POWER SUPPLY						
Positive Supply Voltage (Note 9)	V_{DD1} , V_{DD2}		4.5		5.5	V
Supply Current	$I_{V_{DD1}+V_{DD2}}$	$V_{DD1} = V_{DD2} = 5.5V$	Normal operating mode (Note 10)	2.5	4.0	mA
			Reduced-power mode (Note 11)	1.3	2.0	
			Fast power-down mode (Note 11)	0.9	1.5	
			Full power-down mode (Note 11)	2.0	10	
Power-Supply Rejection	PSR	$V_{DD1} = V_{DD2} = 5V \pm 10\%$, midscale input		± 0.5	± 2.0	mV

ELECTRICAL CHARACTERISTICS—MAX1283

($V_{DD1} = V_{DD2} = +2.7V$ to $+3.6V$, $COM = GND$, $f_{OSC} = 4.8MHz$, 50% duty cycle, 16 clocks/conversion cycle (300ksps), external $+2.5V$ at REF, $REFADJ = V_{DD1}$, $T_A = T_{MIN}$ to T_{MAX} , unless otherwise noted. Typical values are at $T_A = +25^{\circ}C$.)

PARAMETER	SYMBOL	CONDITIONS	MIN	TYP	MAX	UNITS
DC ACCURACY (Note 1)						
Resolution			12			Bits
Relative Accuracy (Note 2)	INL				± 1.0	LSB
Differential Nonlinearity	DNL	No missing codes over temperature			± 1.0	LSB
Offset Error					± 6.0	LSB
Gain Error (Note 3)					± 6.0	LSB
Gain-Error Temperature Coefficient				± 1.6		ppm/ $^{\circ}C$
Channel-to-Channel Offset-Error Matching				± 0.2		LSB
DYNAMIC SPECIFICATIONS (100kHz sine-wave input, 2.5Vp-p, 400ksps, 6.4MHz clock, bipolar input mode)						
Signal-to-Noise plus Distortion Ratio	SINAD			70		dB
Total Harmonic Distortion	THD	Up to the 5th harmonic		-70		dB
Spurious-Free Dynamic Range	SFDR			72		dB
Intermodulation Distortion	IMD	$f_{IN1} = 73kHz$, $f_{IN2} = 77kHz$		76		dB
Channel-to-Channel Crosstalk (Note 4)		$f = 150kHz$, $V_{IN} = 2.5Vp-p$		-78		dB
Full-Power Bandwidth		-3dB point		3		MHz
Full-Linear Bandwidth		SINAD > 68dB		250		kHz

300ksps/400ksps, Single-Supply, 4-Channel, Serial 12-Bit ADCs with Internal Reference

MAX1282/MAX1283

ELECTRICAL CHARACTERISTICS—MAX1283 (continued)

($V_{DD1} = V_{DD2} = +2.7V$ to $+3.6V$, $COM = GND$, $f_{OSC} = 4.8MHz$, 50% duty cycle, 16 clocks/conversion cycle (300ksps), external $+2.5V$ at REF, REFADJ = V_{DD1} , $T_A = T_{MIN}$ to T_{MAX} , unless otherwise noted. Typical values are at $T_A = +25^{\circ}C$.)

PARAMETER	SYMBOL	CONDITIONS	MIN	TYP	MAX	UNITS
CONVERSION RATE						
Conversion Time (Note 5)	t_{CONV}	Normal operating mode	3.3			μs
Track/Hold Acquisition Time	t_{ACQ}	Normal operating mode			625	ns
Aperture Delay				10		ns
Aperture Jitter				<50		ps
Serial Clock Frequency	f_{SCLK}	Normal operating mode	0.5		4.8	MHz
Duty Cycle			40		60	%
ANALOG INPUTS (CH3–CH0, COM)						
Input Voltage Range, Single Ended and Differential (Note 6)	$V_{CH_}$	Unipolar, $V_{COM} = 0$			V_{REF}	V
		Bipolar, V_{COM} or $V_{CH_} = V_{REF}/2$, referenced to COM or $CH_$			$\pm V_{REF}/2$	
Multiplexer Leakage Current		On/off leakage current, $V_{CH_} = 0$ or V_{DD1}		± 0.001	± 1	μA
Input Capacitance				18		pF
INTERNAL REFERENCE						
REF Output Voltage	V_{REF}	$T_A = +25^{\circ}C$	2.480	2.500	2.520	V
REF Short-Circuit Current				15		mA
REF Output Temperature Coefficient	TC V_{REF}			± 15		ppm/ $^{\circ}C$
Load Regulation (Note 7)		0 to 0.75mA output load		0.1	2.0	mV/mA
Capacitive Bypass at REF			4.7		10	μF
Capacitive Bypass at REFADJ			0.01		10	μF
REFADJ Output Voltage				1.22		V
REFADJ Input Range		For small adjustments, from 1.22V		± 100		mV
REFADJ Buffer Disable Threshold		To power down the internal reference	1.4		$V_{DD1} - 1.0$	V
Buffer Voltage Gain				2.05		V/V
EXTERNAL REFERENCE (reference buffer disabled, reference applied to REF)						
REF Input Voltage Range		(Note 8)	1.0		$V_{DD1} + 50mV$	V
REF Input Current		$V_{REF} = 2.500V$, $f_{SCLK} = f_{MAX}$		200	350	μA
		$V_{REF} = 2.500V$, $f_{SCLK} = 0$			320	
		In full power-down mode, $f_{SCLK} = 0$			5	
DIGITAL INPUTS (DIN, SCLK, \overline{CS}, SHDN)						
Input High Voltage	V_{INH}		2.0			V
Input Low Voltage	V_{INL}				0.8	V
Input Hysteresis	V_{HYST}			0.2		V
Input Leakage	I_{IN}	$V_{IN} = 0$ or V_{DD2}			± 1	μA
Input Capacitance	C_{IN}			15		pF

300ksps/400ksps, Single-Supply, 4-Channel, Serial 12-Bit ADCs with Internal Reference

ELECTRICAL CHARACTERISTICS—MAX1283 (continued)

($V_{DD1} = V_{DD2} = +2.7V$ to $+3.6V$, $COM = GND$, $f_{OSC} = 4.8MHz$, 50% duty cycle, 16 clocks/conversion cycle (300ksps), external $+2.5V$ at REF , $REFADJ = V_{DD1}$, $T_A = T_{MIN}$ to T_{MAX} , unless otherwise noted. Typical values are at $T_A = +25^{\circ}C$.)

PARAMETER	SYMBOL	CONDITIONS	MIN	TYP	MAX	UNITS
DIGITAL OUTPUTS (DOUT, SSTRB)						
Output Voltage Low	V_{OL}	$I_{SINK} = 5mA$			0.4	V
Output Voltage High	V_{OH}	$I_{SOURCE} = 0.5mA$	$V_{DD2} - 0.5V$			V
Three-State Leakage Current	I_L	$\overline{CS} = V_{DD2}$			± 10	μA
Three-State Output Capacitance	C_{OUT}	$\overline{CS} = V_{DD2}$		15		pF
POWER SUPPLY						
Positive Supply Voltage (Note 9)	V_{DD1} , V_{DD2}		2.7		3.6	V
Supply Current	$I_{VDD1} + I_{VDD2}$	$V_{DD1} = V_{DD2} = 3.6V$	Normal operating mode (Note 10)	2.5	3.5	mA
			Reduced-power mode (Note 11)	1.3	2.0	
			Fast power-down mode (Note 11)	0.9	1.5	
			Full power-down mode (Note 11)	2.0	10	μA
Power-Supply Rejection	PSR	$V_{DD1} = V_{DD2} = 2.7V$ to $3.6V$, midscale input		± 0.5	± 2.0	mV

TIMING CHARACTERISTICS—MAX1282

(Figures 1, 2, 5, 6; $V_{DD1} = V_{DD2} = +4.5V$ to $+5.5V$, $T_A = T_{MIN}$ to T_{MAX} , unless otherwise noted.)

PARAMETER	SYMBOL	CONDITIONS	MIN	TYP	MAX	UNITS
SCLK Period	t_{CP}		156			ns
SCLK Pulse Width High	t_{CH}		62			ns
SCLK Pulse Width Low	t_{CL}		62			ns
DIN to SCLK Setup	t_{DS}		35			ns
DIN to SCLK Hold	t_{DH}		0			ns
\overline{CS} Fall to SCLK Rise Setup	t_{CSS}		35			ns
SCLK Rise to \overline{CS} Rise Hold	t_{CSH}		0			ns
SCLK Rise to \overline{CS} Fall Ignore	t_{CSO}		35			ns
\overline{CS} Rise to SCLK Rise Ignore	t_{CS1}		35			ns
SCLK Rise to DOUT Hold	t_{DOH}	$C_{LOAD} = 20pF$	10	20		ns
SCLK Rise to SSTRB Hold	t_{STH}	$C_{LOAD} = 20pF$	10	20		ns
SCLK Rise to DOUT Valid	t_{DOV}	$C_{LOAD} = 20pF$			80	ns
SCLK Rise to SSTRB Valid	t_{STV}	$C_{LOAD} = 20pF$			80	ns
\overline{CS} Rise to DOUT Disable	t_{DOD}	$C_{LOAD} = 20pF$	10		65	ns
\overline{CS} Rise to SSTRB Disable	t_{STD}	$C_{LOAD} = 20pF$	10		65	ns
\overline{CS} Fall to DOUT Enable	t_{DOE}	$C_{LOAD} = 20pF$			65	ns
\overline{CS} Fall to SSTRB Enable	t_{STE}	$C_{LOAD} = 20pF$			65	ns
\overline{CS} Pulse Width High	t_{CSW}		100			ns

300ksps/400ksps, Single-Supply, 4-Channel, Serial 12-Bit ADCs with Internal Reference

MAX1282/MAX1283

TIMING CHARACTERISTICS—MAX1283

(Figures 1, 2, 5, 6; $V_{DD1} = V_{DD2} = +2.7V$ to $+3.6V$, $T_A = T_{MIN}$ to T_{MAX} , unless otherwise noted.)

PARAMETER	SYMBOL	CONDITIONS	MIN	TYP	MAX	UNITS
SCLK Period	t _{CP}		208			ns
SCLK Pulse Width High	t _{CH}		83			ns
SCLK Pulse Width Low	t _{CL}		83			ns
DIN to SCLK Setup	t _{DS}		45			ns
DIN to SCLK Hold	t _{DH}		0			ns
\overline{CS} Fall to SCLK Rise Setup	t _{CSS}		45			ns
SCLK Rise to \overline{CS} Rise Hold	t _{CSH}		0			ns
SCLK Rise to \overline{CS} Fall Ignore	t _{CSSO}		45			ns
\overline{CS} Rise to SCLK Rise Ignore	t _{CSS1}		45			ns
SCLK Rise to DOUT Hold	t _{DOH}	C _{LOAD} = 20pF	13	20		ns
SCLK Rise to SSTRB Hold	t _{STH}	C _{LOAD} = 20pF	13	20		ns
SCLK Rise to DOUT Valid	t _{DOV}	C _{LOAD} = 20pF			100	ns
SCLK Rise to SSTRB Valid	t _{STV}	C _{LOAD} = 20pF			100	ns
\overline{CS} Rise to DOUT Disable	t _{DOD}	C _{LOAD} = 20pF	13		85	ns
\overline{CS} Rise to SSTRB Disable	t _{STD}	C _{LOAD} = 20pF	13		85	ns
\overline{CS} Fall to DOUT Enable	t _{DOE}	C _{LOAD} = 20pF			85	ns
\overline{CS} Fall to SSTRB Enable	t _{STE}	C _{LOAD} = 20pF			85	ns
\overline{CS} Pulse Width High	t _{CSSW}		100			ns

Note 1: Tested at $V_{DD1} = V_{DD2} = V_{DD(MIN)}$, COM = GND, unipolar single-ended input mode.

Note 2: Relative accuracy is the deviation of the analog value at any code from its theoretical value after the full-scale range has been calibrated.

Note 3: Offset nulled.

Note 4: Ground the “on” channel; sine wave is applied to all “off” channels.

Note 5: Conversion time is defined as the number of clock cycles multiplied by the clock period; clock has 50% duty cycle.

Note 6: The common-mode range for the analog inputs (CH3–CH0 and COM) is from GND to V_{DD1} .

Note 7: External load should not change during conversion for specified accuracy.

Note 8: ADC performance is limited by the converter’s noise floor, typically 300 μ Vp-p. An external reference below 2.5V compromises the performance of the ADC.

Note 9: Electrical characteristics are guaranteed from $V_{DD1(MIN)} = V_{DD2(MIN)}$ to $V_{DD1(MAX)} = V_{DD2(MIN)}$. For operations beyond this range, see *Typical Operating Characteristics*. For guaranteed specifications beyond the limits, contact the factory.

Note 10: AIN = midscale, unipolar mode. MAX1282 tested with 20pF on DOUT, 20pF on SSTRB, and $f_{SCLK} = 6.4MHz$, 0 to 5V. MAX1283 tested with same loads, $f_{SCLK} = 4.8MHz$, 0 to 3V.

Note 11: SCLK = DIN = GND, $\overline{CS} = V_{DD1}$.

300ksp/400ksp, Single-Supply, 4-Channel, Serial 12-Bit ADCs with Internal Reference

Typical Operating Characteristics

(MAX1282: $V_{DD1} = V_{DD2} = 5.0V$, $f_{SCLK} = 6.4MHz$; MAX1283: $V_{DD1} = V_{DD2} = 3.0V$, $f_{SCLK} = 4.8MHz$; $C_{LOAD} = 20pF$, $4.7\mu F$ capacitor at REF, $0.01\mu F$ capacitor at REFADJ, $T_A = +25^\circ C$, unless otherwise noted.)

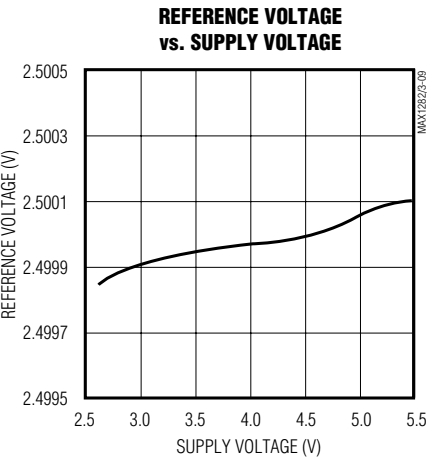
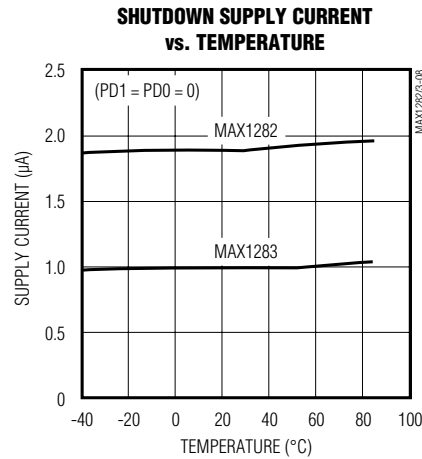
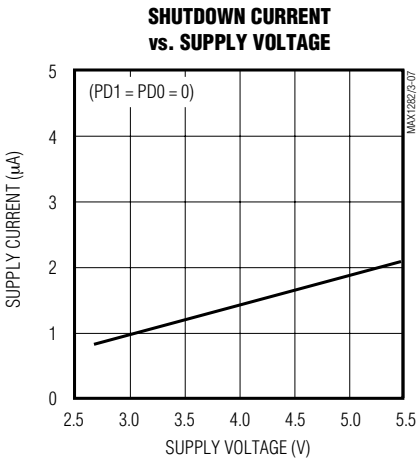
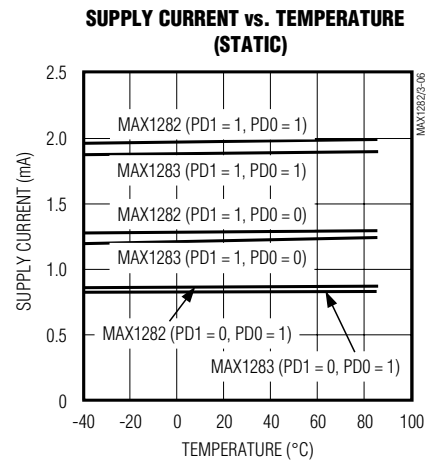
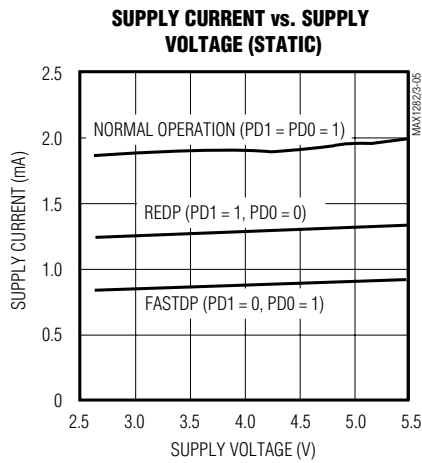
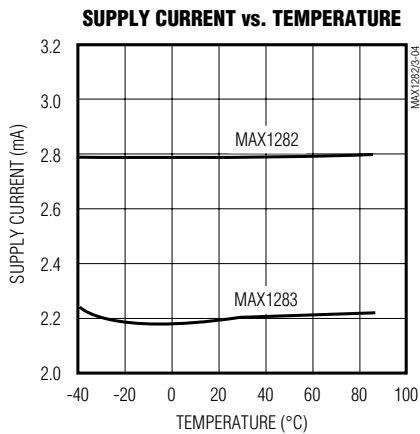
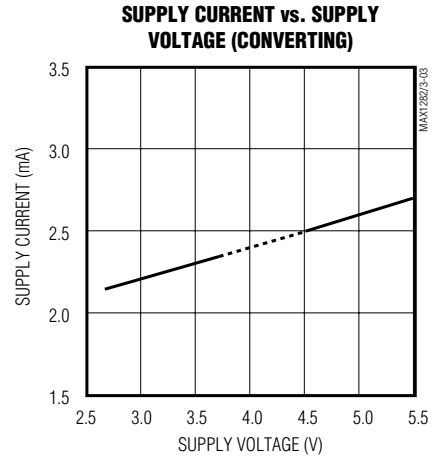
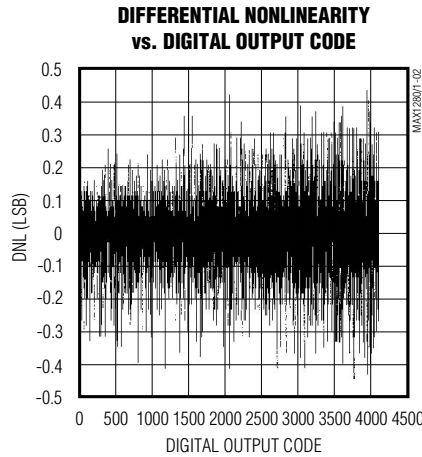
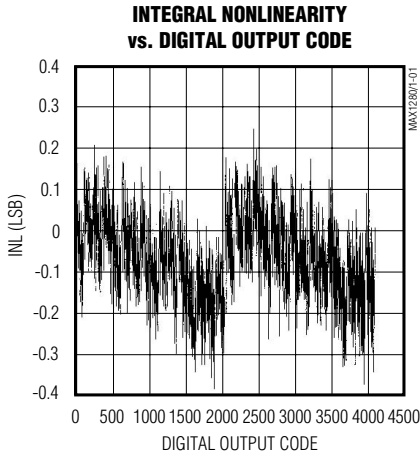

300ksps/400ksps, Single-Supply, 4-Channel, Serial 12-Bit ADCs with Internal Reference

Typical Operating Characteristics (continued)

(MAX1282: $V_{DD1} = V_{DD2} = 5.0V$, $f_{SCLK} = 6.4MHz$; MAX1283: $V_{DD1} = V_{DD2} = 3.0V$, $f_{SCLK} = 4.8MHz$; $C_{LOAD} = 20pF$, $4.7\mu F$ capacitor at REF, $0.01\mu F$ capacitor at REFADJ, $T_A = +25^\circ C$, unless otherwise noted.)

MAX1282/MAX1283

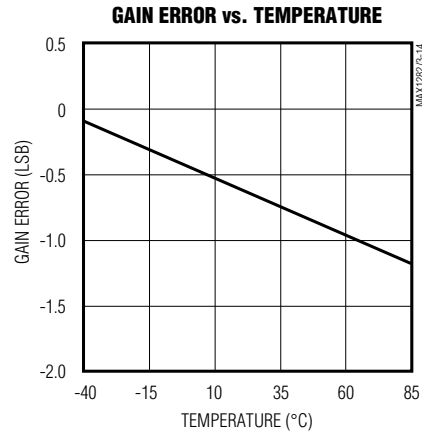
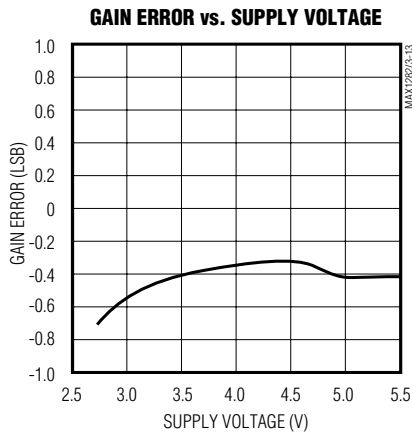
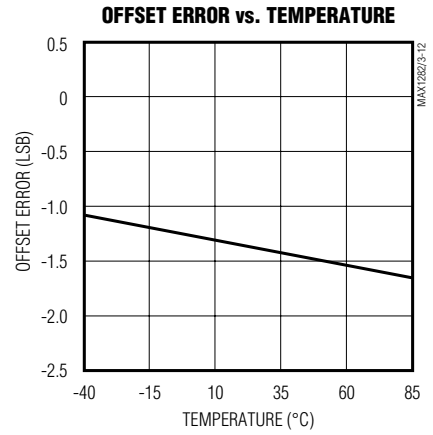
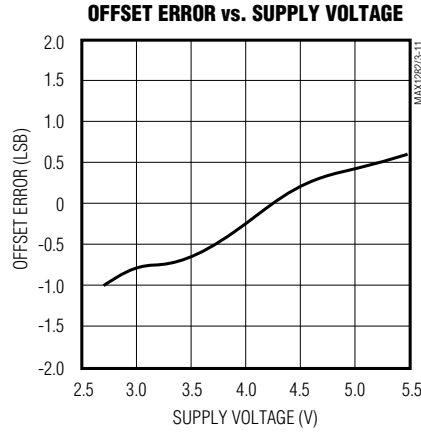
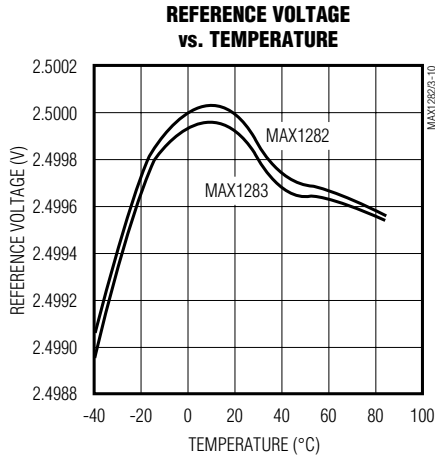

300ksp/400ksp, Single-Supply, 4-Channel, Serial 12-Bit ADCs with Internal Reference

Pin Description

PIN	NAME	FUNCTION
1	V _{DD1}	Positive Supply Voltage
2-5	CH0-CH3	Sampling Analog Inputs
6	COM	Ground Reference for Analog Inputs. COM sets zero-code voltage in single-ended mode. Must be stable to ±0.5LSB.
7	$\overline{\text{SHDN}}$	Active-Low Shutdown Input. Pulling $\overline{\text{SHDN}}$ low shuts down the device, reducing supply current to 2μA (typ).
8	REF	Reference-Buffer Output/ADC Reference Input. Reference voltage for analog-to-digital conversion. In internal reference mode, the reference buffer provides a 2.500V nominal output, externally adjustable at REFADJ. In external reference mode, disable the internal buffer by pulling REFADJ to V _{DD1} .
9	REFADJ	Input to the Reference-Buffer Amplifier. To disable the reference-buffer amplifier, connect REFADJ to V _{DD1} .
10	GND	Ground
11	DOUT	Serial-Data Output. Data is clocked out at SCLK's rising edge. High impedance when $\overline{\text{CS}}$ is high.
12	SSTRB	Serial Strobe Output. SSTRB pulses high for one clock period before the MSB decision. High impedance when $\overline{\text{CS}}$ is high.
13	DIN	Serial-Data Input. Data is clocked in at SCLK's rising edge.
14	$\overline{\text{CS}}$	Active-Low Chip Select. Data will not be clocked into DIN unless $\overline{\text{CS}}$ is low. When $\overline{\text{CS}}$ is high, DOUT and SSTRB are high impedance.
15	SCLK	Serial-Clock Input. Clocks data in and out of serial interface and sets the conversion speed. (Duty cycle must be 40% to 60%.)
16	V _{DD2}	Positive Supply Voltage

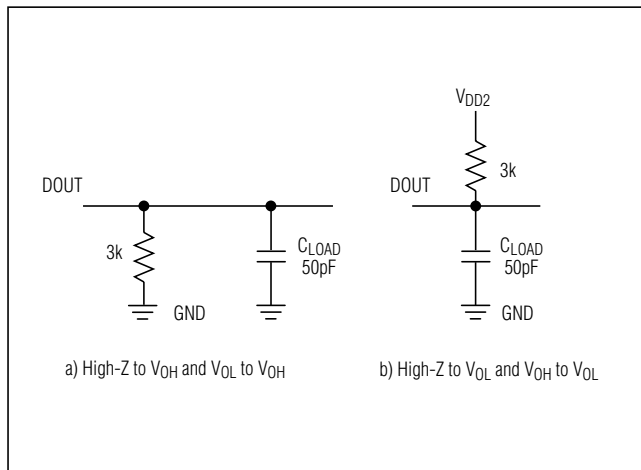

Figure 1. Load Circuits for Enable Time

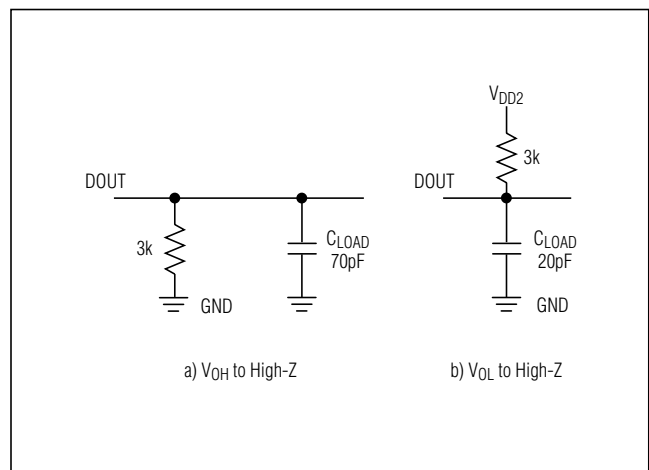

Figure 2. Load Circuits for Disable Time

300ksps/400ksps, Single-Supply, 4-Channel, Serial 12-Bit ADCs with Internal Reference

Detailed Description

The MAX1282/MAX1283 ADCs use a successive-approximation conversion technique and input T/H circuitry to convert an analog signal to a 12-bit digital output. A flexible serial interface provides easy interface to microprocessors (μ Ps). Figure 3 shows a functional diagram of the MAX1282/MAX1283.

Pseudo-Differential Input

The equivalent circuit of Figure 4 shows the MAX1282/MAX1283's input architecture, which is composed of a T/H, input multiplexer, input comparator, switched-capacitor DAC, and reference.

In single-ended mode, the positive input (IN+) is connected to the selected input channel and the negative input (IN-) is set to COM. In differential mode, IN+ and IN- are selected from the following pairs: CH0/CH1 and CH2/CH3. Configure the channels according to Tables 1 and 2.

The MAX1282/MAX1283 input configuration is pseudo-differential because only the signal at IN+ is sampled. The return side (IN-) is connected to the sampling capacitor while converting and must remain stable within ± 0.5 LSB (± 0.1 LSB for best results) with respect to GND during a conversion.

If a varying signal is applied to the selected IN-, its amplitude and frequency must be limited to maintain accuracy. The following equations express the relationship between the maximum signal amplitude and its frequency to maintain ± 0.5 LSB accuracy. Assuming a

sinusoidal signal at IN-, the input voltage is determined by:

$$v_{IN-} = (V_{IN-})\sin(2\pi ft)$$

The maximum voltage variation is determined by:

$$\max \frac{d(v_{IN-})}{dt} = V_{IN-} \cdot 2\pi f \leq \frac{1\text{LSB}}{t_{\text{CONV}}} = \frac{V_{\text{REF}}}{2^{12}t_{\text{CONV}}}$$

A 0.65Vp-p, 60Hz signal at IN- will generate a ± 0.5 LSB error when using a +2.5V reference voltage and a 2.5 μ s conversion time ($15 / f_{\text{SCLK}}$). When a DC reference voltage is used at IN-, connect a 0.1 μ F capacitor to GND to minimize noise at the input.

During the acquisition interval, the channel selected as the positive input (IN+) charges capacitor C_{HOLD} . The acquisition interval spans three SCLK cycles and ends on the falling SCLK edge after the input control word's last bit has been entered. At the end of the acquisition interval, the T/H switch opens, retaining charge on C_{HOLD} as a sample of the signal at IN+. The conversion interval begins with the input multiplexer switching C_{HOLD} from IN+ to IN-. This unbalances node ZERO at the comparator's input. The capacitive DAC adjusts during the remainder of the conversion cycle to restore node ZERO to $V_{\text{DD1}} / 2$ within the limits of 12-bit resolution. This action is equivalent to transferring a $12\text{pF} \times (V_{\text{IN+}} - V_{\text{IN-}})$ charge from C_{HOLD} to the binary-weighted capacitive DAC, which in turn forms a digital representation of the analog input signal.

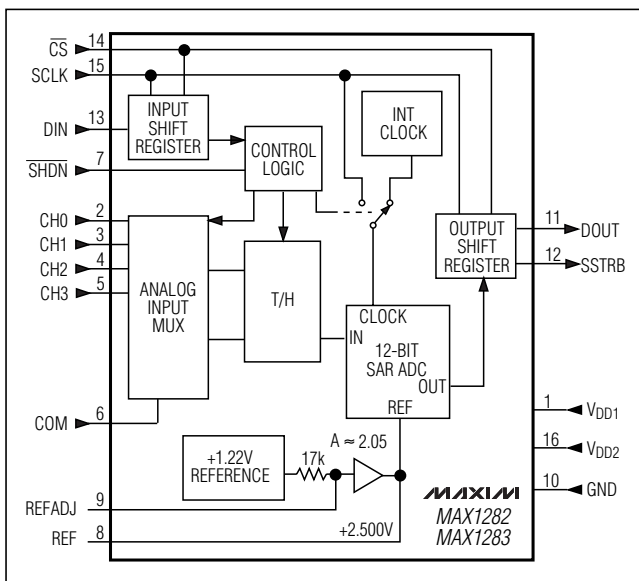

Figure 3. Functional Diagram

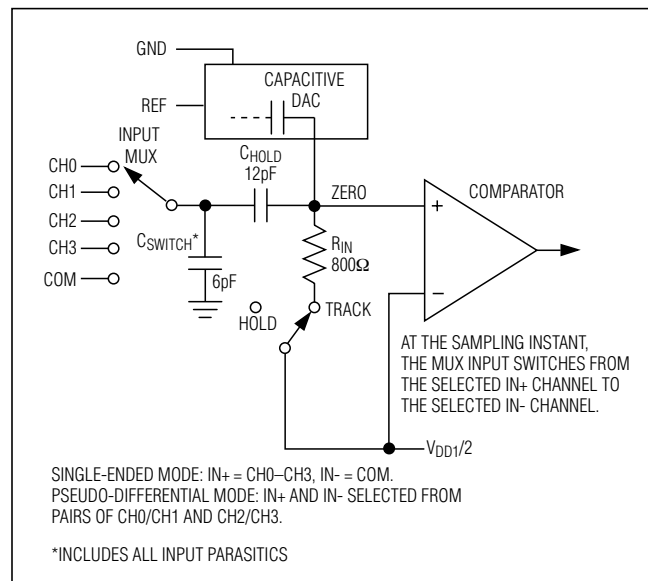

Figure 4. Equivalent Input Circuit

300ksps/400ksps, Single-Supply, 4-Channel, Serial 12-Bit ADCs with Internal Reference

Table 1. Channel Selection in Single-Ended Mode (SGL/DIF = 1)

SEL2	SEL1	SEL0	CH0	CH1	CH2	CH3	COM
0	0	1	+				-
1	0	1		+			-
0	1	0			+		-
1	1	0				+	-

Table 2. Channel Selection in Pseudo-Differential Mode (SGL/DIF = 0)

SEL2	SEL1	SEL0	CH0	CH1	CH2	CH3
0	0	1	+	-		
0	1	0			+	-
1	0	1	-	+		
1	1	0			-	+

Track/Hold

The T/H enters its tracking mode on the falling clock edge after the fifth bit of the 8-bit control word has been shifted in. It enters its hold mode on the falling clock edge after the eighth bit of the control word has been shifted in. If the converter is set up for single-ended inputs, IN- is connected to COM and the converter samples the "+" input. If the converter is set up for differential inputs, the difference of [(IN+) - (IN-)] is converted. At the end of the conversion, the positive input connects back to IN+ and CHOLD charges to the input signal.

The time required for the T/H to acquire an input signal is a function of how quickly its input capacitance is charged. If the input signal's source impedance is high, the acquisition time lengthens, and more time must be allowed between conversions. The acquisition time, t_{ACQ} , is the maximum time the device takes to acquire the signal and the minimum time needed for the signal to be acquired. It is calculated by the following equation:

$$t_{ACQ} = 9 \times (R_S + R_{IN}) \times 18\text{pF}$$

where $R_{IN} = 800\Omega$ and R_S = the source impedance of the input signal; t_{ACQ} is never less than 400ns (MAX1282) or 625ns (MAX1283). Note that source impedances below $2k\Omega$ do not significantly affect the ADC's AC performance.

Input Bandwidth

The ADC's input tracking circuitry has a 6MHz (MAX1282) or 3MHz (MAX1283) small-signal bandwidth, so it is possible to digitize high-speed transient

events and measure periodic signals with bandwidths exceeding the ADC's sampling rate by using under-sampling techniques. To avoid high-frequency signals being aliased into the frequency band of interest, anti-alias filtering is recommended.

Analog Input Protection

Internal protection diodes, which clamp the analog input to V_{DD1} and GND, allow the channel input pins to swing from GND - 0.3V to $V_{DD1} + 0.3V$ without damage. However, for accurate conversions near full scale, the inputs must not exceed V_{DD1} by more than 50mV or be lower than GND by 50mV.

If the analog input exceeds 50mV beyond the supplies, do not allow the input current to exceed 2mA.

Starting a Conversion

Start a conversion by clocking a control byte into DIN. With \overline{CS} low, each rising edge on SCLK clocks a bit from DIN into the MAX1282/MAX1283's internal shift register. After \overline{CS} falls, the first arriving logic "1" bit defines the control byte's MSB. Until this first "start" bit arrives, any number of logic "0" bits can be clocked into DIN with no effect. Table 3 shows the control-byte format.

The MAX1282/MAX1283 are compatible with SPI/QSPI/MICROWIRE devices. For SPI, select the correct clock polarity and sampling edge in the SPI control registers: set CPOL = 0 and CPHA = 0. MICROWIRE, SPI, and QSPI all transmit a byte and receive a byte at the same time. Using the *Typical Operating Circuit*, the simplest software interface requires only three 8-bit transfers to perform a conversion (one 8-bit transfer to configure the ADC, and two more 8-bit transfers to clock out the

300ksps/400ksps, Single-Supply, 4-Channel, Serial 12-Bit ADCs with Internal Reference

conversion result). (See Figure 16 for MAX1282/MAX1283 QSPI connections.)

Simple Software Interface

Make sure the CPU's serial interface runs in master mode so the CPU generates the serial clock. Choose a clock frequency from 500kHz to 6.4MHz (MAX1282) or 4.8MHz (MAX1283).

- 1) Set up the control byte and call it TB1. TB1 should be in the format: 1XXXXXX binary, where the Xs denote the particular channel, selected conversion mode, and power mode.
- 2) Use a general-purpose I/O line on the CPU to pull \overline{CS} low.
- 3) Transmit TB1 and, simultaneously, receive a byte and call it RB1. Ignore RB1.
- 4) Transmit a byte of all zeros (\$00 hex) and, simultaneously, receive byte RB2.
- 5) Transmit a byte of all zeros (\$00 hex) and, simultaneously, receive byte RB3.
- 6) Pull \overline{CS} high.

Figure 5 shows the timing for this sequence. Bytes RB2 and RB3 contain the result of the conversion, padded with three leading zeros, and one trailing zero. The total conversion time is a function of the serial-clock frequency and the amount of idle time between 8-bit transfers. To avoid excessive T/H droop, make sure the total conversion time does not exceed 120 μ s.

Digital Output

In unipolar input mode, the output is straight binary (Figure 13). For bipolar input mode, the output is two's complement (Figure 14). Data is clocked out on the rising edge of SCLK in MSB-first format.

Serial Clock

The external clock not only shifts data in and out, but it also drives the analog-to-digital conversion steps. SSTRB pulses high for one clock period after the last bit of the control byte. Successive-approximation bit decisions are made and appear at DOUT on each of the next 12 SCLK rising edges, MSB first (Figure 5). SSTRB and DOUT go into a high-impedance state when \overline{CS} goes high; after the next \overline{CS} falling edge, SSTRB outputs a logic low. Figure 6 shows the detailed serial-interface timings.

The conversion must complete in 120 μ s or less, or droop on the sample-and-hold capacitors may degrade conversion results.

Data Framing

The falling edge of \overline{CS} does **not** start a conversion. The first logic high clocked into DIN is interpreted as a start bit and defines the first bit of the control byte. A conversion starts on SCLK's falling edge, after the eighth bit of the control byte (the PD0 bit) is clocked into DIN. The start bit is defined as follows:

The first high bit clocked into DIN with \overline{CS} low any time the converter is idle, e.g., after V_{DD1} and V_{DD2} are applied.

or

The first high bit clocked into DIN after B6 of a conversion in progress is clocked onto the DOUT pin (Figure 7).

Once a start bit has been recognized, the current conversion may only be terminated by pulling \overline{SHDN} low.

The fastest the MAX1282/MAX1283 can run with \overline{CS} held low between conversions is 16 clocks per conversion. Figure 7 shows the serial-interface timing necessary to perform a conversion every 16 SCLK cycles. If \overline{CS} is tied low and SCLK is continuous, guarantee a start bit by first clocking in 16 zeros.

Applications Information

Power-On Reset

When power is first applied, and if \overline{SHDN} is not pulled low, internal power-on reset circuitry activates the MAX1282/MAX1283 in normal operating mode, ready to convert with SSTRB = low. After the power supplies stabilize, the internal reset time is 10 μ s, and no conversions should be performed during this phase. If \overline{CS} is low, the first logic 1 on DIN is interpreted as a start bit. Until a conversion takes place, DOUT shifts out zeros. Additionally, wait for the reference to stabilize when using the internal reference.

Power Modes

Save power by placing the converter in one of two low-current operating modes or in full power-down between conversions. Select the power-down mode through bit 1 and bit 0 of the DIN control byte (Tables 3 and 4), or force the converter into hardware shutdown by driving \overline{SHDN} to GND.

The software power-down modes take effect after the conversion is completed; \overline{SHDN} overrides any software power mode and immediately stops any conversion in progress. In software power-down mode, the serial interface remains active while waiting for a new control byte to start conversion and switch to full-power mode.

300ksps/400ksps, Single-Supply, 4-Channel, Serial 12-Bit ADCs with Internal Reference

Table 3. Control-Byte Format

BIT 7 (MSB)	BIT 6	BIT 5	BIT 4	BIT 3	BIT 2	BIT 1	BIT 0 (LSB)
START	SEL2	SEL1	SEL0	UNI/BIP	SGL/DIF	PD1	PD0

BIT	NAME	DESCRIPTION															
7(MSB)	START	The first logic 1 bit after \overline{CS} goes low defines the beginning of the control byte.															
6 5 4	SEL2 SEL1 SEL0	These three bits select which of the eight channels are used for the conversion (Tables 1 and 2).															
3	UNI/BIP	1 = unipolar, 0 = bipolar. Selects unipolar or bipolar conversion mode. In unipolar mode, an analog input signal from 0 to V_{REF} can be converted; in bipolar mode, the differential signal can range from $-V_{REF}/2$ to $+V_{REF}/2$.															
2	SGL/DIF	1 = single ended, 0 = pseudo-differential. Selects single-ended or pseudo-differential conversions. In single-ended mode, input signal voltages are referred to COM. In pseudo-differential mode, the voltage difference between two channels is measured (Tables 1 and 2).															
1 0(LSB)	PD1 PD0	Select operating mode. <table border="1"> <thead> <tr> <th>PD1</th> <th>PD0</th> <th>Mode</th> </tr> </thead> <tbody> <tr> <td>0</td> <td>0</td> <td>Full power-down</td> </tr> <tr> <td>0</td> <td>1</td> <td>Fast power-down</td> </tr> <tr> <td>1</td> <td>0</td> <td>Reduced power</td> </tr> <tr> <td>1</td> <td>1</td> <td>Normal operation</td> </tr> </tbody> </table>	PD1	PD0	Mode	0	0	Full power-down	0	1	Fast power-down	1	0	Reduced power	1	1	Normal operation
PD1	PD0	Mode															
0	0	Full power-down															
0	1	Fast power-down															
1	0	Reduced power															
1	1	Normal operation															

Table 4. Software-Controlled Power Modes

PD1/PD0	MODE	TOTAL SUPPLY CURRENT		CIRCUIT SECTIONS*	
		CONVERTING (mA)	AFTER CONVERSION	INPUT COMPARATOR	REFERENCE
00	Full Power-Down (FULLPD)	2.5	2 μ A	Off	Off
01	Fast Power-Down (FASTPD)	2.5	0.9mA	Reduced Power	On
10	Reduced-Power Mode (REDP)	2.5	1.3mA	Reduced Power	On
11	Normal Operating	2.5	2.0mA	Full Power	On

*Circuit operation between conversions; during conversion all circuits are fully powered up.

Once conversion is completed, the device goes into the programmed power mode until a new control byte is written.

The power-up delay is dependent on the power-down state. Software low-power modes will be able to start conversion immediately when running at decreased clock rates (see *Power-Down Sequencing*). Upon power-on reset, when exiting software full power-down mode, or when exiting hardware shutdown, the device goes immediately into full-power mode and is ready to

convert after 2 μ s when using an external reference. When using the internal reference, wait for the typical power-up delay from a full power-down (software or hardware) as shown in Figure 8.

Software Power-Down

Software power-down is activated using bits PD1 and PD0 of the control byte. When software power-down is asserted, the ADC completes the conversion in

300ksp/400ksp, Single-Supply, 4-Channel, Serial 12-Bit ADCs with Internal Reference

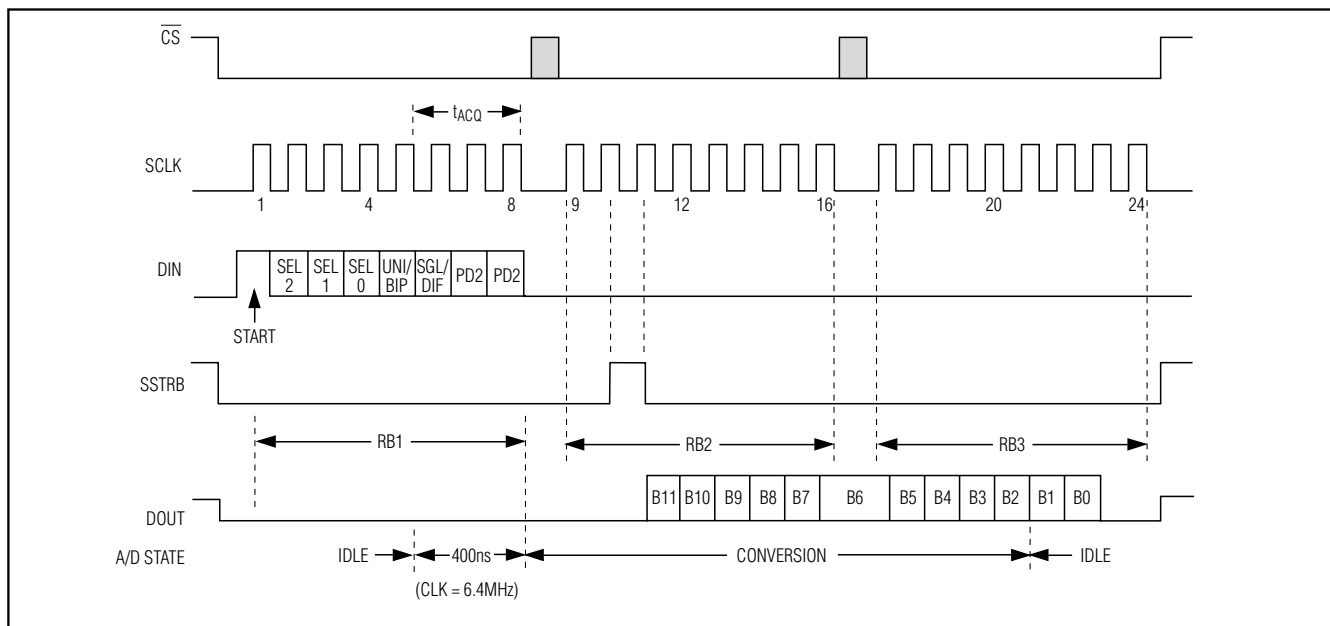

Figure 5. Single-Conversion Timing

progress and powers down into the specified low-quiescent-current state (2 μ A, 0.9mA, or 1.3mA).

The first logic 1 on DIN is interpreted as a start bit and puts the MAX1282/MAX1283 into its full-power mode. Following the start bit, the data input word or control byte also determines the next power-down state. For example, if the DIN word contains PD1 = 0 and PD0 = 1, a 0.9mA power-down resumes after one conversion. Table 4 details the four power modes with the corresponding supply current and operating sections.

Hardware Power-Down

Pulling $\overline{\text{SHDN}}$ low places the converter in hardware power-down. Unlike software power-down mode, the conversion is not completed; it stops coincidentally with $\overline{\text{SHDN}}$ being brought low. When returning to normal operation—from $\overline{\text{SHDN}}$, with an external reference—the MAX1282/MAX1283 can be considered fully powered up within 2 μ s of actively pulling $\overline{\text{SHDN}}$ high. When using the internal reference, the conversion should be initiated only when the reference has settled; its recovery time is dependent on the external bypass capacitors and the time between conversions.

Power-Down Sequencing

The MAX1282/MAX1283 auto power-down modes can save considerable power when operating at less than maximum sample rates. Figures 9 and 10 show the average supply current as a function of the sampling rate. The following sections discuss the various power-down sequences. Other combinations of clock rates

and power-down modes may attain the lowest power consumption in other applications.

Using Full Power-Down Mode

Full power-down mode (FULLPD) achieves the lowest power consumption, up to 1000 conversions per channel per second. Figure 9a shows the MAX1283's power consumption for one- or four-channel conversions utilizing full power-down mode (PD1 = PD0 = 0), with the internal reference and conversion controlled at the maximum clock speed. A 0.01 μ F bypass capacitor at REFADJ forms an RC filter with the internal 17k Ω reference resistor, with a 170 μ s time constant. To achieve full 12-bit accuracy, nine time constants or 1.5ms are required after power-up if the bypass capacitor is fully discharged between conversions. Waiting this 1.5ms duration in fast power-down (FASTPD) or reduced-power (REDP) mode instead of in full power-up can further reduce power consumption. This is achieved by using the sequence shown in Figure 11a.

Figure 9b shows the MAX1283's power consumption for one- or four-channel conversions utilizing FULLPD mode (PD1 = PD0 = 0), with an external reference and conversion controlled at the maximum clock speed. One dummy conversion to power up the device is needed, but no waiting time is necessary to start the second conversion, thereby achieving lower power consumption as low as half the full sampling rate.

300ksp/400ksp, Single-Supply, 4-Channel, Serial 12-Bit ADCs with Internal Reference

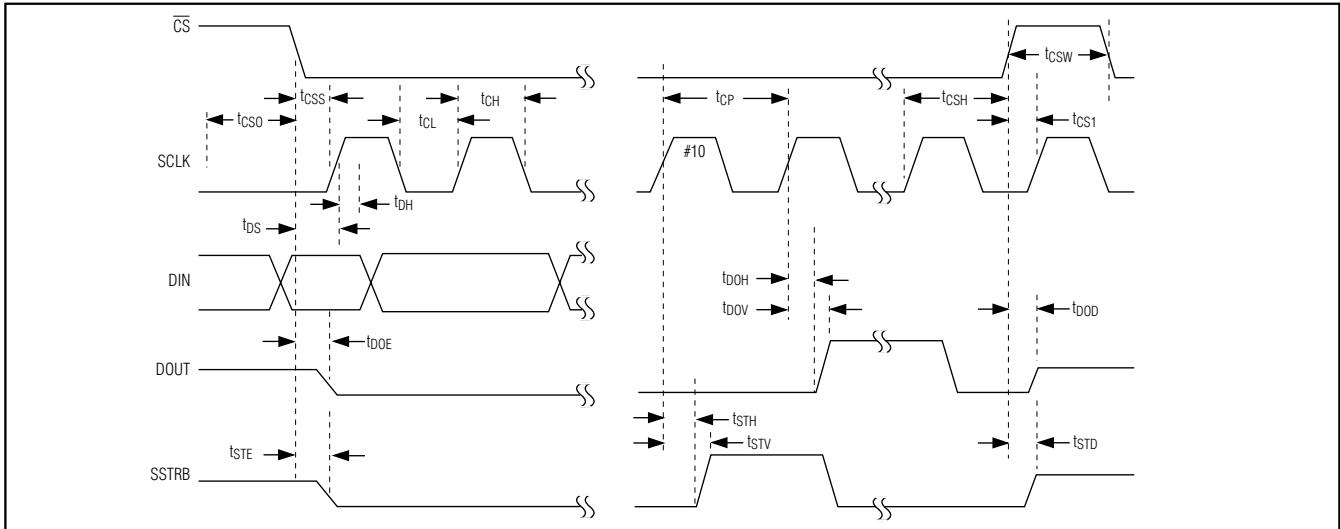

Figure 6. Detailed Serial-Interface Timing

Using Fast Power-Down and Reduced-Power Modes

FASTPD and REDP modes achieve the lowest power consumption at speeds close to the maximum sampling rate. Figure 10 shows the MAX1283's power consumption in FASTPD mode (PD1 = 0, PD0 = 1), REDP mode (PD1 = 1, PD0 = 0), and, for comparison, normal operating mode (PD1 = 1, PD0 = 1). The figure shows power consumption using the specified power-down mode, with the internal reference and conversion controlled at the maximum clock speed. The clock speed in FASTPD or REDP should be limited to 4.8MHz for the MAX1282/MAX1283. FULLPD mode may provide increased power savings in applications where the MAX1282/MAX1283 are inactive for long periods of time, but intermittent bursts of high-speed conversions are required. Figure 11b shows FASTPD and REDP timing.

Internal and External References

The MAX1282/MAX1283 can be used with an internal or external reference voltage. An external reference can be connected directly at REF or at the REFADJ pin.

An internal buffer is designed to provide 2.5V at REF for the MAX1282/MAX1283. The internally trimmed 1.22V reference is buffered with a 2.05 gain.

Internal Reference

The MAX1282/MAX1283's full-scale range with the internal reference is 2.5V with unipolar inputs and $\pm 1.25V$ with bipolar inputs. The internal reference voltage is adjustable by $\pm 100mV$ with the circuit in Figure 12.

External Reference

The MAX1282/MAX1283's external reference can be placed at the input (REFADJ) or the output (REF) of the internal reference-buffer amplifier. The REFADJ input impedance is typically 17k Ω . At REF, the DC input resistance is a minimum of 18k Ω . During conversion, an external reference at REF must deliver up to 350 μA DC load current and have 10 Ω or less output impedance. If the reference has a higher output impedance or is noisy, bypass it close to the REF pin with a 4.7 μF capacitor.

Table 5. Full Scale and Zero Scale

UNIPOLAR MODE		BIPOLAR MODE		
Full Scale	Zero Scale	Positive Full Scale	Zero Scale	Negative Full Scale
$V_{REF} + V_{COM}$	V_{COM}	$V_{REF} / 2 + V_{COM}$	V_{COM}	$V_{REF} / 2 + V_{COM}$

300ksp/400ksp, Single-Supply, 4-Channel, Serial 12-Bit ADCs with Internal Reference

MAX1282/MAX1283

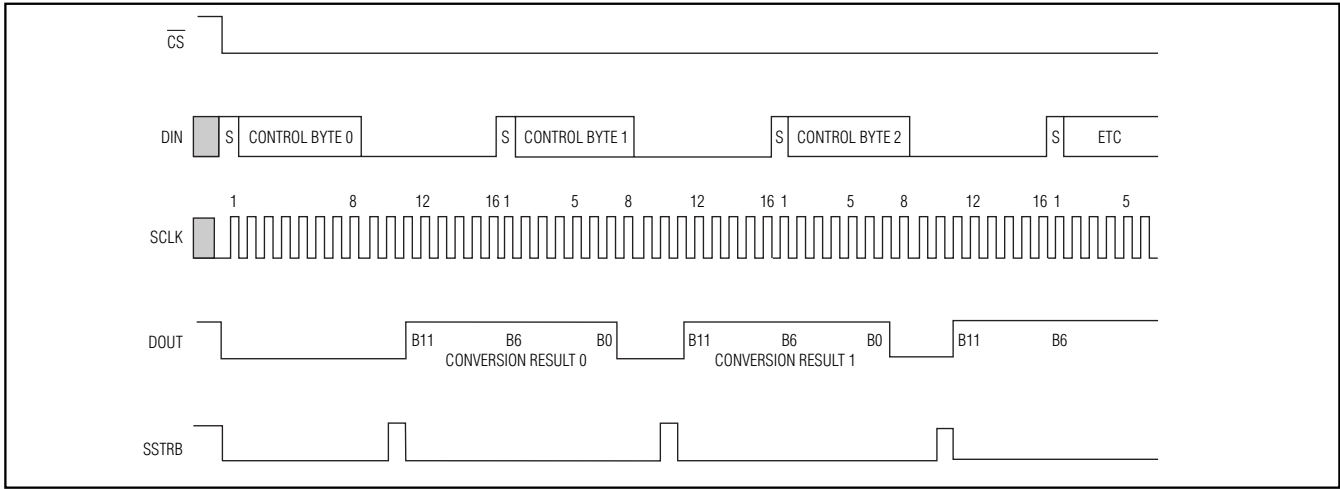

Figure 7. Continuous 16-Clock/Conversion Timing

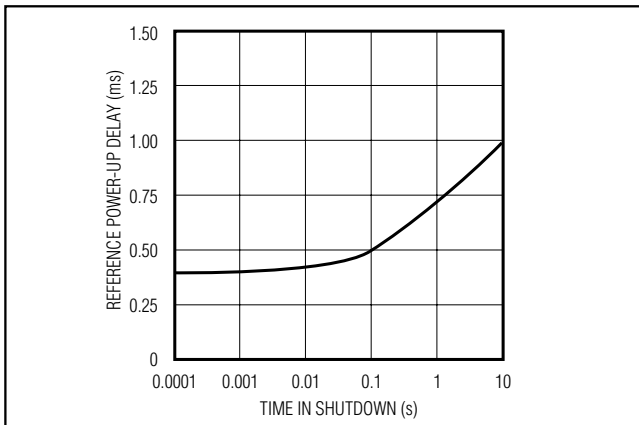

Figure 8. Reference Power-Up Delay vs. Time in Shutdown

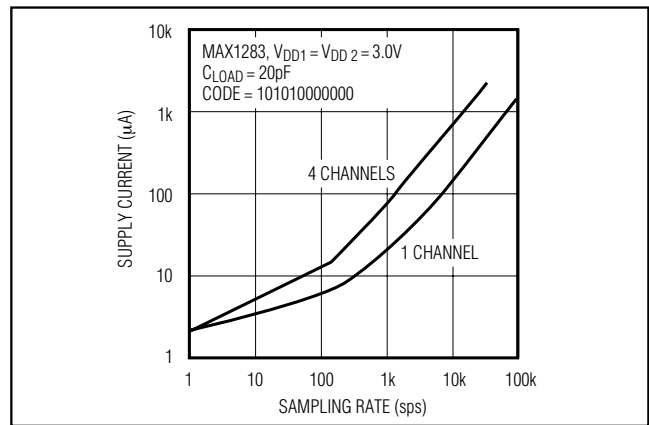

Figure 9b. Average Supply Current vs. Conversion Rate with External Reference in FULLPD

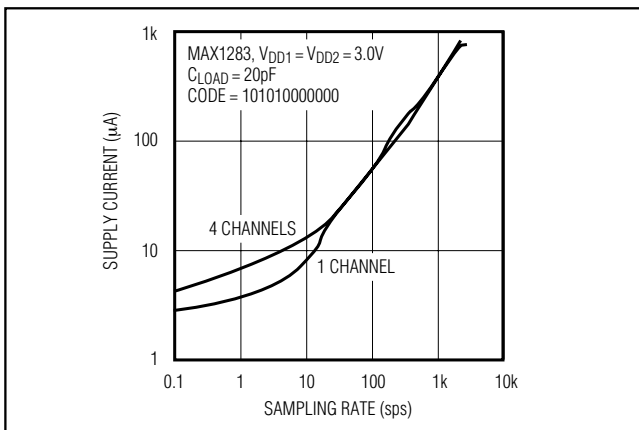

Figure 9a. Average Supply Current vs. Conversion Rate with Internal Reference in FULLPD

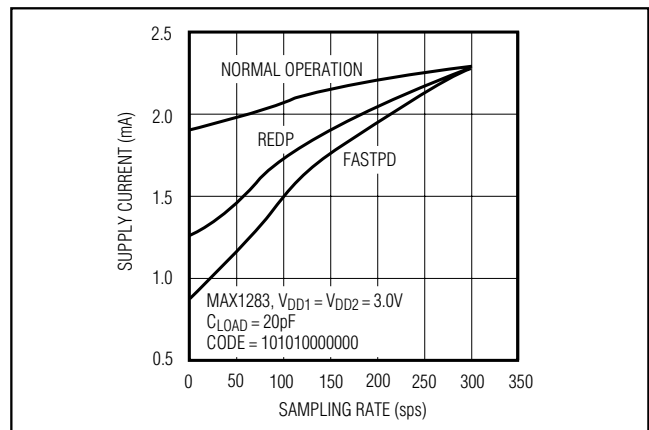

Figure 10. Average Supply Current vs. Sampling Rate (in FASTPD, REDP, and Normal Operation)

300ksps/400ksps, Single-Supply, 4-Channel, Serial 12-Bit ADCs with Internal Reference

To use the direct REF input, disable the internal buffer by connecting REFADJ to V_{DD1}. Using the REFADJ input makes buffering the external reference unnecessary.

Transfer Function

Table 5 shows the full-scale voltage ranges for unipolar and bipolar modes.

Figure 13 depicts the nominal, unipolar input/output (I/O) transfer function, and Figure 14 shows the bipolar I/O transfer function. Code transitions occur halfway between successive-integer LSB values. Output coding is binary, with 1LSB = 0.61mV (2.500V / 4096) for unipolar operation, and 1LSB = 0.61mV [(2.500V / 2) / 4096] for bipolar operation.

Layout, Grounding, and Bypassing

For best performance, use PC boards; wire-wrap boards are not recommended. Board layout should ensure that digital and analog signal lines are separated from each other. Do not run analog and digital (especially clock) lines parallel to one another, or digital lines underneath the ADC package.

Figure 15 shows the recommended system ground connections. Establish a single-point analog ground (star ground point) at GND. Connect all other analog grounds to the star ground. Connect the digital system ground to this ground only at this point. For lowest-noise operation, the ground return to the star ground's power supply should be low impedance and as short as possible.

High-frequency noise in the V_{DD1} power supply may affect the high-speed comparator in the ADC. Bypass the supply to the star ground with 0.1μF and 10μF capacitors close to V_{DD1} of the MAX1282/MAX1283. Minimize capacitor lead lengths for best supply-noise rejection. If the power supply is very noisy, a 10Ω resistor can be connected as a lowpass filter (Figure 15).

High-Speed Digital Interfacing with QSPI

The MAX1282/MAX1283 can interface with QSPI using the circuit in Figure 16 (CPOL = 0, CPHA = 0). This QSPI circuit can be programmed to do a conversion on each of the four channels. The result is stored in memory without taxing the CPU, since QSPI incorporates its own microsequencer.

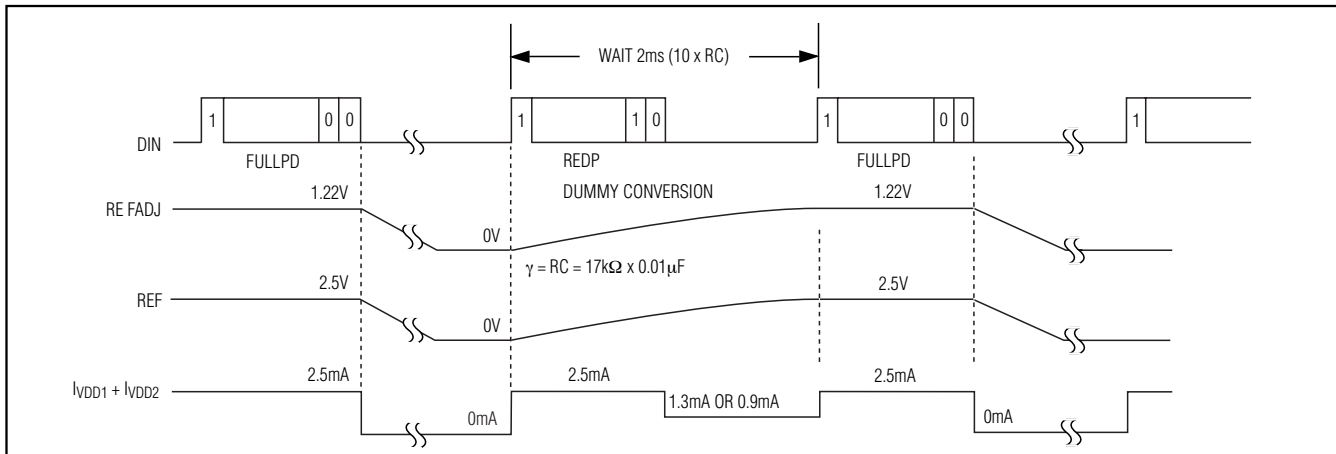

Figure 11a. Full Power-Down Timing

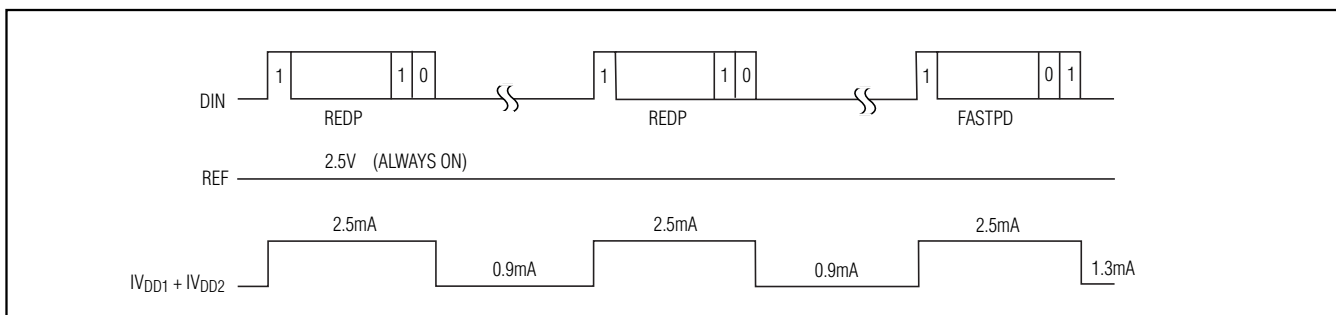

Figure 11b. FASTPD and REDP Timing

300ksp/s/400ksp/s, Single-Supply, 4-Channel, Serial 12-Bit ADCs with Internal Reference

MAX1282/MAX1283

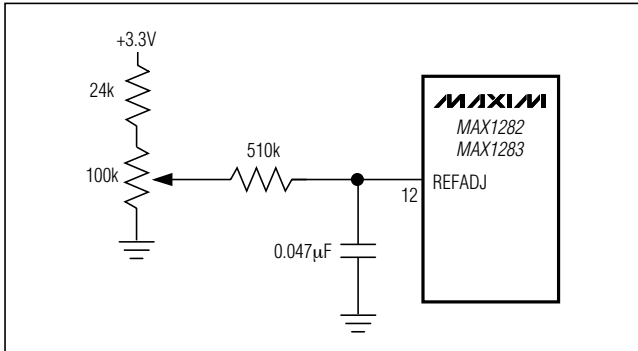

Figure 12. MAX1282/MAX1283 Reference-Adjust Circuit

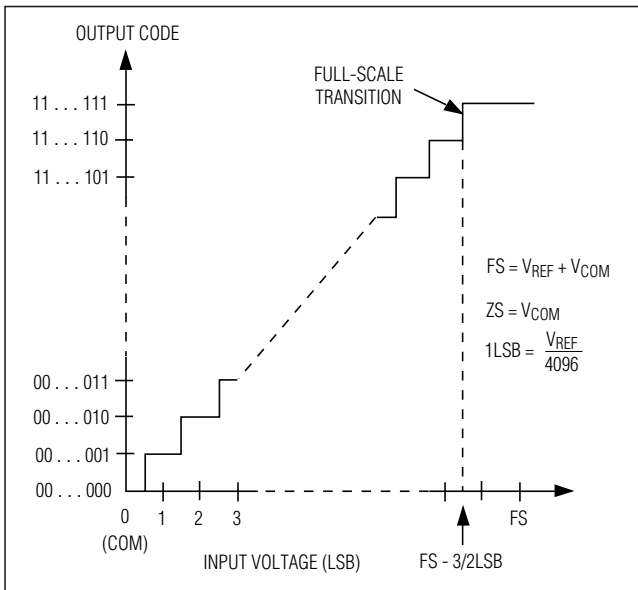

Figure 13. Unipolar Transfer Function, Full Scale (FS) = $V_{REF} + V_{COM}$, Zero Scale (ZS) = V_{COM}

TMS320LC3x Interface

Figure 17 shows an application circuit to interface the MAX1282/MAX1283 to the TMS320 in external clock mode. The timing diagram for this interface circuit is shown in Figure 18.

Use the following steps to initiate a conversion in the MAX1282/MAX1283 and to read the results:

- 1) The TMS320 should be configured with CLKX (transmit clock) as an active-high output clock and CLKR (TMS320 receive clock) as an active-high input clock. CLKX and CLKR on the TMS320 are connected to the MAX1282/MAX1283's SCLK input.

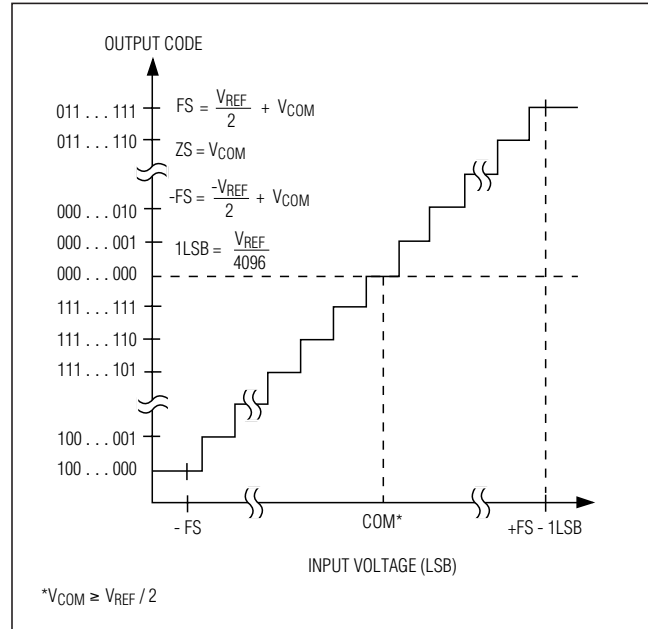

Figure 14. Bipolar Transfer Function, Full Scale (FS) = $V_{REF} / 2 + V_{COM}$, Zero Scale (ZS) = V_{COM}

- 2) The MAX1282/MAX1283's \overline{CS} pin is driven low by the TMS320's XF_ I/O port to enable data to be clocked into the MAX1282/MAX1283's DIN pin.
- 3) An 8-bit word (1XXXXX11) should be written to the MAX1282/MAX1283 to initiate a conversion and place the device into normal operating mode. See Table 3 to select the proper XXXXX bit values for your specific application.
- 4) The MAX1282/MAX1283's SSTRB output is monitored through the TMS320's FSR input. A falling edge on the SSTRB output indicates that the conversion is in progress and data is ready to be received from the device.
- 5) The TMS320 reads in 1 data bit on each of the next 16 rising edges of SCLK. These data bits represent the 12-bit conversion result followed by 4 trailing bits, which should be ignored.
- 6) Pull \overline{CS} high to disable the MAX1282/MAX1283 until the next conversion is initiated.

300ksps/400ksps, Single-Supply, 4-Channel, Serial 12-Bit ADCs with Internal Reference

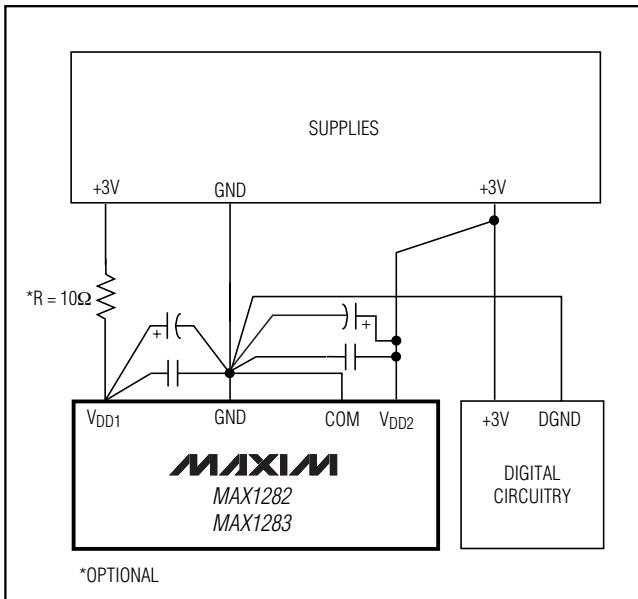

Figure 15. Power-Supply Grounding Connection

Definitions

Integral Nonlinearity

Integral nonlinearity (INL) is the deviation of the values from a straight line on an actual transfer function. This straight line can be a best-straight-line fit or a line drawn between the endpoints of the transfer function, once offset and gain errors have been nullified. The static linearity parameters for the MAX1282/MAX1283 are measured using the best straight-line fit method.

Differential Nonlinearity

Differential nonlinearity (DNL) is the difference between an actual step width and the ideal value of 1LSB. A DNL error specification of less than 1LSB guarantees no missing codes and a monotonic transfer function.

Aperture Width

Aperture width (t_{AW}) is the time the T/H circuit requires to disconnect the hold capacitor from the input circuit (for instance, to turn off the sampling bridge, and put the T/H unit in hold mode).

Aperture Jitter

Aperture jitter (t_{AJ}) is the sample-to-sample variation in the time between the samples.

Aperture Delay

Aperture delay (t_{AD}) is the time defined between the rising edge of the sampling clock and the instant when an actual sample is taken.

Signal-to-Noise Ratio (SNR)

For a waveform perfectly reconstructed from digital samples, the SNR is the ratio of the full-scale analog input (RMS value) to the RMS quantization error (residual error). The ideal, theoretical minimum analog-to-digital noise is caused only by quantization error and results directly from the ADC's resolution (N bits):

$$\text{SNR} = (6.02 \times N + 1.76) \text{dB}$$

In reality, there are other noise sources besides quantization noise, including thermal noise, reference noise, clock jitter, etc. Therefore, SNR is calculated by taking the ratio of the RMS signal to the RMS noise, which includes all spectral components minus the fundamental, the first five harmonics, and the DC offset.

Signal-to-Noise Plus Distortion (SINAD)

SINAD is the ratio of the fundamental input frequency's RMS amplitude to RMS equivalent of all other ADC output signals:

$$\text{SINAD (dB)} = 20 \times \log (\text{Signal}_{\text{RMS}} / \text{Noise}_{\text{RMS}})$$

Effective Number of Bits (ENOB)

ENOB indicates the global accuracy of an ADC at a specific input frequency and sampling rate. An ideal ADC's error consists only of quantization noise. With an input range equal to the ADC's full-scale range, calculate ENOB as follows:

$$\text{ENOB} = (\text{SINAD} - 1.76) / 6.02$$

Total Harmonic Distortion (THD)

THD is the ratio of the RMS sum of the input signal's first five harmonics to the fundamental itself. This is expressed as:

$$\text{THD} = 20 \times \log \frac{\left(\sqrt{V_2^2 + V_3^2 + V_4^2 + V_4^2 + V_5^2} \right)}{V_1}$$

where V_1 is the fundamental amplitude, and V_2 through V_5 are the amplitudes of the 2nd- through 5th-order harmonics.

Spurious-Free Dynamic Range (SFDR)

SFDR is the ratio of the RMS amplitude of the fundamental (maximum signal component) to the RMS value of the next-largest distortion component.

300kspS/400kspS, Single-Supply, 4-Channel, Serial 12-Bit ADCs with Internal Reference

MAX1282/MAX1283

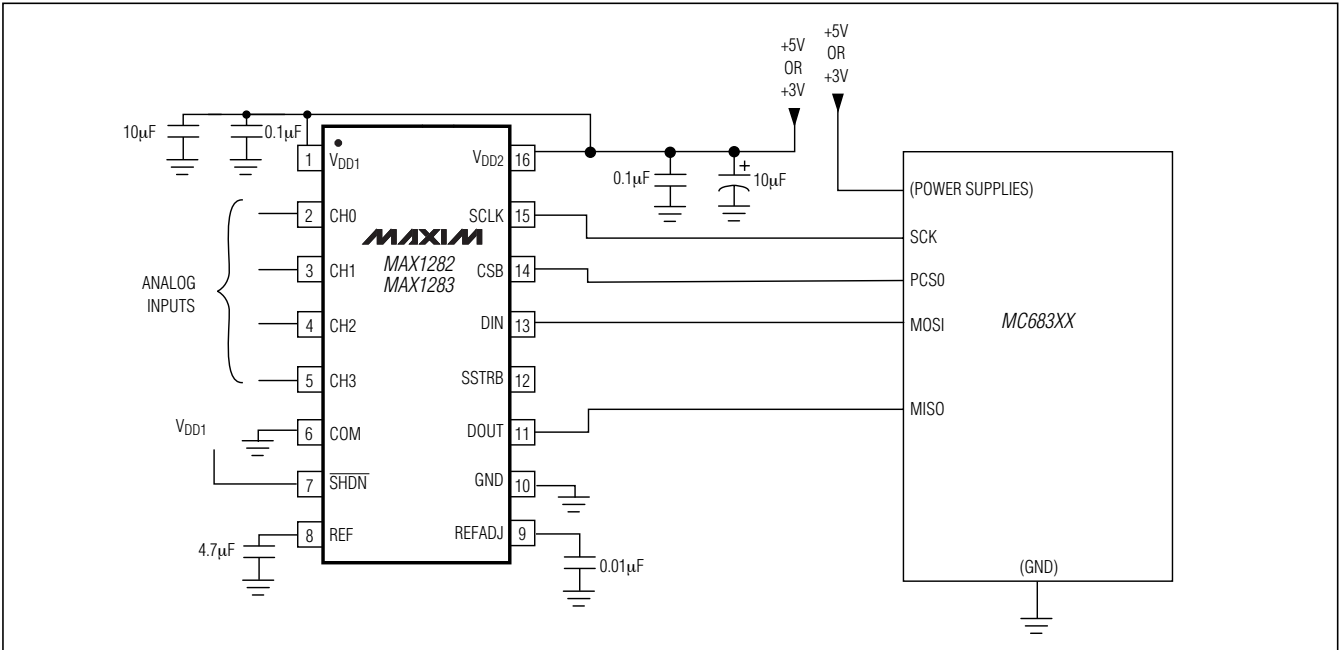

Figure 16. QSPI Connections

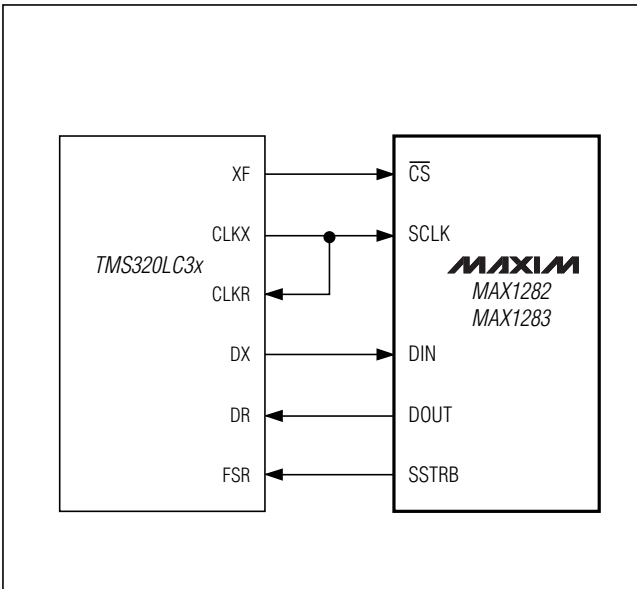

Figure 17. MAX1282/MAX1283-to-TMS320 Serial Interface

300ksp/400ksp, Single-Supply, 4-Channel, Serial 12-Bit ADCs with Internal Reference

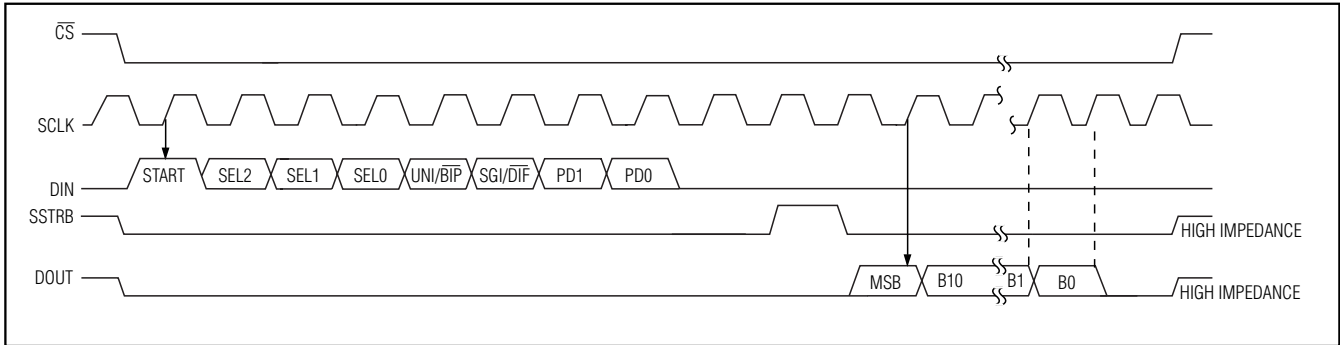
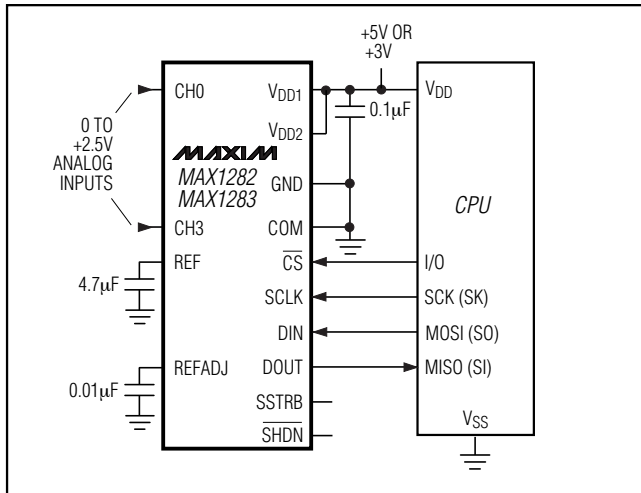

Figure 18. MAX1282/MAX1283-to-TMS320 Serial Interface

Typical Operating Circuit



Chip Information

TRANSISTOR COUNT: 4286

PROCESS: BiCMOS

300ksp/400ksp, Single-Supply, 4-Channel, Serial 12-Bit ADCs with Internal Reference

Package Information

(The package drawing(s) in this data sheet may not reflect the most current specifications. For the latest package outline information go to www.maxim-ic.com/packages.)

MAX1282/MAX1283

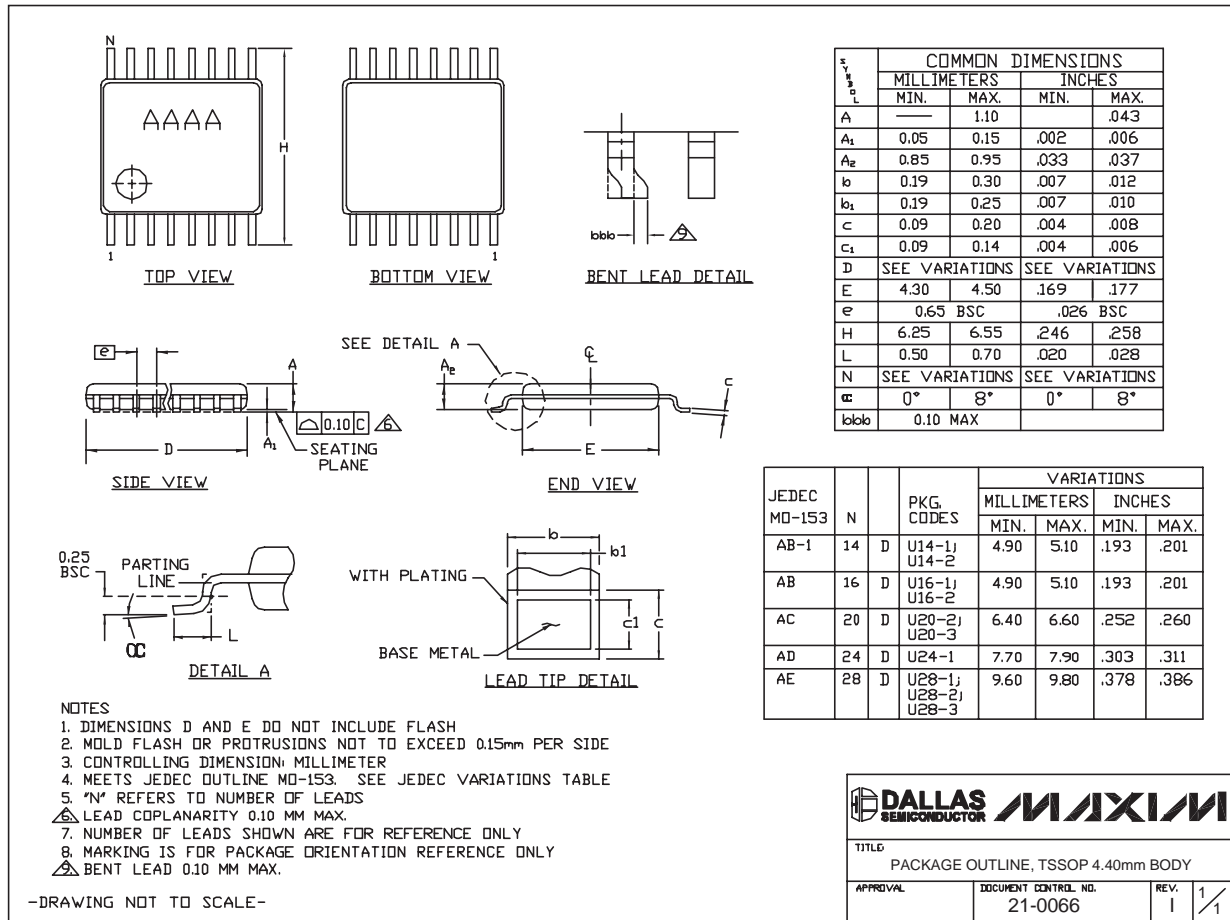



Note: The MAX1282/MAX1283 do not have an exposed die pad.

Maxim cannot assume responsibility for use of any circuitry other than circuitry entirely embodied in a Maxim product. No circuit patent licenses are implied. Maxim reserves the right to change the circuitry and specifications without notice at any time.

Maxim Integrated Products, 120 San Gabriel Drive, Sunnyvale, CA 94086 408-737-7600 23

Looking for pricing, stock, or lifecycle information?

Click below to explore more details on WIN SOURCE:

-  [View MAX1282BEUE+T on WIN SOURCE](#)
-  [Maxim Integrated Information](#)

Optimize Your Supply Chain with WIN SOURCE Solutions

-  Global Sourcing Solution
-  Obsolete Management
-  Cost Control Management
-  Shortage Management
-  Alternative Solution
-  Excess Inventory Management