



**THE DATASHEET OF
M74HC534B1R**





M74HC534

OCTAL D-TYPE FLIP FLOP WITH 3 STATE OUTPUT INVERTING

- HIGH SPEED:
 $f_{MAX} = 90\text{MHz}$ (TYP.) at $V_{CC} = 6\text{V}$
- LOW POWER DISSIPATION:
 $I_{CC} = 4\mu\text{A}$ (MAX.) at $T_A=25^\circ\text{C}$
- HIGH NOISE IMMUNITY:
 $V_{NIH} = V_{NIL} = 28\% V_{CC}$ (MIN.)
- SYMMETRICAL OUTPUT IMPEDANCE:
 $|I_{OH}| = I_{OL} = 6\text{mA}$ (MIN)
- BALANCED PROPAGATION DELAYS:
 $t_{PLH} \cong t_{PHL}$
- WIDE OPERATING VOLTAGE RANGE:
 V_{CC} (OPR) = 2V to 6V
- PIN AND FUNCTION COMPATIBLE WITH 74 SERIES 534

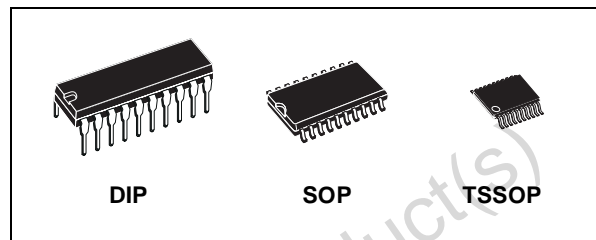

ORDER CODES

| PACKAGE | TUBE | T & R |
|---------|-------------|----------------|
| DIP | M74HC534B1R | |
| SOP | M74HC534M1R | M74HC534RM13TR |
| TSSOP | | M74HC534TTR |

DESCRIPTION

The M74HC534 is an high speed CMOS OCTAL D-TYPE FLIP FLOP WITH 3-STATE OUTPUTS INVERTING fabricated with silicon gate C²MOS technology.

This 8 bit D-TYPE FLIP FLOP is controlled by a clock input (CK) and an output enable input (\overline{OE}). On the positive transition of the clock, the Q outputs will be set to the logic state that were setup at the D inputs.

While the \overline{OE} input is at low level, the eight outputs will be in a normal logic state (high or low logic

level) and while high level the outputs will be in a high impedance state.

The output control does not affect the internal operation of flip-flops; that is, the old data can be retained or the new data can be entered even while the outputs are off.

All inputs are equipped with protection circuits against static discharge and transient excess voltage.

PIN CONNECTION AND IEC LOGIC SYMBOLS

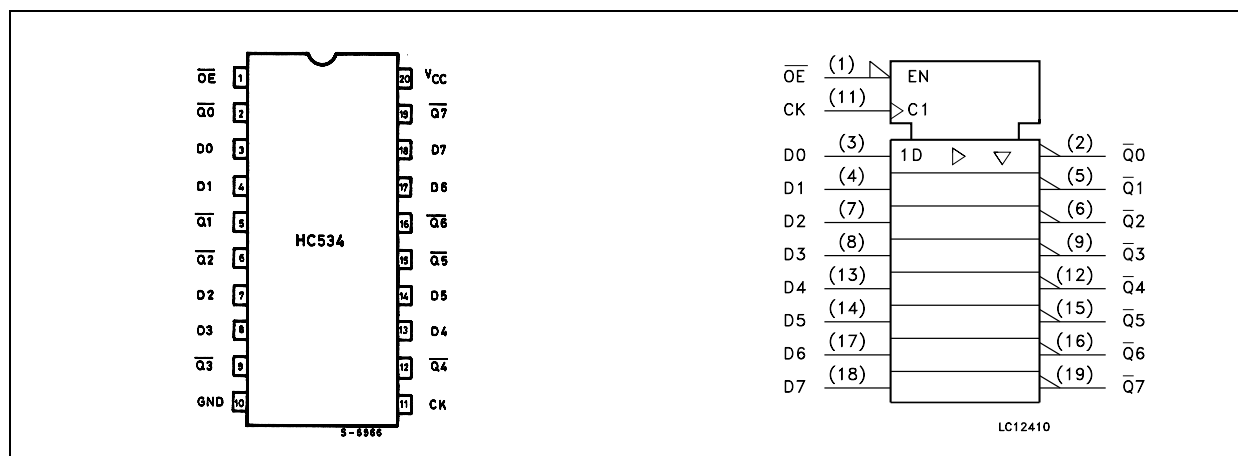

M74HC534

INPUT AND OUTPUT EQUIVALENT CIRCUIT

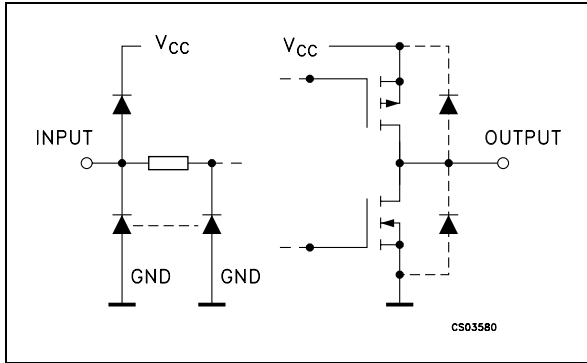

PIN DESCRIPTION

| PIN No | SYMBOL | NAME AND FUNCTION |
|----------------------------|-----------------|---|
| 1 | \overline{OE} | 3 State Output Enable Input (Active LOW) |
| 2, 5, 6, 9, 12, 15, 16, 19 | Q0 to Q7 | 3 State Outputs |
| 3, 4, 7, 8, 13, 14, 17, 18 | D0 to D7 | Data Inputs |
| 11 | CLOCK | Clock Input (LOW to HIGH, edge triggered) |
| 10 | GND | Ground (0V) |
| 20 | V _{CC} | Positive Supply Voltage |

TRUTH TABLE

| INPUTS | | | OUTPUT |
|-----------------|----|---|----------------|
| \overline{OE} | CK | D | \overline{Q} |
| H | X | X | Z |
| L | | X | NO CHANGE |
| L | | L | H |
| L | | H | L |

X: Don't Care
Z: High Impedance

LOGIC DIAGRAM

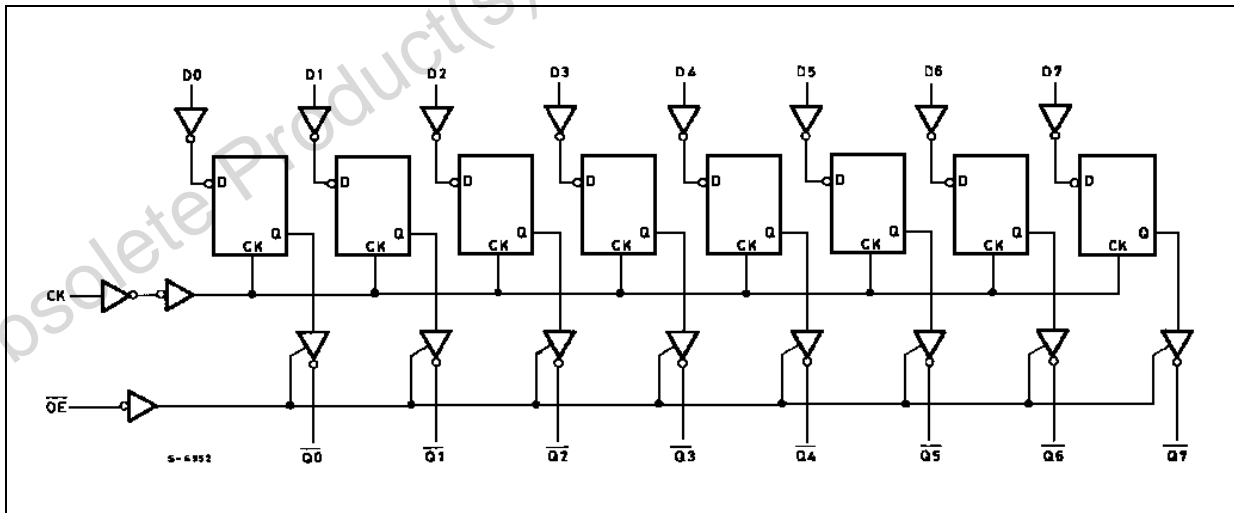

This logic diagram has not be used to estimate propagation delays

ABSOLUTE MAXIMUM RATINGS

| Symbol | Parameter | Value | Unit |
|-----------------------|-------------------------------|------------------------|------|
| V_{CC} | Supply Voltage | -0.5 to +7 | V |
| V_I | DC Input Voltage | -0.5 to $V_{CC} + 0.5$ | V |
| V_O | DC Output Voltage | -0.5 to $V_{CC} + 0.5$ | V |
| I_{IK} | DC Input Diode Current | ± 20 | mA |
| I_{OK} | DC Output Diode Current | ± 20 | mA |
| I_O | DC Output Current | ± 35 | mA |
| I_{CC} or I_{GND} | DC V_{CC} or Ground Current | ± 70 | mA |
| P_D | Power Dissipation | 500(*) | mW |
| T_{stg} | Storage Temperature | -65 to +150 | °C |
| T_L | Lead Temperature (10 sec) | 300 | °C |

Absolute Maximum Ratings are those values beyond which damage to the device may occur. Functional operation under these conditions is not implied

(*) 500mW at 65 °C; derate to 300mW by 10mW/°C from 65°C to 85°C

RECOMMENDED OPERATING CONDITIONS

| Symbol | Parameter | Value | Unit | |
|------------|--------------------------|-----------------|-----------|----|
| V_{CC} | Supply Voltage | 2 to 6 | V | |
| V_I | Input Voltage | 0 to V_{CC} | V | |
| V_O | Output Voltage | 0 to V_{CC} | V | |
| T_{op} | Operating Temperature | -55 to 125 | °C | |
| t_r, t_f | Input Rise and Fall Time | $V_{CC} = 2.0V$ | 0 to 1000 | ns |
| | | $V_{CC} = 4.5V$ | 0 to 500 | ns |
| | | $V_{CC} = 6.0V$ | 0 to 400 | ns |

DC SPECIFICATIONS

| Symbol | Parameter | Test Condition | | Value | | | | | | Unit | |
|-----------------|---------------------------------------|------------------------|--|-----------------------|------|-------|-------------|------|--------------|------|------|
| | | V _{CC} (V) | | T _A = 25°C | | | -40 to 85°C | | -55 to 125°C | | |
| | | | | Min. | Typ. | Max. | Min. | Max. | Min. | | Max. |
| V _{IH} | High Level Input Voltage | 2.0 | | 1.5 | | | 1.5 | | 1.5 | | V |
| | | 4.5 | | 3.15 | | | 3.15 | | 3.15 | | |
| | | 6.0 | | 4.2 | | | 4.2 | | 4.2 | | |
| V _{IL} | Low Level Input Voltage | 2.0 | | | | 0.5 | | 0.5 | | 0.5 | V |
| | | 4.5 | | | | 1.35 | | 1.35 | | 1.35 | |
| | | 6.0 | | | | 1.8 | | 1.8 | | 1.8 | |
| V _{OH} | High Level Output Voltage | 2.0 | I _O =-20 μA | 1.9 | 2.0 | | 1.9 | | 1.9 | | V |
| | | 4.5 | I _O =-20 μA | 4.4 | 4.5 | | 4.4 | | 4.4 | | |
| | | 6.0 | I _O =-20 μA | 5.9 | 6.0 | | 5.9 | | 5.9 | | |
| | | 4.5 | I _O =-6.0 mA | 4.18 | 4.31 | | 4.13 | | 4.10 | | |
| | | 6.0 | I _O =-7.8 mA | 5.68 | 5.8 | | 5.63 | | 5.60 | | |
| V _{OL} | Low Level Output Voltage | 2.0 | I _O =20 μA | | 0.0 | 0.1 | | 0.1 | | 0.1 | V |
| | | 4.5 | I _O =20 μA | | 0.0 | 0.1 | | 0.1 | | 0.1 | |
| | | 6.0 | I _O =20 μA | | 0.0 | 0.1 | | 0.1 | | 0.1 | |
| | | 4.5 | I _O =6.0 mA | | 0.17 | 0.26 | | 0.33 | | 0.40 | |
| | | 6.0 | I _O =7.8 mA | | 0.18 | 0.26 | | 0.33 | | 0.40 | |
| I _I | Input Leakage Current | 6.0 | V _I = V _{CC} or GND | | | ± 0.1 | | ± 1 | | ± 1 | μA |
| I _{OZ} | High Impedance Output Leakage Current | 6.0 | V _I = V _{IH} or V _{IL} V _O = V _{CC} or GND | | | ± 0.5 | | ± 5 | | ± 10 | μA |
| I _{CC} | Quiescent Supply Current | 6.0 | V _I = V _{CC} or GND | | | 4 | | 40 | | 80 | μA |

AC ELECTRICAL CHARACTERISTICS ($C_L = 50 \text{ pF}$, Input $t_r = t_f = 6 \text{ ns}$)

| Symbol | Parameter | Test Condition | | | Value | | | | | | Unit | |
|--------------------------|---|-----------------|---------------|---------------------------|--------------------------|------|------|------------------------------------|------|-------------------------------------|------|------|
| | | V_{CC} (V) | C_L (pF) | | $T_A = 25^\circ\text{C}$ | | | $-40 \text{ to } 85^\circ\text{C}$ | | $-55 \text{ to } 125^\circ\text{C}$ | | |
| | | | | | Min. | Typ. | Max. | Min. | Max. | Min. | | Max. |
| t_{TLH} t_{THL} | Output Transition Time | 2.0 | 50 | | | 25 | 60 | | 75 | | 90 | ns |
| | | 4.5 | | | 7 | 12 | | 15 | | 18 | | |
| | | 6.0 | | | 6 | 10 | | 13 | | 15 | | |
| t_{PLH} t_{PHL} | Propagation Delay Time (CK - \bar{Q}) | 2.0 | 50 | | 45 | 140 | | 175 | | 210 | ns | |
| | | 4.5 | | | 15 | 28 | | 35 | | 42 | | |
| | | 6.0 | | | 13 | 24 | | 30 | | 36 | | |
| | | 2.0 | 150 | | 60 | 190 | | 240 | | 285 | ns | |
| | | 4.5 | | | 20 | 38 | | 48 | | 57 | | |
| | | 6.0 | | | 17 | 32 | | 41 | | 48 | | |
| t_{PZL} t_{PZH} | High Impedance Output Enable Time | 2.0 | 50 | $R_L = 1 \text{ K}\Omega$ | | 39 | 135 | | 170 | | 205 | ns |
| | | 4.5 | | | | 13 | 27 | | 34 | | 41 | |
| | | 6.0 | | | | 11 | 23 | | 29 | | 35 | |
| | | 2.0 | 150 | $R_L = 1 \text{ K}\Omega$ | | 54 | 185 | | 230 | | 280 | ns |
| | | 4.5 | | | | 18 | 37 | | 46 | | 56 | |
| | | 6.0 | | | | 15 | 31 | | 39 | | 48 | |
| t_{PLZ} t_{PHZ} | High Impedance Output Disable Time | 2.0 | 50 | $R_L = 1 \text{ K}\Omega$ | | 30 | 125 | | 155 | | 190 | ns |
| | | 4.5 | | | | 14 | 25 | | 31 | | 38 | |
| | | 6.0 | | | | 13 | 21 | | 26 | | 32 | |
| f_{MAX} | Maximum Clock Frequency | 2.0 | 50 | | 6.2 | 18 | | 5 | | 4.2 | ns | |
| | | 4.5 | | | 31 | 75 | | 25 | | 21 | | |
| | | 6.0 | | | 37 | 90 | | 30 | | 25 | | |
| $t_{W(L)}$ $t_{W(H)}$ | Minimum Pulse Width (CK) | 2.0 | 50 | | | 15 | 75 | | 95 | | 110 | ns |
| | | 4.5 | | | 6 | 15 | | 19 | | 22 | | |
| | | 6.0 | | | 6 | 13 | | 16 | | 19 | | |
| t_s | Minimum Set-up Time | 2.0 | 50 | | | 25 | 75 | | 95 | | 110 | ns |
| | | 4.5 | | | 6 | 15 | | 19 | | 22 | | |
| | | 6.0 | | | 4 | 13 | | 16 | | 19 | | |
| t_h | Minimum Hold Time | 2.0 | 50 | | | | 0 | | 0 | | 0 | ns |
| | | 4.5 | | | | 0 | | 0 | | 0 | | |
| | | 6.0 | | | | 0 | | 0 | | 0 | | |

CAPACITIVE CHARACTERISTICS

| Symbol | Parameter | Test Condition | | | Value | | | | | | Unit | |
|-----------|--|-----------------|--|--|--------------------------|------|------|------------------------------------|------|-------------------------------------|------|------|
| | | V_{CC} (V) | | | $T_A = 25^\circ\text{C}$ | | | $-40 \text{ to } 85^\circ\text{C}$ | | $-55 \text{ to } 125^\circ\text{C}$ | | |
| | | | | | Min. | Typ. | Max. | Min. | Max. | Min. | | Max. |
| C_{IN} | Input Capacitance | | | | | 5 | 10 | | 10 | | 10 | pF |
| C_{OUT} | Output Capacitance | | | | | 10 | | | | | | pF |
| C_{PD} | Power Dissipation Capacitance (note 1) | | | | | 47 | | | | | | pF |

1) C_{PD} is defined as the value of the IC's internal equivalent capacitance which is calculated from the operating current consumption without load. (Refer to Test Circuit). Average operating current can be obtained by the following equation. $I_{CC(oper)} = C_{PD} \times V_{CC} \times f_{IN} + I_{CC}/8$ (per Flip Flop) and the C_{PD} when n pcs of Flip Flop operate, can be gained by the following equation: $C_{PD(TOTAL)} = 30 + 17 \times n$ (pF)

TEST CIRCUIT

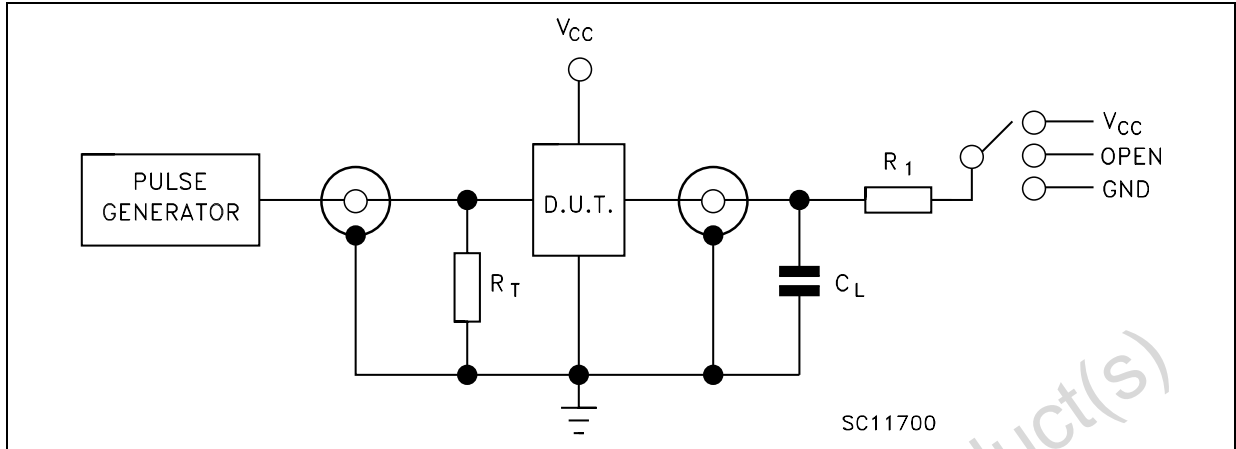

| TEST | SWITCH |
|-----------------------|----------|
| t_{PLH} , t_{PHL} | Open |
| t_{PZL} , t_{PLZ} | V_{CC} |
| t_{PZH} , t_{PHZ} | GND |

C_L = 50pF/150pF or equivalent (includes jig and probe capacitance)
 R_1 = 1K Ω or equivalent
 R_T = Z_{OUT} of pulse generator (typically 50 Ω)

WAVEFORM 1 : CK TO \overline{Qn} PROPAGATION DELAYS, Dn TO CK SETUP AND HOLD TIMES, MAXIMUM CK FREQUENCY ($f=1\text{MHz}$; 50% duty cycle)

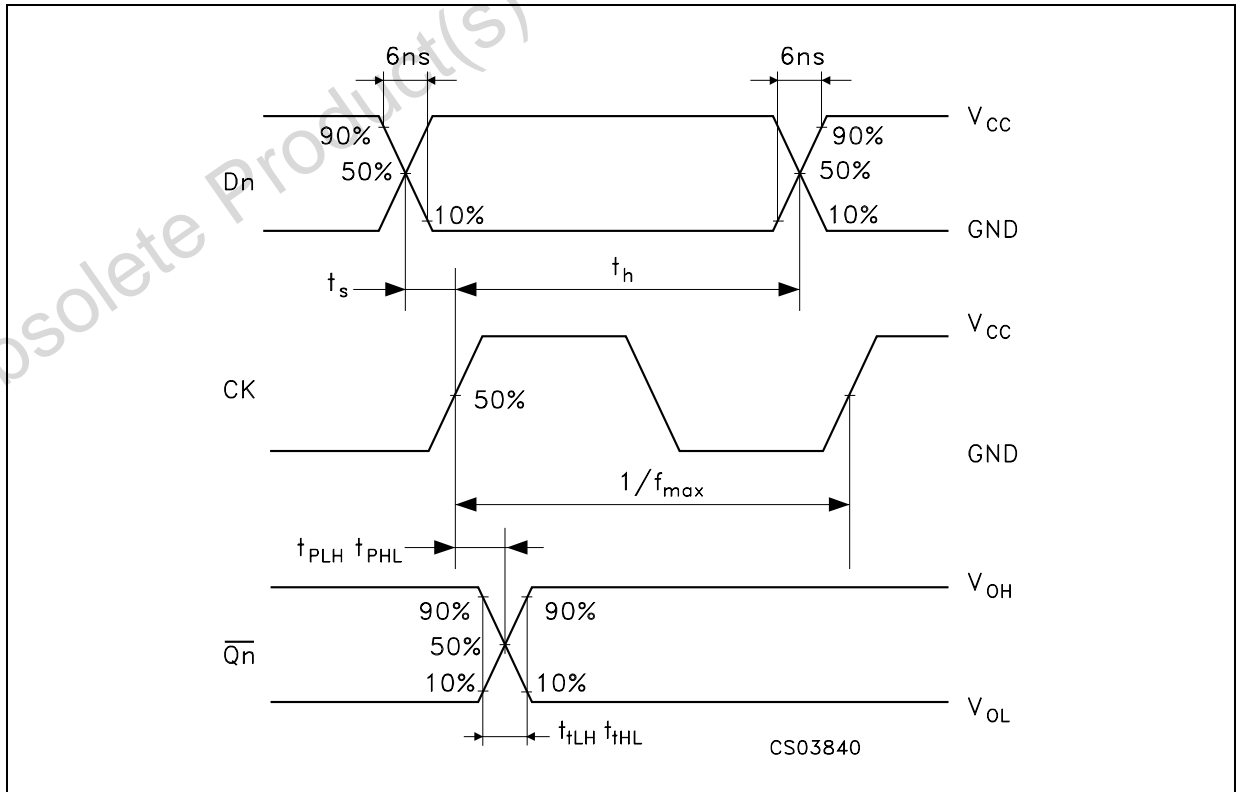

WAVEFORM 2 : OUTPUT ENABLE AND DISABLE TIMES (f=1MHz; 50% duty cycle)

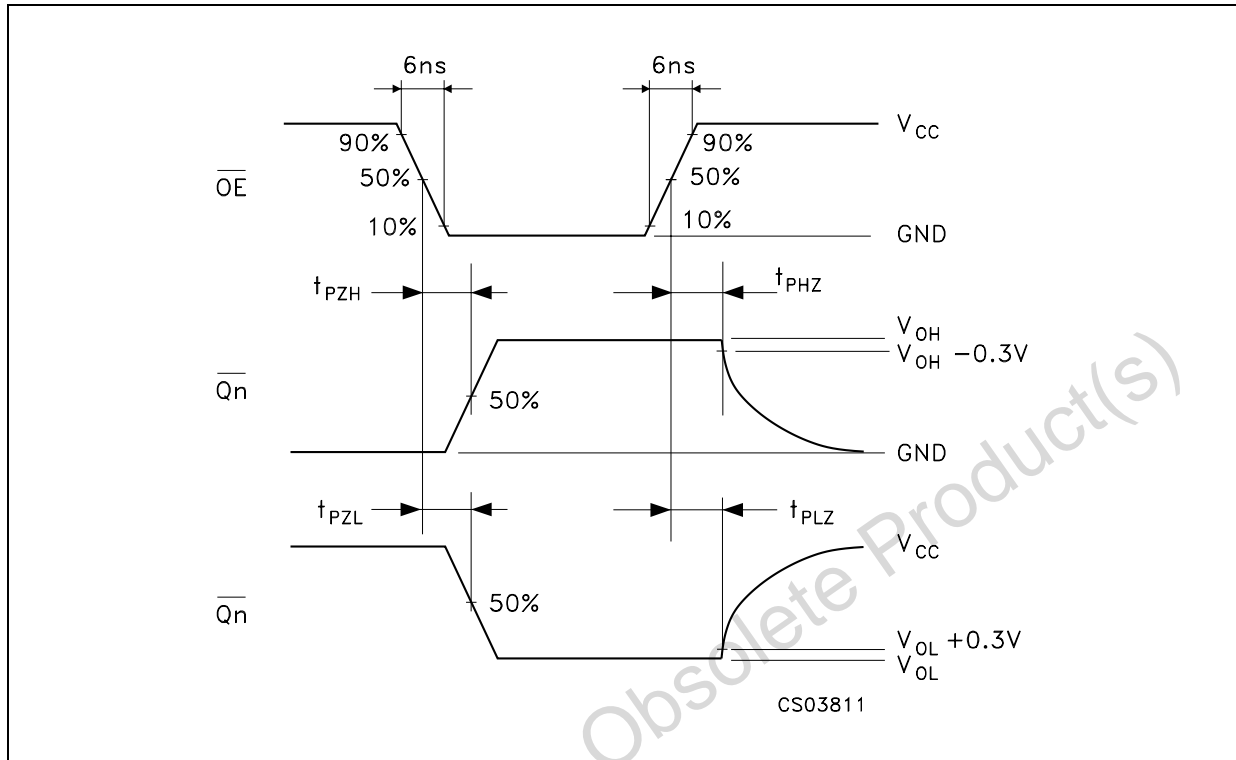

WAVEFORM 3 : CK MINIMUM PULSE WIDTH (f=1MHz; 50% duty cycle)

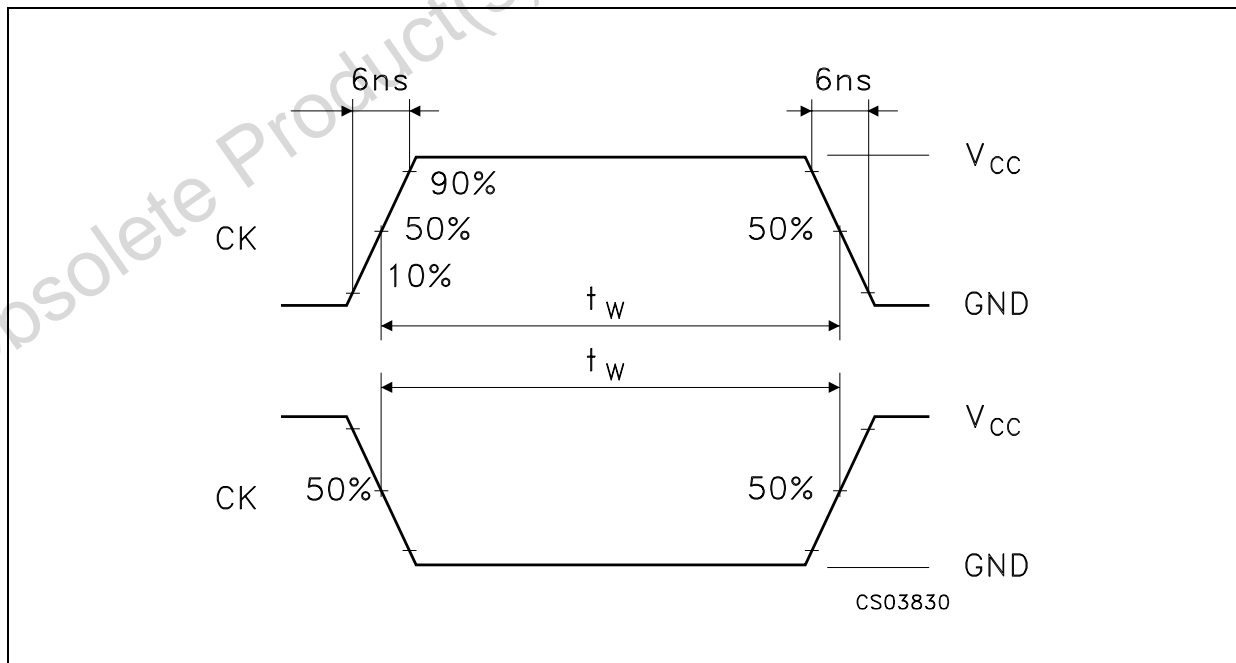

Plastic DIP-20 (0.25) MECHANICAL DATA

| DIM. | mm. | | | inch | | |
|------|-------|-------|------|-------|-------|-------|
| | MIN. | TYP | MAX. | MIN. | TYP. | MAX. |
| a1 | 0.254 | | | 0.010 | | |
| B | 1.39 | | 1.65 | 0.055 | | 0.065 |
| b | | 0.45 | | | 0.018 | |
| b1 | | 0.25 | | | 0.010 | |
| D | | | 25.4 | | | 1.000 |
| E | | 8.5 | | | 0.335 | |
| e | | 2.54 | | | 0.100 | |
| e3 | | 22.86 | | | 0.900 | |
| F | | | 7.1 | | | 0.280 |
| I | | | 3.93 | | | 0.155 |
| L | | 3.3 | | | 0.130 | |
| Z | | | 1.34 | | | 0.053 |

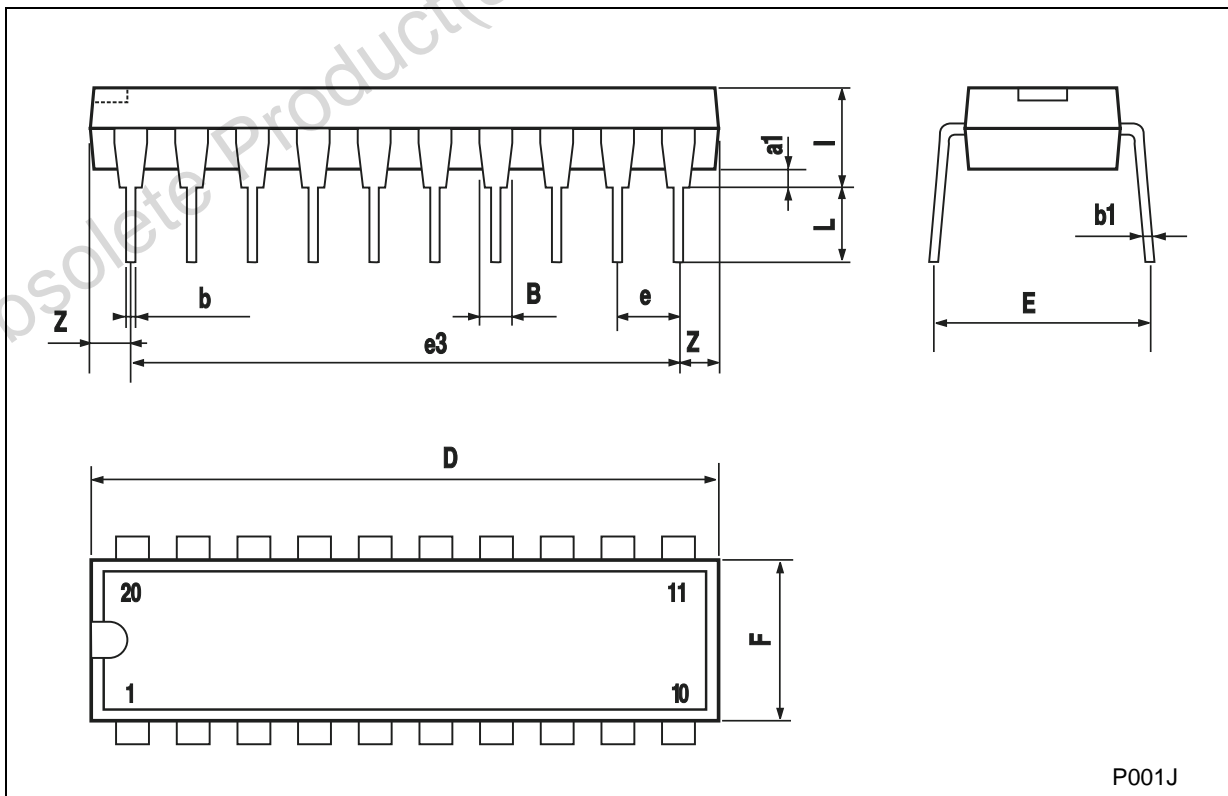

P001J

SO-20 MECHANICAL DATA

| DIM. | mm. | | | inch | | |
|------|------------|-------|-------|-------|-------|-------|
| | MIN. | TYP. | MAX. | MIN. | TYP. | MAX. |
| A | | | 2.65 | | | 0.104 |
| a1 | 0.1 | | 0.2 | 0.004 | | 0.008 |
| a2 | | | 2.45 | | | 0.096 |
| b | 0.35 | | 0.49 | 0.014 | | 0.019 |
| b1 | 0.23 | | 0.32 | 0.009 | | 0.012 |
| C | | 0.5 | | | 0.020 | |
| c1 | 45° (typ.) | | | | | |
| D | 12.60 | | 13.00 | 0.496 | | 0.512 |
| E | 10.00 | | 10.65 | 0.393 | | 0.419 |
| e | | 1.27 | | | 0.050 | |
| e3 | | 11.43 | | | 0.450 | |
| F | 7.40 | | 7.60 | 0.291 | | 0.300 |
| L | 0.50 | | 1.27 | 0.020 | | 0.050 |
| M | | | 0.75 | | | 0.029 |
| S | 8° (max.) | | | | | |

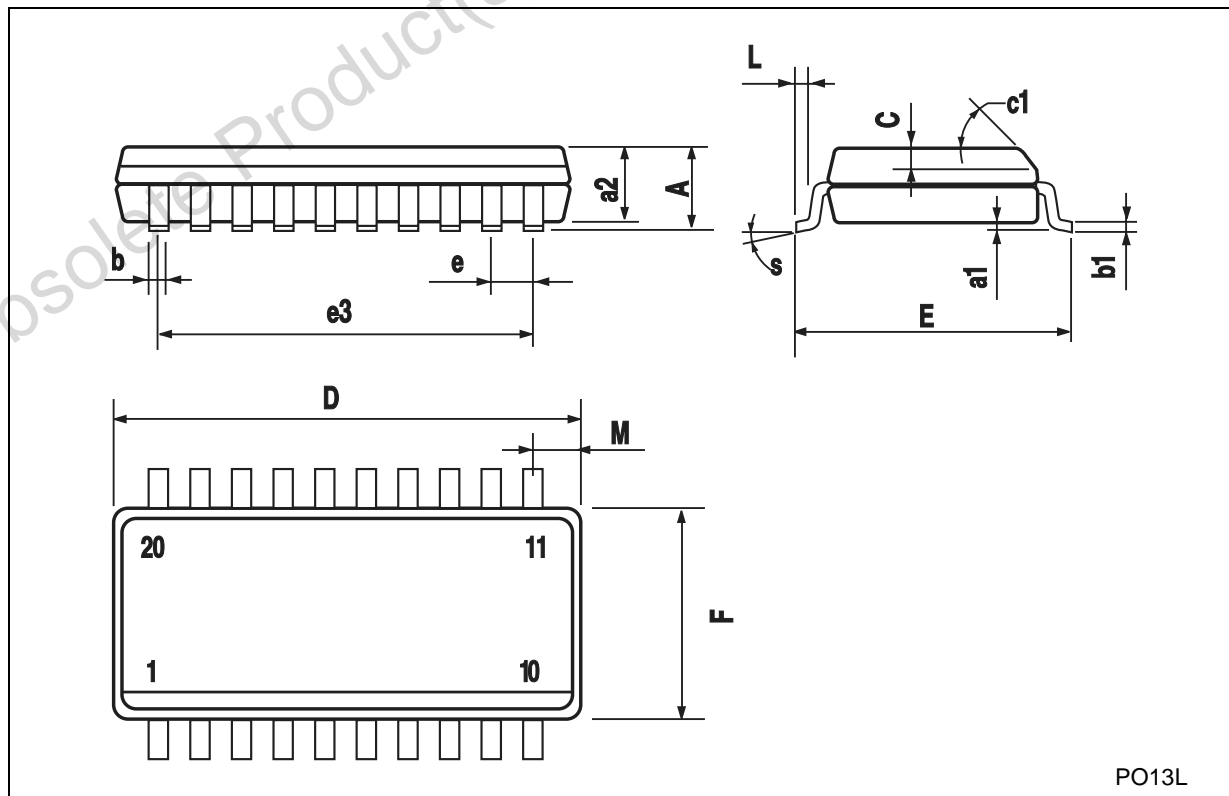

PO13L

TSSOP20 MECHANICAL DATA

| DIM. | mm. | | | inch | | |
|------|------|----------|------|-------|------------|--------|
| | MIN. | TYP | MAX. | MIN. | TYP. | MAX. |
| A | | | 1.2 | | | 0.047 |
| A1 | 0.05 | | 0.15 | 0.002 | 0.004 | 0.006 |
| A2 | 0.8 | 1 | 1.05 | 0.031 | 0.039 | 0.041 |
| b | 0.19 | | 0.30 | 0.007 | | 0.012 |
| c | 0.09 | | 0.20 | 0.004 | | 0.0089 |
| D | 6.4 | 6.5 | 6.6 | 0.252 | 0.256 | 0.260 |
| E | 6.2 | 6.4 | 6.6 | 0.244 | 0.252 | 0.260 |
| E1 | 4.3 | 4.4 | 4.48 | 0.169 | 0.173 | 0.176 |
| e | | 0.65 BSC | | | 0.0256 BSC | |
| K | 0° | | 8° | 0° | | 8° |
| L | 0.45 | 0.60 | 0.75 | 0.018 | 0.024 | 0.030 |

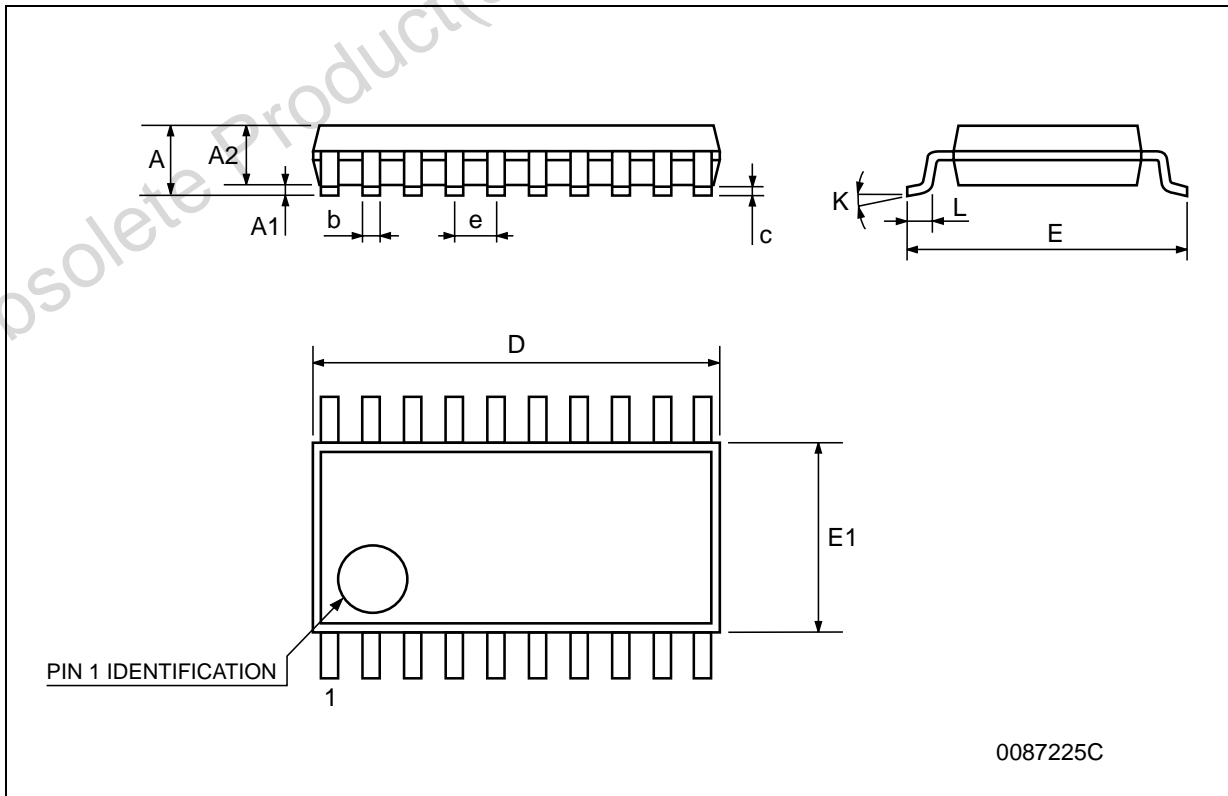

Obsolete Product(s) - Obsolete Product(s)

Information furnished is believed to be accurate and reliable. However, STMicroelectronics assumes no responsibility for the consequences of use of such information nor for any infringement of patents or other rights of third parties which may result from its use. No license is granted by implication or otherwise under any patent or patent rights of STMicroelectronics. Specifications mentioned in this publication are subject to change without notice. This publication supersedes and replaces all information previously supplied. STMicroelectronics products are not authorized for use as critical components in life support devices or systems without express written approval of STMicroelectronics.

© The ST logo is a registered trademark of STMicroelectronics

© 2000 STMicroelectronics - Printed in Italy - All Rights Reserved
STMicroelectronics GROUP OF COMPANIES



Australia - Brazil - China - Finland - France - Germany - Hong Kong - India - Italy - Japan - Malaysia - Malta - Morocco
Singapore - Spain - Sweden - Switzerland - United Kingdom

© <http://www.st.com>



Looking for pricing, stock, or lifecycle information?

Click below to explore more details on WIN SOURCE:

-  [View M74HC534B1R](#) on WIN SOURCE
-  [STMicroelectronics](#) Information

Optimize Your Supply Chain with WIN SOURCE Solutions

-  Global Sourcing Solution
-  Obsolete Management
-  Cost Control Management
-  Shortage Management
-  Alternative Solution
-  Excess Inventory Management