

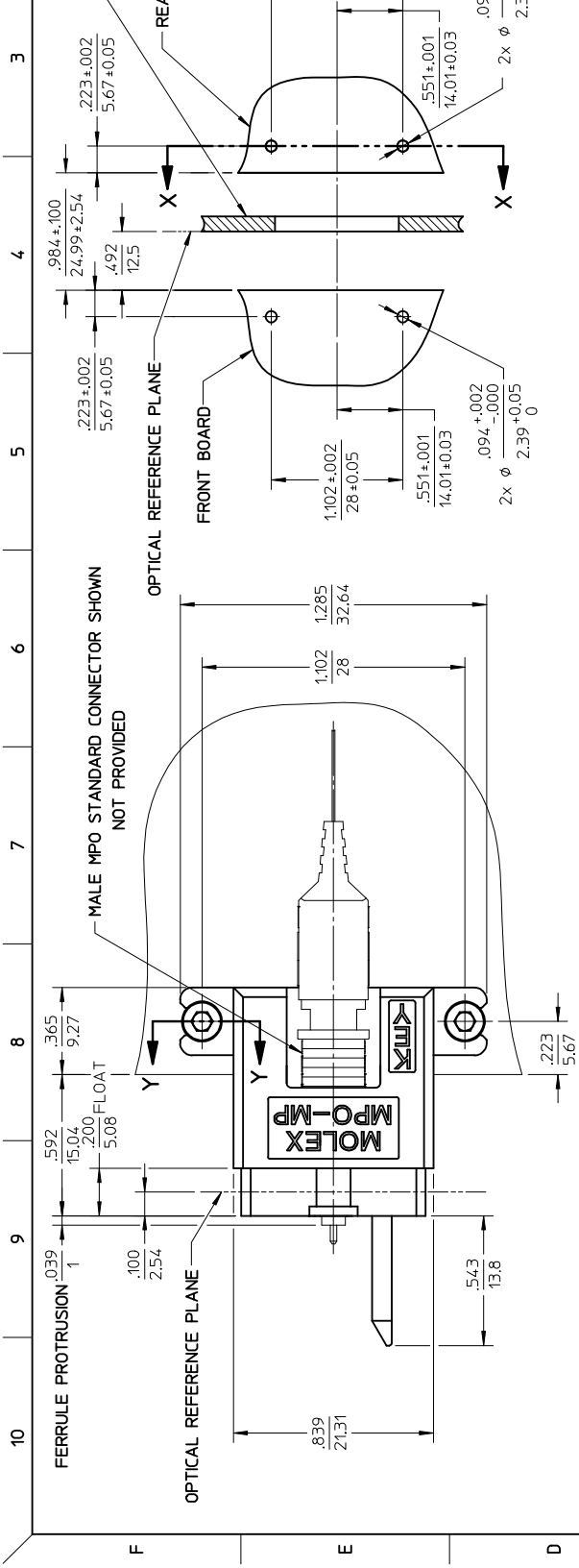

THE DATASHEET OF
1060880200





RECOMMENDED MOUNT
SCALE 1:1

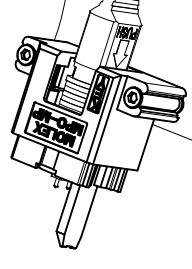

ISO VIEW 1
SCALE 1:1

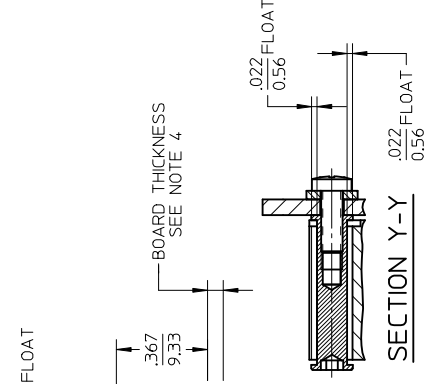

SECTION Y-Y
.022 FLOAT
0.56

- NOTES:
1. ALL DIMENSIONS ARE GIVEN IN INCHES/MM.
 2. BOARD THICKNESS FROM .063" TO .094"/1.6mm TO 2.4mm.
 3. TWO SCREWS ARE INSTALLED BY USER.
RECOMMENDED TORQUE: 2.5 TO 4 INCHLBS (0.28 TO 0.45 N.m).
DEPENDENT ON SUBSTRATE MATERIAL.
 4. USER IS RESPONSIBLE TO DETERMINE THE PROPER TORQUE.
MIDPLANE, FRONT BOARD AND REAR TRANSITION MODULE (RTM) SHOULD HAVE ALIGNMENT AND KEYING ACCORDING TO ATCA REQUIREMENTS.
 5. NO OPTICAL CONNECTIONS SHALL BE MADE UNTIL MIDPLANE (BACKPLANE) ALIGNMENT PINS CONNECTED WITH FEMALE RECEPTACLES OF THE FRONT BOARD AND REAR TRANSITION MODULE (RTM).

ENTER DESCRIPTION		QUALITY SYMBOLS		GENERAL TOLERANCES (UNLESS SPECIFIED)		DIMENSION STYLE	
REV	DESCRIPTION	SYMBOL	TOLERANCE	IN/CH	IN/CH	TITLE	DATE
A	DRWN:BELENKIY 2005/10/25 CHK'D: 2005/10/25 APP'R:IMAKHLIN 2005/10/25	▶=0	±	4 PLACES	±	DRAWN BY	YB 10.13.05
		▽=0	±	3 PLACES	±	CHECKED BY	SM 10.13.05
			±	2 PLACES	±	APPROVED BY	IM 10.13.05
			±	1 PLACE	±	MATERIAL NO.	1060880200
			±	ANGULAR	±---°	DOC	1060880200
				DRAFT WHERE APPLICABLE MUST REMAIN WITHIN DIMENSIONS			
				SIZE B THIS DRAWING CONTAINS INCORPORATED AND SHC			

Looking for pricing, stock, or lifecycle information?

Click below to explore more details on WIN SOURCE:

 [View 1060880200 on WIN SOURCE](#)

 [Molex, LLC Information](#)

Optimize Your Supply Chain with WIN SOURCE Solutions

-  Global Sourcing Solution
-  Obsolete Management
-  Cost Control Management
-  Shortage Management
-  Alternative Solution
-  Excess Inventory Management