



**THE DATASHEET OF
AUIR3200STR**



MOSFET DRIVER WITH PROTECTION AND DIAGNOSTIC

Features

- Bootstrap and charge pump
- Over temperature shutdown (with Ptc interface)
- Short circuit protection (Vds detection)
- Reverse battery protection (turns On the MOSFET)
- Ground loss protection
- Diagnostic
- ESD protection

Product Summary

Operating voltage 6-36V
Vgate 6V

Description

The AUIR3200S is a high side mosfet driver for very low Rdson automotive application. It offers over-current, over-temperature protection and diagnostic. The over-current protection is done by monitoring the Vds voltage, the threshold is programmable by external resistor. The over-temperature protection uses a thermal sensor. The AUIR3200S offers diagnostic on the input pin.

Package

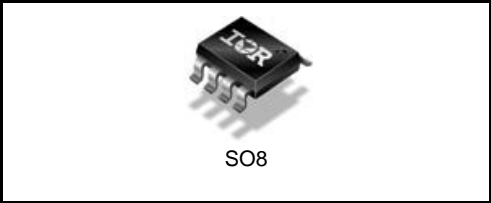

Ordering Information

Base Part Number	Package Type	Standard Pack		Complete Part Number
		Form	Quantity	
AUIR3200S	SOIC-8 leads	Tape and Reel	2500	AUIR3200STR

Typical Connection

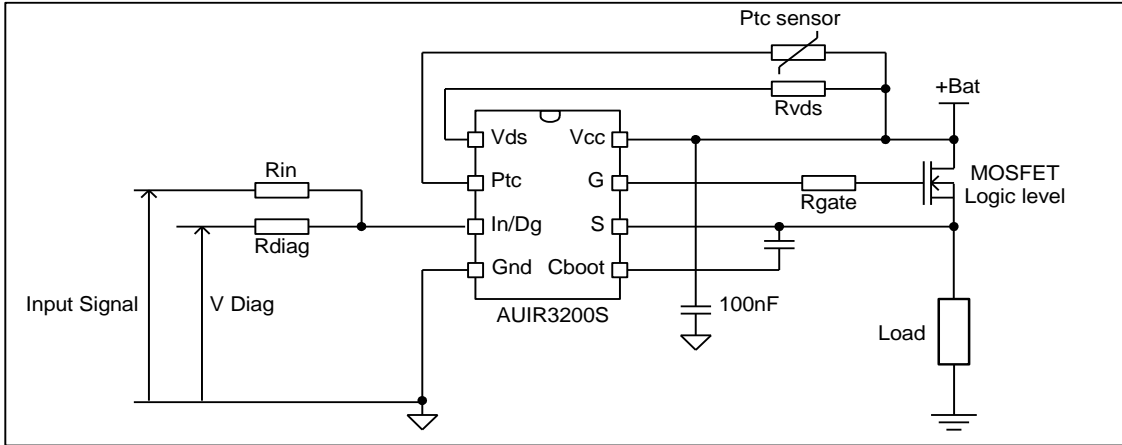

Absolute Maximum Ratings

Absolute maximum ratings indicate sustained limits beyond which damage to the device may occur. All voltage parameters are referenced to Ground lead. (T_j= -40°C..150°C unless otherwise specified).

Symbol	Parameter	Min.	Max.	Units
V _{cc-gnd}	Maximum V _{cc} voltage	-0.3	60	V
V _{cc-Vds}	Maximum V _{ds} pin voltage	-0.3	5.5	
V _{cc-Vptc}	Maximum P _{tc} pin voltage	-0.3	5.5	
V _{in-gnd}	Maximum I _N pin voltage	-0.3	5.5	
V _{cc-Vs}	Maximum S pin voltage	-0.3	60	
V _{cboot-Vs}	Maximum C _{boot} pin voltage	-0.3	8	
V _{cc cont.}	Maximum continuous V _{cc} voltage	—	36	
T _{j max.}	Maximum operating junction temperature	-40	150	°C
	Maximum storage temperature	-55	150	
T _{soldering}	Soldering temperature (10 seconds)	—	300	

Thermal Characteristics

Symbol	Parameter	Typ.	Max.	Units
R _{th}	Thermal resistance junction to ambient	100	—	°C/W

Recommended Operating Conditions

Symbol	Parameter	Min.	Max.	Units
V _{IH}	High level input voltage	2.7	5.5	V
V _{IL}	Low level input voltage	0	0.9	
R _{in}	Recommended resistor in series with I _N pin	10	15	kΩ
R _{diag}	Recommended resistor in series with Diag pin	4	15	
R _{vds}	Maximum recommended R _{vds} , see page 7	—	2.9	

Static Electrical Characteristics

T_j=-40°C..125°C, V_{cc}=6-36V (unless otherwise specified), typical value are given for V_{cc}=14V and T_j=25°C.

Symbol	Parameter	Min.	Typ.	Max.	Units	Test Conditions
V _{cc op.}	Operating voltage range	6	—	36	V	
I _{cc Off}	Supply current in sleep mode T _j =25°C	—	1	5	μA	V _{cc} =14V, V _{in} =0V
I _{cc On}	Supply current when On	—	10	15	mA	V _{in} =5V, V _{ptc} =V _{bat} , V _{ds} =V _{bat}
V _{IH}	IN High threshold voltage	—	2	2.6	V	
V _{IL}	IN Low threshold voltage	0.5	1.7	2.1		
I _{n hyst.}	Input hysteresis	0.2	0.5	1		
I _{in on}	On state input current	—	33	50	μA	V _{in} =5V
V _{gs}	Gate output voltage	5	5.7	7	V	I _{gs} =0μA
V _{gs rev}	Gate output voltage during reverse battery T _j =25°C	4.5	5.6	7		I _{gs} =50μA, V _{bat} =14V
V _{in, off}	Input voltage when the part is in fault mode	—	0.25	0.4		I _{dg} =300μA

Protection Characteristics

T_j=-40°C..125°C, V_{cc}=6-36V (unless otherwise specified), typical value are given for V_{cc}=14V and T_j=25°C.

Symbol	Parameter	Min.	Typ.	Max.	Units	Test Conditions
I _{vds}	V _{ds} current reference	0.7	0.8	0.91	mA	V _{cc} -V _{ds} =0V, T _j =-40°C
		0.84	0.93	1.05		V _{cc} -V _{ds} =0V, T _j =25°C
		1	1.15	1.33		V _{cc} -V _{ds} =0V, T _j =125°C
V _{ds offset}	V _{ds} comparator offset	-10	0	10	mV	
T _{blank on}	V _{ds} detection blanking time during turn on	15	22	35	μs	
T _{diag}	Diagnostic time	—	10	—	ms	see figure 6
T _{sleep}	Time to enter in sleep mode	7	15	30		
T _{reset}	Time to enter in sleep mode and reset the fault	—	5	—		
T _{wkp}	Time to leave the sleep mode	—	—	0.5	μs	R _{in} =10k see figure 7 & 8
T _{pwr on rst}	Power on reset duration T _j =25°C	40	100	200		
UV	Under voltage threshold	—	5.2	5.9	V	
T _{UV hold}	Time to keep UV detection active	150	350	600	μs	
P _{tc_sensor}	Ptc sensor threshold value when over temperature	1.3	5	14.3	kΩ	see page 2 & 8
R _{ptc}	Pull down resistor on the PTC pin	4	10	20		Built-in resistor See page 6
V _{ptc}	PTC comparator voltage threshold (V _{cc} -V _{ptc})	1.5	2	2.5	V	V _{in} =5V, V _{cc} =14V

Switching Characteristics

T_j=-40..125°C, V_{cc}=6..36V (unless otherwise specified), typical value are given for V_{cc}=14V and T_j=25°C.

Symbol	Parameter	Min.	Typ.	Max.	Units	Test Conditions
T _{don}	Turn-on delay to 20% of V _{gs}	—	1.6	—	μs	Q _g =220nc, R _{gate} =0Ω
T _r	Rise time 20% to 80% of V _{gs}	—	1	—		
T _{doff}	Turn off delay time to 80% of V _{gs}	—	2	—		
T _f	Fall time from 80% to 20% of V _{gs}	—	1	—		
I _{gs+}	Gate output high pulsed current	100	160	—	mA	V _{gs} =0V
I _{gs-}	Gate output low pulsed current	100	130	—		V _{gs} =5.7V
I _{boot}	Cboot capacitor charge current	0.35	0.8	—	A	
V _{boot-Source}	Cboot capacitor charge voltage	5.6	6	—	V	

True Table

Operating Conditions	IN	OUT	DG
Normal ON	H	H	H
Normal OFF	L	L	L
Short circuit to Gnd	H	L	L
Short circuit to Gnd	L	L	L
Over-temperature	H	L	L
Over-temperature	L	L	L

Lead Assignments

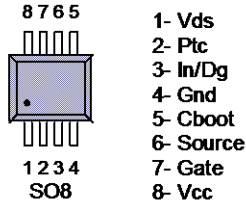

Functional Block Diagram

All values are typical

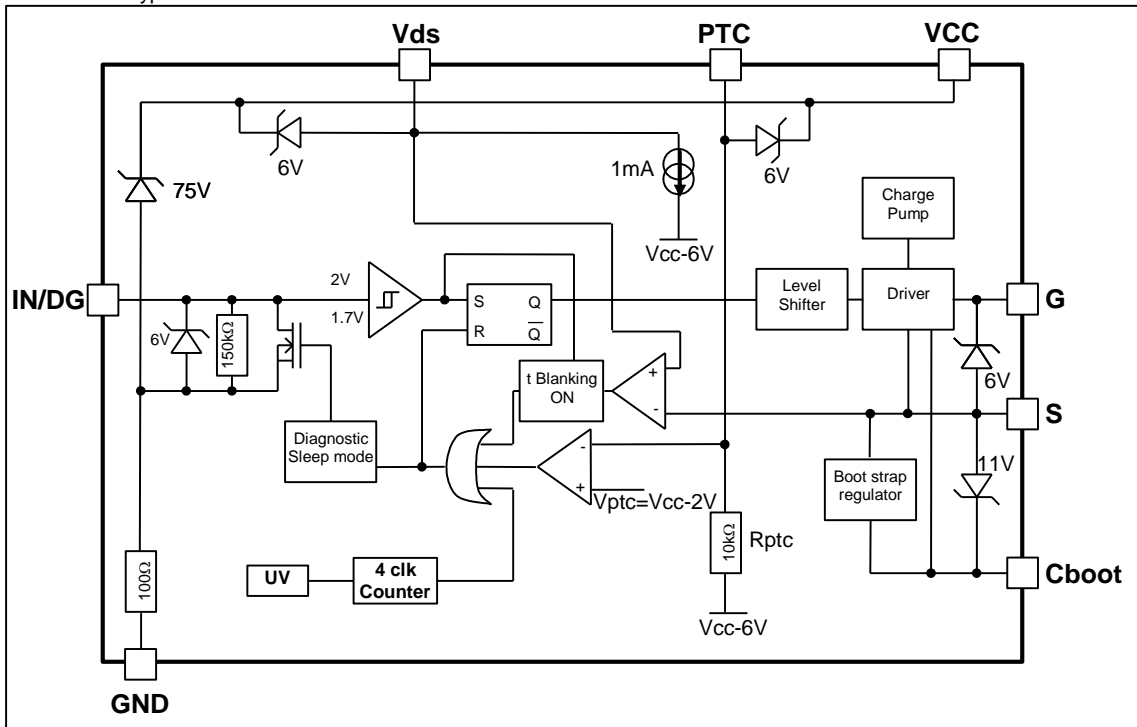

Over-current protection

The over-current protection is done by monitoring the Vds voltage of the Mosfet.
 The threshold is adjusted by connecting the appropriate resistor between Vcc and Vds pin => Rvds.
 Below the formula to set the appropriate over-current threshold:

$$I_{sd_threshold} = \frac{I_{vds} \times R_{vds}}{R_{dsOn}}$$

We advise to you to take low tolerance resistor for Rvds for optimize the precision of your current level protection.
 The AUIR3200S doesn't have feedback of the Mosfet temperature. We take in the consideration that Tcase of AUIR3200S will be almost the same like the Tcase of Mosfet. The current Ivds has a positive temperature coefficient to compensate the positive temperature coefficient of the RdsOn of the Mosfet.
 The above formula is only valid when the Mosfet is fully ON. Therefore during the turn on of the MOSFET, the time 'Tblank on' disables the vds protection until the Mosfet is fully On.
 Therefore a maximum resistor is specified for Rvds in the recommended section. With a higher resistor, the part will latch.

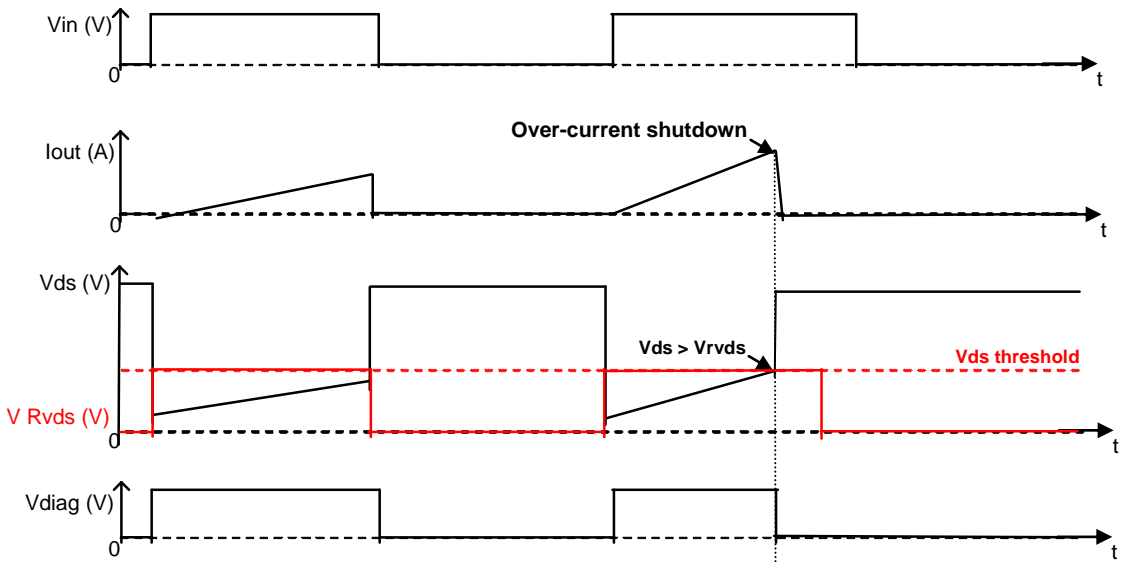

Figure 1: Protection Vds

Over-temperature protection

The temperature protection uses a PTC sensor connected to the tab or the drain of the Mosfet depending on the mounting. This sensor will increase with the temperature. When his value is above 5kΩ (typical value) the protection will be activated.

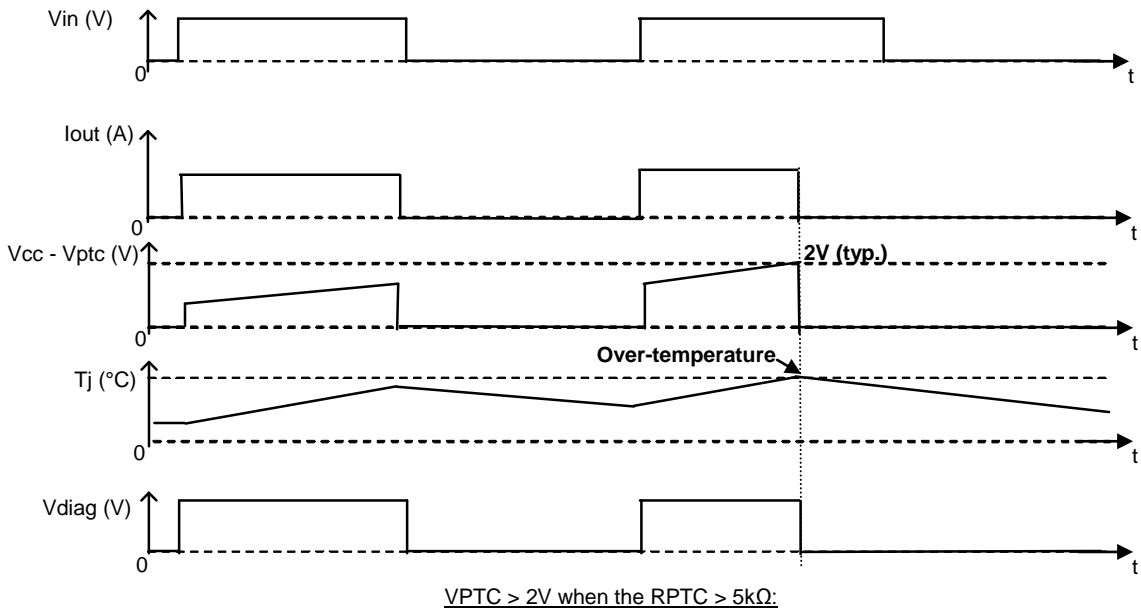

Figure 2: Protection PTC

For optimize the precision of the protection it is important to maximize the thermal interface between the sensor and the junction. The PTC sensor needs to be placed the closest possible of the MOSFET and to be surrounded by copper. The connection with AUIR3200S could be doing by a trace in bottom side of the PCB.

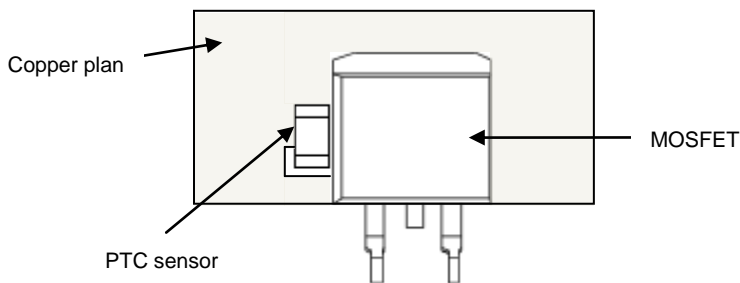

Figure 3: Layout example (top side)

The PTC protection could be activated if PTC sensor is higher than $1.3\text{k}\Omega$ (see page 4: 'Ptc sensor' characteristic).

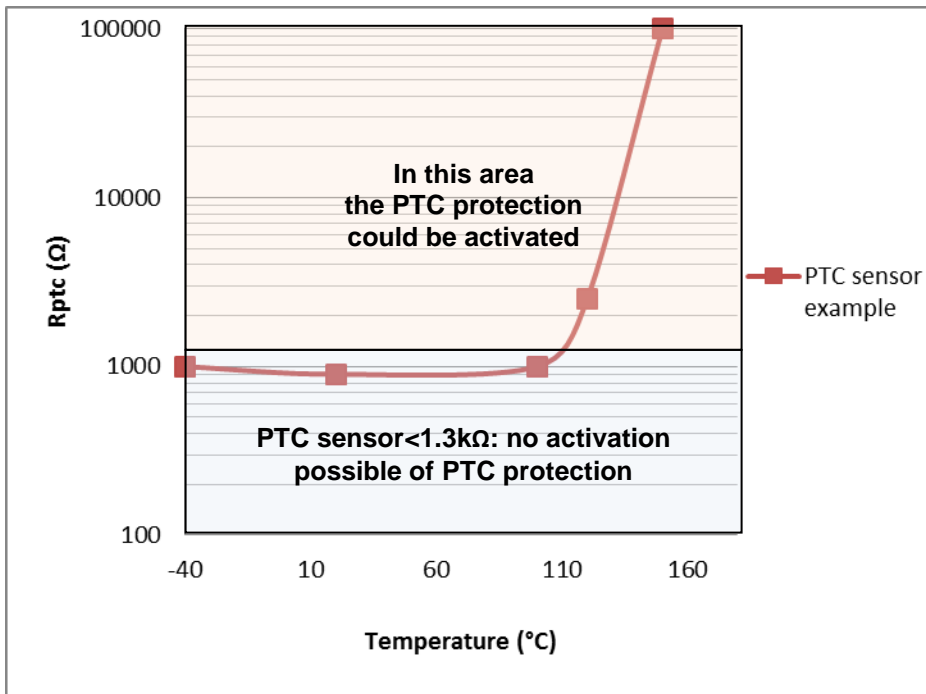

Figure 4: Typical PTC curve (R_{ptc} vs Temperature)

Protection evaluation

The PTC sensor, the V_{ds} threshold and the Mosfet must be chosen in order to not exceed the maximum junction temperature of the Mosfet during a short circuit.

Protection is evaluated by switching the Mosfet on different currents and by evaluating the junction temperature when the Mosfet is switched off by the protections.

This evaluation gives the following drawing.

- For high impedance short circuit, V_{ds} is smaller than V_{ds} threshold, so the over-temperature will act.
- For low impedance short circuit, the V_{ds} protection will switch off the Mosfet.

At the transition current between the 2 protections the junction temperature of the Mosfet is the maximum and should be lower than the maximum rating.

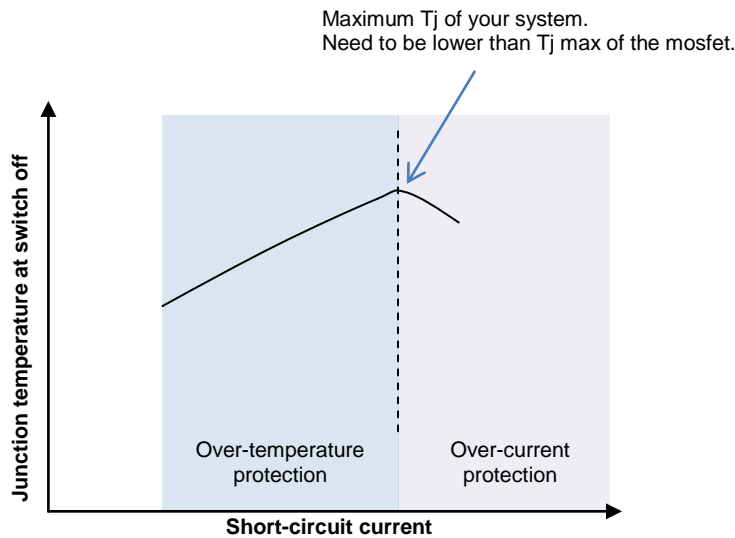

Figure 5: Protection evaluation

Sleep_mode / Diagnostic

Sleep_mode block manages the diagnostic and the sleep_mode. The device enters in sleep mode if input is inactive during a delay higher than T_{sleep} .

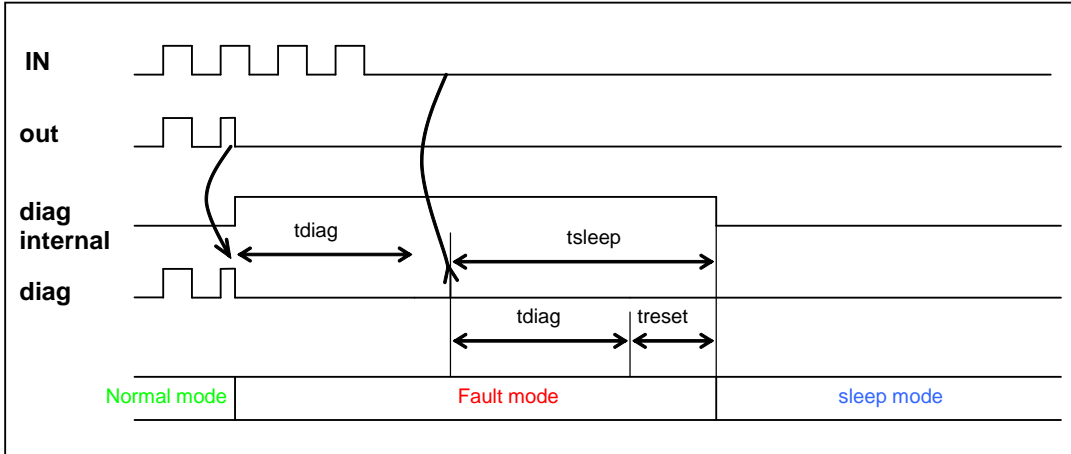

Figure 6

Wake up sequence

To wake up the part from the sleep mode, the input must be activated at least during T_{wkp} , then the bootstrap regulator is switched on and the bootstrap capacitor is charged. The output will not be activated during T_{pw} on rst.

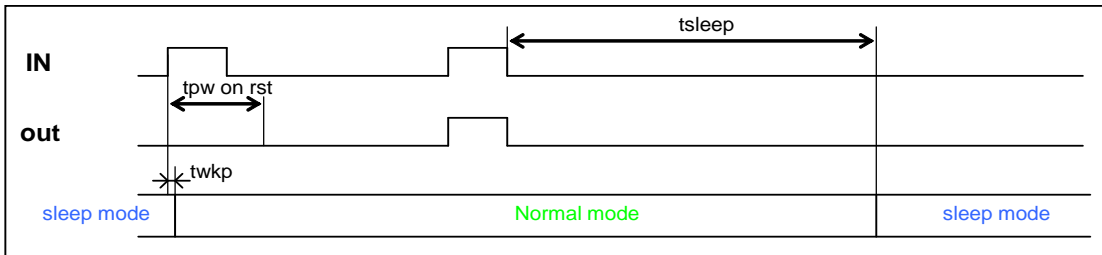

Figure 7

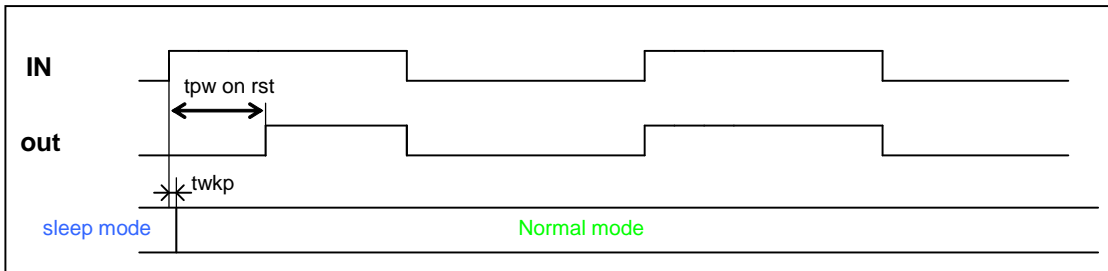

Figure 8

Bootstrap

The bootstrap capacitor provides the necessary current to the driver in order to charge the gate mosfet capacitor to the right voltage level.

A design rule to select the bootstrap capacitor value is to choose 10 times the gate capacitance.

You can find in the Mosfet datasheet 'Qg max' for a specific Vgs.

Below the formula to set the appropriate Cboot value:

$$C_{boot} = 10 \times \frac{Q_{g \max}}{V_{gs}}$$

The AUIR3200S integrates a bootstrap regulator to maintain a fixed voltage (Vboot=6V) on the bootstrap capacitor for any battery voltage.

The regulator is off during the sleep mode to reduce the current consumption.

The power on reset is necessary to charge the bootstrap capacitor before turns on the power mosfet. The bootstrap capacitor gets its charge through the load. So the time to charge it depends of the load.

But the power on reset doesn't monitor the bootstrap capacitor voltage. Its time is set internally to allow starting the most of load without implement a special sequence:

The power on reset is long enough to charge the bootstrap capacitor before turns on the power mosfet.

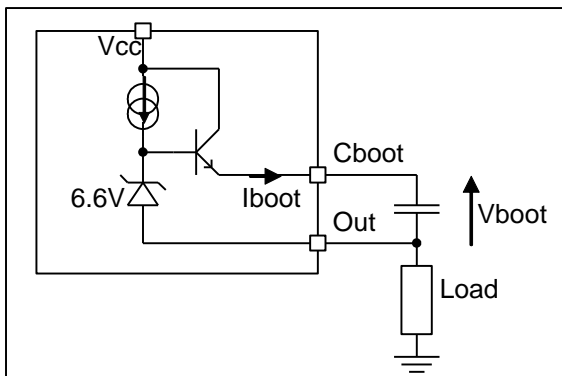

Figure 9

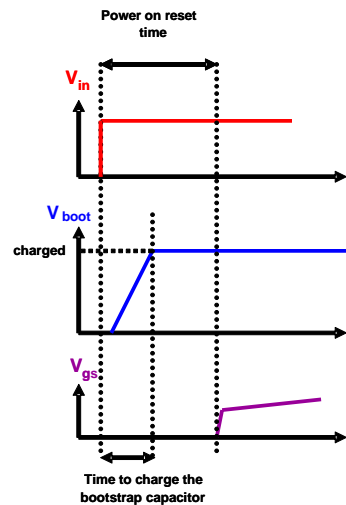

Figure 10

If the inductance of the load is too important, the power on reset is not enough long to charge completely the bootstrap capacitor before turns on the power mosfet.

So the micro-processor need to implement a special sequence to start the device without activates the output power mosfet.

The micro-processor send one short pulse ($T_{wkp} \max < \text{short pulse} < T_{pwr_on_rst} \min$) then wait for the bootstrap capacitor is totally charged and after provide the appropriate duty cycle.

The bootstrap charge depends of the battery voltage, the bootstrap capacitor value and the inductance load value.

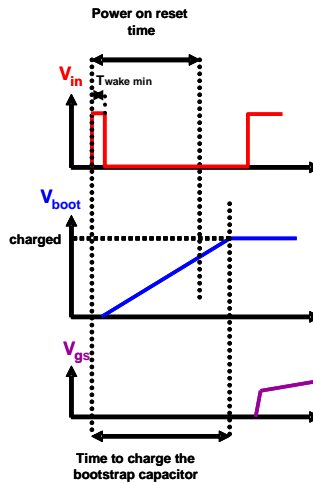

Figure 11

IN frequency and duty cycle

The Vds protection is not active if the time ON is lower than Tblank on.
 So the minimum time ON (ton) is 'Tblank on max' to be sure that this protection will be active.

The times OFF (toff) needs to be setup for assure that the capacitor bootstrap will be recharged up to 6V. The bootstrap time charge depends of the bootstrap capacitor value and the inductance load value.

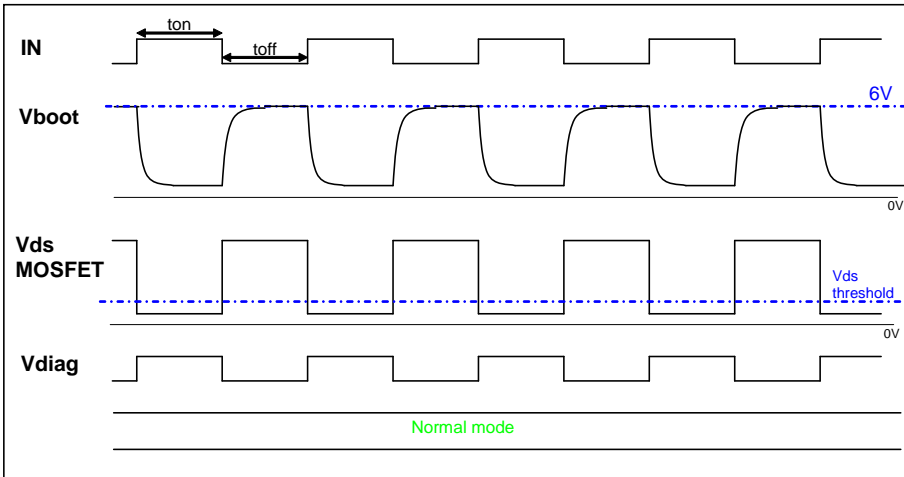

Figure 12

If the capacitor is discharged at the turn ON of the MOSFET, the AUIR3200S will detect a fault (VDS protection) after Tblank ON because the MOSFET won't be fully ON.

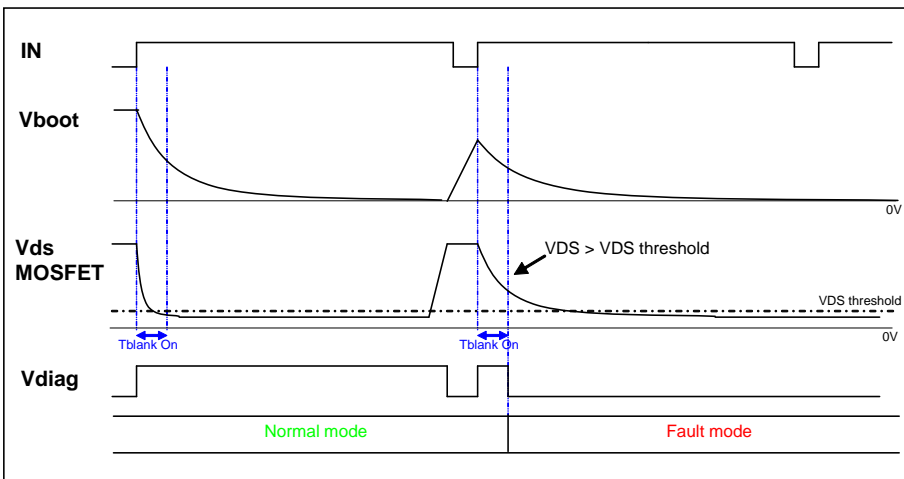

Figure 13

Under voltage protection in short-circuit mode

During short circuit condition, it may happen that the supply voltage drops below the under voltage before the short is detected by the Vds protection due to the blanking time 'Tblank on'.

In under voltage condition the AUIR3200S turns off the MOSFET. The time 'Tblank On' is reset.

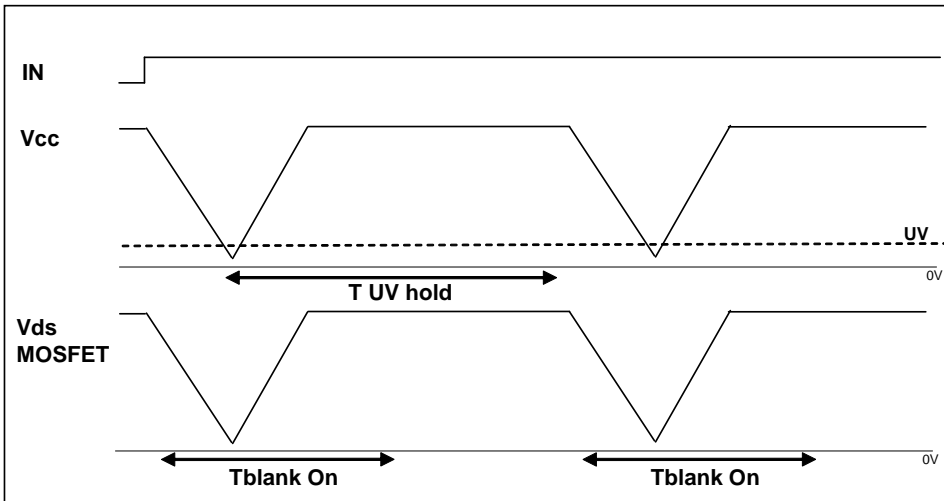

Figure 14

In order to detect the short circuit condition, the AUIR3200S has a counter and after 4 'under voltage' detections, the part is latched and the fault diagnostic is activated. The counter is reset when the part goes to sleep mode.

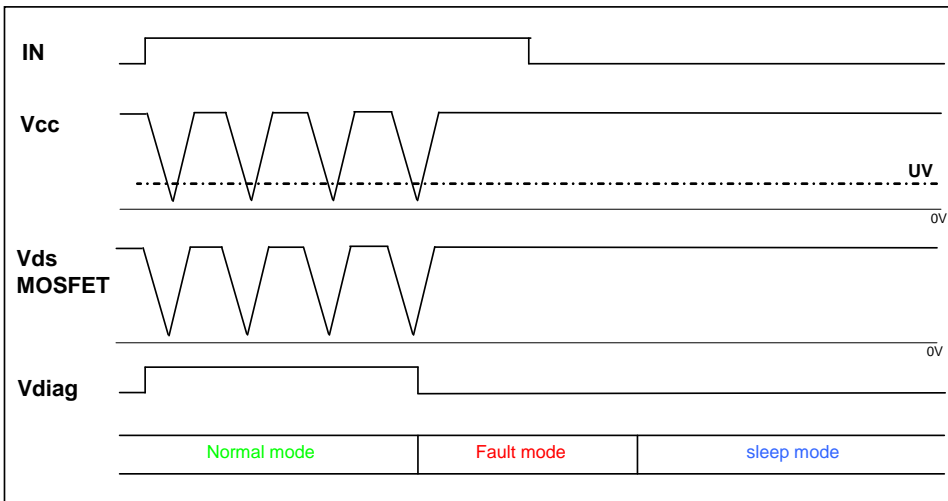

Figure 15

PWM operation ($T_{on} < T_{blank\ on}$)

PWM operation is also possible. The bootstrap feature allows fast switching. When the T_{on} is shorter than the $T_{blank\ on}$, the V_{ds} protection is no longer activated. In order to protect the Power Mosfet, the AUIR3200S integrates a counter which is incremented by the input signal and reset when the V_{ds} voltage is below the V_{ds} threshold. The counter latches off the AUIR3200S after 4 activations. During PWM operation ($T_{on} < T_{blank\ on}$) on a short circuit, the V_{ds} is always above the V_{ds} threshold and 4 activations on the input will latch the AUIR3200S and the fault diagnostic is activated.

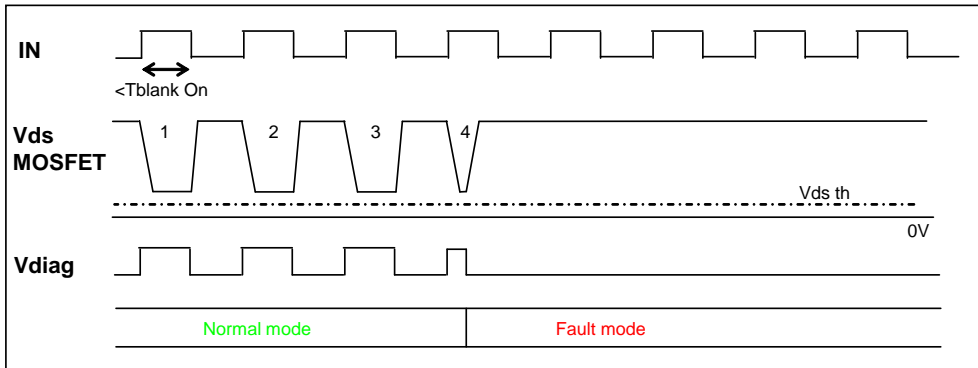

Figure 16

Parameters curves: typical value

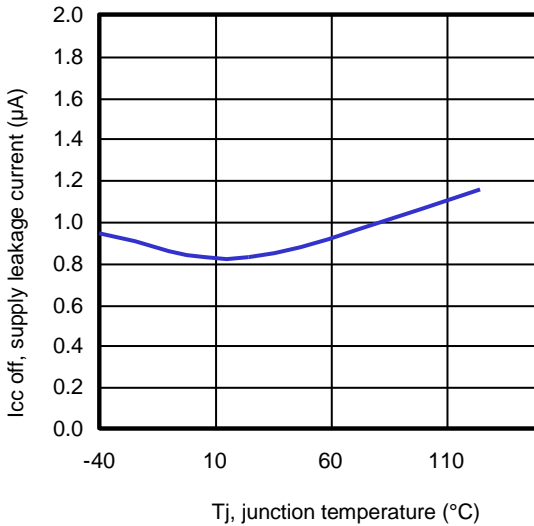

Figure 17: I_{cc off} (µA) Vs T_j (°C) (V_{cc}=14V, V_{in}=0V)

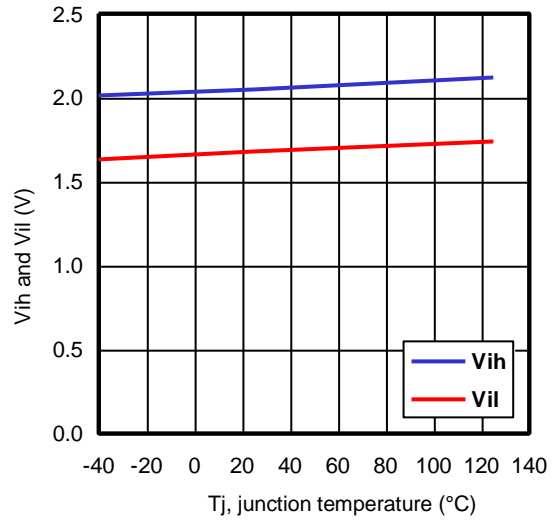

Figure 18: V_{ih} and V_{il} (V) Vs T_j (°C)

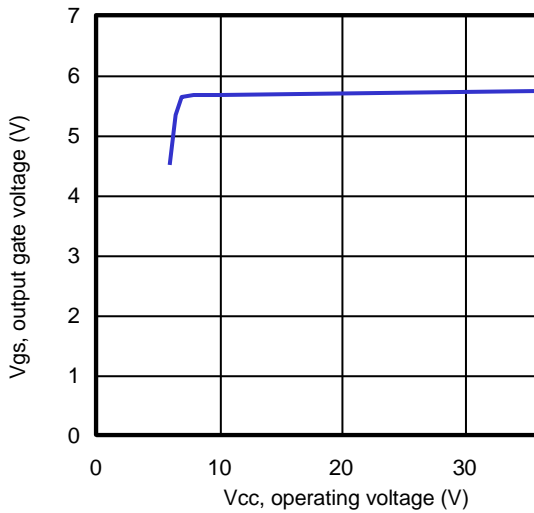
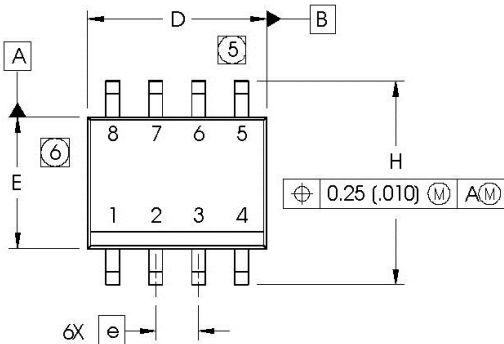

Figure 19: V_{gs} vs V_{cc} with I_{vgS}=50µA

Case Outline – SO8

Dimensions are shown in millimeters (inches)



DIM	INCHES		MILLIMETERS	
	MIN	MAX	MIN	MAX
A	.0532	.0688	1.35	1.75
A1	.0040	.0098	0.10	0.25
b	.013	.020	0.33	0.51
c	.0075	.0098	0.19	0.25
D	.189	.1968	4.80	5.00
E	.1497	.1574	3.80	4.00
e	.050 BASIC		1.27 BASIC	
e1	.025 BASIC		0.635 BASIC	
H	.2284	.2440	5.80	6.20
K	.0099	.0196	0.25	0.50
L	.016	.050	0.40	1.27
y	0°	8°	0°	8°

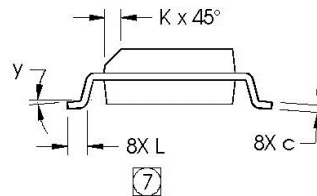
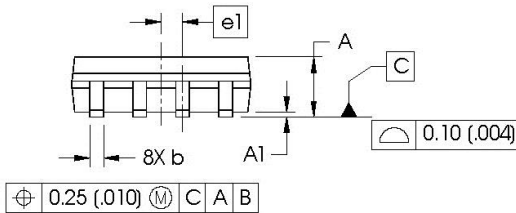

NOTES:

1. DIMENSIONING & TOLERANCING PER ASME Y14.5M-1994.
2. CONTROLLING DIMENSION: MILLIMETER
3. DIMENSIONS ARE SHOWN IN MILLIMETERS (INCHES).
4. OUTLINE CONFORMS TO JEDEC OUTLINE MS-012AA.
- ⑤ DIMENSION DOES NOT INCLUDE MOLD PROTRUSIONS. MOLD PROTRUSIONS NOT TO EXCEED 0.15 (.006).
- ⑥ DIMENSION DOES NOT INCLUDE MOLD PROTRUSIONS. MOLD PROTRUSIONS NOT TO EXCEED 0.25 (.010).
- ⑦ DIMENSION IS THE LENGTH OF LEAD FOR SOLDERING TO A SUBSTRATE.

FOOTPRINT

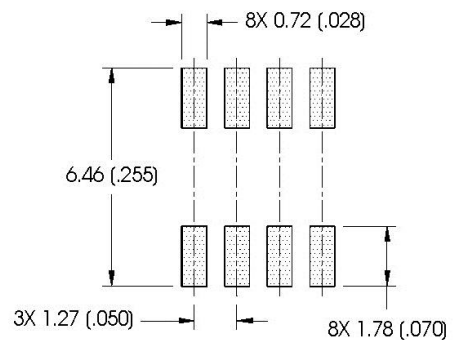

Tape & Reel SO8

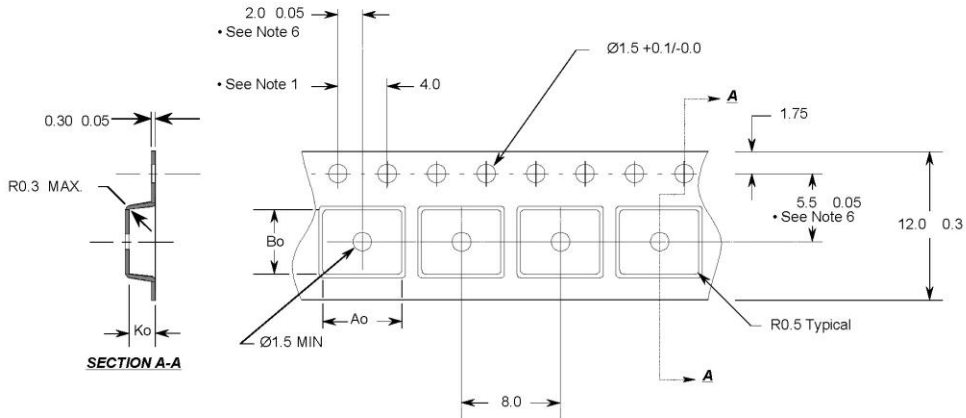

Notes:

1. 10 sprocket hole pitch cumulative tolerance 0.2
2. Camber not to exceed 1mm in 100mm
3. Material: Black Conductive Advantek Polystyrene
4. Ao and Bo measured on a plane 0.3mm above the bottom of the pocket
5. Ko measured from a plane on the inside bottom of the pocket to the top surface of the carrier.
6. Pocket position relative to sprocket hole measured as true position of pocket, not pocket hole.

Ao = 6.4 mm
Bo = 5.2 mm
Ko = 2.1 mm

- All Dimensions in Millimeters -

Part Marking Information

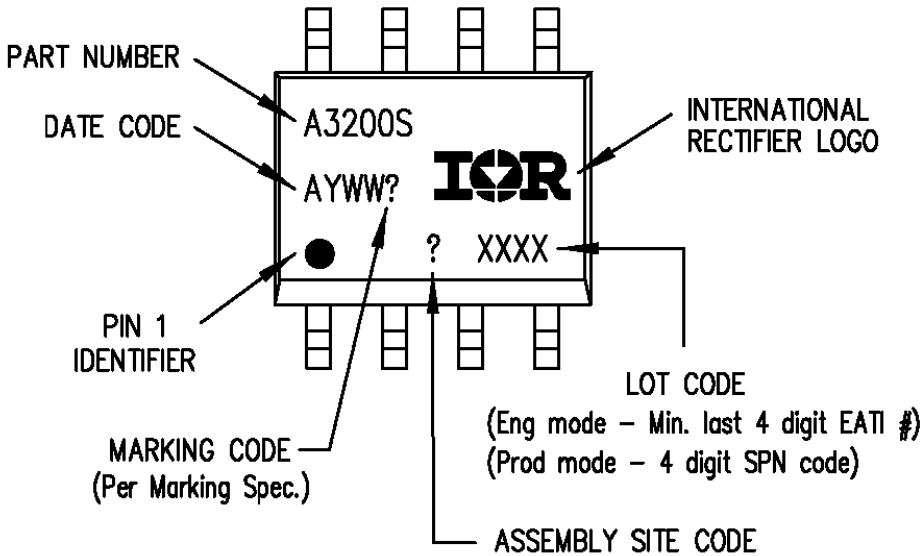

TOP MARKING (LASER)

Qualification Information[†]

Qualification Level		Automotive (per AEC-Q100)	
		Comments: This family of ICs has passed an Automotive qualification. IR's Industrial and Consumer qualification level is granted by extension of the higher Automotive level.	
Moisture Sensitivity Level		SOIC8N	MSL2 260°C (per IPC/JEDEC J-STD-020)
ESD	Machine Model	Class M1B(+/-100V) (per AEC-Q100-003)	
	Human Body Model	Class H1C (+/-1500V) (per AEC-Q100-002)	
	Charged Device Model	Class C4 (+/-1000V) (per AEC-Q100-011)	
IC Latch-Up Test		Class II, Level A (per AEC-Q100-004)	
RoHS Compliant		Yes	

[†] Qualification standards can be found at International Rectifier's web site <http://www.irf.com/>

Published by
Infineon Technologies AG
81726 München, Germany
© Infineon Technologies AG 2015
All Rights Reserved.

IMPORTANT NOTICE

The information given in this document shall in no event be regarded as a guarantee of conditions or characteristics ("Beschaffenhheitsgarantie"). With respect to any examples, hints or any typical values stated herein and/or any information regarding the application of the product, Infineon Technologies hereby disclaims any and all warranties and liabilities of any kind, including without limitation warranties of non-infringement of intellectual property rights of any third party.

In addition, any information given in this document is subject to customer's compliance with its obligations stated in this document and any applicable legal requirements, norms and standards concerning customer's products and any use of the product of Infineon Technologies in customer's applications.

The data contained in this document is exclusively intended for technically trained staff. It is the responsibility of customer's technical departments to evaluate the suitability of the product for the intended application and the completeness of the product information given in this document with respect to such application.

For further information on the product, technology, delivery terms and conditions and prices please contact your nearest Infineon Technologies office (www.infineon.com).

WARNINGS

Due to technical requirements products may contain dangerous substances. For information on the types in question please contact your nearest Infineon Technologies office.

Except as otherwise explicitly approved by Infineon Technologies in a written document signed by authorized representatives of Infineon Technologies, Infineon Technologies' products may not be used in any applications where a failure of the product or any consequences of the use thereof can reasonably be expected to result in personal injury.

Revision History





Revision	Date	Notes/Changes
A	November, 2 nd 2012	Initial release
B	January, 3 rd 2013	Add max Rvds
D	April, 24 th 2015	Add 'Rptc sensor' parameter Add explanation for current protection and temperature protection
E1	June, 3 th 2015	Add Vgs max and Vgs rev max
E3	September, 24 th 2015	IFX template
E4	October, 2 2015	Twkp max added
1.1	May 02, 2016	Ground loss protection Update revision name

Looking for pricing, stock, or lifecycle information?

Click below to explore more details on WIN SOURCE:

-  [View AUIR3200STR on WIN SOURCE](#)
-  [Infineon Technologies](#) Information

Optimize Your Supply Chain with WIN SOURCE Solutions

-  Global Sourcing Solution
-  Obsolete Management
-  Cost Control Management
-  Shortage Management
-  Alternative Solution
-  Excess Inventory Management