



ON Semiconductor®

<http://onsemi.com>

# LV8075LP

Bi-CMOS LSI

## Constant-voltage Control 1-channel Forward/Reverse Motor Driver

### Overview

LV8075LP is a constant voltage control 1-channel forward/reverse motor driver IC.

### Features

- Constant voltage control forward/reverse H-bridge  
Parallel input-Analog value must be entered for constant voltage reference input  
 $V(\text{OUT}) = V(\text{VC}) \times 2.0$
- Built-in thermal protection circuit and under-voltage detection protection circuit

### Specifications

**Absolute Maximum Ratings** at  $T_a = 25^\circ\text{C}$ ,  $\text{SGND} = \text{PGND} = 0\text{V}$

Parameter	Symbol	Conditions	Ratings	Unit
Maximum control power supply voltage	$V_{CC}$ max		6	V
Maximum load power supply voltage	$V_M$ max		6	V
Maximum control pin voltage	$V_C$ max		6	V
Maximum output current	$I_O$ max	OUT1, 2	0.5	A
VREF maximum current	$I_{REF}$ max	VREF	1	mA
Allowable power dissipation	$P_d$ max	Mounted on a circuit board*	700	mW
Operating temperature	$T_{opr}$		-30 to +85	$^\circ\text{C}$
Storage temperature	$T_{stg}$		-40 to +150	$^\circ\text{C}$

\* Specified circuit board : 40.0x50.0x0.8mm<sup>3</sup> : glass epoxy four-layer board

Stresses exceeding Maximum Ratings may damage the device. Maximum Ratings are stress ratings only. Functional operation above the Recommended Operating Conditions is not implied. Extended exposure to stresses above the Recommended Operating Conditions may affect device reliability.

# LV8075LP

**Allowable Operating Range** at  $T_a = 25^\circ\text{C}$ ,  $\text{SGND} = \text{PGND} = 0\text{V}$

Parameter	Symbol	Conditions	Ratings	Unit
Control power-supply voltage	$V_{\text{CC}}$		2.5 to 5.5	V
Load power-supply voltage	$V_{\text{M}}$		2.5 to 5.5	V
Output control input voltage	$V_{\text{cont}}$	VC pin	0 to $V_{\text{CC}}-1$	V
Input pin "H" voltage	$V_{\text{INH}}$	IN1, 2, EN pin	$V_{\text{CC}} \times 0.6$ to $V_{\text{CC}}+0.3$	V
Input pin "L" voltage	$V_{\text{INL}}$	IN1, 2, EN pin	$-0.1$ to $V_{\text{CC}} \times 0.2$	V

**Electrical Characteristics** at  $T_a = 25^\circ\text{C}$ ,  $V_{\text{CC}} = V_{\text{M}} = 3.0\text{V}$ ,  $\text{PGND} = \text{SGND} = 0\text{V}$ , unless otherwise specified.

Parameter	Symbol	Conditions	Ratings			Unit
			min	typ	max	
Standby current consumption 1	$I_{\text{CCO}}$	EN, IN1, 2 = H/L/L or EN = L			1	$\mu\text{A}$
Standby current consumption 1	$I_{\text{MO}}$	EN, IN1, 2 = H/L/L or EN = L			1	$\mu\text{A}$
Operating current consumption	$V_{\text{CC1}}$	EN = H, IN1 or IN2 = H		0.5	1.0	mA
H-level input current	$I_{\text{INH}}$	200k $\Omega$ pull-down, $V_{\text{IN}} = 3\text{V}$	10	15	20	$\mu\text{A}$
L-level input current	$I_{\text{INL}}$	$V_{\text{IN}} = 0\text{V}$		0	1	$\mu\text{A}$
Reference voltage output	$V_{\text{REF}}$	$I_{\text{REF}} = 500\mu\text{F}$	1.4	1.5	1.6	V
Output on-resistance	$R_{\text{on1}}$	Total of top and bottom		1.75	2.5	$\Omega$
Constant-voltage control output voltage	$V_{\text{OUT}}$	VC = 1.0V	1.94	2.0	2.06	V
Under-voltage detection operating voltage	$V_{\text{CS}}$	$V_{\text{CC}}$ Voltage	2.1	2.2	2.35	V
Thermal protection temperature	TSD	Design guarantee value*	150	180	210	$^\circ\text{C}$
Output rise time	$T_{\text{r}}$	(Note)		1.6	3.0	$\mu\text{s}$
Output fall time	$T_{\text{f}}$	(Note)		0.2	1.0	$\mu\text{s}$

\* Design guarantee value and no measurement is made.

Note : Specify rising control start time  $\rightarrow$  90% of OUT output voltage, and falling control start time  $\rightarrow$  10% of OUT output voltage.

## Package Dimensions

unit : mm (typ)

3318

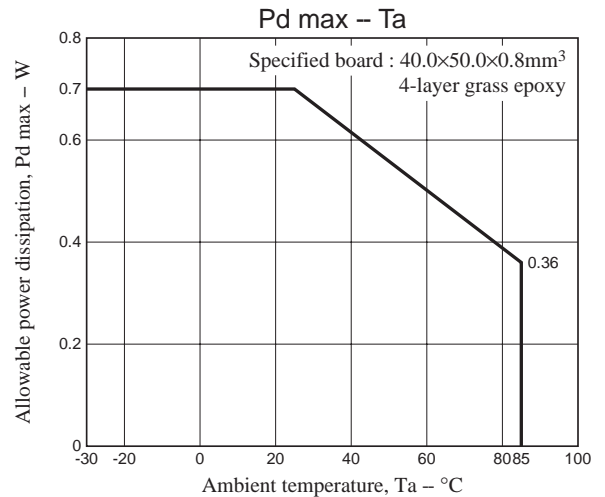
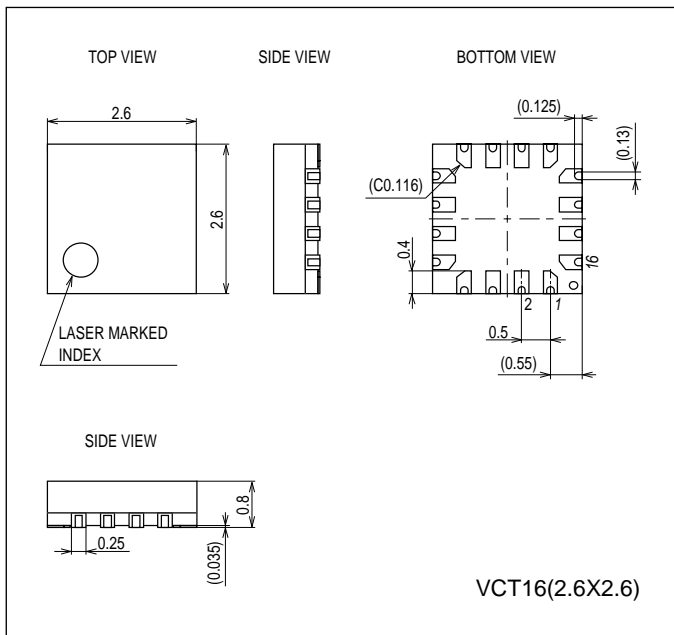

# LV8075LP

## Pin Assignment

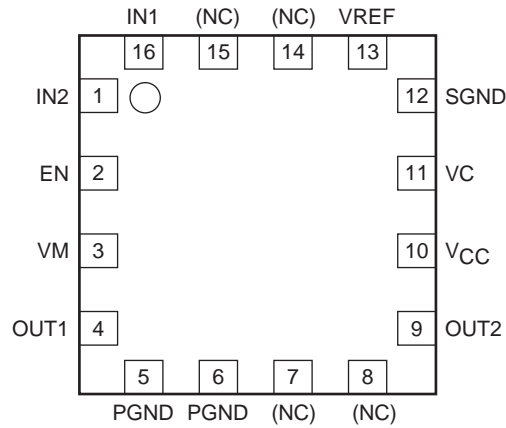

Top view

## Block Diagram

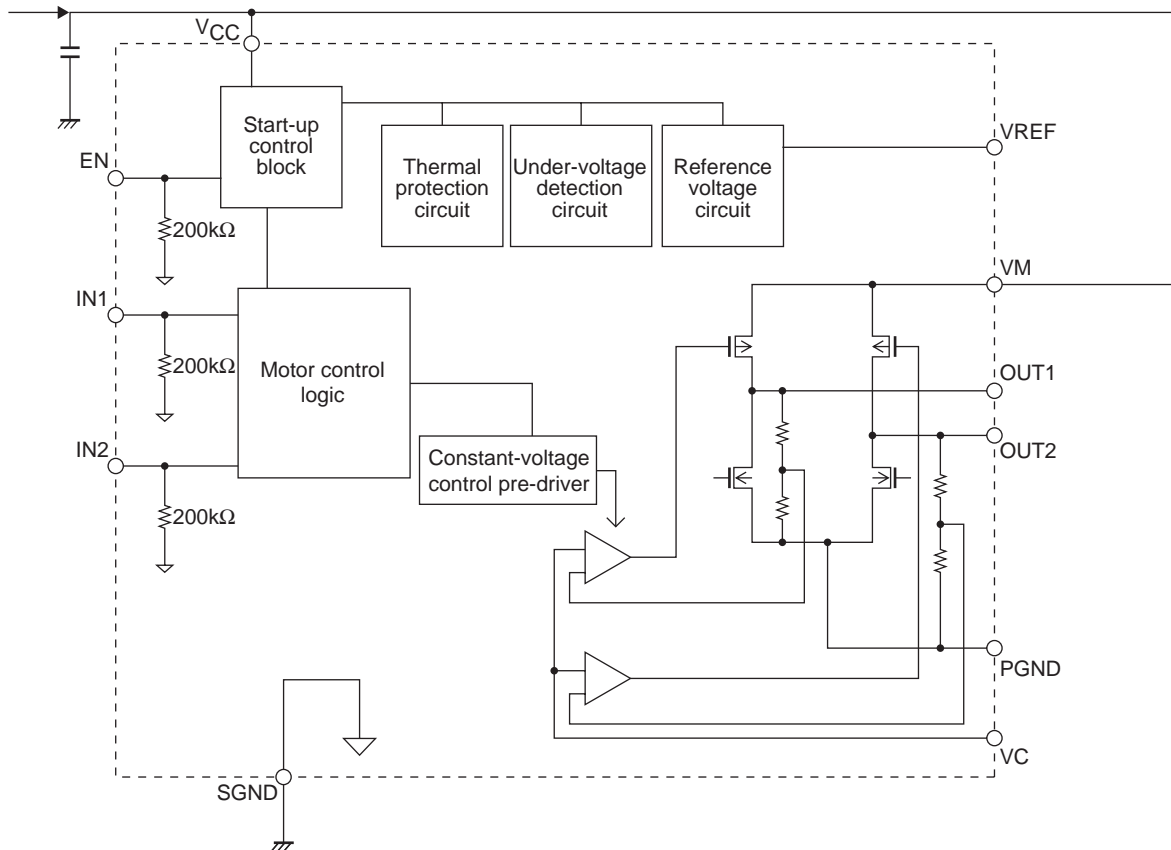

## Truth Table

Constant voltage output H-bridge

EN	IN1	IN2	OUT1	OUT2	Mode
H	H	H	L	L	Brake
	H	L	H	L	Forward evolution
	L	H	L	H	Reverse rotation
	L	L	off	off	Stand by
L	-	-	off	off	Stand by

"-" entries indicate don't care state, "off" indicates output off state, insert 20kΩ impedance across PGND.

Constant voltage output value :  $V(OUT) = V(VC) \times 2.0$

# LV8075LP



## Pin Functions

Pin No.	Pin name	Description
10	V <sub>CC</sub>	Power supply pin for control
5, 6	PGND	Power ground pins for IC
12	SGND	IC system ground
3	VM	Power supply pin for constant voltage output H-bridge
2	EN	IC enable pin. Power-saving mode is established when L-level is applied. Pulled-down with 200k $\Omega$
16, 1	IN1, 2	Input pins for manipulating constant-current output H-bridge (OUT1, 2). Pulled-down with 200k $\Omega$
4, 9	OUT1, 2	Constant voltage H-bridge output pins
13	VREF	Reference voltage output, outputs 1.5V
11	VC	Analog voltage input pin for constant voltage setting. Must be short-circuited to V <sub>CC</sub> pin when using saturation control.

ON Semiconductor and the ON logo are registered trademarks of Semiconductor Components Industries, LLC (SCILLC). SCILLC owns the rights to a number of patents, trademarks, copyrights, trade secrets, and other intellectual property. A listing of SCILLC's product/patent coverage may be accessed at [www.onsemi.com/site/pdf/Patent-Marking.pdf](http://www.onsemi.com/site/pdf/Patent-Marking.pdf). SCILLC reserves the right to make changes without further notice to any products herein. SCILLC makes no warranty, representation or guarantee regarding the suitability of its products for any particular purpose, nor does SCILLC assume any liability arising out of the application or use of any product or circuit, and specifically disclaims any and all liability, including without limitation special, consequential or incidental damages. "Typical" parameters which may be provided in SCILLC data sheets and/or specifications can and do vary in different applications and actual performance may vary over time. All operating parameters, including "Typicals" must be validated for each customer application by customer's technical experts. SCILLC does not convey any license under its patent rights nor the rights of others. SCILLC products are not designed, intended, or authorized for use as components in systems intended for surgical implant into the body, or other applications intended to support or sustain life, or for any other application in which the failure of the SCILLC product could create a situation where personal injury or death may occur. Should Buyer purchase or use SCILLC products for any such unintended or unauthorized application, Buyer shall indemnify and hold SCILLC and its officers, employees, subsidiaries, affiliates, and distributors harmless against all claims, costs, damages, and expenses, and reasonable attorney fees arising out of, directly or indirectly, any claim of personal injury or death associated with such unintended or unauthorized use, even if such claim alleges that SCILLC was negligent regarding the design or manufacture of the part. SCILLC is an Equal Opportunity/Affirmative Action Employer. This literature is subject to all applicable copyright laws and is not for resale in any manner.

## Looking for pricing, stock, or lifecycle information?

Click below to explore more details on WIN SOURCE:

-  [View LV8075LPGEVB on WIN SOURCE](#)
-  [ON Semiconductor](#) Information

## Optimize Your Supply Chain with WIN SOURCE Solutions

-  Global Sourcing Solution
-  Obsolete Management
-  Cost Control Management
-  Shortage Management
-  Alternative Solution
-  Excess Inventory Management