

# LV25500PQA



ON Semiconductor®

<http://onsemi.com>

Bi-CMOS LSI

## FM Multiplex Broadcasting Receive Tuner

### Overview

LV25500PQA is in-vehicle FM multiplex broadcasting receive only tuner IC that makes FM tuner, PLL, and the RDS demodulator single-chip.

ON Semiconductor's unique technology enables to reduce a large number of external components for high frequency like coils, ceramic filters and varicaps which were required for conventional tuner IC.

Small FM multiple tuner that can be installed also in PND etc. including AVN can be composed.

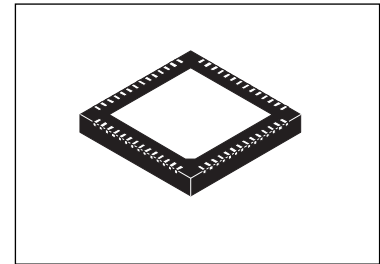

WQFN56 7x7, 0.4P

### Features

- No need for adjustment work.
- The AF search processing on the main tuner side is unnecessary according to using with the main tuner together.
- The high sensitivity reception and the high strong input tolerance are united by LNA built into equipped with the WIDE-AGC function.
- The third and fifth high harmonic rejection type mixers of a local oscillation are adopted.
- The switch of UPPER/LOWER of a local oscillation and IF-BPF of injection is possible when the image signal is detected.
- The complex BPF of the image attenuation type is built into.
- IF-BPF is made built-in by LOW-IF frequency (IF = 575 kHz) adoption.
- Dynamic range of S meter is wide.
- S meter tuning-system is adopted.
- The DLL demodulation method is adopted for FM demodulation circuit.
- LPF for the carrier removal is built into.
- S meter level, the adjacent obstruction level, and the multipath can be detected and read by way of I<sup>2</sup>C BUS.
- BPF (57 kHz) for the BPSK detection is built into.
- It becomes easy to miniaturize the tuner set with built-in the RDS demodulator.
- 36.8MHz is adopted for the crystal oscillation frequency.
- The number of external parts is little.

### Functions

- FM tuner function
- Antenna dumping control function
- Local oscillation of PLL control type
- WIDE/NARROW/IF-AGC function
- DLL demodulator
- 57kHz carrier recovery and re-clock regeneration
- BPSK decode / differential decode
- ID reset function
- I<sup>2</sup>C BUS control
- I<sup>2</sup>C reset function
- Standby function

\* I<sup>2</sup>C Bus is a trademark of Philips Corporation.

### ORDERING INFORMATION

See detailed ordering and shipping information on page 13 of this data sheet.

# LV25500PQA

## Specification

### Absolute Maximum Ratings at Ta = 25°C

| Parameter                   | Symbol              | Conditions                  | Ratings      | unit |
|-----------------------------|---------------------|-----------------------------|--------------|------|
| Maximum supply voltage      | V <sub>CC</sub> max | Ta = 25°C                   | 6.0          | V    |
| Maximum input voltage       | VIN1max             | LNA_P, LNA_N                | -0.3 to 6.0  | V    |
|                             | VIN2max             | TEST, RST, XSTBY, XRST      | -0.3 to 3.45 | V    |
|                             | VIN3max             | SDA, SCL                    | -0.3 to 3.45 | V    |
| Maximum output voltage      | VO1max              | LPFO, BPSK, SMETER          | -0.3 to 6.0  | V    |
|                             | VO2max              | RDS-ID, RDDA, RDCL, INT, SD | -0.3 to 3.45 | V    |
|                             | VO3max              | SDA                         | -0.3 to 3.45 | V    |
| Allowable power dissipation | Pd max              | Ta≤85°C (*)Specified board  | 1.38         | W    |
| Operating temperature       | Topr                |                             | -40 to +85   | °C   |
| Storage temperature         | Tstg                |                             | -50 to +150  | °C   |

(\*) Specified board is attached : 80.0mm×80.0mm×1.0mm, glass epoxy board

Stresses exceeding those listed in the Maximum Ratings table may damage the device. If any of these limits are exceeded, device functionality should not be assumed, damage may occur and reliability may be affected.

Note : Machine model ESD voltage level of the pin 18 is less than 200V, because their high frequency characteristics are extremely important. Handle pins 18 with care to prevent electrostatic breakdown.

### Operating Conditions at Ta = 25°C

| Parameter                      | Symbol             | Conditions             | Ratings        |
|--------------------------------|--------------------|------------------------|----------------|
| Recommended supply voltage     | V <sub>CC</sub>    |                        | 5.0V           |
| Operating supply voltage range | V <sub>CC</sub> op |                        | 4.5 to 5.5V    |
| Input High level voltage       | VINH1              | TEST, RST, XSTBY, XRST | 3 to 3.45V     |
|                                | VINH2              | SDA, SCL               | 2.3 to 3.45V   |
| Input Low level voltage        | VINL1              | TEST, RST, XSTBY, XRST | 0.5V or less   |
|                                | VINL2              | SDA, SCL               | 0.9V or less   |
| SCL clock frequency            | fSCL               | SCL                    | 400kHz or less |

Functional operation above the stresses listed in the Recommended Operating Ranges is not implied. Extended exposure to stresses beyond the Recommended Operating Ranges limits may affect device reliability.

### Range of Reception Frequency

| Parameter           | Symbol | Conditions | Ratings       | unit |
|---------------------|--------|------------|---------------|------|
| FM input frequency1 | FM_EU  | FM EU      | 87.5 to 108.0 | MHz  |
| FM input frequency2 | FM_US  | FM US      | 87.9 to 108.1 | MHz  |
| FM input frequency3 | FM_JP  | FM JP      | 76 to 90      | MHz  |

The constant in application circuit is different in FM\_EU, FM\_US and FM\_JP.

## LV25500PQA

**Electric Characteristics** at Ta = 25°C, VCC = 5.0V

fc = 98.1MHz, Vin = 60dBuVEMF, fm = 1kHz, Audio filter: HPF = 100Hz, LPF = 15kHz

| Parameter                      | Symbol | Conditions   | min         | typ | max | unit    |
|--------------------------------|--------|--|-------------|-----|-----|---------|
| Usable sensitivity 1 (S/N30dB) | SN30   | 22.5kHz dev, fm = 1kHz, S/N = 30dB input level     | -           | 12  | 20  | dBuVEMF |
| Usable sensitivity 2 (S/N10dB) | SN10   | 7.5kHz dev, fm = 76kHz, S/N = 10dB input level [1] | -           | 27  | -   | dBuVEMF |
| SN ratio 1                     | SN1    | 22.5kHz dev, fm = 1kHz                             | 34          | 46  | -   | dB      |
| SN ratio 2                     | SN2    | 7.5kHz dev, fm = 76kHz [1]                         | -           | 23  | -   | dB      |
| AM suppression ratio           | AMR    | AM 30% mod   | 34          | 45  | -   | dB      |
| Image removal ratio            | IMR    | 22.5kHz dev, fm = 1kHz                             | -           | 46  | -   | dB      |
| Audio output level 1           | ADO1   | 7.5kHz dev, fm = 1kHz [1]                          | 12          | 30  | 45  | mVrms   |
| Audio output level 2           | ADO2   | 7.5kHz dev, fm = 76kHz [1]                         | 12          | 23  | 45  | mVrms   |
| SD sensitivity                 | SDS    | LNA input level when SD terminal is on.            | 13          | 20  | 27  | dBuVEMF |
| Center frequency               | f0     | 57kHz BPF peak frequency                           |             | 57  |     | kHz     |
| Output (L) level voltage       | VOL1   | RDDA, RDCL, INT, SD IOL=0.5mA                      | -           | -   | 0.5 | V       |
|                                | VOL2   | RDS-ID, IOL=0.5mA                                  | -           | -   | 0.5 | V       |
|                                | VOL3   | SDA (when VDD pull up)                             | -           | -   | 0.5 | V       |
| Output (H) level voltage       | VOH1   | RDDA, RDCL, INT, SD IOH=0.5mA                      | 2.3         | -   | -   | V       |
|                                | VOH2   | SDA (when VDD pull up)                             | 0.7*VDD [2] |     | -   | V       |
| Current consumption 1          | ICC1   | When no signal input RDS mode                      | 125         | 165 | 205 | mA      |
| Current consumption 2          | ICC2   | When no signal input VICS mode                     | 120         | 155 | 190 | mA      |

[1] Audio filter : HPF = 100Hz, LPF = OFF

[2] VDD :  $\mu$ -COM Supply Voltage

Product parametric performance is indicated in the Electrical Characteristics for the listed test conditions, unless otherwise noted. Product performance may not be indicated by the Electrical Characteristics if operated under different conditions.

**RDS input/output Format**

|        |   |
|--------|---|
|        | RST Pin                                 |
| RST= 0 | Normal operation                        |
| RST= 1 | Reset of RDS-ID and demodulator circuit |

  

|              |            |
|--------------|------------|
|              | RDS-ID     |
| RDS-IDoutput | Active-Low |

**RDCL/RDDA Output timing**

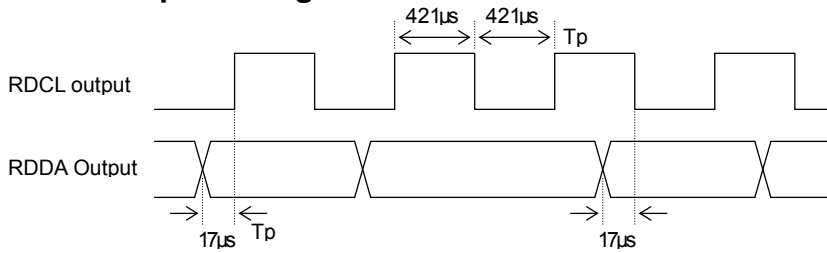

**RDS-ID Output timing**

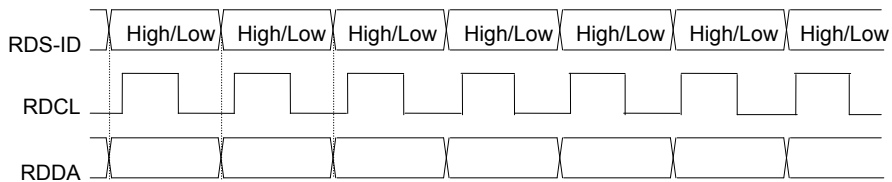

Note : RDS-ID is High : data with Low RDS reliability, Low: data with High RDS reliability

**RST operation**

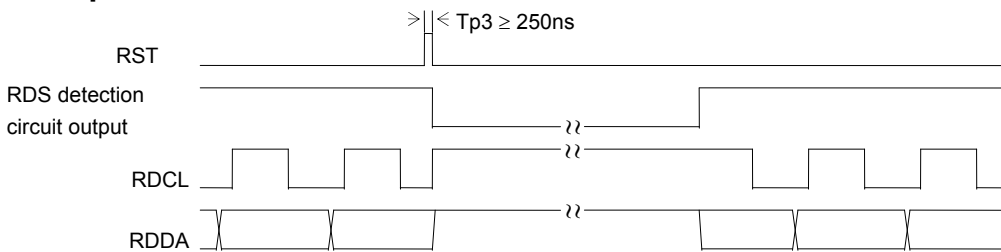

Note : RDCL and RDDA outputs keep high level after input of RST until RDS detection circuit output is detected.

Note : When the reception channel is changed, a memory reset must be applied using RST input.

**Package Dimensions**

WQFN56 (7.0mm x 7.0mm)

unit : mm

**WQFN56 7x7, 0.4P**

CASE 510BD

ISSUE O

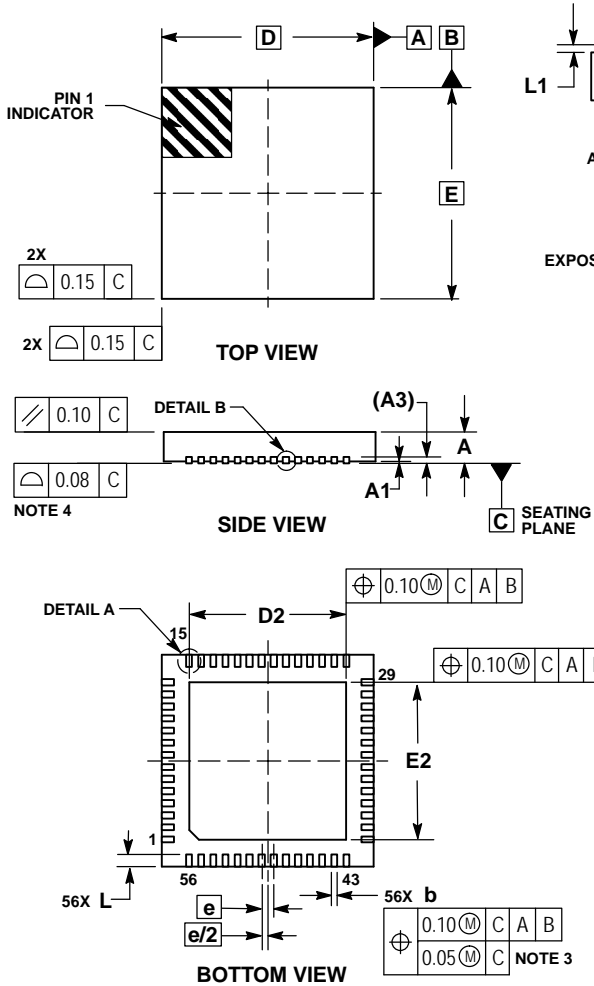

- NOTES:
1. DIMENSIONS AND TOLERANCING PER ASME Y14.5M, 1994.
  2. CONTROLLING DIMENSION: MILLIMETERS.
  3. DIMENSION b APPLIES TO THE PLATED TERMINAL AND IS MEASURED BETWEEN 0.15 AND 0.25MM FROM THE TERMINAL TIP.
  4. COPLANARITY APPLIES TO THE EXPOSED PAD AS WELL AS THE TERMINALS.

| MILLIMETERS |      |      |
|-------------|------|------|
| DIM         | MIN  | MAX  |
| A           | ---  | 0.80 |
| A1          | 0.00 | 0.05 |
| A3          | 0.20 | REF  |
| b           | 0.15 | 0.25 |
| D           | 7.00 | BSC  |
| D2          | 5.10 | 5.30 |
| E           | 7.00 | BSC  |
| E2          | 5.10 | 5.30 |
| e           | 0.40 | BSC  |
| L           | 0.30 | 0.50 |
| L1          | 0.00 | 0.15 |

**GENERIC MARKING DIAGRAM\***

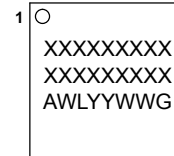

- A = Assembly Location
- WL = Wafer Lot
- YY = Year
- WW = Work Week
- G = Pb-Free Package

\*This information is generic. Please refer to device data sheet for actual part marking. Pb-Free indicator, "G" or microdot "▪", may or may not be present.

**RECOMMENDED SOLDERING FOOTPRINT\***

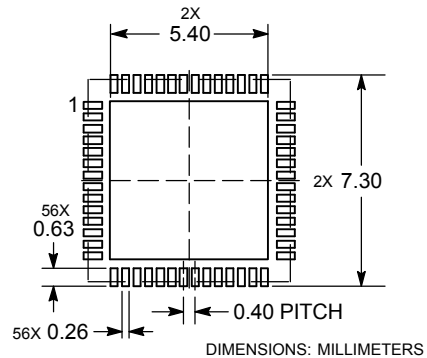

\*For additional information on our Pb-Free strategy and soldering details, please download the ON Semiconductor Soldering and Mounting Techniques Reference Manual, SOLDERRM/D.

Block Diagram

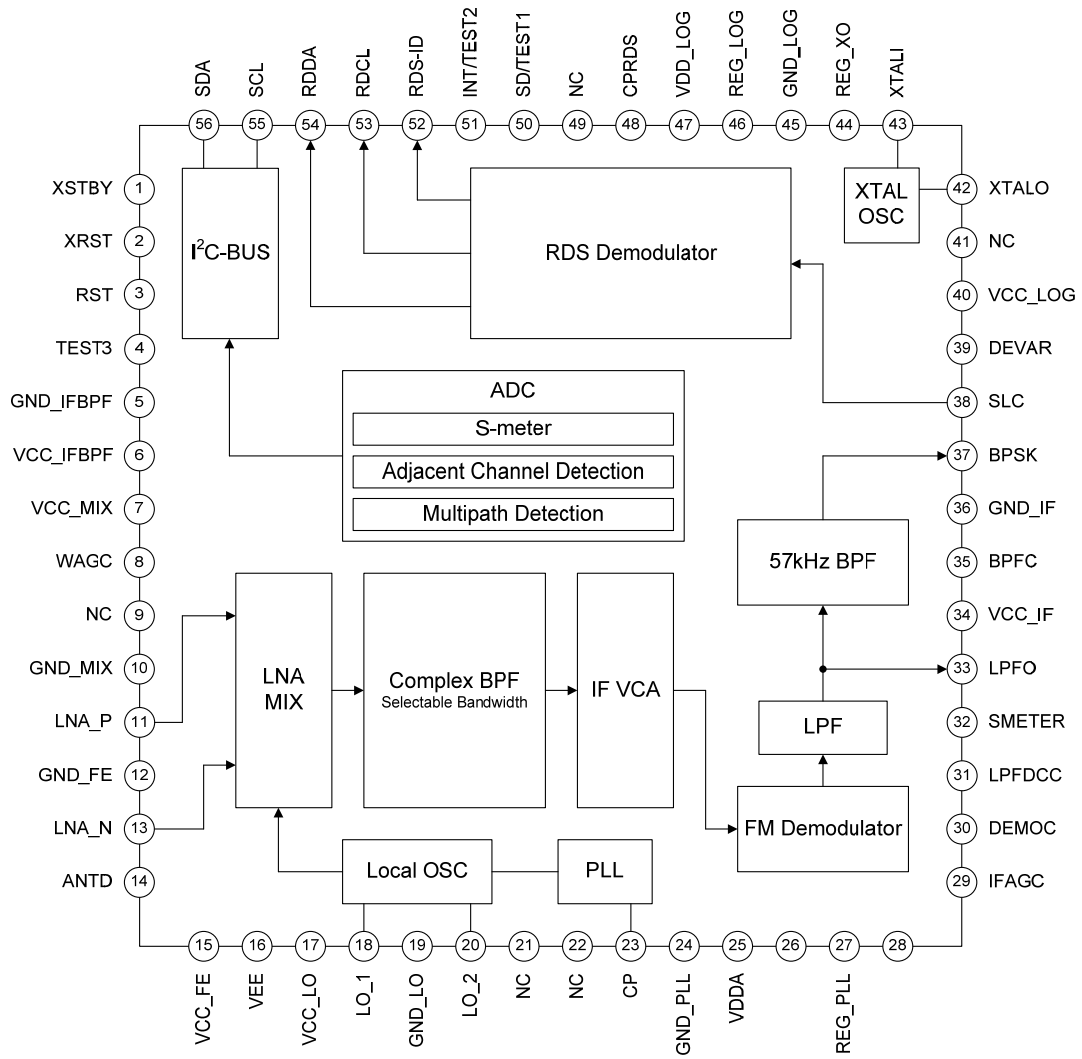

# LV2550PQA

## Example of application circuit (FM\_US) [1] [2] [3] [4] [5]

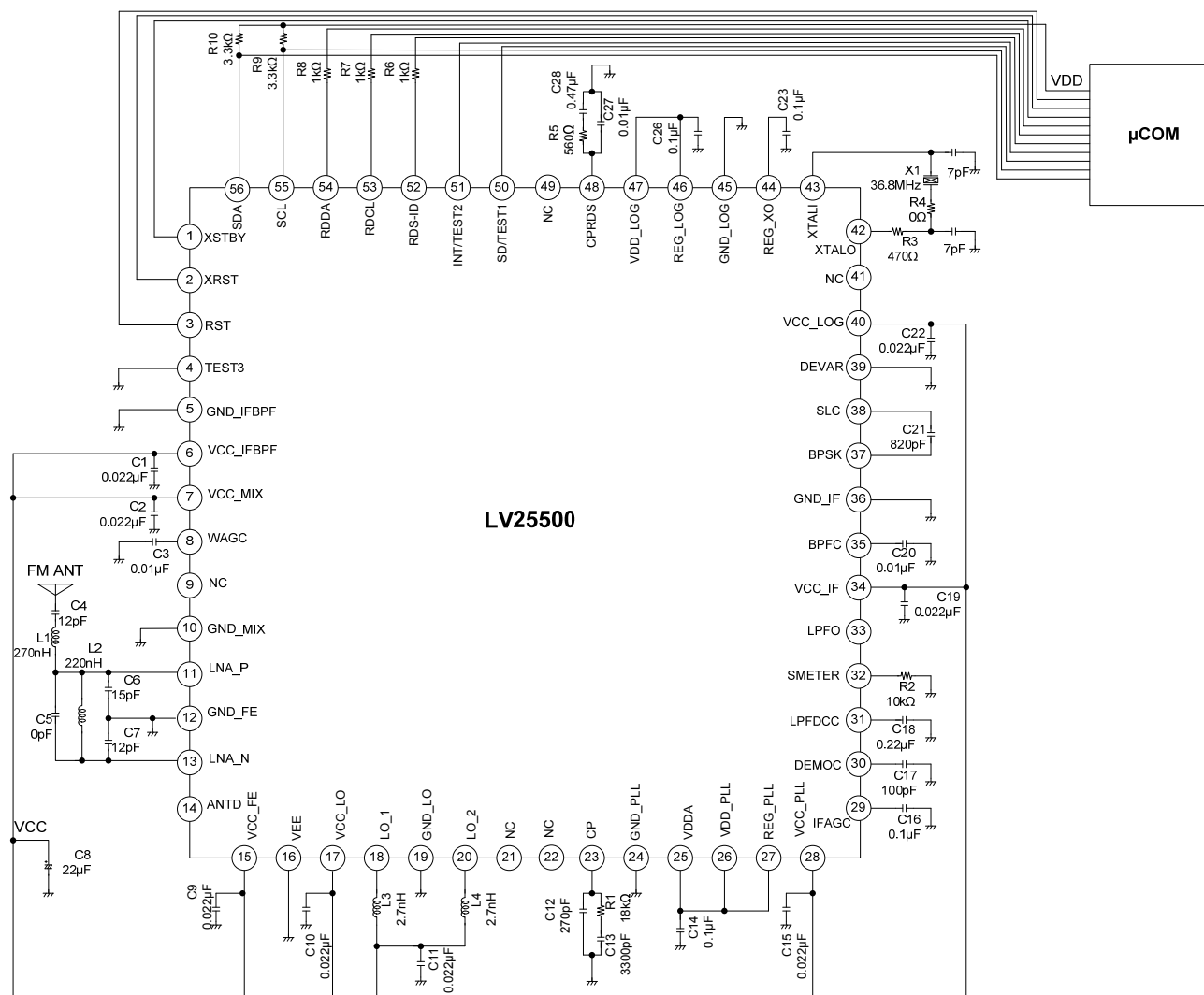

### Used Components(FM\_US)

| Component | Parameter      | Value   | Supplier | Type           |
|-----------|----------------|---------|----------|----------------|
| L1        | RF BPF coil    | 270nH   | SAGAMI   | C2012C-R27G-RC |
| L2        | RF BPF coil    | 220nH   | SAGAMI   | C2012C-R22G-RC |
| L3/L4     | Local OSC coil | 2.7nH   | SAGAMI   | C2012H-2N7D-RD |
| X1        | Crystal        | 36.8MHz | KDS      | DSX321G        |

- [1] The external parts for crystal oscillation circuit terminal (pin42 and pin43) need to match the quartz vibrator. R3, R4, C24, C25 are the tentative arrangement parts.
- [2] Caution is required for layout of the board because the parasitic capacitance between pin42, pin43 and Power, GND, etc causes the decrease of the margin of the crystal oscillation and the deviation of the crystal frequency, etc.
- [3] This IC uses the signal of FM band frequency (VCO divided into 1/4) which leaks into ANT pin. If the VCO leakage affects the performance of the system, make sure to connect an isolator on ANT pin path.
- [4] REG (pin27, pin44, pin46) is only used for LV25500.
- [5] This example of application circuit, the power-supply voltage becomes the circuit using 3.3V  $\mu$ -COM.  
The bi-directional level shifter circuit is connecting two different voltage sections in I2C-Bus system.

Example of level shift circuit

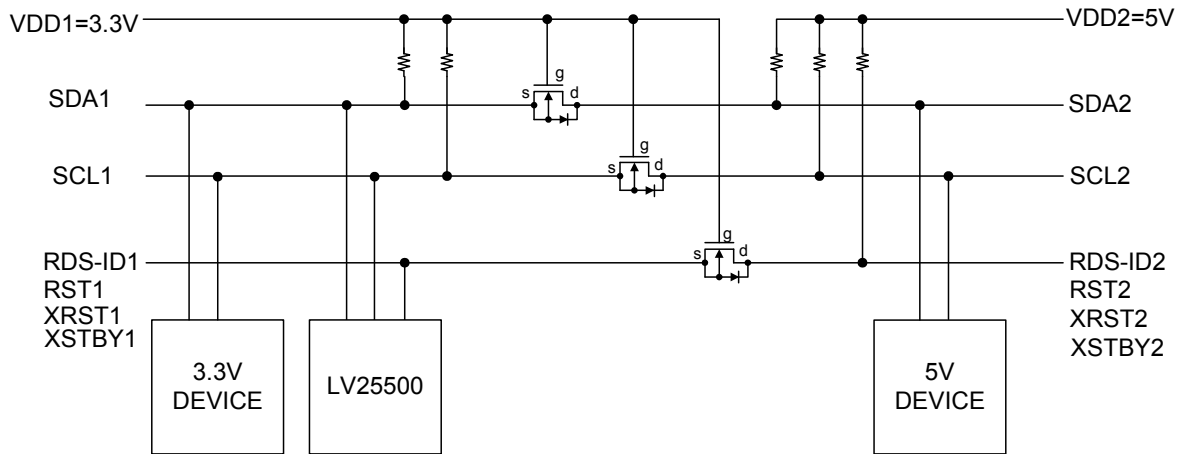

**Pin description**

| Pin | Name      | I/O | Explanation  |
|-----|-----------|-----|--|
| 1   | XSTBY     | I   | Standby pin(0:stanby, 1:standby release)                                   |
| 2   | XRST      | I   | Tuner reset pin (0:reset, 1:reset release)                                 |
| 3   | RST       | I   | RDS-ID reset pin(Positive polarity)  |
| 4   | TEST3     | -   | Test pin   |
| 5   | GND_IFBPF | P   | GND pin for IF BPF   |
| 6   | VCC_IFBPF | P   | VCC pin for IF BPF   |
| 7   | VCC_MIX   | P   | VCC pin for MIXER  |
| 8   | WAGC      | O   | Capacity pin for WAGC  |
| 9   | NC        | NC  | No connection  |
| 10  | GND_MIX   | P   | GND pin for MIXER  |
| 11  | LNA_P     | I   | Input pin for LNA+   |
| 12  | GND_FE    | P   | GND pin for LNA  |
| 13  | LNA_N     | I   | Input pin for LNA-   |
| 14  | ANTD      | O   | ANT dumping control pin  |
| 15  | VCC_FE    | P   | Power-supply pin for LNA   |
| 16  | VEE       | P   | GND pin for ESD  |
| 17  | VCC_LO    | P   | VCC pin for local oscillation  |
| 18  | LO_1      | O   | Inductor connection pin for local oscillation                              |
| 19  | GND_LO    | P   | GND pin for local oscillation  |
| 20  | LO_2      | O   | Inductor connection pin for local oscillation                              |
| 21  | NC        | NC  | No connection  |
| 22  | NC        | NC  | No connection  |
| 23  | CP        | O   | Capacity pin for PLL charge pump   |
| 24  | GND_PLL   | P   | GND pin for PLL logic  |
| 25  | VDDA      | P   | Power-supply pin for logic   |
| 26  | VDD_PLL   | P   | Power-supply pin for PLL logic   |
| 27  | REG_PLL   | O   | Regulator capacity pin for PLL logic                                       |
| 28  | VCC_PLL   | P   | Power-supply pin for Regulator   |
| 29  | IFAGC     | O   | Capacity pin for IFAGC   |
| 30  | DEMOC     | O   | Capacity pin for demodulation/detection                                    |
| 31  | LPFDCC    | O   | Capacity pin for LPF DC cancel   |
| 32  | SMETER    | O   | S-meter output pin   |
| 33  | LPFO      | O   | FM demodulation output pin (After band limitation)                         |
| 34  | VCC_IF    | P   | VCC pin IF   |
| 35  | BPFC      | O   | Capacity pin for BPF   |
| 36  | GND_IF    | P   | GND pin for IF   |
| 37  | BPSK      | O   | Bi-phase data career output pin  |
| 38  | SLC       | I   | Data slicer input pin  |
| 39  | DEVAR     | I   | Device address setting pin   |
| 40  | VCC_LOG   | P   | VCC pin for Regulator  |
| 41  | NC        | NC  | No connection  |
| 42  | XTALO     | O   | Crystal resonance element connection pin                                   |
| 43  | XTALI     | I   | Crystal resonance element connection pin                                   |
| 44  | REG_XO    | O   | Regulator pin for crystal  |
| 45  | GND_LOG   | P   | GND pin for control logic  |
| 46  | REG_LOG   | O   | Regulator pin for control logic  |
| 47  | VDD_LOG   | P   | Power-supply pin for control logic   |
| 48  | CPRDS     | O   | PLL charge pump pin for RDS clock generation                               |
| 49  | NC        | NC  | No connection  |
| 50  | SD/TEST1  | O   | Station detector pin/Test pin  |
| 51  | INT/TEST2 | O   | Interrupt flag pin/Test pin  |
| 52  | RDS-ID    | O   | RDS reliability data output pin<br>(0:high reliability, 1:low reliability) |
| 53  | RDCL      | O   | RDS clock output pin   |
| 54  | RDDA      | O   | RDS data output pin  |
| 55  | SCL       | I   | Serial data clock input pin  |
| 56  | SDA       | I/O | Serial data input/output pin   |

**I<sup>2</sup>C Bus Communication Format**

Device address (in case of 39pin, DEVAR, pull down) Normal

| MSB |    |    |    |    |    |    | LSB | Function         |
|-----|----|----|----|----|----|----|-----|------------------|
| A7  | A6 | A5 | A4 | A3 | A2 | A1 | A0  |                  |
| 1   | 1  | 0  | 0  | 0  | 0  | 0  | 0   | WRITE mode (C0h) |
| 1   | 1  | 0  | 0  | 0  | 0  | 0  | 1   | READ mode (C1h)  |

Device address (in case of 39pin, DEVAR, pull up)

| MSB |    |    |    |    |    |    | LSB | Function         |
|-----|----|----|----|----|----|----|-----|------------------|
| A7  | A6 | A5 | A4 | A3 | A2 | A1 | A0  |                  |
| 1   | 1  | 0  | 0  | 0  | 0  | 1  | 0   | WRITE mode (C2h) |
| 1   | 1  | 0  | 0  | 0  | 0  | 1  | 1   | READ mode (C3h)  |

Register Address: Reg 0 ~ Reg 2Fh

| MSB |    |    |    |    |    |    | LSB | Function    |
|-----|----|----|----|----|----|----|-----|-------------|
| A7  | A6 | A5 | A4 | A3 | A2 | A1 | A0  |             |
| 0   | 0  | 0  | 0  | 0  | 0  | 0  | 0   | Reg0 : 00h  |
| 0   | 0  | 0  | 0  | 0  | 0  | 0  | 1   | Reg1 : 01h  |
| 0   | 0  | 0  | 0  | 0  | 0  | 1  | 0   | Reg2 : 02h  |
| :   | :  | :  | :  | :  | :  | :  | :   | :           |
| 0   | 0  | 1  | 0  | 1  | 1  | 0  | 1   | Reg29 : 2Dh |
| 0   | 0  | 1  | 0  | 1  | 1  | 1  | 0   | Reg30 : 2Eh |
| 0   | 0  | 1  | 0  | 1  | 1  | 1  | 1   | Reg31 : 2Fh |

- Bus transmission format description

Format conforms to the I<sup>2</sup>C standard (see below).

- Start condition
- Repeated start condition
- Stop condition
- Write byte
- Read byte

Start, Repeated start, and stop conditions are defined under the conditions shown below.

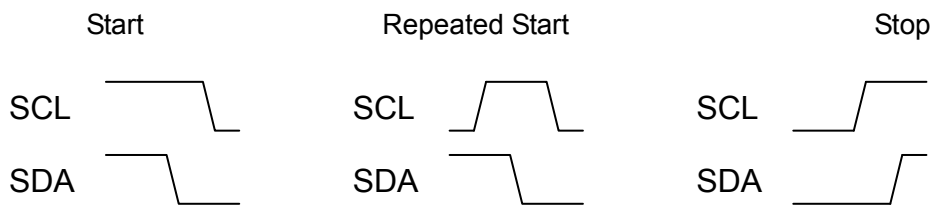

The I<sup>2</sup>C start, repeated start and stop conditions.

For detailed information such as timing, refer to the I<sup>2</sup>C specifications.

## • 8Bit Write

8Bit data is sent from the master microcomputer to LV25500.

For data bit, MSB first, LSB last.

Data transmission is synchronized with the SCL clock generated by the master IC. It is latched on the rising edge of SCL.

Data should not be changed while SCL is HIGH.

LV25500 outputs an ACK bit during the 8<sup>th</sup> and 9<sup>th</sup> of the falling edge of SCL.

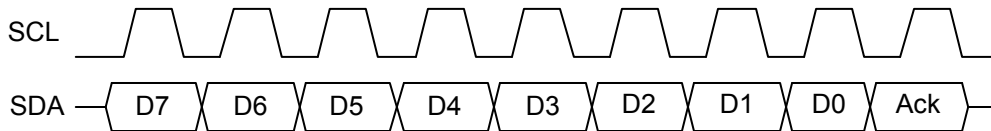

Signal pattern of the I<sup>2</sup>C byte write

## • 8Bit Read

Read is similar with Write format but data direction is opposite.

8Bit data is sent from LV25500 to the master, and ACK is sent from the master to the LV25500.

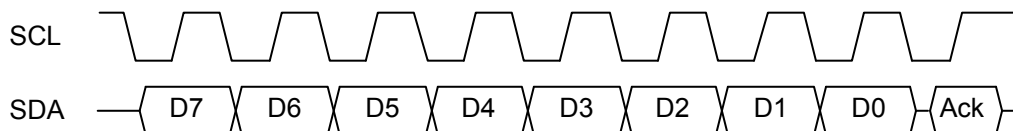

Signal pattern of the I<sup>2</sup>C byte read

Serial clock SCL will be provided by the master side.

Data bits which are out from the LV25500 are synchronized with the falling edge. And the master side should latch the data bits on the rising edge.

LV25500 latches the ACK on the rising edge.

The following is the sequence that writes data D to the LV25500 register A. (In case of PULL DOWN)

**• Write Sequence**

- Start condition confirmation
- Write device address(C0h)
- Write address information A
- Write Data D
- Stop condition

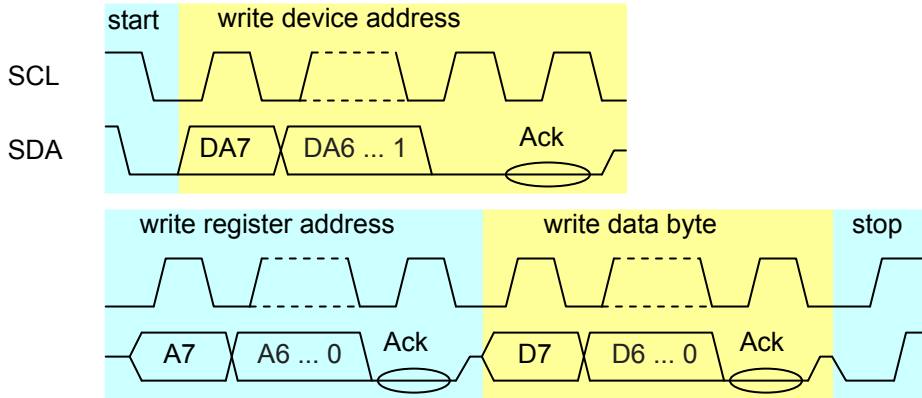

Register write through I<sup>2</sup>C

If more than one data was written, only the first data will be written.

**• Read Sequence**

- Start condition confirmation
- Write device address (C0h)
- Write address information A
- Repeated start condition (Or, stop + start sequence by the master)
- Write device address +1 (C1h)
- Read Register information D and send NACK (no more data to be read)
- Stop condition

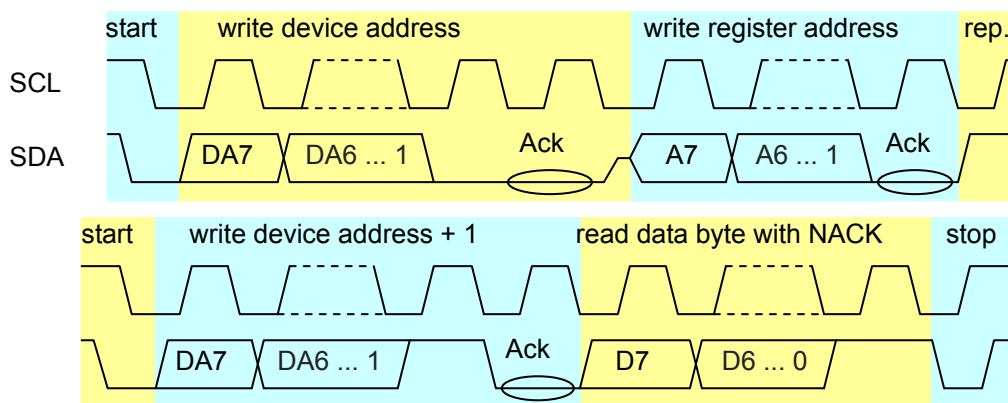

Register read through I<sup>2</sup>C

# LV25500PQA



## ORDERING INFORMATION

| Device        | Package                                      | Shipping (Qty / Packing) |
|---------------|--|--------------------------|
| LV25500PQA-NH | WQFN56 7x7, 0.4P<br>(Pb-Free / Halogen Free) | 2500 / Tape & Reel       |

ON Semiconductor and the ON logo are registered trademarks of Semiconductor Components Industries, LLC (SCILLC) or its subsidiaries in the United States and/or other countries. SCILLC owns the rights to a number of patents, trademarks, copyrights, trade secrets, and other intellectual property. A listing of SCILLC's product/patent coverage may be accessed at [www.onsemi.com/site/pdf/Patent-Marking.pdf](http://www.onsemi.com/site/pdf/Patent-Marking.pdf). SCILLC reserves the right to make changes without further notice to any products herein. SCILLC makes no warranty, representation or guarantee regarding the suitability of its products for any particular purpose, nor does SCILLC assume any liability arising out of the application or use of any product or circuit, and specifically disclaims any and all liability, including without limitation special, consequential or incidental damages. "Typical" parameters which may be provided in SCILLC data sheets and/or specifications can and do vary in different applications and actual performance may vary over time. All operating parameters, including "Typicals" must be validated for each customer application by customer's technical experts. SCILLC does not convey any license under its patent rights nor the rights of others. SCILLC products are not designed, intended, or authorized for use as components in systems intended for surgical implant into the body, or other applications intended to support or sustain life, or for any other application in which the failure of the SCILLC product could create a situation where personal injury or death may occur. Should Buyer purchase or use SCILLC products for any such unintended or unauthorized application, Buyer shall indemnify and hold SCILLC and its officers, employees, subsidiaries, affiliates, and distributors harmless against all claims, costs, damages, and expenses, and reasonable attorney fees arising out of, directly or indirectly, any claim of personal injury or death associated with such unintended or unauthorized use, even if such claim alleges that SCILLC was negligent regarding the design or manufacture of the part. SCILLC is an Equal Opportunity/Affirmative Action Employer. This literature is subject to all applicable copyright laws and is not for resale in any manner.

## Looking for pricing, stock, or lifecycle information?

Click below to explore more details on WIN SOURCE:

-  [View LV25500PQA-NH on WIN SOURCE](#)
-  [ON Semiconductor](#) Information

## Optimize Your Supply Chain with WIN SOURCE Solutions

-  Global Sourcing Solution
-  Obsolete Management
-  Cost Control Management
-  Shortage Management
-  Alternative Solution
-  Excess Inventory Management