



**THE DATASHEET OF
LTC6800HDD#PBF**



Rail-to-Rail, Input and Output, Instrumentation Amplifier

FEATURES

- **116dB CMRR Independent of Gain**
- **Maximum Offset Voltage: 100 μ V**
- **Maximum Offset Voltage Drift: 250nV/ $^{\circ}$ C**
- **-40 $^{\circ}$ C to 125 $^{\circ}$ C Operation**
- Rail-to-Rail Input Range
- Rail-to-Rail Output Swing
- Supply Operation: 2.7V to 5.5V
- Available in MS8 and 3mm \times 3mm \times 0.8mm DFN Packages

APPLICATIONS

- Thermocouple Amplifiers
- Electronic Scales
- Medical Instrumentation
- Strain Gauge Amplifiers
- High Resolution Data Acquisition

DESCRIPTION

The LTC[®]6800 is a precision instrumentation amplifier. The CMRR is typically 116dB with a single 5V supply and is independent of gain. The input offset voltage is guaranteed below 100 μ V with a temperature drift of less than 250nV/ $^{\circ}$ C. The LTC6800 is easy to use; the gain is adjustable with two external resistors, like a traditional op amp.

The LTC6800 uses charge balanced sampled data techniques to convert a differential input voltage into a single ended signal that is in turn amplified by a zero-drift operational amplifier.

The differential inputs operate from rail-to-rail and the single ended output swings from rail-to-rail. The LTC6800 is available in an MS8 surface mount package. For space limited applications, the LTC6800 is available in a 3mm \times 3mm \times 0.8mm dual fine pitch leadless package (DFN).

LT, LT, LTC, LTM, Linear Technology and the Linear logo are registered trademarks of Linear Technology Corporation. All other trademarks are the property of their respective owners.

TYPICAL APPLICATION

High Side Power Supply Current Sense

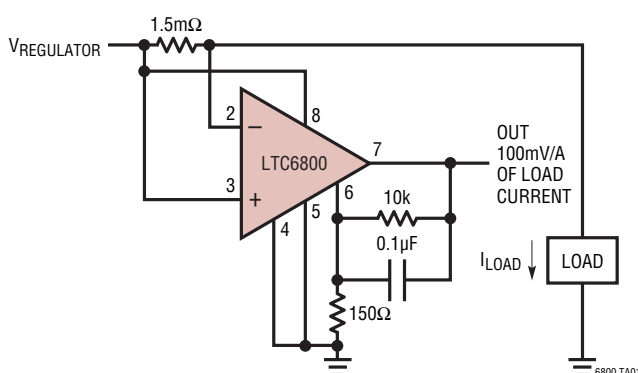

Typical Input Referred Offset vs Input Common Mode Voltage ($V_S = 3V$)

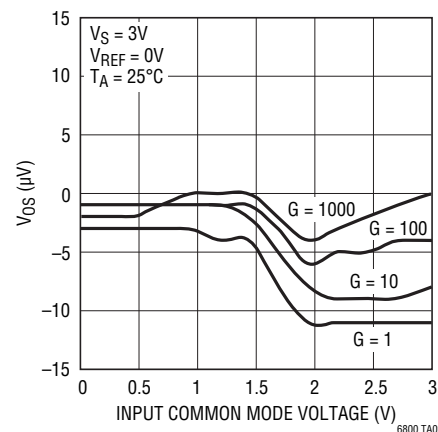

LTC6800

ABSOLUTE MAXIMUM RATINGS (Note 1)

Total Supply Voltage (V^+ to V^-)	5.5V	Storage Temperature Range	
Input Current.....	$\pm 10\text{mA}$	DD Package	-65°C to 125°C
$ V_{+IN} - V_{REF} $	5.5V	MS8 Package.....	-65°C to 150°C
$ V_{-IN} - V_{REF} $	5.5V	Lead Temperature (Soldering, 10 sec).....	300°C
Output Short-Circuit Duration.....	Indefinite		
Operating Temperature Range			
(Note 7).....	-40°C to 125°C		

PIN CONFIGURATION

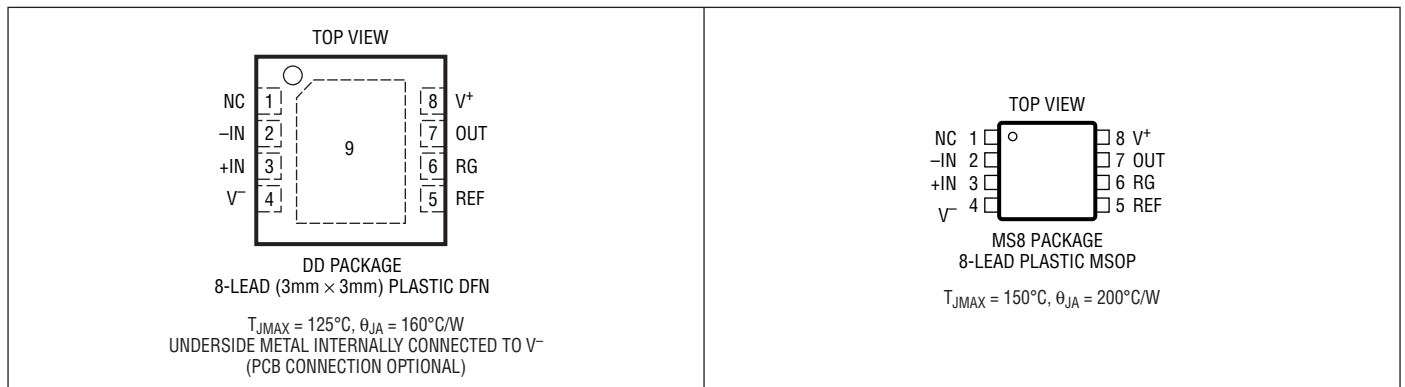

ORDER INFORMATION

LEAD FREE FINISH	TAPE AND REEL	PART MARKING*	PACKAGE DESCRIPTION	TEMPERATURE RANGE
LTC6800HDD#PBF	LTC6800HDD#TRPBF	LAEP	8-Lead (3mm × 3mm) Plastic DFN	-40°C to 125°C
LTC6800HMS8#PBF	LTC6800HMS8#TRPBF	LTAE	8-Lead Plastic MSOP	-40°C to 125°C

Consult LTC Marketing for parts specified with wider operating temperature ranges.

Consult LTC Marketing for information on non-standard lead based finish parts.

For more information on lead free part marking, go to: <http://www.linear.com/leadfree/>

For more information on tape and reel specifications, go to: <http://www.linear.com/tapeandreeel/>

ELECTRICAL CHARACTERISTICS The ● denotes the specifications which apply over the full operating temperature range, otherwise specifications are at $T_A = 25^\circ\text{C}$. $V^+ = 3\text{V}$, $V^- = 0\text{V}$, $\text{REF} = 200\text{mV}$. Output voltage swing is referenced to V^- . All other specifications reference the OUT pin to the REF pin.

PARAMETER	CONDITIONS		MIN	TYP	MAX	UNITS
Input Offset Voltage (Note 2)	$V_{\text{CM}} = 200\text{mV}$				± 100	μV
Average Input Offset Drift (Note 2)	$T_A = -40^\circ\text{C}$ to 85°C $T_A = 85^\circ\text{C}$ to 125°C	● ●		-1	± 250 -2.5	$\text{nV}/^\circ\text{C}$ $\mu\text{V}/^\circ\text{C}$
Common Mode Rejection Ratio (Notes 4, 5)	$A_V = 1$, $V_{\text{CM}} = 0\text{V}$ to 3V	●	85	113		dB
Integrated Input Bias Current (Note 3)	$V_{\text{CM}} = 1.2\text{V}$			4	10	nA
Integrated Input Offset Current (Note 3)	$V_{\text{CM}} = 1.2\text{V}$			1	3	nA
Input Noise Voltage	DC to 10Hz			2.5		$\mu\text{V}_{\text{P-P}}$
Power Supply Rejection Ratio (Note 6)	$V_S = 2.7\text{V}$ to 5.5V	●	110	116		dB
Output Voltage Swing High	$R_L = 2\text{k}$ to V^- $R_L = 10\text{k}$ to V^-	● ●	2.85 2.95	2.94 2.98		V V
Output Voltage Swing Low		●			20	mV
Gain Error	$A_V = 1$				0.1	%
Gain Nonlinearity	$A_V = 1$				100	ppm
Supply Current	No Load	●			1.2	mA
Internal Op Amp Gain Bandwidth				200		kHz
Slew Rate				0.2		$\text{V}/\mu\text{s}$
Internal Sampling Frequency				3		kHz

The ● denotes the specifications which apply over the full operating temperature range, otherwise specifications are at $T_A = 25^\circ\text{C}$. $V^+ = 5\text{V}$, $V^- = 0\text{V}$, $\text{REF} = 200\text{mV}$. Output voltage swing is referenced to V^- . All other specifications reference the OUT pin to the REF pin.

PARAMETER	CONDITIONS		MIN	TYP	MAX	UNITS
Input Offset Voltage (Note 2)	$V_{\text{CM}} = 200\text{mV}$				± 100	μV
Average Input Offset Drift (Note 2)	$T_A = -40^\circ\text{C}$ to 85°C $T_A = 85^\circ\text{C}$ to 125°C	● ●		-1	± 250 -2.5	$\text{nV}/^\circ\text{C}$ $\mu\text{V}/^\circ\text{C}$
Common Mode Rejection Ratio (Notes 4, 5)	$A_V = 1$, $V_{\text{CM}} = 0\text{V}$ to 5V	●	85	116		dB
Integrated Input Bias Current (Note 3)	$V_{\text{CM}} = 1.2\text{V}$			4	10	nA
Integrated Input Offset Current (Note 3)	$V_{\text{CM}} = 1.2\text{V}$			1	3	nA
Power Supply Rejection Ratio (Note 6)	$V_S = 2.7\text{V}$ to 5.5V	●	110	116		dB
Output Voltage Swing High	$R_L = 2\text{k}$ to V^- $R_L = 10\text{k}$ to V^-	● ●	4.85 4.95	4.94 4.98		V V
Output Voltage Swing Low		●			20	mV
Gain Error	$A_V = 1$				0.1	%
Gain Nonlinearity	$A_V = 1$				100	ppm
Supply Current	No Load	●			1.3	mA
Internal Op Amp Gain Bandwidth				200		kHz
Slew Rate				0.2		$\text{V}/\mu\text{s}$
Internal Sampling Frequency				3		kHz

Note 1: Stresses beyond those listed under Absolute Maximum Ratings may cause permanent damage to the device. Exposure to any Absolute Maximum Rating condition for extended periods may affect device reliability and lifetime.

Note 2: These parameters are guaranteed by design. Thermocouple effects preclude measurement of these voltage levels in high speed automatic test systems. V_{OS} is measured to a limit determined by test equipment capability.

ELECTRICAL CHARACTERISTICS

Note 3: If the total source resistance is less than 10k, no DC errors result from the input bias currents or the mismatch of the input bias currents or the mismatch of the resistances connected to -IN and +IN.

Note 4: The CMRR with a voltage gain, A_V , larger than 10 is 120dB (typ).

Note 5: At temperatures above 70°C, the common mode rejection ratio lowers when the common mode input voltage is within 100mV of the supply rails.

Note 6: The power supply rejection ratio (PSRR) measurement accuracy depends on the proximity of the power supply bypass capacitor to the device under test. Because of this, the PSRR is 100% tested to relaxed limits at final test. However, their values are guaranteed by design to meet the data sheet limits.

Note 7: The LTC6800H is guaranteed functional over the operating temperature range of -40°C to 125°C. Specifications over the -40°C to 125°C range (denoted by ●) are assured by design and characterization but are not tested or QA sampled at these temperatures.

TYPICAL PERFORMANCE CHARACTERISTICS

Input Offset Voltage vs Input Common Mode Voltage

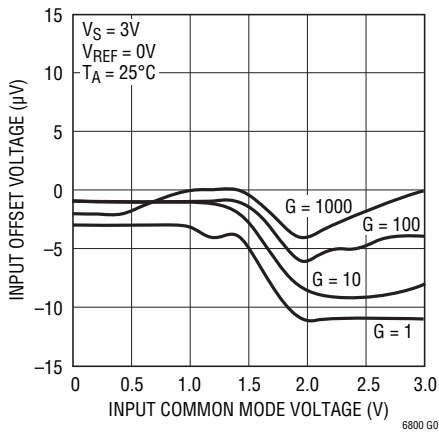

Input Offset Voltage vs Input Common Mode Voltage

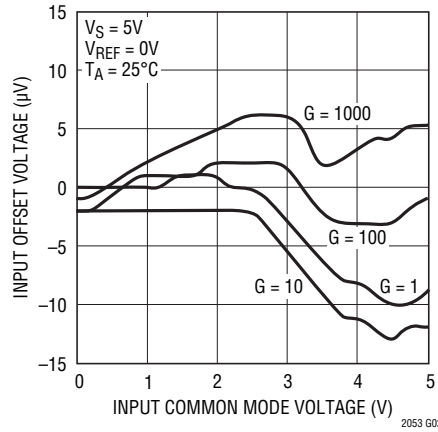

Input Offset Voltage vs Input Common Mode Voltage

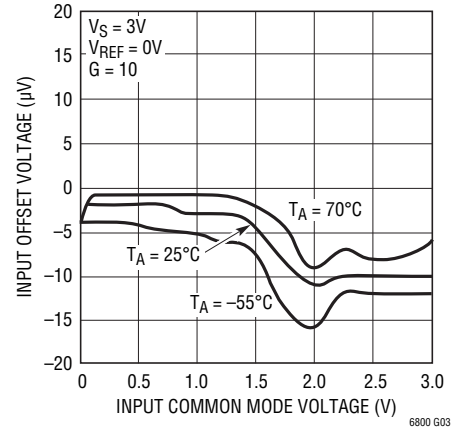

Input Offset Voltage vs Input Common Mode Voltage

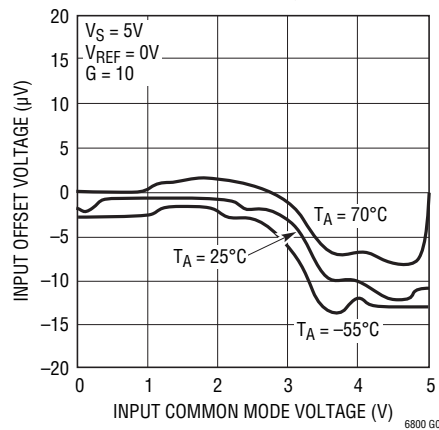

Input Offset Voltage vs Input Common Mode Voltage, 85°C ≤ TA ≤ 125°C

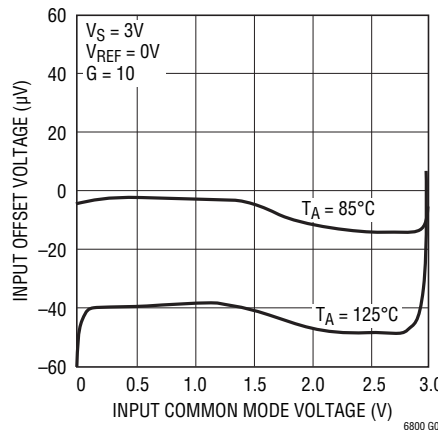

Input Offset Voltage vs Input Common Mode Voltage, 85°C ≤ TA ≤ 125°C

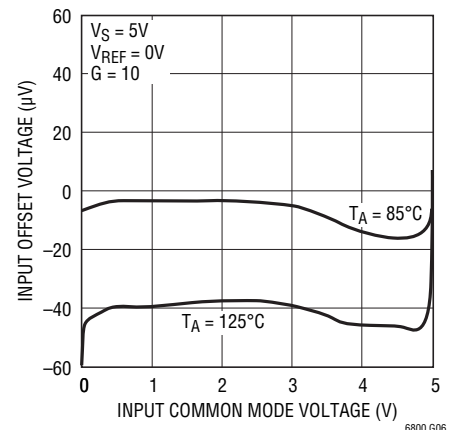

TYPICAL PERFORMANCE CHARACTERISTICS

Additional Input Offset Due to Input R_S vs Input Common Mode ($C_{IN} < 100pF$)

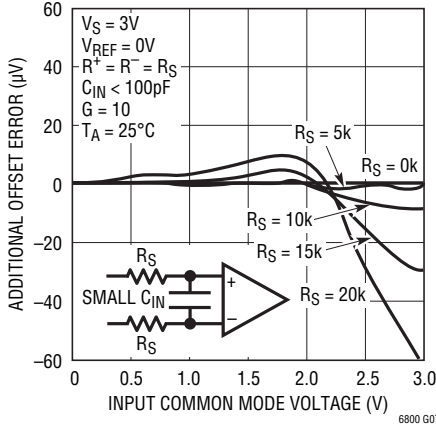

Additional Input Offset Due to Input R_S vs Input Common Mode ($C_{IN} < 100pF$)

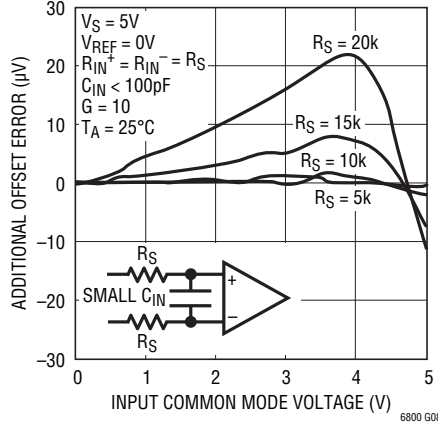

Additional Input Offset Due to Input R_S Mismatch vs Input Common Mode ($C_{IN} < 100pF$)

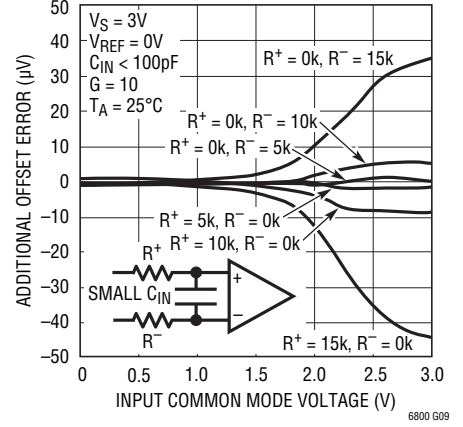

Additional Input Offset Due to Input R_S Mismatch vs Input Common Mode ($C_{IN} < 100pF$)

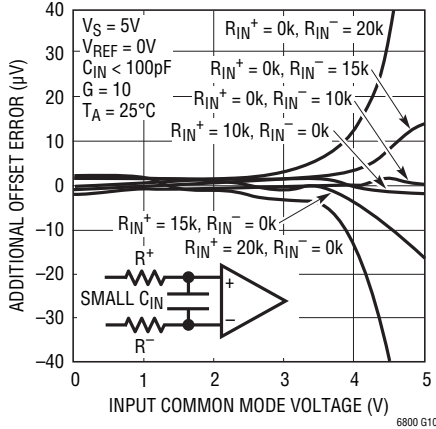

Additional Input Offset Due to Input R_S vs Input Common Mode ($C_{IN} > 1\mu F$)

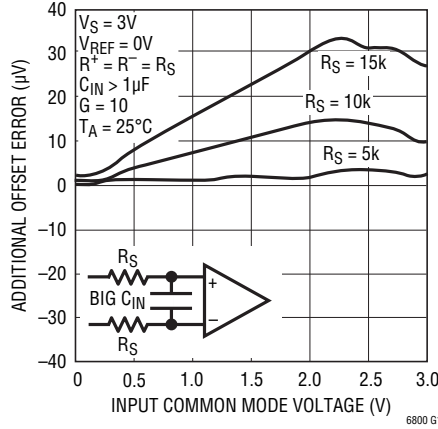

Additional Input Offset Due to Input R_S vs Input Common Mode ($C_{IN} > 1\mu F$)

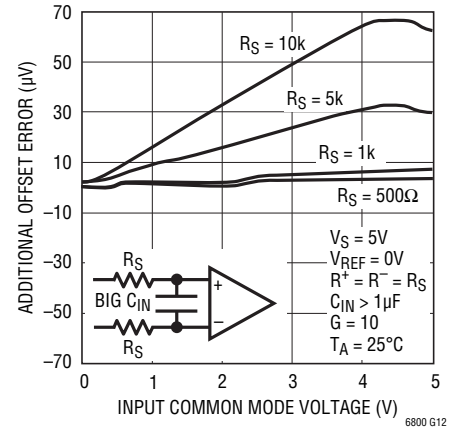

Additional Input Offset Due to Input R_S Mismatch vs Input Common Mode ($C_{IN} > 1\mu F$)

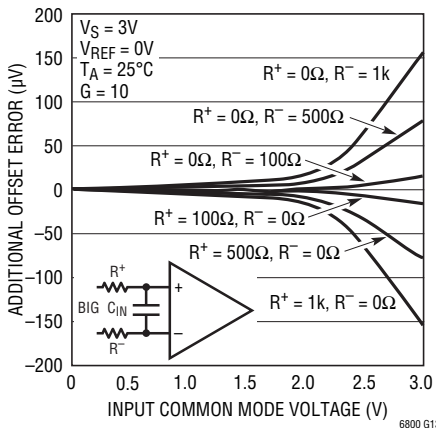

Additional Input Offset Due to Input R_S Mismatch vs Input Common Mode ($C_{IN} > 1\mu F$)

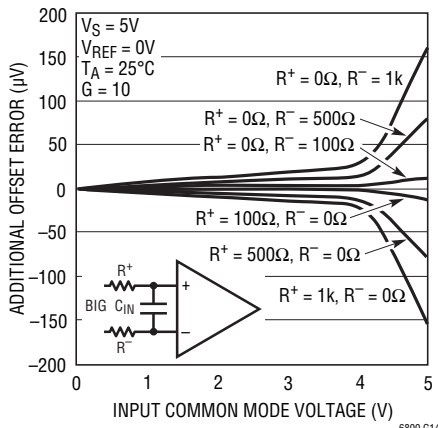

Offset Voltage vs Temperature

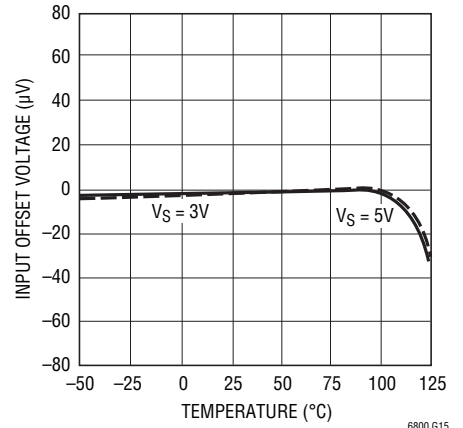

TYPICAL PERFORMANCE CHARACTERISTICS

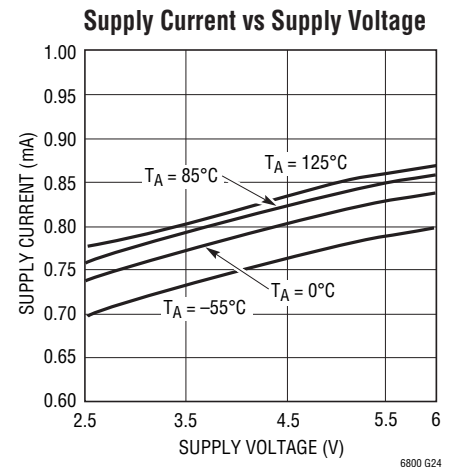
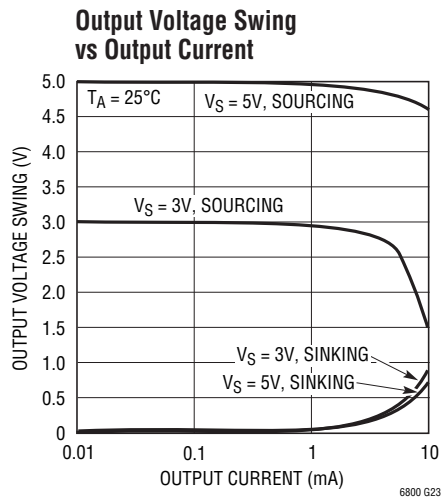
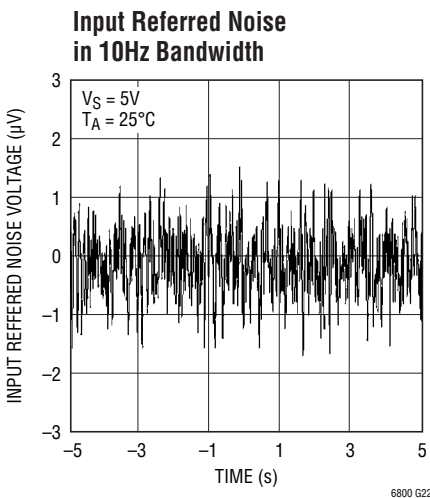
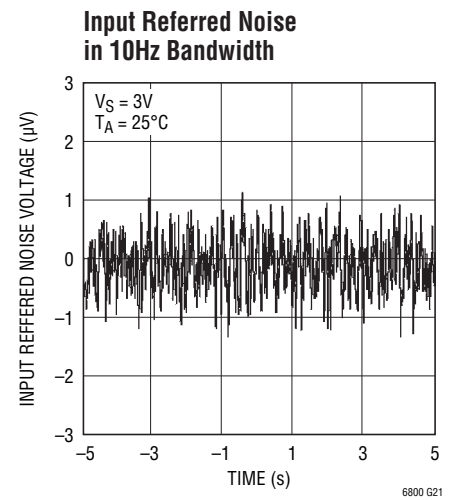
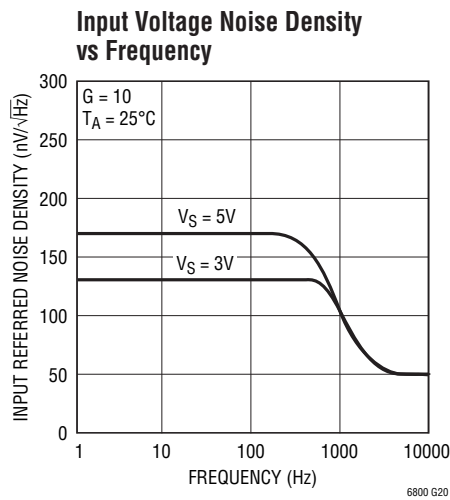
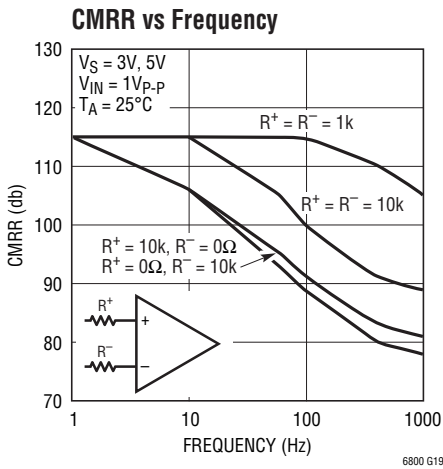
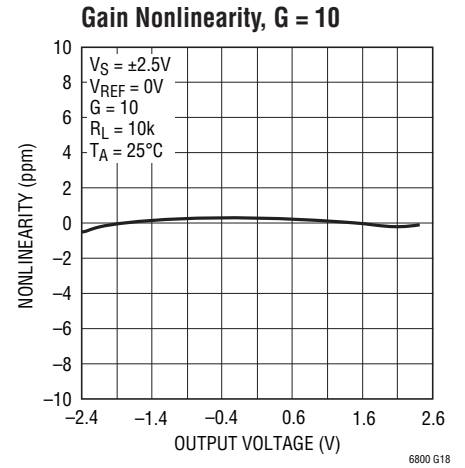
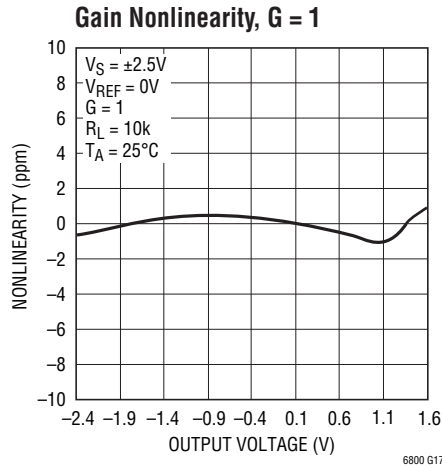
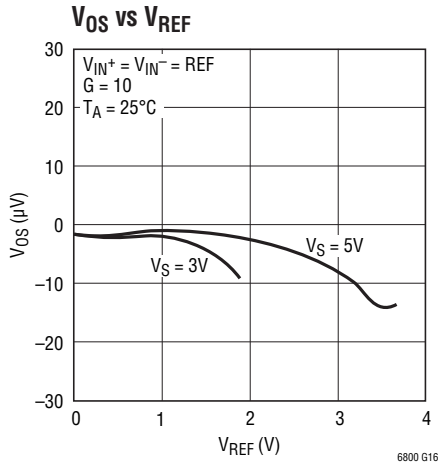

TYPICAL PERFORMANCE CHARACTERISTICS

Low Gain Settling Time vs Settling Accuracy

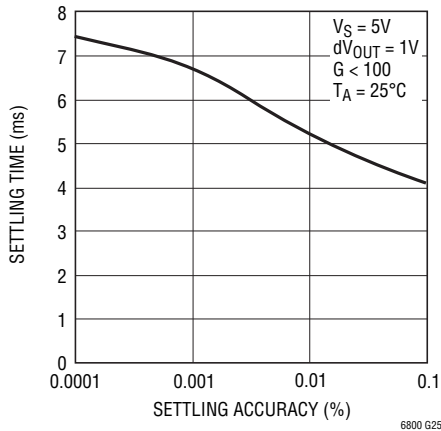

Settling Time vs Gain

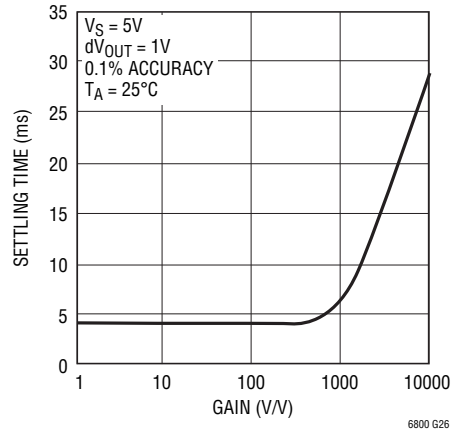

Internal Clock Frequency vs Supply Voltage

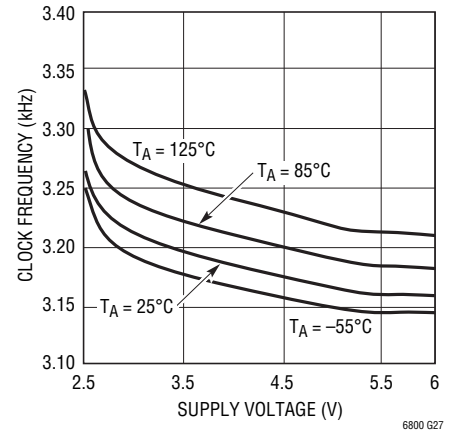

PIN FUNCTIONS

NC (Pin 1): Not Connected.

-IN (Pin 2): Inverting Input.

+IN (Pin 3): Noninverting Input.

V^- (Pin 4): Negative Supply.

REF (Pin 5): Voltage Reference (V_{REF}) for Amplifier Output.

RG (Pin 6): Inverting Input of Internal Op Amp. See Figure 1.

OUT (Pin 7): Amplifier Output. See Figure 1.

V^+ (Pin 8): Positive Supply.

BLOCK DIAGRAM

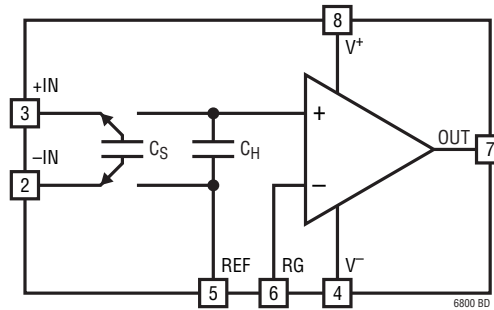

APPLICATIONS INFORMATION

Theory of Operation

The LTC6800 uses an internal capacitor (C_S) to sample a differential input signal riding on a DC common mode voltage (see the Block Diagram). This capacitor's charge is transferred to a second internal hold capacitor (C_H) translating the common mode of the input differential signal to that of the REF pin. The resulting signal is amplified by a zero-drift op amp in the noninverting configuration. The RG pin is the negative input of this op amp and allows external programmability of the DC gain. Simple filtering can be realized by using an external capacitor across the feedback resistor.

Input Voltage Range

The input common mode voltage range of the LTC6800 is rail-to-rail. However, the following equation limits the size of the differential input voltage:

$$V^- \leq (V_{+IN} - V_{-IN}) + V_{REF} \leq V^+ - 1.3$$

Where V_{+IN} and V_{-IN} are the voltages of the +IN and -IN pins, respectively, V_{REF} is the voltage at the REF pin and V^+ is the positive supply voltage.

For example, with a 3V single supply and a 0V to 100mV differential input voltage, V_{REF} must be between 0V and 1.6V.

Settling Time

The sampling rate is 3kHz and the input sampling period during which C_S is charged to the input differential voltage V_{IN} is approximately 150 μ s. First assume that on each input sampling period, C_S is charged fully to V_{IN} . Since $C_S = C_H (= 1000\text{pF})$, a change in the input will settle to N bits of accuracy at the op amp noninverting input after N clock cycles or 333 μ s(N). The settling time at the OUT pin is also affected by the settling of the internal op amp. Since the gain bandwidth of the internal op amp is typically 200kHz, the settling time is dominated by the switched capacitor front end for gains below 100 (see the Typical Performance Characteristics section).

APPLICATIONS INFORMATION

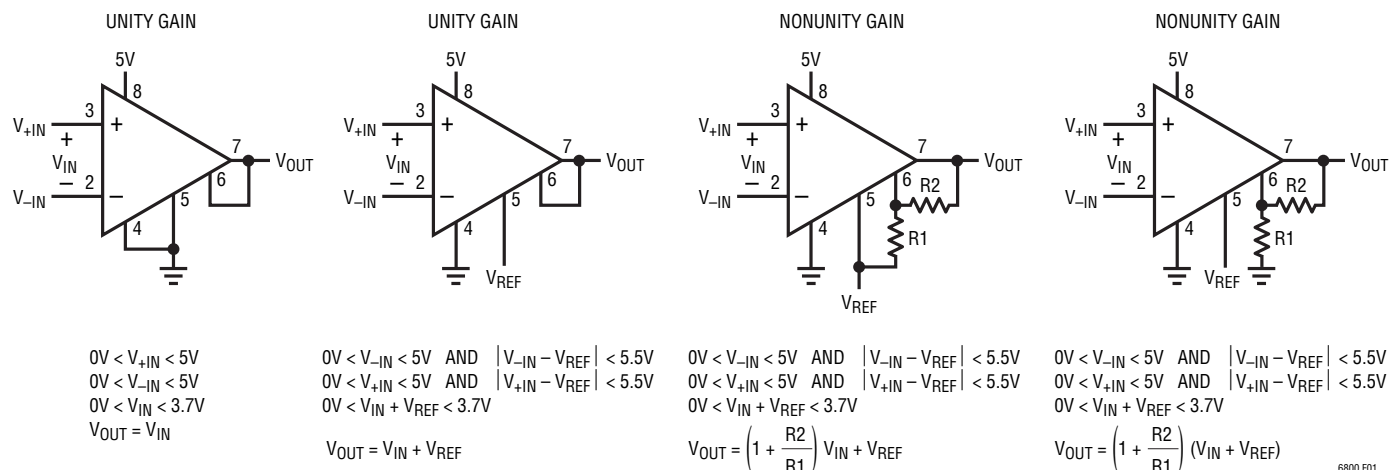

Figure 1

Input Current

Whenever the differential input V_{IN} changes, C_H must be charged up to the new input voltage via C_S . This results in an input charging current during each input sampling period. Eventually, C_H and C_S will reach V_{IN} and, ideally, the input current would go to zero for DC inputs.

In reality, there are additional parasitic capacitors which disturb the charge on C_S every cycle even if V_{IN} is a DC voltage. For example, the parasitic bottom plate capacitor on C_S must be charged from the voltage on the REF pin to the voltage on the $-IN$ pin every cycle. The resulting input charging current decays exponentially during each input sampling period with a time constant equal to $R_S C_S$. **If the voltage disturbance due to these currents settles before the end of the sampling period, there will be no errors due to source resistance or the source resistance mismatch between $-IN$ and $+IN$. With R_S less than 10k, no DC errors occur due to this input current.**

In the Typical Performance Characteristics section of this data sheet, there are curves showing the additional error from nonzero source resistance in the inputs. If there are no large capacitors across the inputs, the amplifier is less sensitive to source resistance and source resistance mismatch. When large capacitors are placed across the inputs, the input charging currents previously described result in larger DC errors, especially with source resistor mismatches.

Power Supply Bypassing

The LTC6800 uses a sampled data technique and, therefore, contains some clocked digital circuitry. It is, therefore, sensitive to supply bypassing. A 0.1 μ F ceramic capacitor must be connected between Pin 8 (V^+) and Pin 4 (V^-) with leads as short as possible.

TYPICAL APPLICATIONS

Precision $\div 2$

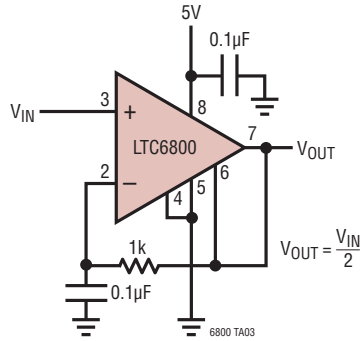

Precision Doubler (General Purpose)

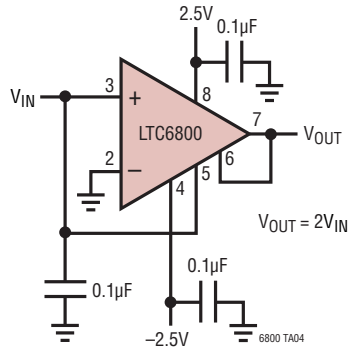

Precision Inversion (General Purpose)

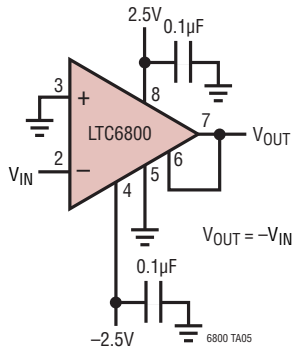

PACKAGE DESCRIPTION

MS8 Package
8-Lead Plastic MSOP
 (Reference LTC DWG # 05-08-1660 Rev F)

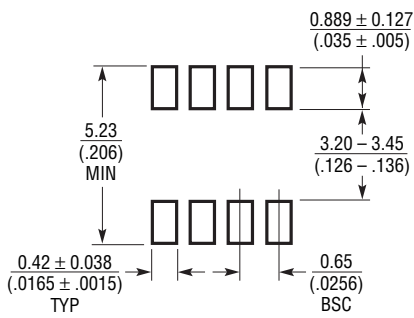

RECOMMENDED SOLDER PAD LAYOUT

NOTE:

1. DIMENSIONS IN MILLIMETER/(INCH)
2. DRAWING NOT TO SCALE
3. DIMENSION DOES NOT INCLUDE MOLD FLASH, PROTRUSIONS OR GATE BURRS. MOLD FLASH, PROTRUSIONS OR GATE BURRS SHALL NOT EXCEED 0.152mm (.006") PER SIDE
4. DIMENSION DOES NOT INCLUDE INTERLEAD FLASH OR PROTRUSIONS. INTERLEAD FLASH OR PROTRUSIONS SHALL NOT EXCEED 0.152mm (.006") PER SIDE
5. LEAD COPLANARITY (BOTTOM OF LEADS AFTER FORMING) SHALL BE 0.102mm (.004") MAX

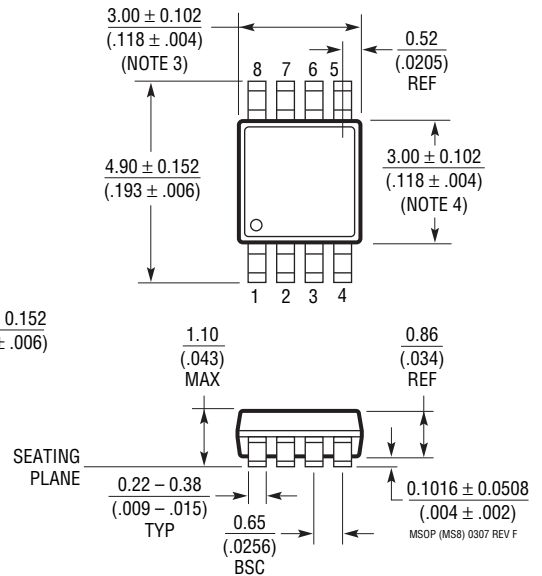
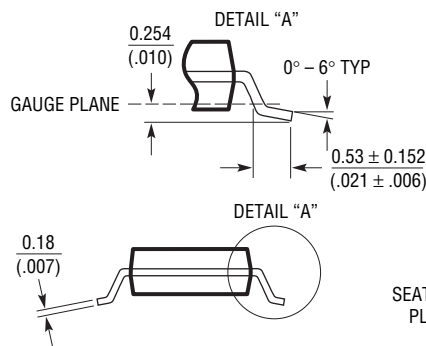

REVISION HISTORY (Revision history begins at Rev B)

REV	DATE	DESCRIPTION	PAGE NUMBER
B	7/10	Corrected text in the Absolute Maximum Ratings section	2
		Updated Pin 6 and Pin 7 text in the Pin Functions section	7
		Replaced Figure 1	9

TYPICAL APPLICATION

Differential Bridge Amplifier

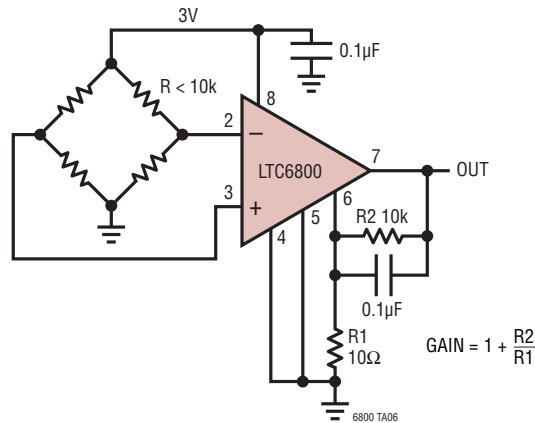

RELATED PARTS

PART NUMBER	DESCRIPTION	COMMENTS
LTC1100	Precision Zero-Drift Instrumentation Amplifier	Fixed Gains of 10 or 100, 10µV Offset, 50pA Input Bias Current
LT [®] 1101	Precision, Micropower, Single Supply Instrumentation Amplifier	Fixed Gains of 10 or 100, I _S < 105µA
LT1167	Single Resistor, Gain-Programmable, Precision Instrumentation Amplifier	Single-Gain Set Resistor: G = 1 to 10,000, Low Noise: 7.5nV√Hz
LT1168	Low Power, Single Resistor, Gain-Programmable, Precision Instrumentation Amplifier	I _{SUPPLY} = 530µA
LTC1043	Dual Precision Instrumentation Switched-Capacitor Building Block	Rail-to-Rail Input, 120dB CMRR
LT1789-1	Single Supply, Rail-to-Rail Output, Micropower Instrumentation Amplifier	I _{SUPPLY} = 80µA Maximum
LTC2050	Zero-Drift Operational Amplifier	SOT-23 Package, 3µV Max V _{OS} , 30nV/°C Max Drift
LTC2051	Dual Zero-Drift Operational Amplifier	MS8 Package, 3µV Max V _{OS} , 30nV/°C Max Drift
LTC2052	Quad Zero-Drift Operational Amplifier	GN-16 Package, 3µV Max V _{OS} , 30nV/°C Max Drift
LTC2053	Single Supply, Zero-Drift, Rail-to-Rail Input and Output Instrumentation Amplifier	MS8 Package, 10µV Max V _{OS} , 50nV/°C Max Drift

Looking for pricing, stock, or lifecycle information?

Click below to explore more details on WIN SOURCE:

 [View LTC6800HDD#PBF on WIN SOURCE](#)

 [Linear Technology](#) Information

Optimize Your Supply Chain with WIN SOURCE Solutions

-  Global Sourcing Solution
-  Obsolete Management
-  Cost Control Management
-  Shortage Management
-  Alternative Solution
-  Excess Inventory Management