



**THE DATASHEET OF  
LTC6400CUD-20#PBF**



# 1.8GHz Low Noise, Low Distortion Differential ADC Driver for 300MHz IF

## FEATURES

- 1.8GHz –3dB Bandwidth
- Fixed Gain of 10V/V (20dB)
- –94dBc IMD<sub>3</sub> at 70MHz (Equivalent OIP3 = 51dBm)
- –65dBc IMD<sub>3</sub> at 300MHz (Equivalent OIP3 = 36.5dBm)
- 1nV/√Hz Internal Op Amp Noise
- 2.1nV/√Hz Total Input Noise
- 6.2dB Noise Figure
- Differential Inputs and Outputs
- 200Ω Input Impedance
- 2.85V to 3.5V Supply Voltage
- 90mA Supply Current (270mW)
- 1V to 1.6V Output Common Mode Voltage, Adjustable
- DC- or AC-Coupled Operation
- Max Differential Output Swing 4.4V<sub>P-P</sub>
- Small 16-Lead 3mm × 3mm × 0.75mm QFN Package

## APPLICATIONS

- Differential ADC Driver
- Differential Driver/Receiver
- Single Ended to Differential Conversion
- IF Sampling Receivers
- SAW Filter Interfacing

## DESCRIPTION

The LTC®6400-20 is a high-speed differential amplifier targeted at processing signals from DC to 300MHz. The part has been specifically designed to drive 12-, 14- and 16-bit ADCs with low noise and low distortion, but can also be used as a general-purpose broadband gain block.

The LTC6400-20 is easy to use, with minimal support circuitry required. The output common mode voltage is set using an external pin, independent of the inputs, which eliminates the need for transformers or AC-coupling capacitors in many applications. The gain is internally fixed at 20dB (10V/V).

The LTC6400-20 saves space and power compared to alternative solutions using IF gain blocks and transformers. The LTC6400-20 is packaged in a compact 16-lead 3mm × 3mm QFN package and operates over the –40°C to 85°C temperature range.

*LT*, *LT*, *LTC* and *LTM* are registered trademarks of Linear Technology Corporation. All other trademarks are the property of their respective owners.

## TYPICAL APPLICATION

Single-Ended to Differential ADC Driver

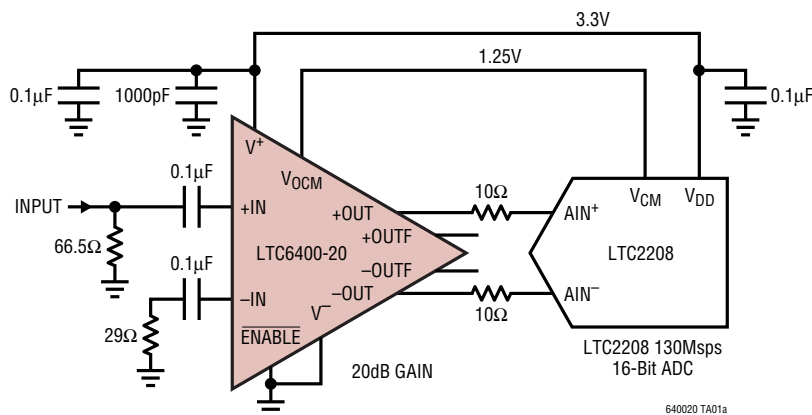

Equivalent Output IP3 vs Frequency

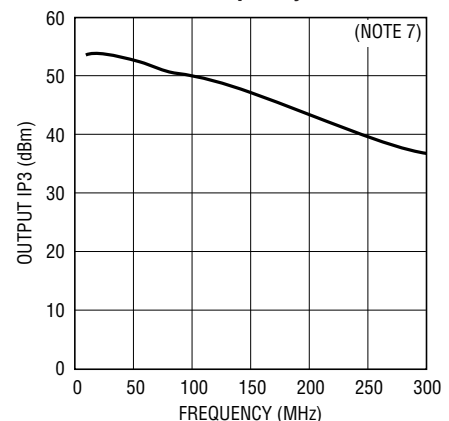

# LTC6400-20

## ABSOLUTE MAXIMUM RATINGS

(Note 1)

Supply Voltage ( $V^+ - V^-$ ).....	3.6V
Input Current (Note 2).....	$\pm 10\text{mA}$
Operating Temperature Range (Note 3) .....	$-40^\circ\text{C}$ to $85^\circ\text{C}$
Specified Temperature Range (Note 4) .....	$-40^\circ\text{C}$ to $85^\circ\text{C}$
Storage Temperature Range.....	$-65^\circ\text{C}$ to $150^\circ\text{C}$
Maximum Junction Temperature .....	$150^\circ\text{C}$
Lead Temperature (Soldering, 10 sec) .....	$300^\circ\text{C}$

## PIN CONFIGURATION

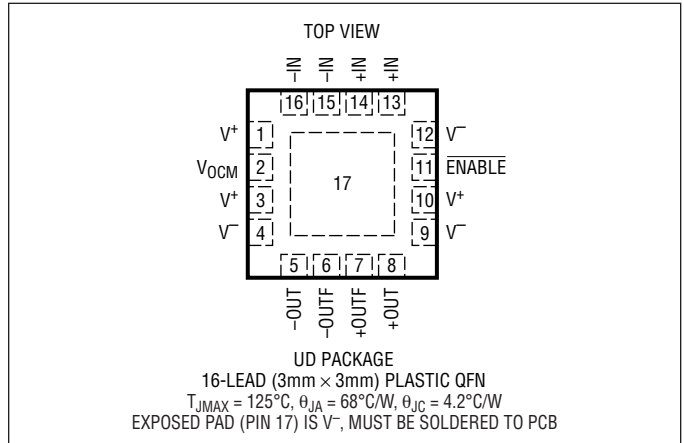

## ORDER INFORMATION

LEAD FREE FINISH	TAPE AND REEL	PART MARKING*	PACKAGE DESCRIPTION	TEMPERATURE RANGE
LTC6400CUD-20#PBF	LTC6400CUD-20#TRPBF	LCCS	16-Lead (3mm × 3mm) Plastic QFN	$0^\circ\text{C}$ to $70^\circ\text{C}$
LTC6400IUD-20#PBF	LTC6400IUD-20#TRPBF	LCCS	16-Lead (3mm × 3mm) Plastic QFN	$-40^\circ\text{C}$ to $85^\circ\text{C}$

Consult LTC Marketing for parts specified with wider operating temperature ranges. \*The temperature grade is identified by a label on the shipping container. Consult LTC Marketing for information on non-standard lead based finish parts.

For more information on lead free part marking, go to: <http://www.linear.com/leadfree/>

For more information on tape and reel specifications, go to: <http://www.linear.com/tapeandreeel/>

## LTC6400 AND LTC6401 SELECTOR GUIDE Please check each datasheet for complete details.

PART NUMBER	GAIN (dB)	GAIN (V/V)	$Z_{IN}$ (DIFFERENTIAL) ( $\Omega$ )	$I_S$ (mA)
LTC6400-20	20	10	200	90
LTC6401-20	20	10	200	50

In addition to the LTC6400 family of amplifiers, a lower power LTC6401 family is available. The LTC6401 is pin compatible to the LTC6400, and has the same low noise performance. The lower power consumption of the LTC6401 comes at the expense of slightly higher non-linearity, especially at input frequencies above 140MHz. Please refer to the separate LTC6401 data sheets for complete details. Other gain versions from 8dB to 26dB will follow.

**DC ELECTRICAL CHARACTERISTICS** The ● denotes the specifications which apply over the full operating temperature range, otherwise specifications are at  $T_A = 25^\circ\text{C}$ .  $V^+ = 3\text{V}$ ,  $V^- = 0\text{V}$ ,  $+IN = -IN = V_{OCM} = 1.25\text{V}$ ,  $\text{ENABLE} = 0\text{V}$ , No  $R_L$  unless otherwise noted.

SYMBOL	PARAMETER	CONDITIONS		MIN	TYP	MAX	UNITS
<b>Input/Output Characteristic</b>							
$G_{DIFF}$	Gain	$V_{IN} = \pm 100\text{mV}$ Differential	●	19.4	20	20.6	dB
$TC_{GAIN}$	Gain Temperature Drift	$V_{IN} = \pm 100\text{mV}$ Differential	●		-1.5		mdB/ $^\circ\text{C}$
$V_{SWINGMIN}$	Output Swing Low	Each Output, $V_{IN} = \pm 600\text{mV}$ Differential	●		80	150	mV
$V_{SWINGMAX}$	Output Swing High	Each Output, $V_{IN} = \pm 600\text{mV}$ Differential	●	2.35	2.46		V
$V_{OUTDIFFMAX}$	Maximum Differential Output Swing	1dB Compressed	●		4.4		$V_{P-P}$
$I_{OUT}$	Output Current Drive	Each Output	●	20			mA
$V_{OSDIFF}$	Input Differential Offset Voltage		●	-2		2	mV
$TCV_{OSDIFF}$	Input Differential Offset Voltage Drift	$T_{MIN}$ to $T_{MAX}$	●		1.2		$\mu\text{V}/^\circ\text{C}$
$I_{VRMIN}$	Input Common Mode Voltage Range, MIN					1	V
$I_{VRMAX}$	Input Common Mode Voltage Range, MAX			1.6			V
$R_{INDIFF}$	Input Resistance (+IN, -IN)	Differential	●	170	200	230	$\Omega$
$C_{INDIFF}$	Input Capacitance (+IN, -IN)	Differential, Includes Parasitic			1		pF
$R_{OUTDIFF}$	Output Resistance (+OUT, -OUT)	Differential	●	18	25	32	$\Omega$
$R_{OUTFDIFF}$	Filtered Output Resistance (+OUTF, -OUTF)	Differential	●	85	100	115	$\Omega$
$C_{OUTFDIFF}$	Filtered Output Capacitance (+OUTF, -OUTF)	Differential, Includes Parasitic			2.7		pF
$CMRR$	Common Mode Rejection Ratio	Input Common Mode Voltage 1.1V~1.4V	●	45	65		dB
<b>Output Common Mode Voltage Control</b>							
$G_{CM}$	Common Mode Gain	$V_{OCM} = 1\text{V}$ to 1.6V			1		V/V
$V_{OCMMIN}$	Output Common Mode Range, MIN		●			1 1.1	V V
$V_{OCMMAX}$	Output Common Mode Range, MAX		●	1.6 1.5			V V
$V_{OSCM}$	Common Mode Offset Voltage	$V_{OCM} = 1.1\text{V}$ to 1.5V	●	-15		15	mV
$TCV_{OSCM}$	Common Mode Offset Voltage Drift	$T_{MIN}$ to $T_{MAX}$	●		16		$\mu\text{V}/^\circ\text{C}$
$I_{V_{OCM}}$	$V_{OCM}$ Input Current		●		5	15	$\mu\text{A}$
<b>ENABLE Pin</b>							
$V_{IL}$	$\overline{\text{ENABLE}}$ Input Low Voltage		●			0.8	V
$V_{IH}$	$\overline{\text{ENABLE}}$ Input High Voltage		●	2.4			V
$I_{IL}$	$\overline{\text{ENABLE}}$ Input Low Current	$\overline{\text{ENABLE}} = 0.8\text{V}$	●			0.5	$\mu\text{A}$
$I_{IH}$	$\overline{\text{ENABLE}}$ Input High Current	$\overline{\text{ENABLE}} = 2.4\text{V}$	●		1.2	3	$\mu\text{A}$
<b>Power Supply</b>							
$V_S$	Operating Supply Range		●	2.85	3	3.5	V
$I_S$	Supply Current	$\overline{\text{ENABLE}} = 0.8\text{V}$	●	75	90	105	mA
$I_{SHDN}$	Shutdown Supply Current	$\overline{\text{ENABLE}} = 2.4\text{V}$	●		1	3	mA
$PSRR$	Power Supply Rejection Ratio (Differential Outputs)	$V^+ = 2.85\text{V}$ to 3.5V	●	55	86		dB

**AC ELECTRICAL CHARACTERISTICS**Specifications are at  $T_A = 25^\circ\text{C}$ .  $V^+ = 3\text{V}$ ,  $V^- = 0\text{V}$ ,  $V_{\text{OCM}} = 1.25\text{V}$ ,ENABLE = 0V, No  $R_L$  unless otherwise noted.

SYMBOL	PARAMETER	CONDITIONS	MIN	TYP	MAX	UNITS
-3dB BW	-3dB Bandwidth	200mV <sub>P-P,OUT</sub> (Note 6)		1.84		GHz
0.1dB BW	Bandwidth for 0.1dB Flatness	200mV <sub>P-P,OUT</sub> (Note 6)		0.3		GHz
0.5dB BW	Bandwidth for 0.5dB Flatness	200mV <sub>P-P,OUT</sub> (Note 6)		0.7		GHz
1/f	1/f Noise Corner			10.5		kHz
SR	Slew Rate	Differential (Note 6)		4.5		V/ns
t <sub>S1%</sub>	1% Settling Time	2V <sub>P-P,OUT</sub> (Note 6)		0.8		ns
t <sub>OVDR</sub>	Overdrive Recovery Time	1.9V <sub>P-P,OUT</sub> (Note 6)		4		ns
t <sub>ON</sub>	Turn-On Time	+OUT, -OUT Within 10% of Final Values		82		ns
t <sub>OFF</sub>	Turn-Off Time	I <sub>CC</sub> Falls to 10% of Nominal		190		ns
-3dB BW <sub>VOCM</sub>	V <sub>OCM</sub> Pin Small Signal -3dB BW	0.1V <sub>P-P</sub> at V <sub>OCM</sub> , Measured Single-Ended at Output (Note 6)		15		MHz

**10MHz Input Signal**

HD <sub>2,10M</sub> /HD <sub>3,10M</sub>	Second/Third Order Harmonic Distortion	2V <sub>P-P,OUT</sub> , R <sub>L</sub> = 400Ω	-97/-93	dBc
		2V <sub>P-P,OUT</sub> , No R <sub>L</sub>	-98/-97	dBc
		2V <sub>P-P,OUTFILT</sub> , No R <sub>L</sub>	-100/-98	dBc
IMD <sub>3,10M</sub>	Third-Order Intermodulation (f <sub>1</sub> = 9.5MHz f <sub>2</sub> = 10.5MHz)	2V <sub>P-P,OUT</sub> Composite, R <sub>L</sub> = 400Ω	-95	dBc
		2V <sub>P-P,OUT</sub> Composite, No R <sub>L</sub>	-99	dBc
		2V <sub>P-P,OUTFILT</sub> Composite, No R <sub>L</sub>	-100	dBc
OIP <sub>3,10M</sub>	Third-Order Output Intercept Point (f <sub>1</sub> = 9.5MHz f <sub>2</sub> = 10.5MHz)	2V <sub>P-P,OUT</sub> Composite, No R <sub>L</sub> (Note 7)	53.8	dBm
P <sub>1dB,10M</sub>	1dB Compression Point	R <sub>L</sub> = 375Ω (Notes 5, 7)	18	dBm
NF <sub>10M</sub>	Noise Figure	R <sub>L</sub> = 375Ω (Note 5)	6.2	dB
e <sub>IN,10M</sub>	Input Referred Voltage Noise Density	Includes Resistors (Short Inputs)	2.2	nV/√Hz
e <sub>ON,10M</sub>	Output Referred Voltage Noise Density	Includes Resistors (Short Inputs)	21.7	nV/√Hz

**70MHz Input Signal**

HD <sub>2,70M</sub> /HD <sub>3,70M</sub>	Second/Third Order Harmonic Distortion	2V <sub>P-P,OUT</sub> , R <sub>L</sub> = 400Ω	-86/-85	dBc
		2V <sub>P-P,OUT</sub> , No R <sub>L</sub>	-88/-87	dBc
		2V <sub>P-P,OUTFILT</sub> , No R <sub>L</sub>	-86/-88	dBc
IMD <sub>3,70M</sub>	Third-Order Intermodulation (f <sub>1</sub> = 69.5MHz f <sub>2</sub> = 70.5MHz)	2V <sub>P-P,OUT</sub> Composite, R <sub>L</sub> = 400Ω	-93	dBc
		2V <sub>P-P,OUT</sub> Composite, No R <sub>L</sub>	-94	dBc
		2V <sub>P-P,OUTFILT</sub> Composite, No R <sub>L</sub>	-93	dBc
OIP <sub>3,70M</sub>	Third-Order Output Intercept Point (f <sub>1</sub> = 69.5MHz f <sub>2</sub> = 70.5MHz)	2V <sub>P-P,OUT</sub> Composite, No R <sub>L</sub> (Note 7)	51	dBm
P <sub>1dB,70M</sub>	1dB Compression Point	R <sub>L</sub> = 375Ω (Notes 5, 7)	18	dBm
NF <sub>70M</sub>	Noise Figure	R <sub>L</sub> = 375Ω (Note 5)	6.2	dB
e <sub>IN,70M</sub>	Input Referred Voltage Noise Density	Includes Resistors (Short Inputs)	2.1	nV/√Hz
e <sub>ON,70M</sub>	Output Referred Voltage Noise Density	Includes Resistors (Short Inputs)	21	nV/√Hz

**AC ELECTRICAL CHARACTERISTICS**Specifications are at  $T_A = 25^\circ\text{C}$ .  $V^+ = 3\text{V}$ ,  $V^- = 0\text{V}$ ,  $V_{\text{OCM}} = 1.25\text{V}$ ,ENABLE = 0V, No  $R_L$  unless otherwise noted.

SYMBOL	PARAMETER	CONDITIONS	MIN	TYP	MAX	UNITS
<b>140MHz Input Signal</b>						
HD <sub>2,140M</sub> /HD <sub>3,140M</sub>	Second/Third Order Harmonic Distortion	2V <sub>P-P,OUT</sub> , R <sub>L</sub> = 400Ω		-74/-74		dBc
		2V <sub>P-P,OUT</sub> , No R <sub>L</sub>		-73/-83		dBc
		2V <sub>P-P,OUTFILT</sub> , No R <sub>L</sub>		-77/-76		dBc
IMD <sub>3,140M</sub>	Third-Order Intermodulation (f <sub>1</sub> = 139.5MHz f <sub>2</sub> = 140.5MHz)	2V <sub>P-P,OUT</sub> Composite, R <sub>L</sub> = 400Ω		-93		dBc
		2V <sub>P-P,OUT</sub> Composite, No R <sub>L</sub>		-87		dBc
		2V <sub>P-P,OUTFILT</sub> Composite, No R <sub>L</sub>		-89		dBc
OIP <sub>3,140M</sub>	Third-Order Output Intercept Point (f <sub>1</sub> = 139.5MHz f <sub>2</sub> = 140.5MHz)	2V <sub>P-P,OUT</sub> Composite, No R <sub>L</sub> (Notes 7)		47.7		dBm
P <sub>1dB,140M</sub>	1dB Compression Point	R <sub>L</sub> = 375Ω (Notes 5, 7)		18.4		dBm
NF <sub>140M</sub>	Noise Figure	R <sub>L</sub> = 375Ω (Note 5)		6.5		dB
e <sub>IN,140M</sub>	Input Referred Voltage Noise Density	Includes Resistors (Short Inputs)		2.1		nV/√Hz
e <sub>ON,140M</sub>	Output Referred Voltage Noise Density	Includes Resistors (Short Inputs)		21.5		nV/√Hz
<b>240MHz Input Signal</b>						
HD <sub>2,240M</sub> /HD <sub>3,240M</sub>	Second-Order Harmonic Distortion	2V <sub>P-P,OUT</sub> , R <sub>L</sub> = 400Ω		-66/-58		dBc
		2V <sub>P-P,OUT</sub> , No R <sub>L</sub>		-65/-63		dBc
		2V <sub>P-P,OUTFILT</sub> , No R <sub>L</sub>		-65/-58		dBc
IMD <sub>3,240M</sub>	Third-Order Intermodulation (f <sub>1</sub> = 239.5MHz f <sub>2</sub> = 240.5MHz)	2V <sub>P-P,OUT</sub> Composite, R <sub>L</sub> = 400Ω		-71		dBc
		2V <sub>P-P,OUT</sub> Composite, No R <sub>L</sub>		-74		dBc
		2V <sub>P-P,OUTFILT</sub> Composite, No R <sub>L</sub>		-67		dBc
OIP <sub>3,240M</sub>	Third-Order Output Intercept Point (f <sub>1</sub> = 239.5MHz f <sub>2</sub> = 240.5MHz)	2V <sub>P-P,OUT</sub> Composite, No R <sub>L</sub> (Note 7)		41		dBm
P <sub>1dB,240M</sub>	1dB Compression Point	R <sub>L</sub> = 375Ω (Notes 5, 7)		17.9		dBm
NF <sub>240M</sub>	Noise Figure	R <sub>L</sub> = 375Ω (Note 5)		7.1		dB
e <sub>N,240M</sub>	Input Referred Voltage Noise Density	Includes Resistors (Short Inputs)		1.9		nV/√Hz
e <sub>ON,240M</sub>	Output Referred Voltage Noise Density	Includes Resistors (Short Inputs)		21.7		nV/√Hz

**AC ELECTRICAL CHARACTERISTICS**

Specifications are at  $T_A = 25^\circ\text{C}$ .  $V^+ = 3\text{V}$ ,  $V^- = 0\text{V}$ ,  $V_{\text{OCM}} = 1.25\text{V}$ ,  
**ENABLE = 0V, No  $R_L$  unless otherwise noted.**

SYMBOL	PARAMETER	CONDITIONS	MIN	TYP	MAX	UNITS
<b>300MHz Input Signal</b>						
HD <sub>2,300M</sub> /HD <sub>3,300M</sub>	Second-Order Harmonic Distortion	2V <sub>P-P,OUT</sub> , $R_L = 400\Omega$		-61/-53		dBc
		2V <sub>P-P,OUT</sub> , No $R_L$		-60/-55		dBc
		2V <sub>P-P,OUTFILT</sub> , No $R_L$		-63/-46		dBc
IMD <sub>3,300M</sub>	Third-Order Intermodulation (f <sub>1</sub> = 299.5MHz f <sub>2</sub> = 300.5MHz)	2V <sub>P-P,OUT</sub> Composite, $R_L = 400\Omega$		-64		dBc
		2V <sub>P-P,OUT</sub> Composite, No $R_L$		-65		dBc
		2V <sub>P-P,OUTFILT</sub> Composite, No $R_L$		-58		dBc
OIP <sub>3,300M</sub>	Third-Order Output Intercept Point (f <sub>1</sub> = 299.5MHz f <sub>2</sub> = 300.5MHz)	2V <sub>P-P,OUT</sub> Composite, No $R_L$ (Note 7)		36.6		dBm
P <sub>1dB,300M</sub>	1dB Compression Point	$R_L = 375\Omega$ (Notes 5, 7)		17.5		dBm
NF <sub>300M</sub>	Noise Figure	$R_L = 375\Omega$ (Note 5)		7.5		dB
e <sub>N,300M</sub>	Input Referred Voltage Noise Density	Includes Resistors (Short Inputs)		1.8		nV/ $\sqrt{\text{Hz}}$
e <sub>ON,300M</sub>	Output Referred Voltage Noise Density	Includes Resistors (Short Inputs)		22		nV/ $\sqrt{\text{Hz}}$
IMD <sub>3,280M/320M</sub>	Third-Order Intermodulation (f <sub>1</sub> = 280MHz f <sub>2</sub> = 320MHz) Measure at 360MHz	2V <sub>P-P,OUT</sub> Composite, $R_L = 375\Omega$	-64	-70		dBc

**Note 1:** Stresses beyond those listed under Absolute Maximum Ratings may cause permanent damage to the device. Exposure to any Absolute Maximum Rating condition for extended periods may affect device reliability and lifetime.

**Note 2:** Input pins (+IN, -IN) are protected by steering diodes to either supply. If the inputs go beyond either supply rail, the input current should be limited to less than 10mA.

**Note 3:** The LTC6400C and LTC6400I are guaranteed functional over the operating temperature range of  $-40^\circ\text{C}$  to  $85^\circ\text{C}$ .

**Note 4:** The LTC6400C is guaranteed to meet specified performance from  $0^\circ\text{C}$  to  $70^\circ\text{C}$ . It is designed, characterized and expected to meet specified

performance from  $-40^\circ\text{C}$  to  $85^\circ\text{C}$  but is not tested or QA sampled at these temperatures. The LTC6400I is guaranteed to meet specified performance from  $-40^\circ\text{C}$  to  $85^\circ\text{C}$ .

**Note 5:** Input and output baluns used. See Test Circuit A.

**Note 6:** Measured using Test Circuit B.

**Note 7:** Since the LTC6400-20 is a feedback amplifier with low output impedance, a resistive load is not required when driving an AD converter. Therefore, typical output power is very small. In order to compare the LTC6400-20 with amplifiers that require  $50\Omega$  output load, the LTC6400-20 output voltage swing driving a given  $R_L$  is converted to OIP<sub>3</sub> and P<sub>1dB</sub> as if it were driving a  $50\Omega$  load. Using this modified convention, 2V<sub>P-P</sub> is by definition equal to 10dBm, regardless of actual  $R_L$ .

# TYPICAL PERFORMANCE CHARACTERISTICS

**Frequency Response**

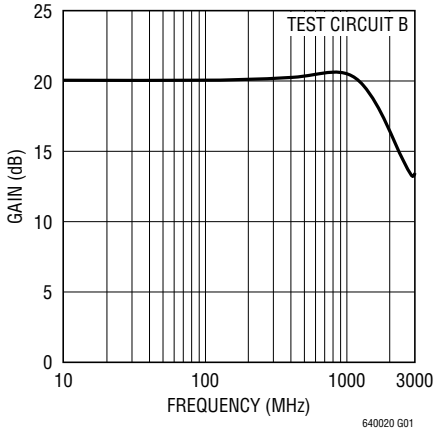

**Gain 0.1dB Flatness**

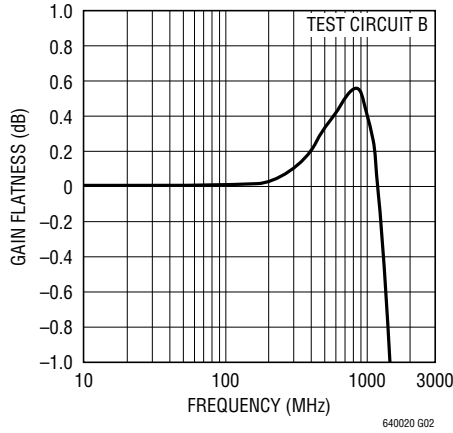

**S21 Phase and Group Delay vs Frequency**

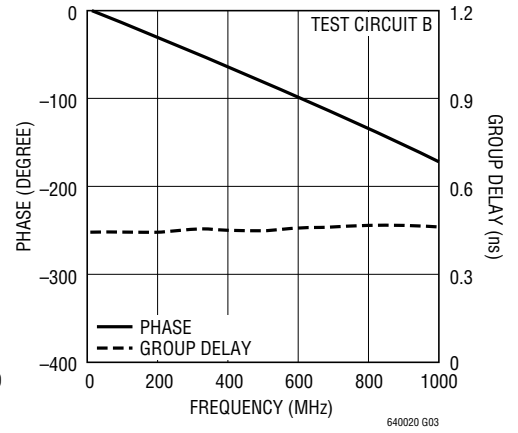

**Input and Output Reflection and Reverse Isolation vs Frequency**

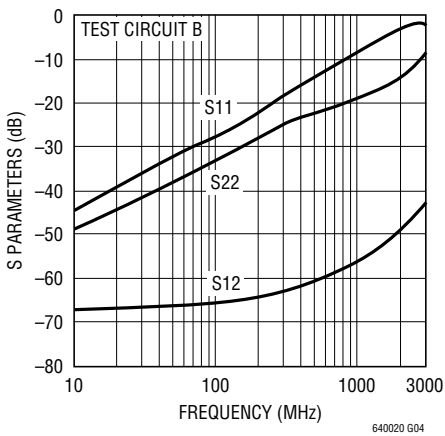

**Input and Output Impedance vs Frequency**

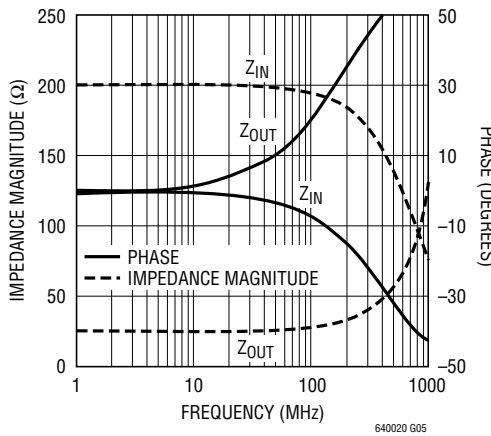

**PSRR and CMRR vs Frequency**

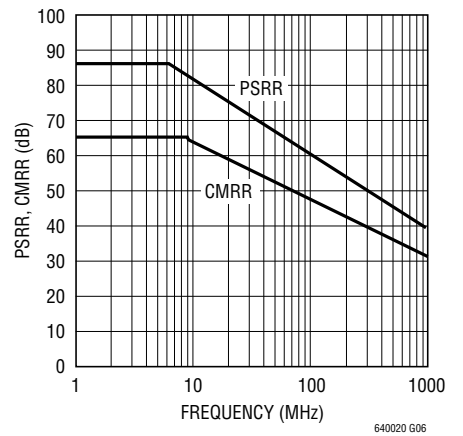

**Noise Figure and Input Referred Noise Voltage vs Frequency**

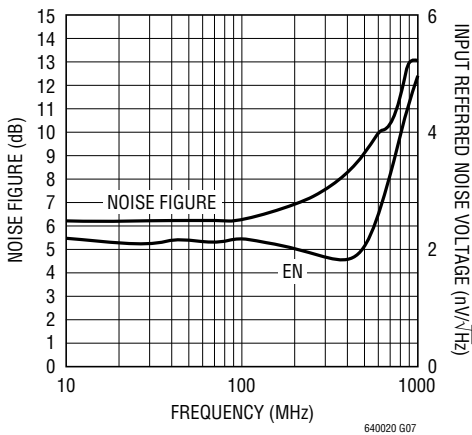

**Small Signal Transient Response**

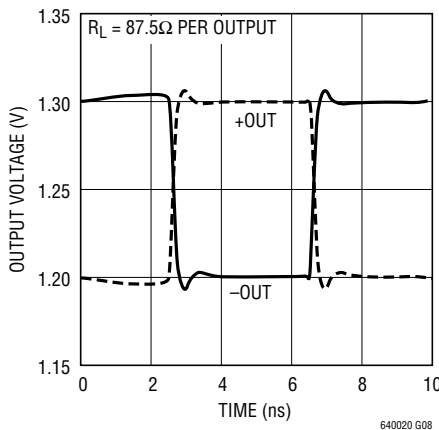

**Large Signal Transient Response**

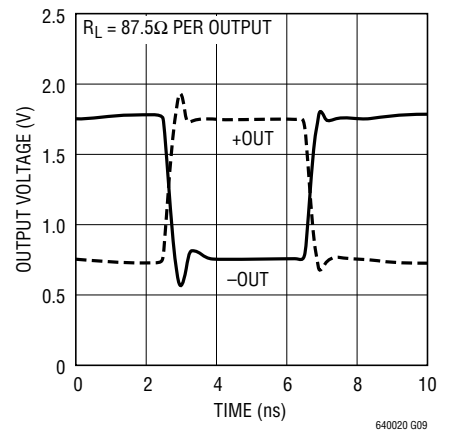

## TYPICAL PERFORMANCE CHARACTERISTICS

### Overdrive Recovery Time

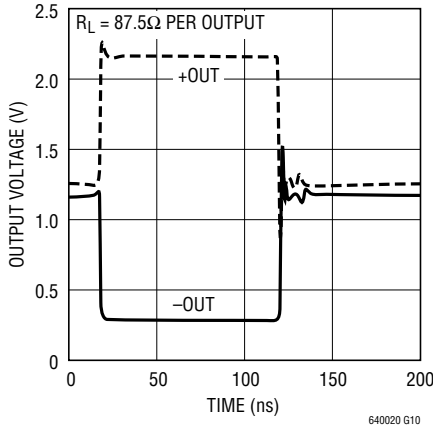

### 1% Settling Time for 2V Output Step

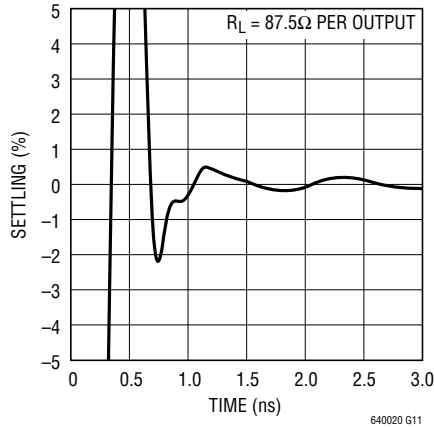

### Harmonic Distortion (Unfiltered) vs Frequency

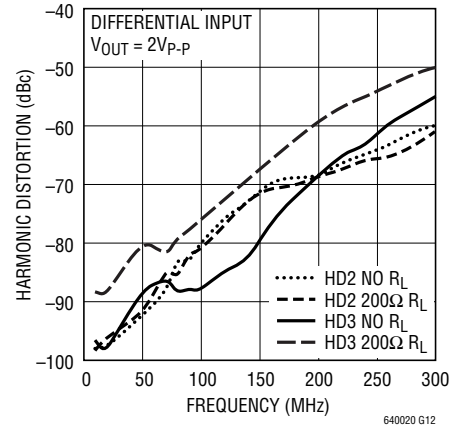

### Harmonic Distortion (Filtered) vs Frequency

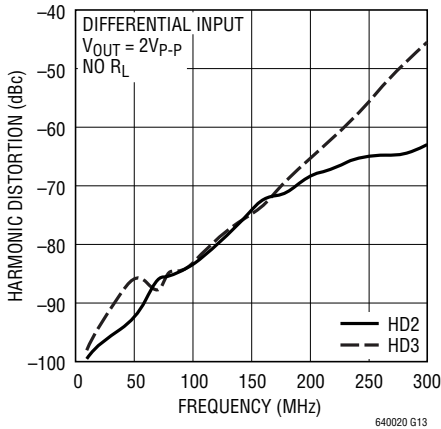

### Third Order Intermodulation Distortion vs Frequency

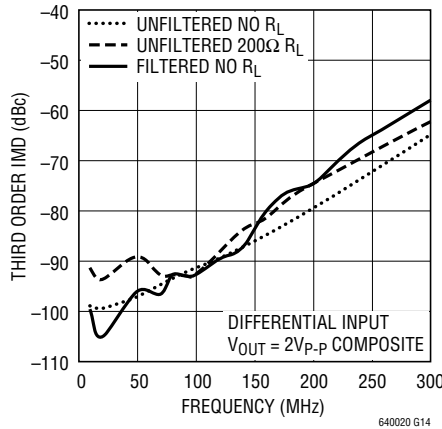

### Harmonic Distortion (Unfiltered) vs Frequency

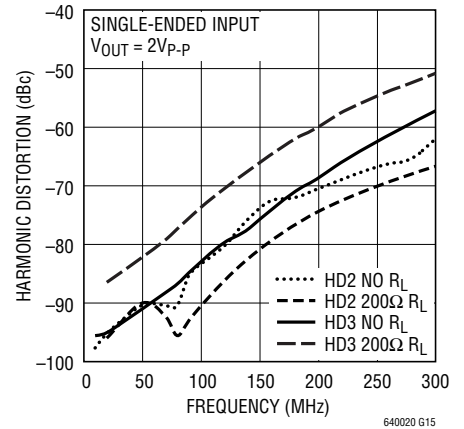

### Harmonic Distortion (Filtered) vs Frequency

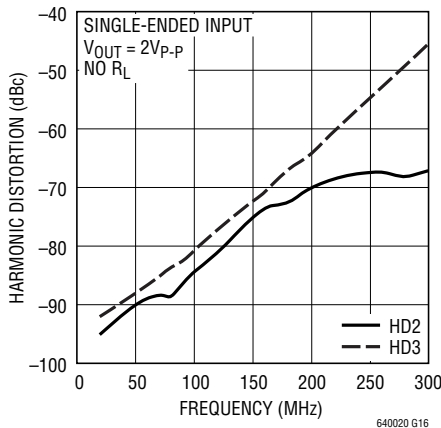

### Third Order Intermodulation Distortion vs Frequency

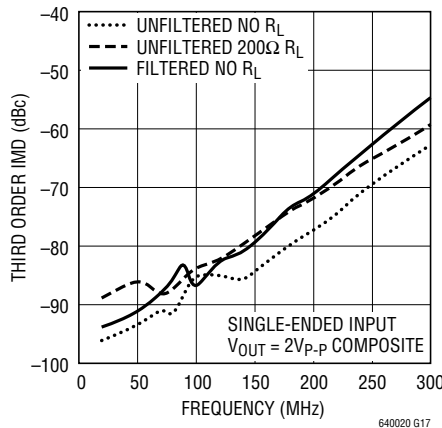

### Harmonic Distortion vs Output Common Mode Voltage (Unfiltered Outputs)

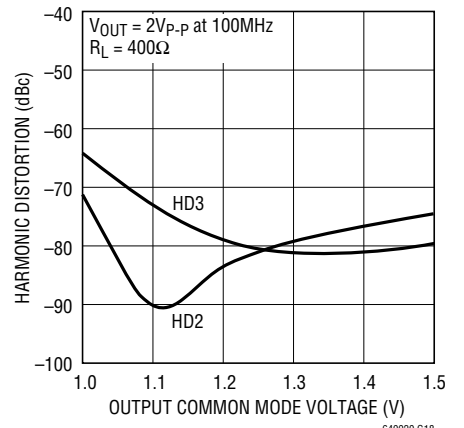

# TYPICAL PERFORMANCE CHARACTERISTICS

**Output 1dB Compression Point vs Frequency**

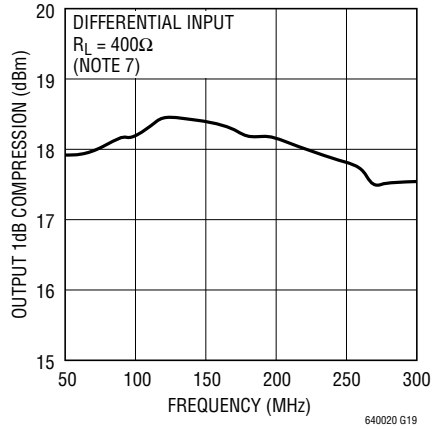

**Output Third Order Intercept vs Frequency**

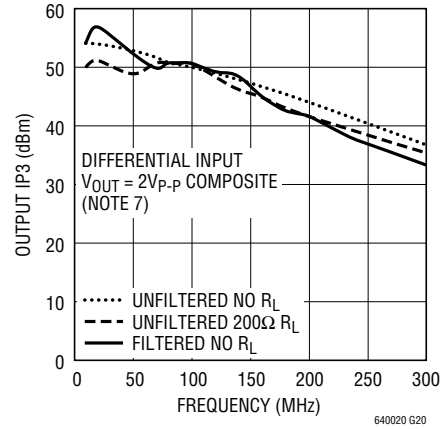

**Turn-On Time**

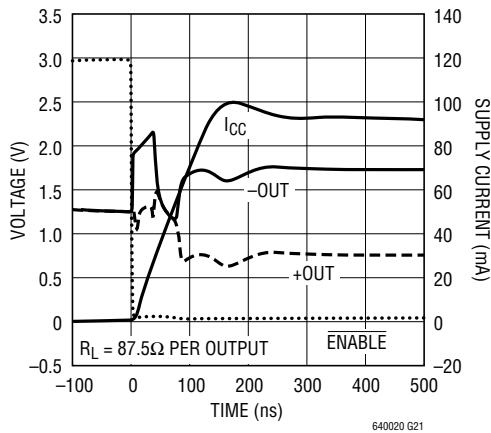

**Turn-Off Time**

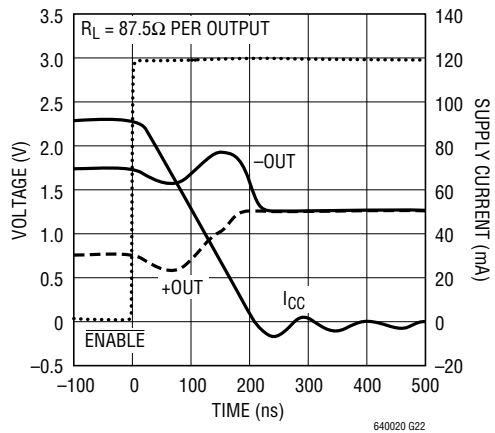

## PIN FUNCTIONS

**V<sup>+</sup> (Pins 1, 3, 10):** Positive Power Supply (Normally tied to 3V or 3.3V). All three pins must be tied to the same voltage. Bypass each pin with 1000pF and 0.1μF capacitors as close to the pins as possible.

**V<sub>OCM</sub> (Pin 2):** This pin sets the output common mode voltage. A 0.1μF external bypass capacitor is recommended.

**V<sup>-</sup> (Pins 4, 9, 12, 17):** Negative Power Supply (GND). All four pins must be connected to same voltage/ground.

**-OUT, +OUT (Pins 5, 8):** Unfiltered Outputs. These pins have series resistors, R<sub>OUT</sub> 12.5Ω.

**-OUTF, +OUTF (Pins 6, 7):** Filtered Outputs. These pins have 50Ω series resistors and a 2.7pF shunt capacitor.

**ENABLE (Pin 11):** This pin is a logic input referenced to V<sub>EE</sub>. If low, the part is enabled. If high, the part is disabled and draws approximately 1mA supply current.

**+IN (Pins 13, 14):** Positive Input. Pins 13 and 14 are internally shorted together.

**-IN (Pins 15, 16):** Negative Input. Pins 15 and 16 are internally shorted together.

**Exposed Pad (Pin 17):** V<sup>-</sup>. The Exposed Pad must be connected to same voltage/ground as pins 4, 9, 12.

## BLOCK DIAGRAM

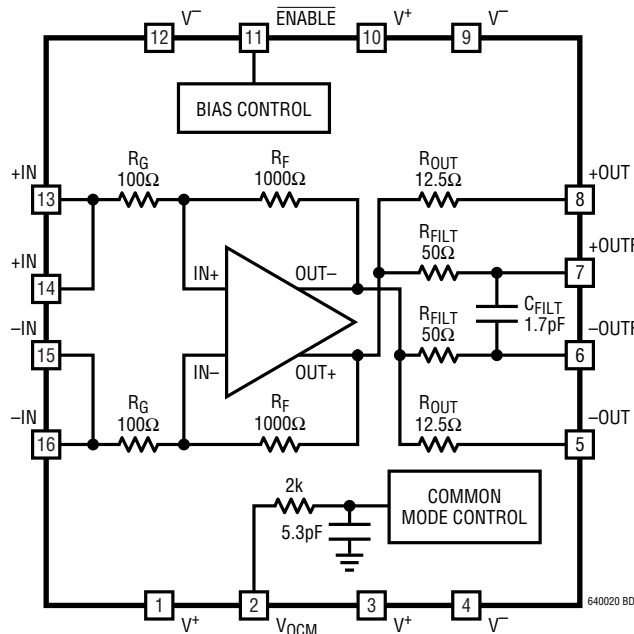

## APPLICATIONS INFORMATION

### Circuit Operation

The LTC6400 is a low noise and low distortion fully differential op amp/ADC driver with:

- Operation from DC to 1.8GHz (–3dB bandwidth)
- Fixed gain of 10V/V (20dB)
- Differential input impedance 200Ω
- Differential output impedance 25Ω
- On-Chip 590MHz output filter

The LTC6400 is composed of a fully differential amplifier with on chip feedback and output common mode voltage control circuitry. Differential gain and input impedance are set by 100Ω/1000Ω resistors in the feedback network. Small output resistors of 12.5Ω improve the circuit stability over various load conditions. They also provide a possible external filtering option, which is often desirable when the load is an ADC.

Filter resistors of 50Ω are available for additional filtering. Lowpass/bandpass filters are easily implemented with just a couple of external components. Moreover, they offer single-ended 50Ω matching in wideband applications and no external resistor is needed.

The LTC6400-20 is very flexible in terms of I/O coupling. It can be AC- or DC-coupled at the inputs, the outputs or both. Due to the internal connection between input and output, users are advised to keep input common mode voltage between 1V and 1.6V for proper operation. If the inputs are AC-coupled, the input common mode voltage is automatically biased close to  $V_{OCM}$  and thus no external circuitry is needed for bias. The LTC6400-20 provides an output common mode voltage set by  $V_{OCM}$ , which allows driving an ADC directly without external components such as a transformer or AC coupling capacitors. The input signal can be either single-ended or differential with only minor differences in distortion performance.

### Input Impedance and Matching

The differential input impedance of the LTC6400-20 is 200Ω. If a 200Ω source impedance is unavailable, then the differential inputs may need to be terminated to a lower

value impedance, e.g. 50Ω, in order to provide an impedance match for the source. Several choices are available. One approach is to use a differential shunt resistor (Figure 1). Another approach is to employ a wide band transformer (Figure 2). Both methods provide a wide band impedance match. The termination resistor or the transformer must be placed close to the input pins in order to minimize the reflection due to input mismatch. Alternatively, one could apply a narrowband impedance match at the inputs of the LTC6400-20 for frequency selection and/or noise reduction.

Referring to Figure 3, LTC6400-20 can be easily configured for single-ended input and differential output without a balun. The signal is fed to one of the inputs through a matching network while the other input is connected to the same matching network and a source resistor. Because the return ratios of the two feedback paths are equal, the two outputs have the same gain and thus symmetrical

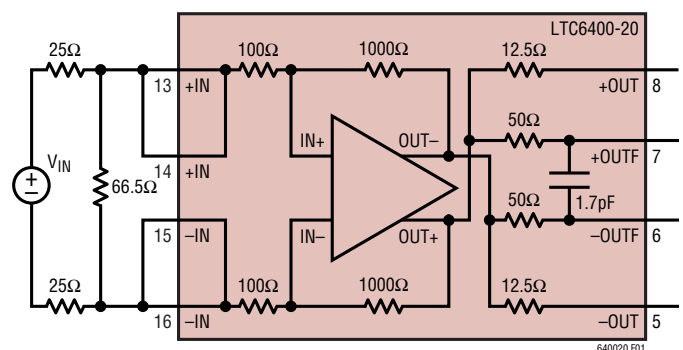

Figure 1. Input Termination for Differential 50Ω Input Impedance Using Shunt Resistor

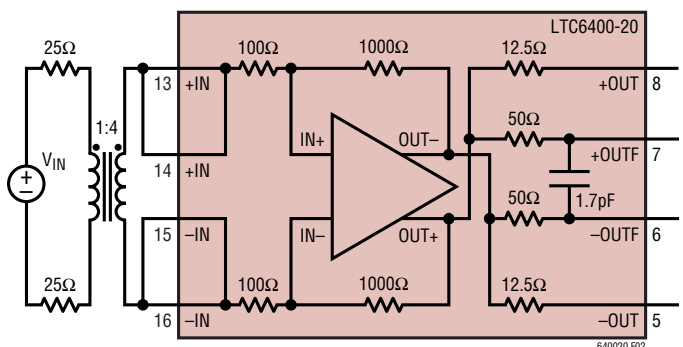

Figure 2. Input Termination for Differential 50Ω Input Impedance Using a 1:4 Balun

APPLICATIONS INFORMATION

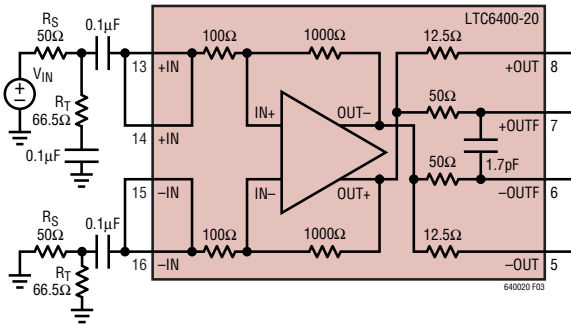

Figure 3. Input Termination for Single-Ended 50Ω Input Impedance

swing. In general, the single-ended input impedance and termination resistor  $R_T$  are determined by the combination of  $R_S$ ,  $R_G$  and  $R_F$ . For example, when  $R_S$  is 50Ω, it is found that the single-ended input impedance is 202Ω and  $R_T$  is 66.5Ω in order to match to a 50Ω source impedance.

The LTC6400-20 is unconditionally stable. However, the overall differential gain is affected by both source impedance and load impedance as shown in Figure 4:

$$A_V = \left| \frac{V_{OUT}}{V_{IN}} \right| = \frac{2000}{R_S + 200} \cdot \frac{R_L}{25 + R_L}$$

The noise performance of the LTC6400-20 also depends upon the source impedance and termination. For example, an input 1:4 balun transformer in Figure 2 improves SNR by adding 6dB of voltage gain at the inputs. A trade-off between gain and noise is obvious when constant noise figure circle and constant gain circle are plotted within the same input Smith Chart, based on which users can choose the optimal source impedance for a given gain and noise requirement.

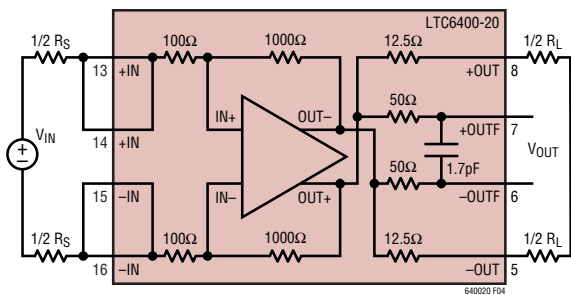

Figure 4. Calculate Differential Gain

Output Match and Filter

The LTC6400-20 can drive an ADC directly without external output impedance matching. Alternatively, the differential output impedance of 25Ω can be matched to higher value impedance, e.g. 50Ω, by series resistors or an LC network.

The internal low pass filter outputs at +OUTF/-OUTF have a -3dB bandwidth of 590MHz. External capacitors can reduce the low pass filter bandwidth as shown in Figure 5. A bandpass filter is easily implemented with only a few components as shown in Figure 6. Three 39pF capacitors and a 16nH inductor create a bandpass filter with 165MHz center frequency, -3dB frequencies at 138MHz and 200MHz.

Output Common Mode Adjustment

The output common mode voltage is set by the  $V_{OCM}$  pin, which is a high impedance input. The output common mode voltage is capable of tracking  $V_{OCM}$  in a range from 1V to

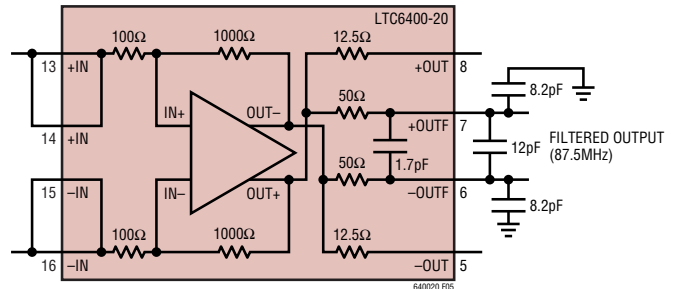

Figure 5. LTC6400-20 Internal Filter Topology Modified for Low Filter Bandwidth (Three External Capacitors)

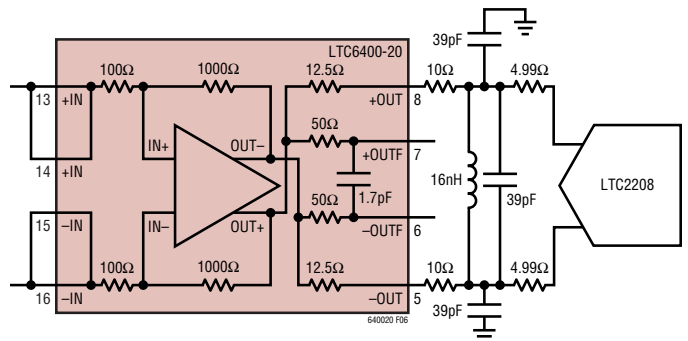

Figure 6. LTC6400-20 Internal Filter Topology Modified for Bandpass Filtering (Three External Capacitors, One External Inductor)

## APPLICATIONS INFORMATION

1.6V. The bandwidth of  $V_{OCM}$  control is typically 15MHz, which is dominated by a low pass filter connected to the  $V_{OCM}$  pin and is aimed to reduce common mode noise generation at the outputs. The internal common mode feedback loop has a  $-3\text{dB}$  bandwidth around 300MHz, allowing fast common mode rejection at the outputs of the LTC6400-20. The  $V_{OCM}$  pin should be tied to a DC bias voltage with a  $0.1\mu\text{F}$  bypass capacitor. When interfacing with A/D converters such as the LT22xx families, the  $V_{OCM}$  pin can be connected to the  $V_{CM}$  pin of the ADC.

### Driving A/D Converters

The LTC6400-20 has been specifically designed to interface directly with high speed A/D converters. In Figure 7, an example schematic shows the LTC6400-20 with a single-ended input driving the LTC2208, which is a 16-bit, 130MSPS ADC. Two external  $10\Omega$  resistors help eliminate potential resonance associated with stray capacitance of PCB traces and bond wires of either the ADC input or the driver output.  $V_{OCM}$  of the LTC6400-20 is connected to  $V_{CM}$  of the LTC2208  $V_{CM}$  pin at 1.25V. Alternatively, a single-ended input signal can be converted to differential signal via a balun and fed to the input of the LTC6400-20. The balun also converts input impedance to match  $50\Omega$  source impedance.

Figure 8 summarizes the spurious free dynamic range (SFDR) for IMD3 of the whole system in Figure 7.

### Test Circuits

Due to the fully-differential design of the LTC6400 and its usefulness in applications with differing characteristic

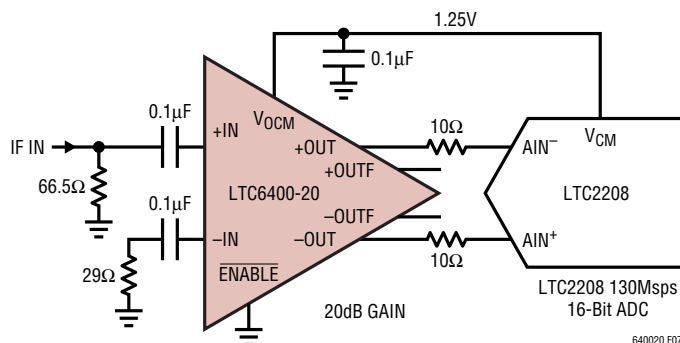

Figure 7. Single-Ended Input to LTC6400-20 and LTC2208

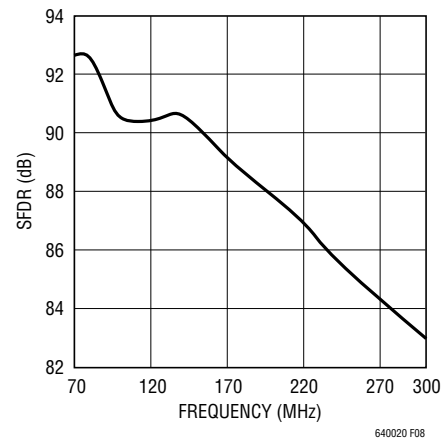
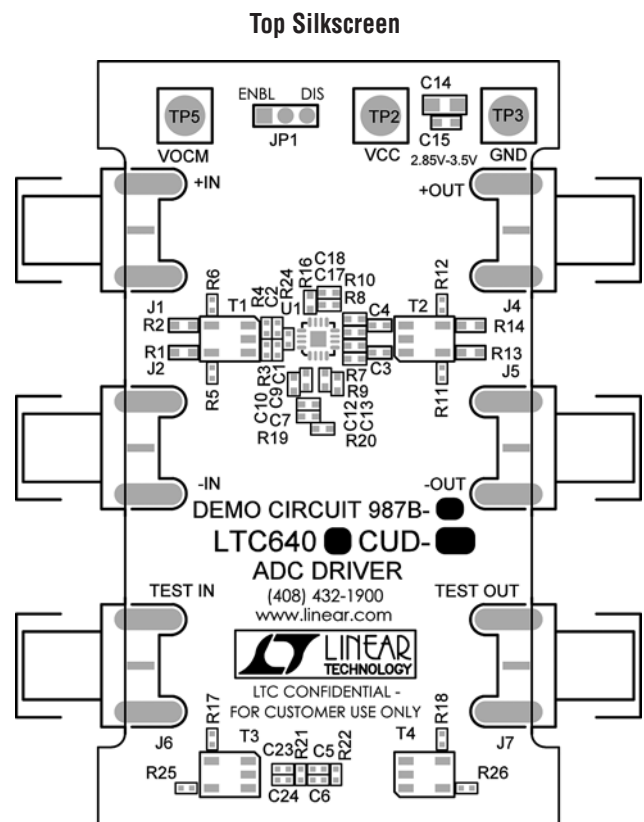

Figure 8. SFDR for the Combination of LTC6400-20 and LTC2208

specifications, two test circuits are used to generate the information in this datasheet. Test Circuit A is DC987B, a two-port demonstration circuit for the LTC6400 family. The schematic and silkscreen are shown below. This circuit includes input and output transformers (baluns) for single-ended-to-differential conversion and impedance transformation, allowing direct hook-up to a 2-port



## APPLICATIONS INFORMATION

network analyzer. There are also series resistors at the output to present the LTC6400 with a 375Ω differential load, optimizing distortion performance. Due to the input and output transformers, the -3dB bandwidth is reduced from 1.8GHz to approximately 1.3GHz.

Test Circuit B uses a 4-port network analyzer to measure S-parameters and gain/phase response. This removes the effects of the wideband baluns and associated circuitry, for true picture of the >1GHz S-parameters and AC characteristics.

## TYPICAL APPLICATIONS

Demo Circuit 987B Schematic (Test Circuit A)

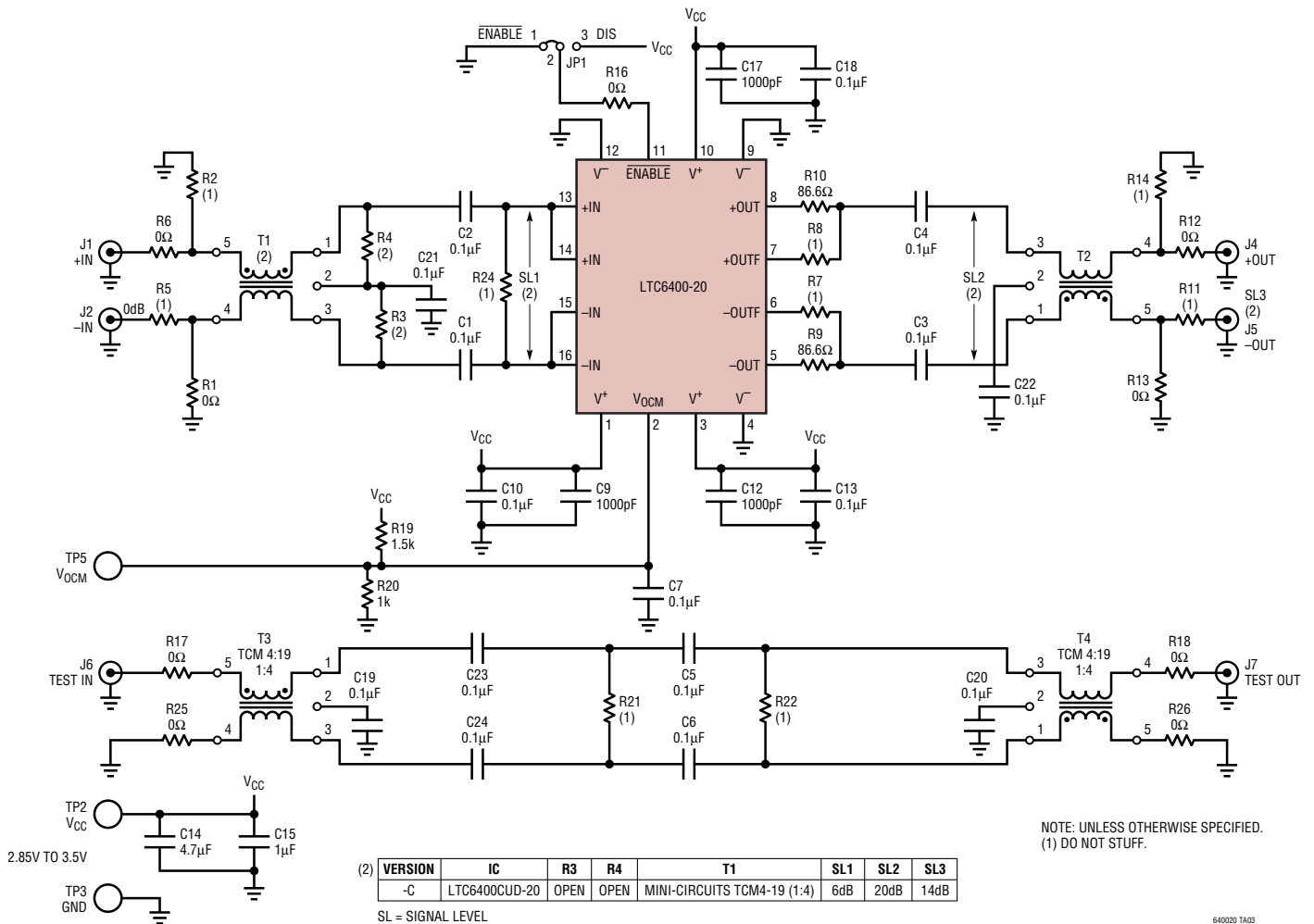

640020 TAO3

# TYPICAL APPLICATIONS

Test Circuit B, 4-Port Analysis

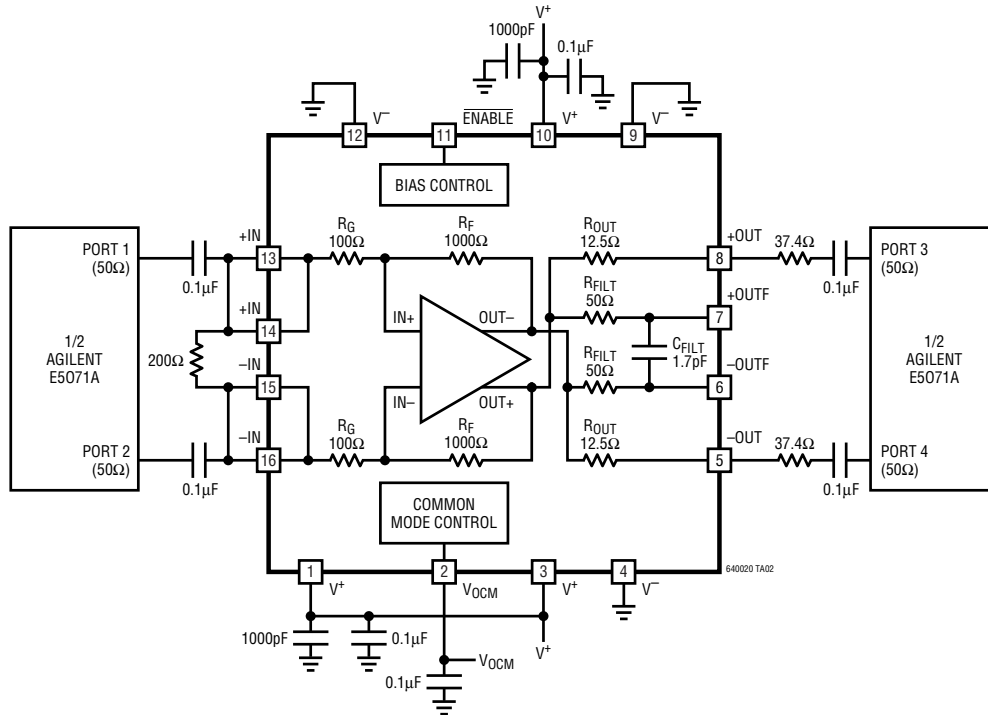

# PACKAGE DESCRIPTION

**UD Package**  
**16-Lead Plastic QFN (3mm × 3mm)**  
 (Reference LTC DWG # 05-08-1691)

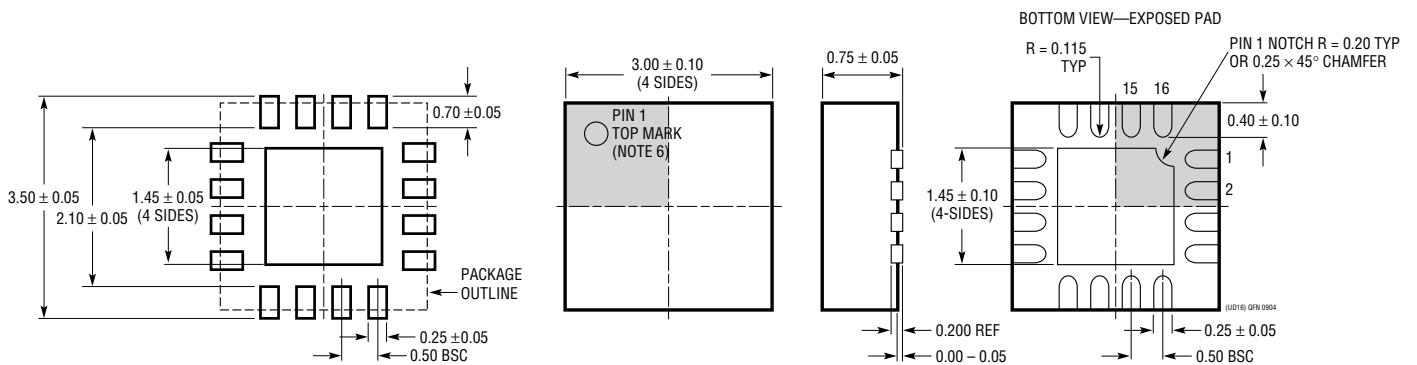

RECOMMENDED SOLDER PAD PITCH AND DIMENSIONS



- NOTE:
1. DRAWING CONFORMS TO JEDEC PACKAGE OUTLINE MO-220 VARIATION (WEED-2)
  2. DRAWING NOT TO SCALE
  3. ALL DIMENSIONS ARE IN MILLIMETERS
  4. DIMENSIONS OF EXPOSED PAD ON BOTTOM OF PACKAGE DO NOT INCLUDE MOLD FLASH. MOLD FLASH, IF PRESENT, SHALL NOT EXCEED 0.15mm ON ANY SIDE
  5. EXPOSED PAD SHALL BE SOLDER PLATED
  6. SHADED AREA IS ONLY A REFERENCE FOR PIN 1 LOCATION ON THE TOP AND BOTTOM OF PACKAGE

## RELATED PARTS





PART NUMBER	DESCRIPTION	COMMENTS
<b>High-Speed Differential Amplifiers/Differential Op Amps</b>		
LT <sup>®</sup> 1993-2	800MHz Differential Amplifier/ADC Driver	$A_V = 2V/V$ , OIP3 = 38dBm at 70MHz
LT1993-4	900MHz Differential Amplifier/ADC Driver	$A_V = 4V/V$ , OIP3 = 40dBm at 70MHz
LT1993-10	700MHz Differential Amplifier/ADC Driver	$A_V = 2V/V$ , OIP3 = 40dBm at 70MHz
LT1994	Low Noise, Low Distortion Differential Op Amp	16-Bit SNR and SFDR at 1MHz, Rail-to-Rail Outputs
LT5514	Ultralow Distortion IF Amplifier/ADC Driver with Digitally Controlled Gain	OIP3 = 47dBm at 100MHz, Gain Control Range 10.5dB to 33dB
LT5524	Low Distortion IF Amplifier/ADC Driver with Digitally Controlled Gain	OIP3 = 40dBm at 100MHz, Gain Control Range 4.5dB to 37dB
LTC6401-20	1.3GHz Low Noise, Low Distortion, Differential ADC Driver	$A_V = 20dB$ , 50mA Supply Current, $IMD_3 = -74dBc$ at 140MHz
LT6402-6	300MHz Differential Amplifier/ADC Driver	$A_V = 6dB$ , Distortion < -80dBc at 25MHz
LT6402-12	300MHz Differential Amplifier/ADC Driver	$A_V = 12dB$ , Distortion < -80dBc at 25MHz
LT6402-20	300MHz Differential Amplifier/ADC Driver	$A_V = 20dB$ , Distortion < -80dBc at 25MHz
LTC6406	3GHz Rail-to-Rail Input Differential Op Amp	1.6nV/ $\sqrt{Hz}$ Noise, -72dBc Distortion at 50MHz, 18mA
LT6411	Low Power Differential ADC Driver/Dual Selectable Gain Amplifier	16mA Supply Current, $IMD_3 = -83dBc$ at 70MHz, $A_V = 1, -1$ or 2
<b>High-Speed Single-Ended Output Op Amps</b>		
LT1812/LT1813/ LT1814	High Slew Rate Low Cost Single/Dual/Quad Op Amps	8nV/ $\sqrt{Hz}$ Noise, 750V/ $\mu s$ , 3mA Supply Current
LT1815/LT1816/ LT1817	Very High Slew Rate Low Cost Single/Dual/Quad Op Amps	6nV/ $\sqrt{Hz}$ Noise, 1500V/ $\mu s$ , 6.5mA Supply Current
LT1818/LT1819	Ultra High Slew Rate Low Cost Single/Dual Op Amps	6nV/ $\sqrt{Hz}$ Noise, 2500V/ $\mu s$ , 9mA Supply Current
LT6200/LT6201	Rail-to-Rail Input and Output Low Noise Single/Dual Op Amps	0.95nV/ $\sqrt{Hz}$ Noise, 165MHz GBW, Distortion = -80dBc at 1MHz
LT6202/LT6203/ LT6204	Rail-to-Rail Input and Output Low Noise Single/Dual/Quad Op Amps	1.9nV/ $\sqrt{Hz}$ Noise, 3mA Supply Current, 100MHz GBW
LT6230/LT6231/ LT6232	Rail-to-Rail Output Low Noise Single/Dual/Quad Op Amps	1.1nV/ $\sqrt{Hz}$ Noise, 3.5mA Supply Current, 215MHz GBW
LT6233/LT6234/ LT6235	Rail-to-Rail Output Low Noise Single/Dual/Quad Op Amps	1.9nV/ $\sqrt{Hz}$ Noise, 1.2mA Supply Current, 60MHz GBW
<b>Integrated Filters</b>		
LTC1562-2	Very Low Noise, 8th Order Filter Building Block	Lowpass and Bandpass Filters up to 300kHz
LT1568	Very Low Noise, 4th Order Filter Building Block	Lowpass and Bandpass Filters up to 10MHz
LTC1569-7	Linear Phase, Tunable 10th Order Lowpass Filter	Single-Resistor Programmable Cut-Off to 300kHz
LT6600-2.5	Very Low Noise Differential 2.5MHz Lowpass Filter	SNR = 86dB at 3V Supply, 4th Order Filter
LT6600-5	Very Low Noise Differential 5MHz Lowpass Filter	SNR = 82dB at 3V Supply, 4th Order Filter
LT6600-10	Very Low Noise Differential 10MHz Lowpass Filter	SNR = 82dB at 3V Supply, 4th Order Filter
LT6600-15	Very Low Noise Differential 15MHz Lowpass Filter	SNR = 76dB at 3V Supply, 4th Order Filter
LT6600-20	Very Low Noise Differential 20MHz Lowpass Filter	SNR = 76dB at 3V Supply, 4th Order Filter

## Looking for pricing, stock, or lifecycle information?

Click below to explore more details on WIN SOURCE:

-  [View LTC6400CUD-20#PBF on WIN SOURCE](#)
-  [Linear Technology Information](#)

## Optimize Your Supply Chain with WIN SOURCE Solutions

-  Global Sourcing Solution
-  Obsolete Management
-  Cost Control Management
-  Shortage Management
-  Alternative Solution
-  Excess Inventory Management