



**THE DATASHEET OF
LTC4300A-3CDD#PBF**



Level-Shifting Hot Swappable 2-Wire Bus Buffer with Enable

FEATURES

- Bidirectional Buffer* for SDA and SCL Lines Increases Fanout
- Prevents SDA and SCL Corruption During Live Board Insertion and Removal From Backplane
- Logic Threshold ENABLE Input
- Isolates Input SDA and SCL Lines From Output
- Compatible with I²C, I²C Fast Mode and SMBus Standards (Up to 400kHz Operation)
- 1V Precharge on all SDA and SCL Lines
- Supports Clock Stretching, Arbitration and Synchronization
- 5V to 3.3V Level Translation
- High Impedance SDA, SCL Pins for $V_{CC} = 0V$, $V_{CC2} = 0V$
- Small 8-Lead DFN and MSOP Packages

APPLICATIONS

- Hot Board Insertion
- Servers
- Capacitance Buffer/Bus Extender
- Desktop Computer

DESCRIPTION

The LTC[®]4300A-3 hot swappable 2-wire bus buffer allows I/O card insertion into a live backplane without corruption of the data and clock busses. When the connection is made, the LTC4300A-3 provides bidirectional buffering, keeping the backplane and card capacitances isolated. Rise time accelerator circuitry allows the use of weaker DC pull-up currents while still meeting rise time requirements. During insertion, the SDA and SCL lines are precharged to 1V to minimize bus disturbances.

The LTC4300A-3 provides level translation between 3.3V and 5V supplies. The backplane and card can both be powered with supplies ranging from 2.7V to 5.5V. The LTC4300A-3 also incorporates a CMOS threshold ENABLE pin which forces the part into a low current mode and isolates the card from the backplane. When driven to V_{CC} , the ENABLE pin sets normal operation.

The LTC4300A-3 is available in the MSOP and 3mm × 3mm DFN packages.

LT, LT, LTC, LTM, Linear Technology and the Linear logo are registered trademarks and Hot Swap and ThinSOT are trademarks of Linear Technology Corporation. All other trademarks are the property of their respective owners. *Patent pending.

TYPICAL APPLICATION

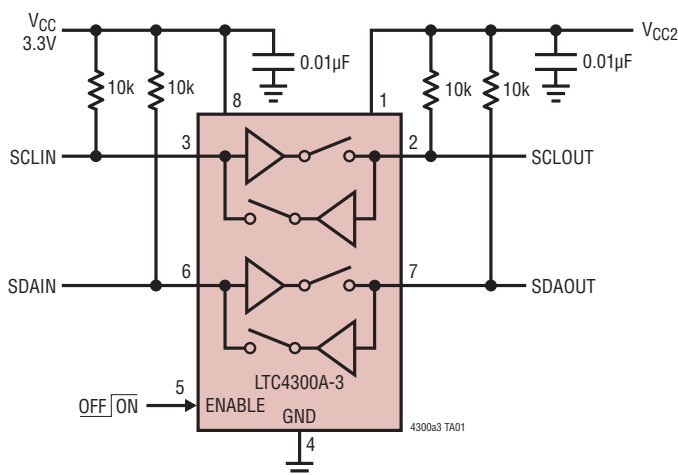

Input-Output Connection

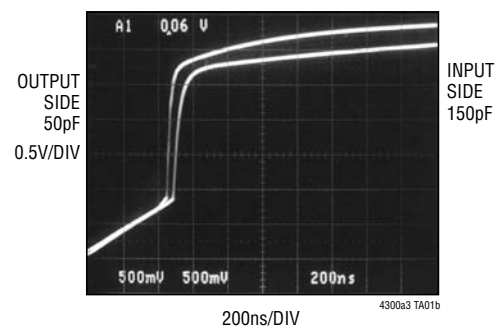

LTC4300A-3

ABSOLUTE MAXIMUM RATINGS (Note 1)

V_{CC} to GND	-0.3V to 7V	Storage Temperature Range	
V_{CC2} to GND.....	-0.3V to 7V	MSOP	-65°C to 150°C
SDAIN, SCLIN, SDAOUT, SCLOUT.....	-0.3V to 7V	DFN.....	-65°C to 125°C
ENABLE.....	-0.3V to 7V	Lead Temperature (Soldering, 10 sec)	
Operating Temperature Range		MSOP Only	300°C
LTC4300A-3C	0°C to 70°C		
LTC4300A-3I.....	-40°C to 85°C		

PIN CONFIGURATION

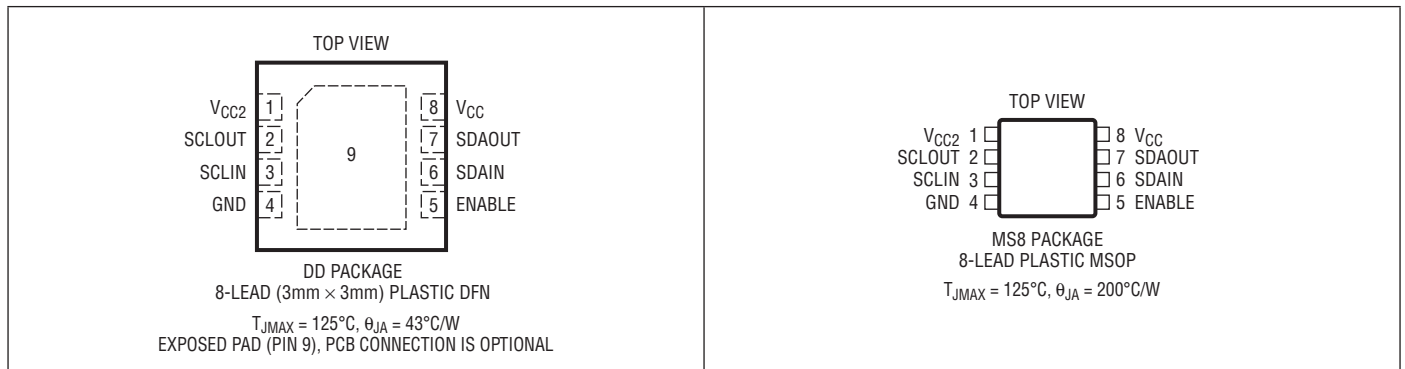

ORDER INFORMATION

LEAD FREE FINISH	TAPE AND REEL	PART MARKING*	PACKAGE DESCRIPTION	TEMPERATURE RANGE
LTC4300A-3CDD#PBF	LTC4300A-3CDD#TRPBF	LBHG	8-Lead (3mm × 3mm) Plastic DFN	0°C to 70°C
LTC4300A-3IDD#PBF	LTC4300A-3IDD#TRPBF	LBHG	8-Lead (3mm × 3mm) Plastic DFN	-40°C to 85°C
LTC4300A-3CMS8#PBF	LTC4300A-3CMS8#TRPBF	LTBHD	8-Lead Plastic MSOP	0°C to 70°C
LTC4300A-3IMS8#PBF	LLTC4300A-3IMS8#TRPBF	LTBHF	8-Lead Plastic MSOP	-40°C to 85°C

Consult LTC Marketing for parts specified with wider operating temperature ranges. *The temperature grade is identified by a label on the shipping container.

For more information on lead free part marking, go to: <http://www.linear.com/leadfree/>

For more information on tape and reel specifications, go to: <http://www.linear.com/tapeandreeel/>

ELECTRICAL CHARACTERISTICS

The ● denotes the specifications which apply over the full operating temperature range, otherwise specifications are at $T_A = 25^\circ\text{C}$. $V_{CC} = 2.7\text{V}$ to 5.5V , $V_{CC2} = 2.7\text{V}$ to 5.5V , unless otherwise noted.

SYMBOL	PARAMETER	CONDITIONS	MIN	TYP	MAX	UNITS	
Power Supply							
V_{CC}	Positive Supply Voltage		●	2.7	5.5	V	
V_{CC2}	Card Side Supply Voltage		●	2.7	5.5	V	
I_{SD}	Supply Current in Shutdown Mode	$V_{ENABLE} = 0\text{V}$		20		μA	
I_{VCC1}	V_{CC} Supply Current	$V_{SDAIN} = V_{SCLIN} = 0\text{V}$, $V_{CC1} = V_{CC2} = 5.5\text{V}$		3	4.1	mA	
I_{VCC2}	V_{CC2} Supply Current	$V_{SDAOUT} = V_{SCLOUT} = 0\text{V}$, $V_{CC1} = V_{CC2} = 5.5\text{V}$		2.1	2.9	mA	
Start-Up Circuitry							
V_{PRE}	Precharge Voltage	SDA, SCL Floating	●	0.8	1.0	1.2	V
t_{IDLE}	Bus Idle Time		●	50	95	150	μs
V_{EN}	ENABLE Threshold Voltage			$0.5 \cdot V_{CC}$	$0.9 \cdot V_{CC}$		V
V_{DIS}	Disable Threshold Voltage	ENABLE Pin		$0.1 \cdot V_{CC}$	$0.5 \cdot V_{CC}$		V
I_{EN}	ENABLE Input Current	ENABLE from 0V to V_{CC}		± 0.1	± 1		μA
t_{PHL}	ENABLE Delay, On-Off			10			ns
t_{PLH}	ENABLE Delay, Off-On			95			μs
Rise Time Accelerators							
$I_{PULLUPAC}$	Transient Boosted Pull-Up Current	Positive Transition on SDA, SCL, $V_{CC} = 2.7\text{V}$, $V_{CC2} = 2.7\text{V}$, Slew Rate = $1.25\text{V}/\mu\text{s}$ (Note 2)		1	2		mA
Input-Output Connection							
V_{OS}	Input-Output Offset Voltage	10k to V_{CC} on SDA, SCL, $V_{CC} = 3.3\text{V}$ (Note 3), $V_{CC2} = 3.3\text{V}$, $V_{IN} = 0.2\text{V}$	●	0	100	175	mV
$f_{SCL, SDA}$	Operating Frequency	Guaranteed by Design, Not Subject to Test		0		400	kHz
C_{IN}	Digital Input Capacitance	Guaranteed by Design, Not Subject to Test				10	pF
V_{OL}	Output Low Voltage, Input = 0V	SDA, SCL Pins, $I_{SINK} = 3\text{mA}$, $V_{CC} = 2.7\text{V}$, $V_{CC2} = 2.7\text{V}$	●	0		0.4	V
I_{LEAK}	Input Leakage Current	SDA, SCL Pins = $V_{CC} = 5.5\text{V}$, $V_{CC2} = 5.5\text{V}$				± 5	μA
Timing Characteristics							
f_{I2C}	I ² C Operating Frequency	(Note 4)		0		400	kHz
t_{BUF}	Bus Free Time Between Stop and Start Condition	(Note 4)		1.3			μs
$t_{HD, STA}$	Hold Time After (Repeated) Start Condition	(Note 4)		0.6			μs
$t_{SU, STA}$	Repeated Start Condition Setup Time	(Note 4)		0.6			μs
$t_{SU, STO}$	Stop Condition Setup Time	(Note 4)		0.6			μs
$t_{HD, DAT}$	Data Hold Time	(Note 4)		300			ns
$t_{SU, DAT}$	Data Setup Time	(Note 4)		100			ns
t_{LOW}	Clock Low Period	(Note 4)		1.3			μs
t_{HIGH}	Clock High Period	(Note 4)		0.6			μs
t_f	Clock, Data Fall Time	(Notes 4, 5)		$20 + 0.1 \cdot C_B$		300	ns
t_r	Clock, Data Rise Time	(Notes 4, 5)		$20 + 0.1 \cdot C_B$		300	ns
$t_{PHL, SKEW}$	High-to-Low Propagation Delay Skew, SCL-SDA	$V_{CC} = 2.7\text{V}$, $V_{CC2} = 5.5\text{V}$; $V_{CC} = 5.5\text{V}$, $V_{CC2} = 2.7\text{V}$ (Note 6)	●		0	± 75	ns

ELECTRICAL CHARACTERISTICS

Note 1: Stresses beyond those listed under Absolute Maximum Ratings may cause permanent damage to the device. Exposure to any Absolute Maximum Rating condition for extended periods may affect device reliability and lifetime.

Note 2: $I_{PULLUPAC}$ varies with temperature and V_{CC} voltage, as shown in the Typical Performance Characteristics section.

Note 3: The connection circuitry always regulates its output to a higher voltage than its input. The magnitude of this offset voltage as a function of the pull-up resistor and V_{CC} voltage is shown in the Typical Performance Characteristics section.

Note 4: Guaranteed by design, not subject to test.

Note 5: C_B = total capacitance of one bus line in pF.

Note 6: These tests measure the difference in high-to-low propagation delay t_{PHL} between the clock and data channels. The delay on each channel is measured from the 50% point of the falling driven input signal to the 50% point of the output driven by the LTC4300A-3. The skew is defined as $(t_{PHL(SCL)} - t_{PHL(SDA)})$. Testing is performed in both directions—from input bus to output bus and vice versa. Tests are performed with approximately 500pF of distributed equivalent capacitance on each SDA and SCL pin.

TYPICAL PERFORMANCE CHARACTERISTICS

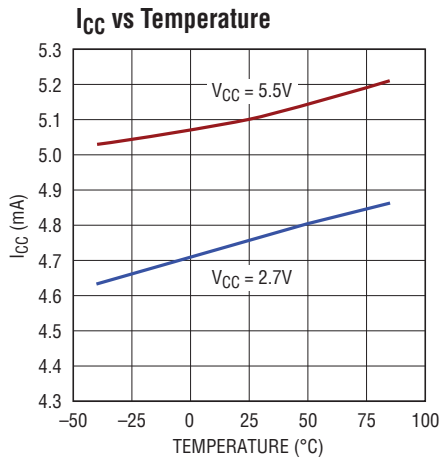

4300a3 G01

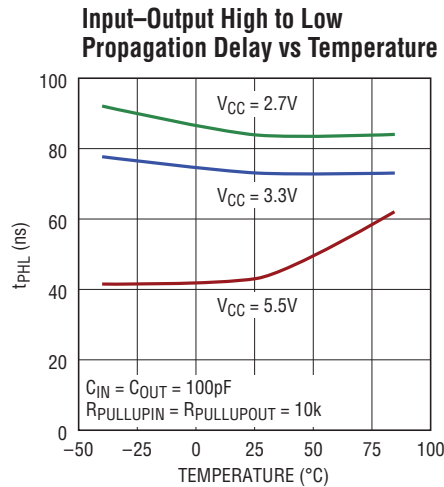

4300a3 G02

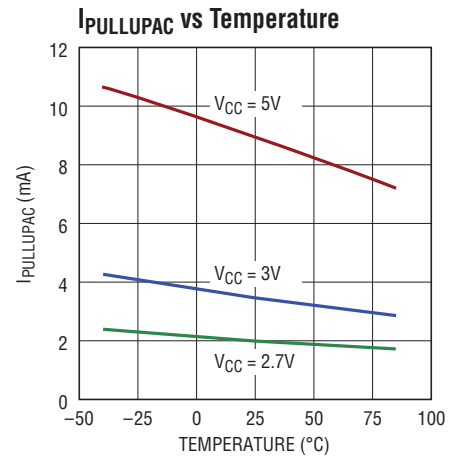

4300a3 G03

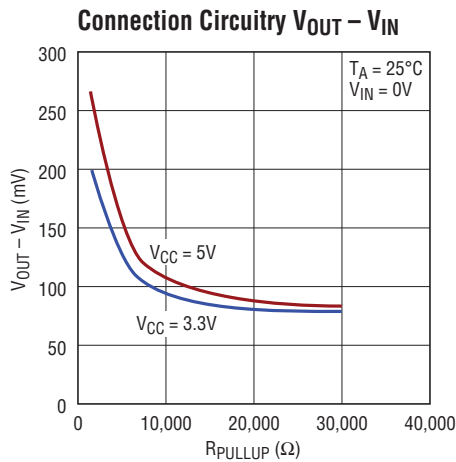

4300a3 G04

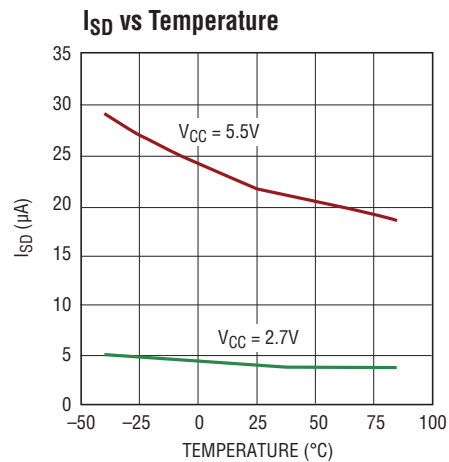

4300a3 G05

PIN FUNCTIONS (DFN/MSOP)

V_{CC2} (Pin 1): Card Supply Voltage. This is the supply voltage for the devices on the card I²C busses. Connect pull-up resistors from SDAOUT and SCLOUT to this pin. Place a bypass capacitor of at least 0.01μF close to this pin for best results.

SCLOUT (Pin 2): Serial Clock Output. Connect this pin to the SCL bus on the card.

SCLIN (Pin 3): Serial Clock Input. Connect this pin to the SCL bus on the backplane.

GND (Pin 4): Device Ground. Connect this pin to a ground plane for best results.

ENABLE (Pin 5): Digital CMOS Threshold Input. Grounding this pin puts the part in a low current mode. It also disables the rise time accelerators, disables the bus discharge circuitry, isolates SDAIN from SDOUT and

isolates SCLIN from SCLOUT. For active operation, drive this pin to V_{CC}. If this feature is unused, tie to V_{CC}. Since ENABLE is V_{CC} referenced, do not connect to V_{CC2} or pull up to V_{CC2}.

SDAIN (Pin 6): Serial Data Input. Connect this pin to the SDA bus on the backplane.

SDAOUT (Pin 7): Serial Data Output. Connect this pin to the SDA bus on the card.

V_{CC} (Pin 8): Main Input Power Supply from Backplane. This is the supply voltage for the devices on the backplane I²C busses. Connect pull-up resistors from SDAIN and SCLIN to this pin. Place a bypass capacitor of at least 0.01μF close to this pin for best results.

Exposed Pad (Pin 9, DFN Package Only): Exposed pad may be left open or connected to device ground.

BLOCK DIAGRAM

2-Wire Bus Buffer and Hot Swap™ Controller

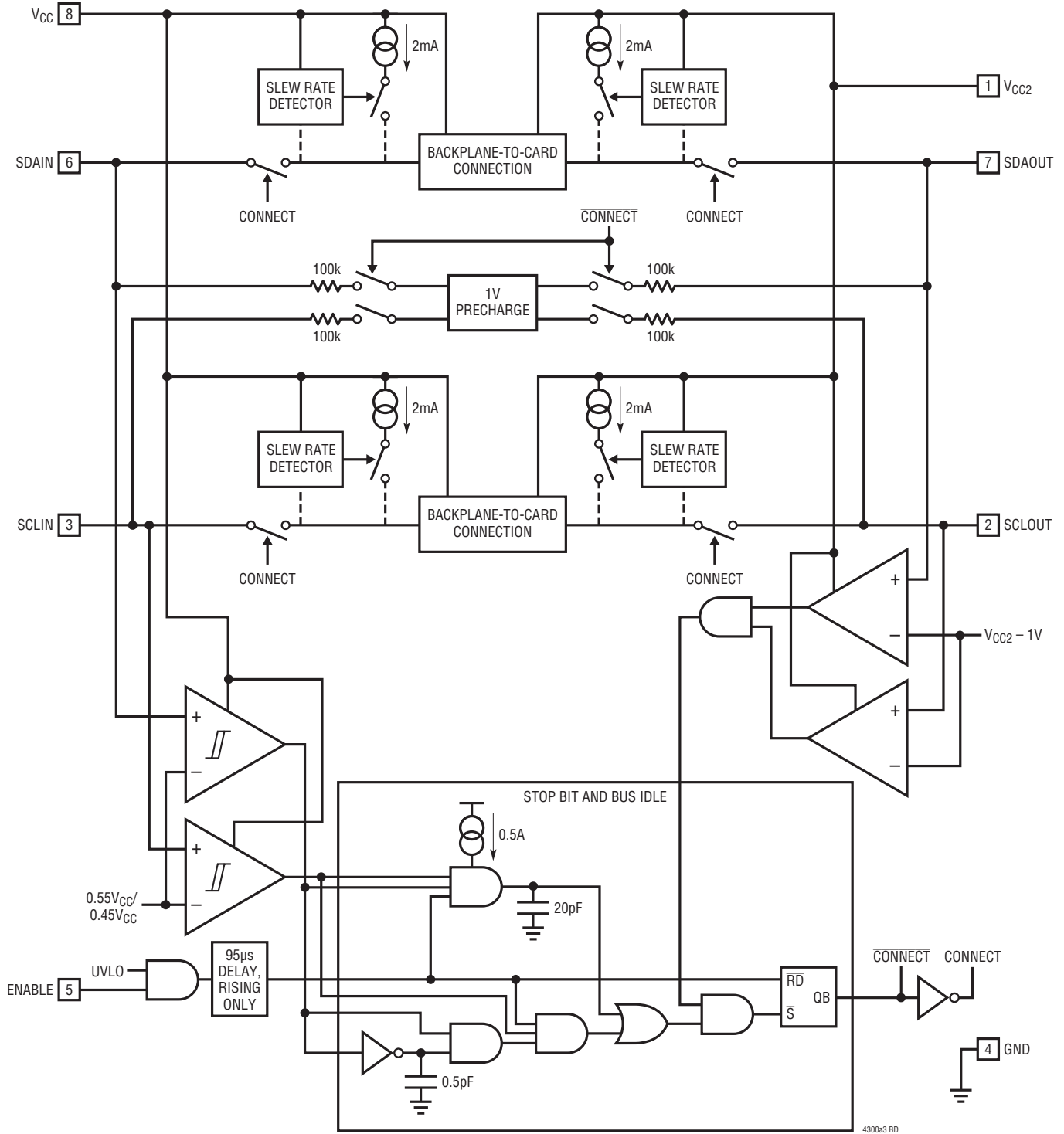

OPERATION

Start-Up

When the LTC4300A-3 first receives power on its V_{CC} pin, either during power-up or during live insertion, it starts in an undervoltage lockout (UVLO) state, ignoring any activity on the SDA and SCL pins until V_{CC} rises above 2.5V. The part also waits for V_{CC2} to rise above 2V. This ensures that the part does not try to function until it has enough voltage to do so.

During this time, the 1V precharge circuitry is also active and forces 1V through 100k nominal resistors to the SDA and SCL pins. Because the I/O card is being plugged into a live backplane, the voltage on the backplane SDA and SCL busses may be anywhere between 0V and V_{CC} . Precharging the SCL and SDA pins to 1V minimizes the worst-case voltage differential these pins will see at the moment of connection, therefore minimizing the amount of disturbance caused by the I/O card.

Once the LTC4300A-3 comes out of UVLO, it assumes that SDAIN and SCLIN have been inserted into a live system and that SDAOUT and SCLOUT are being powered up at the same time as itself. Therefore, it looks for either a stop bit or bus idle condition on the backplane side to indicate the completion of a data transaction. When either one occurs, the part also verifies that both the SDAOUT and SCLOUT voltages are high. When all of these conditions are met, the input-to-output connection circuitry is activated, joining the SDA and SCL busses on the I/O card with those on the backplane, and the rise time accelerators are enabled.

Connection Circuitry

Once the connection circuitry is activated, the functionality of the SDAIN and SDAOUT pins is identical. A low forced on either pin at any time results in both pin voltages being low. For proper operation, logic low input voltages should be no higher than 0.4V with respect to the ground pin voltage of the LTC4300A-3. SDAIN and SDAOUT enter a logic high state only when all devices on both SDAIN and SDAOUT release high. The same is true for SCLIN and SCLOUT. This important feature ensures that clock stretching, clock synchronization, arbitration and the acknowledge protocol always work, regardless of how the devices in the system are tied to the LTC4300A-3.

Another key feature of the connection circuitry is that it provides bidirectional buffering, keeping the backplane and card capacitances isolated. Because of this isolation, the waveforms on the backplane busses look slightly different than the corresponding card bus waveforms, as described here.

Input to Output Offset Voltage

When a logic low voltage, V_{LOW1} , is driven on any of the LTC4300A-3's data or clock pins, the LTC4300A-3 regulates the voltage on the other side of the part (call it V_{LOW2}) to a slightly higher voltage, as directed by the following equation (typical):

$$V_{LOW2} = V_{LOW1} + 75\text{mV} + (V_{CC}/R) \cdot 70 [\Omega]$$

where R is the bus pull-up resistance in ohms. For example, if a device is forcing SDAOUT to 10mV where $V_{CC} = 3.3\text{V}$ and the pull-up resistor R on SDAIN is 10k, then the voltage on SDAIN = $10\text{mV} + 75\text{mV} + (3.3/10000) \cdot 70 = 108\text{mV}$ (typical). See the Typical Performance Characteristics section for curves showing the offset voltage as a function of V_{CC} and R.

Propagation Delays

During a rising edge, the rise time on each side is determined by the combined pull-up current of the LTC4300A-3 boost current and the bus resistor and the equivalent capacitance on the line. If the pull-up currents are the same, a difference in rise time occurs which is directly proportional to the difference in capacitance between the two sides. This effect is displayed in Figure 1 for $V_{CC} = V_{CC2} = 3.3\text{V}$ and a 10k pull-up resistor on each side (50pF on one side and 150pF on the other). Since the output side has less capacitance than the input, it rises faster and the effective propagation delay is negative.

There is a finite propagation delay through the connection circuitry for falling waveforms. Figure 2 shows the falling edge waveforms for the same V_{CC} , pull-up resistors and equivalent capacitance conditions as used in Figure 1. An external NMOS device pulls down the voltage on the side with 150pF capacitance; the LTC4300A-3 pulls down the voltage on the opposite side, with a delay of 55ns. This delay is always positive and is a function of

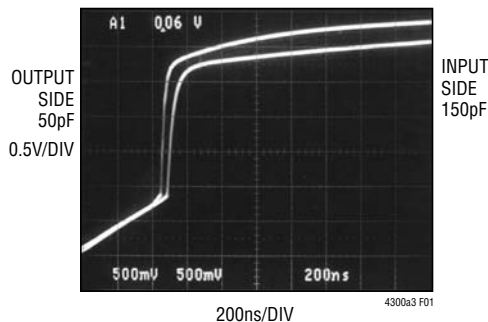

Figure 1. Input–Output Connection Low to High Transition

supply voltage, temperature and the pull-up resistors and equivalent bus capacitances on both sides of the bus. The Typical Performance Characteristics section shows t_{PHL} as a function of temperature and voltage for 10k pull-up resistors and 100pF equivalent capacitance on both sides of the part. By comparison with Figure 2, the $V_{CC} = V_{CC2} = 3.3V$ curve shows that increasing the capacitance from 50pF to 100pF results in a propagation delay increase from 55ns to 75ns. Larger output capacitances translate to longer delays (up to 150ns). Users must quantify the difference in propagation times for a rising edge versus a falling edge in their systems and adjust setup and hold times accordingly.

Rise Time Accelerators

Once connection has been established, rise time accelerator circuits on all four SDA and SCL pins are activated. These allow the user to choose weaker DC pull-up currents on the bus, reducing power consumption while still meeting system rise time requirements. During positive bus transitions, the LTC4300A-3 switches in 2mA (typical) of current to quickly slew the SDA and SCL lines once their DC voltages exceed 0.6V. Using a general rule of 20pF of capacitance for every device on the bus (10pF for the device and 10pF for interconnect), choose a pull-up current so that the bus will rise on its own at a rate of at least 1.25V/ μ s to guarantee activation of the accelerators.

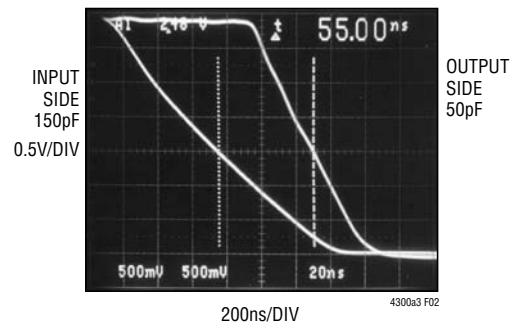

Figure 2. Input–Output Connection High to Low Transition

For example, assume an SMBus system with $V_{CC} = 3V$, a 10k pull-up resistor and equivalent bus capacitance of 200pF. The rise time of an SMBus system is calculated from $(V_{IL(MAX)} - 0.15V)$ to $(V_{IH(MIN)} + 0.15V)$, or 0.65V to 2.25V. It takes an RC circuit 0.92 time constants to traverse this voltage for a 3V supply; in this case, $0.92 \cdot (10k \cdot 200pF) = 1.84\mu s$. Thus, the system exceeds the maximum allowed rise time of 1 μ s by 84%. However, using the rise time accelerators, which are activated at a DC threshold of below 0.65V, the worst-case rise time is: $(2.25V - 0.65V) \cdot 200pF/1mA = 320ns$, which meets the 1 μ s rise time requirement.

ENABLE Low Current Disable

Grounding the ENABLE pin disconnects the backplane side from the card side, disables the rise time accelerators, disables the bus precharge circuitry and puts the part in a near-zero current state. When the pin voltage is driven all the way to V_{CC} , the part waits for data transactions on both the backplane and card sides to be complete (as described in the Start-Up section) before reconnecting the two sides.

APPLICATIONS INFORMATION

Resistor Pull-Up Value Selection

The system pull-up resistors must be strong enough to provide a positive slew rate of $1.25\text{V}/\mu\text{s}$ on the SDA and SCL pins, in order to activate the boost pull-up currents during rising edges. Choose maximum resistor value R using the formula:

$$R \leq (V_{CC(\text{MIN})} - 0.6)(800,000)/C$$

where R is the pull-up resistor value in ohms, $V_{CC(\text{MIN})}$ is the minimum V_{CC} voltage and C is the equivalent bus capacitance in picofarads (pF).

In addition, regardless of the bus capacitance, always choose $R \leq 16\text{k}$ for $V_{CC} = 5.5\text{V}$ maximum, $R \leq 24\text{k}$ for $V_{CC} = 3.6\text{V}$ maximum. The start-up circuitry requires logic high voltages on SDAOUT and SCLOUT to connect the backplane to the card, and these pull-up values are needed to overcome the precharge voltage.

Live Insertion and Capacitance Buffering Application

Figures 3 and 4 illustrate the usage of the LTC4300A-3 in applications that take advantage of both its Hot Swap controlling and capacitance buffering features. In all of these applications, note that if the I/O cards were plugged directly into the backplane, all of the backplane and card capacitances would add directly together, making rise- and fall time requirements difficult to meet. Placing a LTC4300A-3 on the edge of each card, however, isolates the card capacitance from the backplane. For a given I/O card, the LTC4300A-3 drives the capacitance of everything on the card and the backplane must drive only the capacitance of the LTC4300A-3, which is less than 10pF.

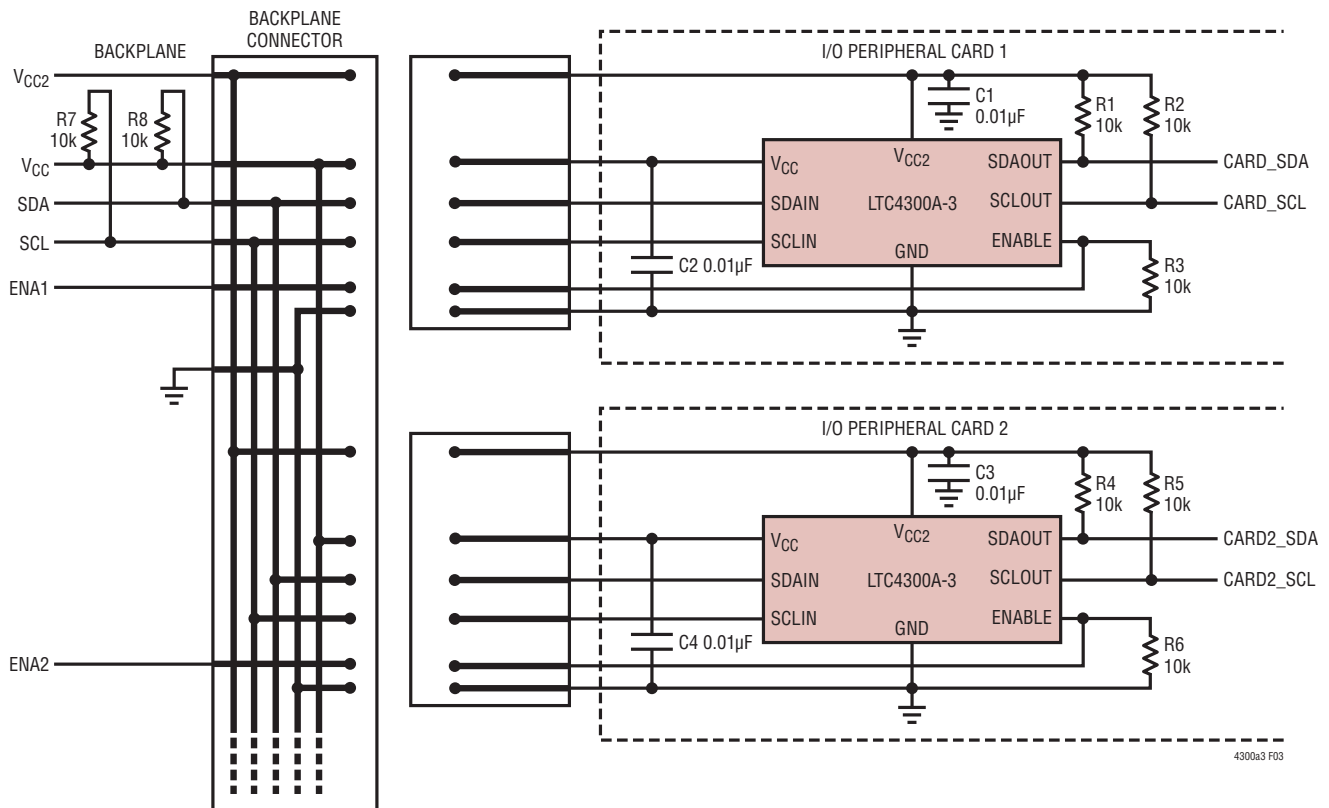

Figure 3. The LTC4300A-3 in a PCI Application Where All the Pins Have the Same Length. ENABLE Should Be Held Low Until All Transients Associated with the Live Insertion Have Settled

APPLICATIONS INFORMATION

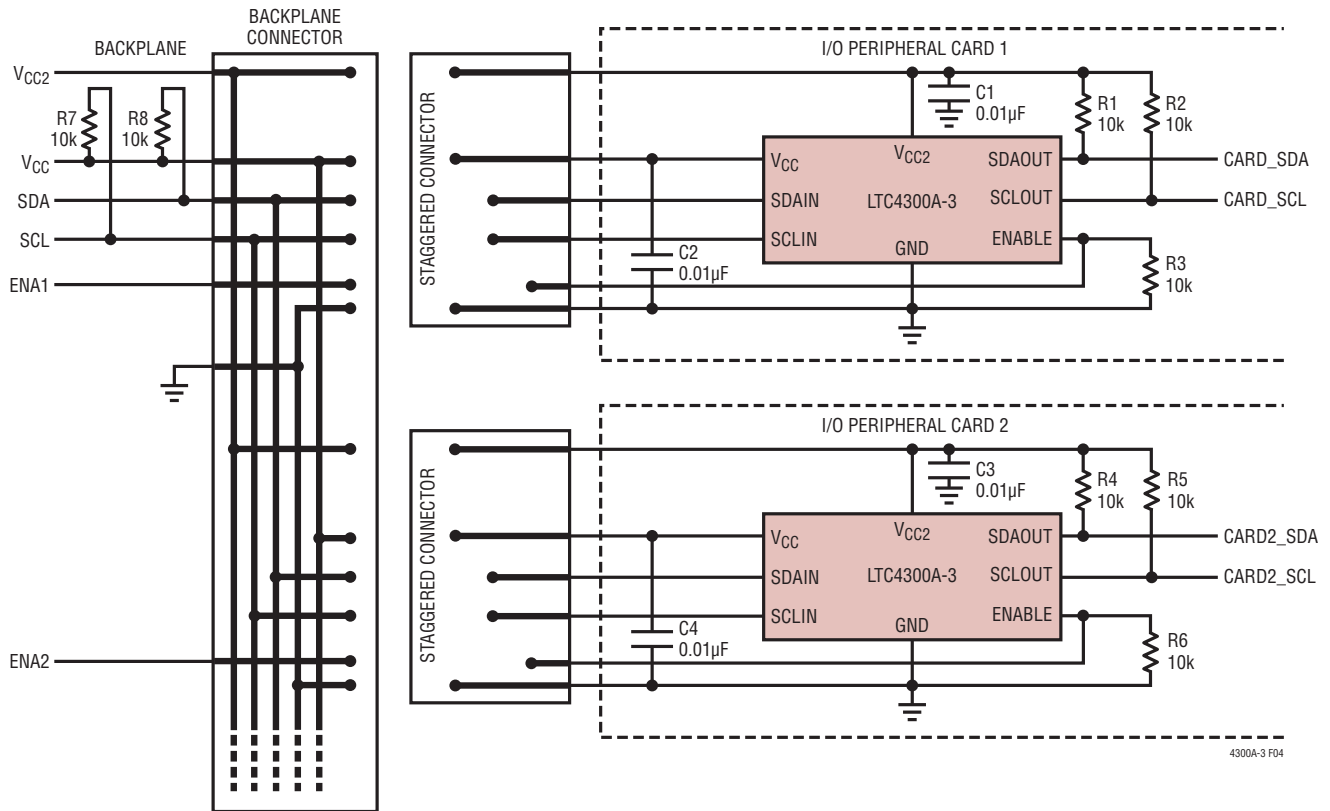

Figure 4. The LTC4300A-3 in a Custom Application. Making ENABLE the Shortest Pin Ensures that V_{CC} and V_{CC2} Connect Before ENABLE is Allowed to Go High, Connecting the Card to the Backplane

5V to 3.3V Level Translator and Power Supply Redundancy

Systems requiring different supply voltages for the backplane side and the card side can use the LTC4300A-3, as shown in Figure 5. The pull-up resistors on the card side connect from SDAOUT to SCLOUT to V_{CC2} , and those on the backplane side connect from SDAIN and SCLIN to V_{CC} . The LTC4300A-3 functions for voltages ranging from 2.7V to 5.5V on both V_{CC} and V_{CC2} . There is no constraint on the voltage magnitudes of V_{CC} and V_{CC2} with respect to each other.

This application also provides power supply redundancy. If the V_{CC2} voltage falls below its UVLO threshold, the LTC4300A-3 disconnects the backplane from the card, so that the backplane can continue to function. If the V_{CC} voltage falls below its UVLO threshold and the V_{CC2} voltage remains active, hold ENABLE at ground to ensure proper operation.

PACKAGE DESCRIPTION

Please refer to <http://www.linear.com/designtools/packaging/> for the most recent package drawings.

MS8 Package
8-Lead Plastic MSOP
 (Reference LTC DWG # 05-08-1660 Rev F)

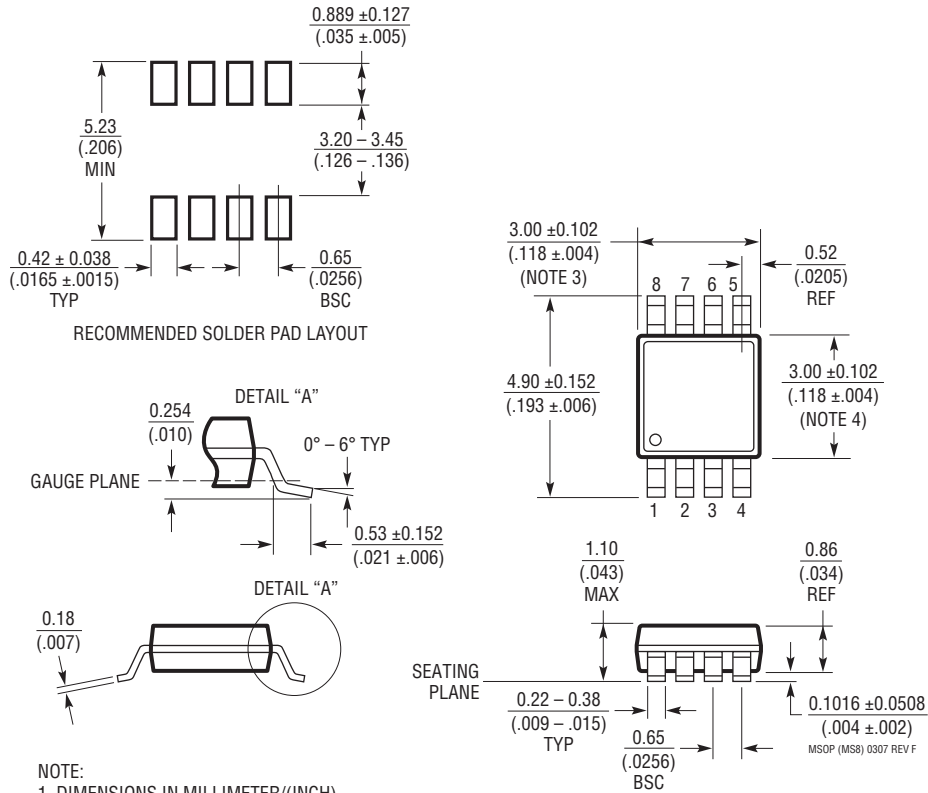

NOTE:

1. DIMENSIONS IN MILLIMETER/(INCH)
2. DRAWING NOT TO SCALE
3. DIMENSION DOES NOT INCLUDE MOLD FLASH, PROTRUSIONS OR GATE BURRS.
MOLD FLASH, PROTRUSIONS OR GATE BURRS SHALL NOT EXCEED 0.152mm (.006") PER SIDE
4. DIMENSION DOES NOT INCLUDE INTERLEAD FLASH OR PROTRUSIONS.
INTERLEAD FLASH OR PROTRUSIONS SHALL NOT EXCEED 0.152mm (.006") PER SIDE
5. LEAD COPLANARITY (BOTTOM OF LEADS AFTER FORMING) SHALL BE 0.102mm (.004") MAX

REVISION HISTORY

REV	DATE	DESCRIPTION	PAGE NUMBER
A	09/12	Updated format of Pin Configuration and Order Information sections	2
		Added $T_{PHL,SKEW}$ parameter to Electrical Characteristics	3

TYPICAL APPLICATION

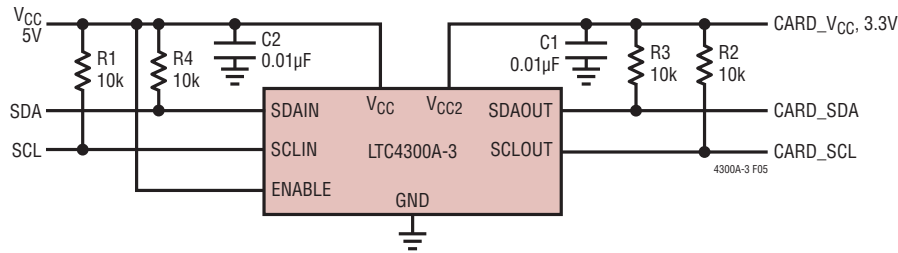

Figure 5. 5V to 3.3V Level Translator

RELATED PARTS

PART NUMBER	DESCRIPTION	COMMENTS
LTC1380/LTC1393	Single-Ended 8-Channel/Differential 4-Channel Analog Mux with SMBus Interface	Low R_{ON} : 35Ω Single-Ended/70Ω Differential, Expandable to 32 Single or 16 Differential Channels
LTC1427-50	Micropower, 10-Bit Current Output DAC with SMBus Interface	Precision 50µA ± 2.5% Tolerance Over Temperature, 4 Selectable SMBus Addresses, DAC Powers Up at Zero or Mid-Scale
LTC1623	Dual High Side Switch Controller with SMBus Interface	8 Selectable Addresses/16-Channel Capability
LTC1663	SMBus Interface 10-Bit Rail-to-Rail Micropower DAC	DNL < 0.75LSB Max, 5-Lead SOT-23 Package
LTC1694/LTC1694-1	SMBus Accelerator	Improved SMBus/I ² C Rise Time, Ensures Data Integrity with Multiple SMBus/I ² C Devices
LT1786F	SMBus Controlled CCFL Switching Regulator	1.25A, 200kHz, Floating or Grounded Lamp Configurations
LTC1695	SMBus/I ² C Fan Speed Controller in ThinSOT™	0.75Ω PMOS 180mA Regulator, 6-Bit DAC
LTC1840	Dual I ² C Fan Speed Controller	Two 100µA 8-Bit DACs, Two Tach Inputs, Four GPIO
LTC4300A-1/ LTC4300A-2	Hot Swappable 2-Wire Bus Buffer	Preserves Data Integrity Under Hot Swap Conditions, Provides Capacitive Buffering, Rise Time Acceleration
LTC4301	Supply Independent 2-Wire Bus Buffer	Provides Capacitive Buffer, 3.3V to 5V Level Translation with Only the Card Bus V _{CC} Supply
LTC4301L	Hot-Swappable 2-Wire Bus Buffer with Low Voltage Level Translation	Level Translators, 1V Signals to Standard 3.3V and 5V Logic Rails
LTC4302-1/ LTC4302-2	Addressable I ² C and SMBus Compatible Bus Buffers	Provides Capacitive Buffering, Rise time Acceleration, and Input to Output Connection Control Using 2-Wire Bus Commands

Looking for pricing, stock, or lifecycle information?

Click below to explore more details on WIN SOURCE:

 [View LTC4300A-3CDD#PBF on WIN SOURCE](#)

 [Linear Technology](#) Information

Optimize Your Supply Chain with WIN SOURCE Solutions

-  Global Sourcing Solution
-  Obsolete Management
-  Cost Control Management
-  Shortage Management
-  Alternative Solution
-  Excess Inventory Management