



**THE DATASHEET OF
LTC4090EDJC#TRPBF**



USB Power Manager with 2A High Voltage Bat-Track Buck Regulator

FEATURES

- **Seamless Transition Between Power Sources: Li-Ion Battery, USB, and 6V to 36V Supply (60V Max)**
- **2A Output High Voltage Buck Regulator with Bat-Track™ Adaptive Output Control (LTC4090)**
- **Internal 215mΩ Ideal Diode Plus Optional External Ideal Diode Controller Provides Low Loss PowerPath™ When External Supply/USB Not Present**
- Load Dependent Charging from USB Input Guarantees Current Compliance
- Full Featured Li-Ion Battery Charger
- 1.5A Maximum Charge Current with Thermal Limiting
- NTC Thermistor Input for Temperature Qualified Charging
- Tiny (3mm × 6mm × 0.75mm) 22-Pin DFN Package

APPLICATIONS

- HDD-Based Media Players
- Personal Navigation Devices
- Other USB-Based Handheld Products
- Automotive Accessories

DESCRIPTION

The **LTC®4090/LTC4090-5** are USB power managers plus high voltage Li-Ion/Polymer battery chargers. The devices control the total current used by the USB peripheral for operation and battery charging. Battery charge current is automatically reduced such that the sum of the load current and the charge current does not exceed the programmed input current limit. The LTC4090/LTC4090-5 also accommodate high voltage power supplies, such as 12V AC/DC wall adapters, Firewire, or automotive power.

The LTC4090 provides a Bat-Track adaptive output that tracks the battery voltage for high efficiency charging from the high voltage input. The LTC4090-5 provides a fixed 5V output from the high voltage input to charge single-cell Li-Ion batteries. The charge current is programmable and an end-of-charge status output ($\overline{\text{CHRG}}$) indicates full charge. Also featured are programmable total charge time, an NTC thermistor input used to monitor battery temperature while charging and automatic recharging of the battery.

LT, LT, LTC, LTM, Linear Technology, the Linear logo and Burst Mode are registered trademarks and Bat-Track, PowerPath and ThinSOT are trademarks of Analog Devices, Inc. All other trademarks are the property of their respective owners.

TYPICAL APPLICATION

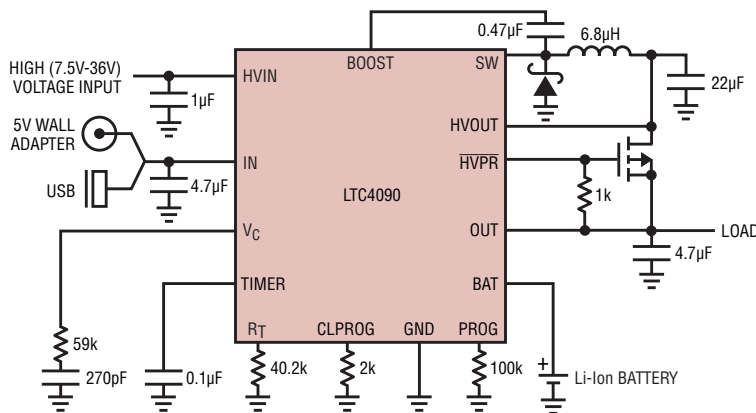

V _{OUT} (TYP)	AVAILABLE INPUT
V _{BAT} + 0.3V	HV INPUT (LTC4090)
5V	HV INPUT (LTC4090-5)
5V	USB ONLY
V _{BAT}	BAT ONLY

4090 TA01

LTC4090/LTC4090-5 High Voltage Battery Charger Efficiency

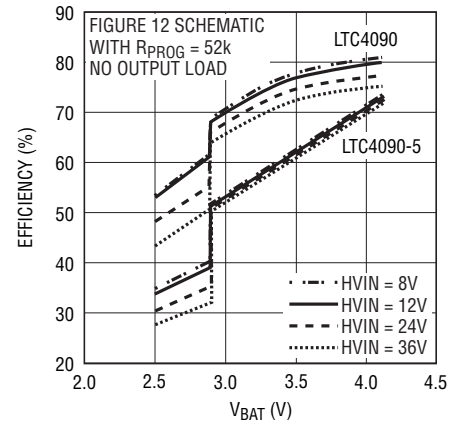

4090 TA01b

LTC4090/LTC4090-5

ABSOLUTE MAXIMUM RATINGS

(Notes 1, 2, 3, 4)

HVIN, HVEN (Note 9)	60V
BOOST	56V
BOOST above SW	30V
PG, SYNC	30V
IN, OUT, HVOUT	
t < 1ms and Duty Cycle < 1%	-0.3V to 7V
Steady State	-0.3V to 6V
BAT, HPWR, SUSP, V _C , CHRG, HVPR	-0.3V to 6V
NTC, TIMER, PROG, CLPROG	-0.3V to V _{CC} + 0.3V
I _{IN} , I _{OUT} , I _{BAT} (Note 5)	2.5A
Operating Temperature Range	-40 to 85°C
Junction Temperature	110°C
Storage Temperature Range	-65 to 125°C

PIN CONFIGURATION

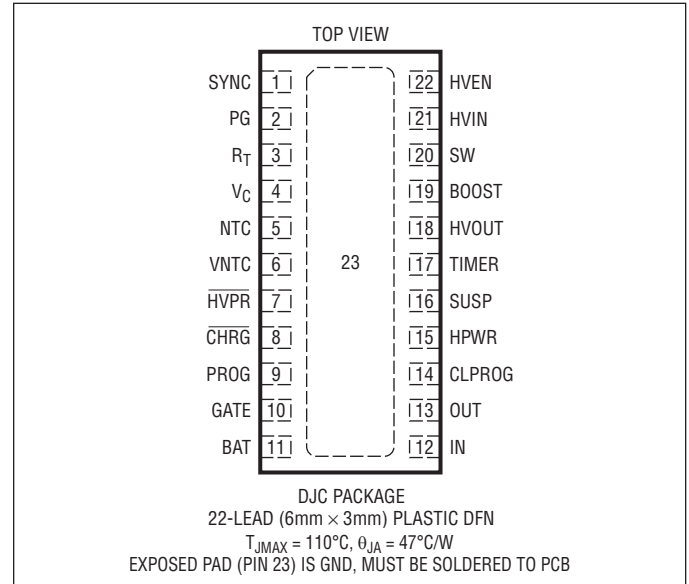

ORDER INFORMATION

<http://www.linear.com/product/LTC4090#orderinfo>

LEAD FREE FINISH	TAPE AND REEL	PART MARKING	PACKAGE DESCRIPTION	TEMPERATURE RANGE
LTC4090EDJC#PBF	LTC4090EDJC#TRPBF	4090	22-Lead (6mm × 3mm) Plastic DFN	-40°C to 85°C
LTC4090EDJC-5#PBF	LTC4090EDJC-5#TRPBF	40905	22-Lead (6mm × 3mm) Plastic DFN	-40°C to 85°C

Consult LTC Marketing for parts specified with wider operating temperature ranges.

For more information on lead free part marking, go to: <http://www.linear.com/leadfree/>

For more information on tape and reel specifications, go to: <http://www.linear.com/tapeandree/>. Some packages are available in 500 unit reels through designated sales channels with #TRMPBF suffix.

ELECTRICAL CHARACTERISTICS

The ● denotes the specifications which apply over the full operating temperature range, otherwise specifications are at T_A = 25°C. HVIN = HVEN = 12V, BOOST = 17V, V_{IN} = HPWR = 5V, V_{BAT} = 3.7V, R_{PROG} = 100k, R_{CLPROG} = 2k and SUSP = 0V, unless otherwise noted.

SYMBOL	PARAMETER	CONDITIONS	MIN	TYP	MAX	UNITS	
USB Input Current Limit							
V _{IN}	USB Input Supply Voltage		● 4.35		5.5	V	
I _{IN}	Input Bias Current	I _{BAT} = 0 (Note 6) Suspend Mode; SUSP = 5V	●	0.5	1	mA	
			●	50	100	μA	
I _{LIM}	Current Limit	HPWR = 5V HPWR = 0V	●	475	500	mA	
			●	90	100	mA	
I _{IN(MAX)}	Maximum Input Current Limit	(Note 7)		2.4		A	
R _{ON}	On-Resistance V _{IN} to V _{OUT}	I _{OUT} = 80mA		0.215		Ω	
V _{CLPROG}	CLPROG Servo Voltage in Current Limit	R _{CLPROG} = 2k R _{CLPROG} = 1k	●	0.98	1.00	1.02	V
			●	0.98	1.00	1.02	V
I _{SS}	Soft-Start Inrush Current			10		mA/μs	

4090fe

ELECTRICAL CHARACTERISTICS The ● denotes the specifications which apply over the full operating temperature range, otherwise specifications are at $T_A = 25^\circ\text{C}$. $\text{HVIN} = \text{HVEN} = 12\text{V}$, $\text{BOOST} = 17\text{V}$, $\text{VIN} = \text{HPWR} = 5\text{V}$, $\text{VBAT} = 3.7\text{V}$, $\text{R}_{\text{PROG}} = 100\text{k}$, $\text{R}_{\text{CLPROG}} = 2\text{k}$ and $\text{SUSP} = 0\text{V}$, unless otherwise noted.

SYMBOL	PARAMETER	CONDITIONS	MIN	TYP	MAX	UNITS
V_{CLEN}	Input Current Limit Enable Threshold Voltage ($V_{\text{IN}} - V_{\text{OUT}}$)	$(V_{\text{IN}} - V_{\text{OUT}})$ Rising	20	50	80	mV
		$(V_{\text{IN}} - V_{\text{OUT}})$ Falling	-80	-50	-20	mV
V_{UVLO}	Input Undervoltage Lockout	V_{IN} Rising	● 3.6	3.8	4	V
ΔV_{UVLO}	Input Undervoltage Lockout Hysteresis	V_{IN} Rising – V_{IN} Falling		130		mV
High Voltage Regulator						
V_{HVIN}	HVIN Supply Voltage		● 6		60	V
V_{OVLO}	HVIN Overvoltage Lockout Threshold		● 36	38	40	V
I_{HVIN}	HVIN Bias Current	Shutdown; $\text{HVEN} = 0.2\text{V}$ Not Switching, $\text{HVOOUT} = 3.6\text{V}$	●	0.01	0.5	μA
				130	200	μA
V_{OUT}	Output Voltage with HVIN Present	Assumes HVOOUT to OUT Connection, $0 \leq V_{\text{BAT}} \leq 4.2\text{V}$ (LTC4090)	3.45	$V_{\text{BAT}} + 0.3$	4.6	V
V_{OUT}	Output Voltage with HVIN Present	Assumes HVOOUT to OUT Connection (LTC4090-5)	4.85	5	5.15	V
f_{SW}	Switching Frequency	$R_T = 8.66\text{k}$ $R_T = 29.4\text{k}$ $R_T = 187\text{k}$	2.1	2.4	2.7	MHz
			0.9	1.0	1.15	MHz
			160	200	240	kHz
t_{OFF}	Minimum Switch Off-Time		●	60	150	ns
$I_{\text{SW(MAX)}}$	Switch Current Limit	Duty Cycle = 5%	3.0	3.5	4.0	A
V_{SAT}	Switch V_{CESAT}	$I_{\text{SW}} = 2\text{A}$		500		mV
I_{R}	Boost Schottky Reverse Leakage	$\text{SW} = 10\text{V}$, $\text{HVOOUT} = 0\text{V}$		0.02	2	μA
$V_{\text{B(MIN)}}$	Minimum Boost Voltage (Note 8)		●	1.5	2.1	V
I_{BST}	BOOST Pin Current	$I_{\text{SW}} = 1\text{A}$		22	35	mA
Battery Management						
I_{BAT}	Battery Drain Current	$V_{\text{BAT}} = 4.3\text{V}$, Charging Stopped Suspend Mode, $\text{SUSP} = 5\text{V}$ $V_{\text{IN}} = 0\text{V}$, BAT Powers OUT, No Load	●	15	27	μA
			●	22	35	μA
			●	60	100	μA
V_{FLOAT}	V_{BAT} Regulated Output Voltage	$I_{\text{BAT}} = 2\text{mA}$ $I_{\text{BAT}} = 2\text{mA}$; $0 \leq T_A \leq 85^\circ\text{C}$	4.165	4.200	4.235	V
			4.158	4.200	4.242	V
I_{CHG}	Constant-Current Mode Charge Current, No Load	$\text{R}_{\text{PROG}} = 100\text{k}$ $\text{R}_{\text{PROG}} = 50\text{k}$, $0 \leq T_A \leq 85^\circ\text{C}$	● 465	500	535	mA
				900	1080	mA
$I_{\text{CHG(MAX)}}$	Maximum Charge Current			1.5		A
V_{PROG}	PROG Pin Servo Voltage	$\text{R}_{\text{PROG}} = 100\text{k}$ $\text{R}_{\text{PROG}} = 50\text{k}$	● 0.98	1.00	1.02	V
			●	0.98	1.00	1.02
k_{EOC}	Ratio of End-of-Charge Indication Current to Charge Current	$V_{\text{BAT}} = V_{\text{FLOAT}} (4.2\text{V})$	● 0.085	0.1	0.11	mA/mA
I_{TRKL}	Trickle Charge Current	BAT = 2V	35	50	60	mA
V_{TRKL}	Trickle Charge Threshold Voltage	BAT Rising	● 2.75	2.9	3.0	V
V_{CEN}	Charge Enable Threshold Voltage	$(V_{\text{OUT}} - V_{\text{BAT}})$ Falling; $V_{\text{BAT}} = 4\text{V}$ $(V_{\text{OUT}} - V_{\text{BAT}})$ Rising; $V_{\text{BAT}} = 4\text{V}$		55		mV
				80		mV
ΔV_{RECHRG}	Recharge Battery Threshold Voltage	Threshold Voltage Relative to V_{FLOAT}	● -65	-100	-135	mV

LTC4090/LTC4090-5

ELECTRICAL CHARACTERISTICS The ● denotes the specifications which apply over the full operating temperature range, otherwise specifications are at $T_A = 25^\circ\text{C}$. $HVIN = HVEN = 12\text{V}$, $BOOST = 17\text{V}$, $V_{IN} = HPWR = 5\text{V}$, $V_{BAT} = 3.7\text{V}$, $R_{PROG} = 100\text{k}$, $R_{CLPROG} = 2\text{k}$ and $SUSP = 0\text{V}$, unless otherwise noted.

SYMBOL	PARAMETER	CONDITIONS	MIN	TYP	MAX	UNITS
t_{TIMER}	TIMER Accuracy	$V_{BAT} = 4.3\text{V}$	-10		10	%
	Recharge Time	Percent of Total Charge Time		50		%
	Low Battery Trickle Charge Time	Percent of Total Charge Time, $V_{BAT} < 2.9\text{V}$		25		%
T_{LIM}	Junction Temperature in Constant-Temperature Mode			105		$^\circ\text{C}$

Internal Ideal Diode

R_{FWD}	Incremental Resistance, V_{ON} Regulation	$I_{OUT} = 100\text{mA}$		125		$\text{m}\Omega$
$R_{DIO, ON}$	On-Resistance V_{BAT} to V_{OUT}	$I_{OUT} = 600\text{mA}$		215		$\text{m}\Omega$
V_{FWD}	Voltage Forward Drop ($V_{BAT} - V_{OUT}$)	$I_{OUT} = 5\text{mA}$ $I_{OUT} = 100\text{mA}$ $I_{OUT} = 600\text{mA}$	● 10	30 55 160	50	mV mV mV
V_{OFF}	Diode Disable Battery Voltage			2.7		V
I_{FWD}	Load Current Limit for V_{ON} Regulation			550		mA
$I_{D(MAX)}$	Diode Current Limit			2.2		A

External Ideal Diode

$V_{FWD, EXT}$	External Diode Forward Voltage			20		mV
----------------	--------------------------------	--	--	----	--	----

Logic (CHRG, HVPR, TIMER, SUSP, HPWR, HVEN, PG, SYNC)

$V_{CHG, SD}$	Charger Shutdown Threshold Voltage on TIMER		● 0.14		0.4	V
$I_{CHG, SD}$	Charger Shutdown Pull-Up Current on TIMER	$V_{TIMER} = 0\text{V}$	● 5	14		μA
V_{OL}	Output Low Voltage	(CHRG, HVPR); $I_{SINK} = 5\text{mA}$	●	0.1	0.4	V
V_{IH}	Input High Voltage	SUSP, HPWR		1.2		V
V_{IL}	Input Low Voltage	SUSP, HPWR			0.4	V
$V_{HVEN, H}$	HVEN High Threshold			2.3		V
$V_{HVEN, L}$	HVEN Low Threshold				0.3	V
I_{PULLDN}	Logic Input Pull-Down Current	SUSP, HPWR		2		μA
I_{HVEN}	HVEN Pin Bias Current	$HVEN = 2.5\text{V}$		5	10	μA
V_{PG}	PG Threshold	HVOUT Rising		2.8		V
ΔV_{PG}	PG Hysteresis			35		mV
I_{PGLK}	PG Leakage	$PG = 5\text{V}$		0.1	1	μA
I_{PG}	PG Sink Current	$PG = 0.4\text{V}$	● 100	900		μA
$V_{SYNC, L}$	SYNC Low Threshold		0.5			V
$V_{SYNC, H}$	SYNC High Threshold				0.8	V
I_{SYNC}	SYNC Pin Bias Current	$V_{SYNC} = 0\text{V}$		0.1		μA

ELECTRICAL CHARACTERISTICS

The ● denotes the specifications which apply over the full operating temperature range, otherwise specifications are at $T_A = 25^\circ\text{C}$. $HVIN = HVEN = 12\text{V}$, $BOOST = 17\text{V}$, $V_{IN} = HPWR = 5\text{V}$, $V_{BAT} = 3.7\text{V}$, $R_{PROG} = 100\text{k}$, $R_{CLPROG} = 2\text{k}$ and $SUSP = 0\text{V}$, unless otherwise noted.

SYMBOL	PARAMETER	CONDITIONS	MIN	TYP	MAX	UNITS
NTC						
I_{VNTC}	VNTC Pin Current	$V_{VNTC} = 2.5\text{V}$	1.4	2.5	3.5	mA
V_{VNTC}	VNTC Bias Voltage	$I_{VNTC} = 500\mu\text{A}$	● 4.4	4.85		V
I_{NTC}	NTC Input Leakage Current	$NTC = 1\text{V}$		0	± 1	μA
V_{COLD}	Cold Temperature Fault Threshold Voltage	Rising NTC Voltage Hysteresis		$0.738 \cdot V_{VNTC}$		V
			$0.02 \cdot V_{VNTC}$		V	
V_{HOT}	Hot Temperature Fault Threshold Voltage	Falling NTC Voltage Hysteresis		$0.29 \cdot V_{VNTC}$		V
			$0.01 \cdot V_{VNTC}$		V	
V_{DIS}	NTC Disable Threshold Voltage	Falling NTC Voltage Hysteresis	● 75	100 35	125	mV mV

Note 1: Stresses beyond those listed under Absolute Maximum Ratings may cause permanent damage to the device. Exposure to any Absolute Maximum Rating condition for extended periods may affect device reliability and lifetime.

Note 2: The LTC4090/LTC4090-5 are guaranteed to meet performance specifications from 0°C to 85°C . Specifications over the -40°C to 85°C operating temperature range are assured by design, characterization and correlation with statistical process controls.

Note 3: This IC includes overtemperature protection that is intended to protect the device during momentary overload conditions. Junction temperatures will exceed 110°C when overtemperature protection is active. Continuous operation above the specified maximum operating junction temperature may result in device degradation or failure.

Note 4: V_{CC} is the greater of V_{IN} , V_{OUT} , and V_{BAT}

Note 5: Guaranteed by long term current density limitations.

Note 6: Total input current is equal to this specification plus $1.002 \cdot I_{BAT}$ where I_{BAT} is the charge current.

Note 7: Accuracy of programmed current may degrade for currents greater than 1.5A.

Note 8: This is the minimum voltage across the boost capacitor needed to guarantee full saturation of the switch.

Note 9: Absolute Maximum Voltage at $HVIN$ and $HVEN$ pins is for nonrepetitive 1 second transients; 40V for continuous operation.

TYPICAL PERFORMANCE CHARACTERISTICS

V_{FLOAT} Load Regulation

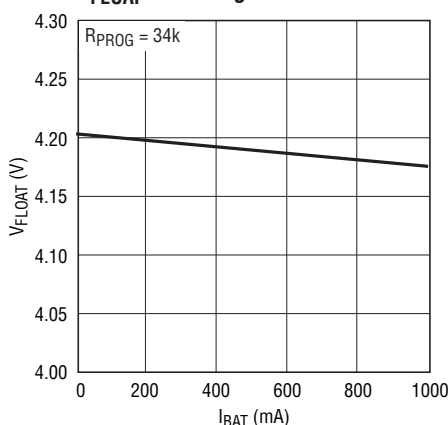

4090 G01

Battery Regulation (Float) Voltage vs Temperature

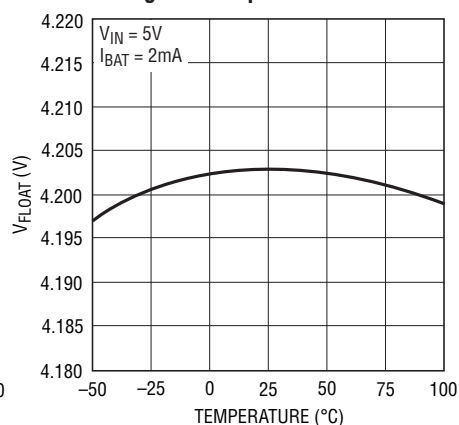

4090 G02

Battery Current and Voltage vs Time (LTC4090)

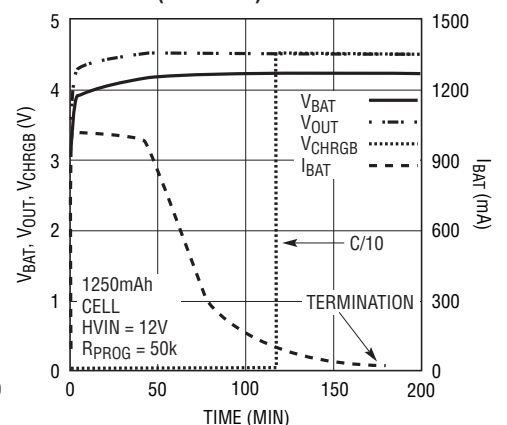

4090 G03

4090fe

TYPICAL PERFORMANCE CHARACTERISTICS

Charging from USB, I_{BAT} vs V_{BAT}

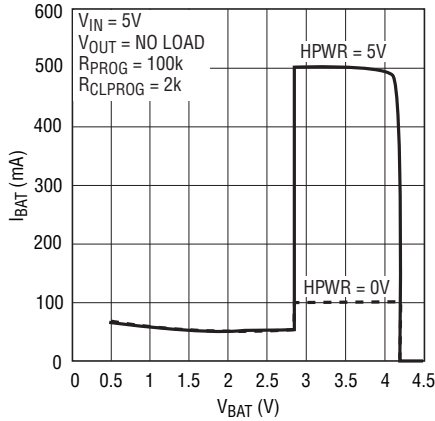

4090 G04

Charge Current vs Temperature (Thermal Regulation)

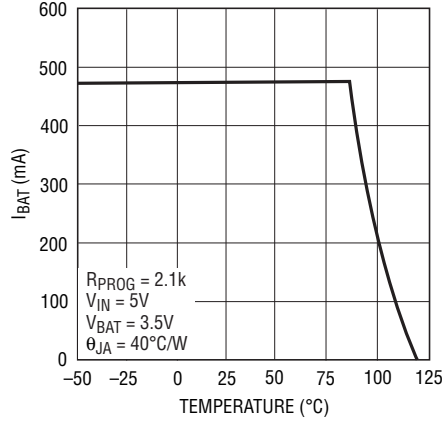

4090 G05

Ideal Diode Current vs Forward Voltage and Temperature (No External Device)

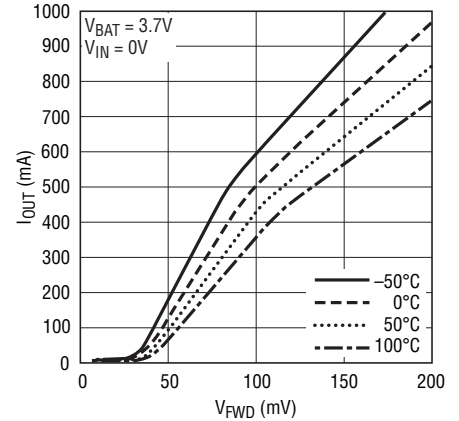

4090 G06

Ideal Diode Current vs Forward Voltage and Temperature with External Device

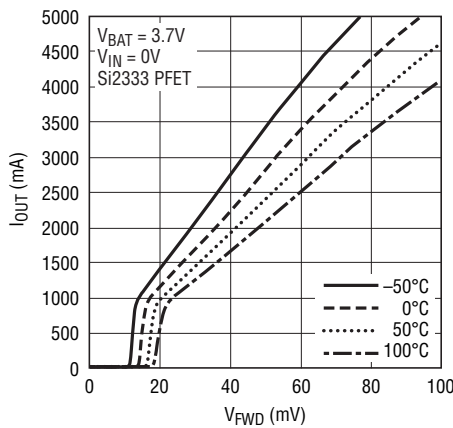

4090 G07

LTC4090 High Voltage Regulator Efficiency vs Output Load

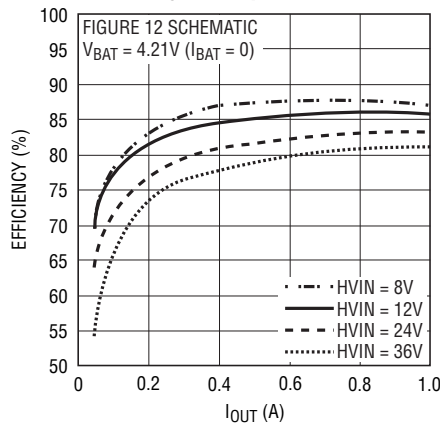

4090 G08

LTC4090-5 High Voltage Regulator Efficiency vs Output Load

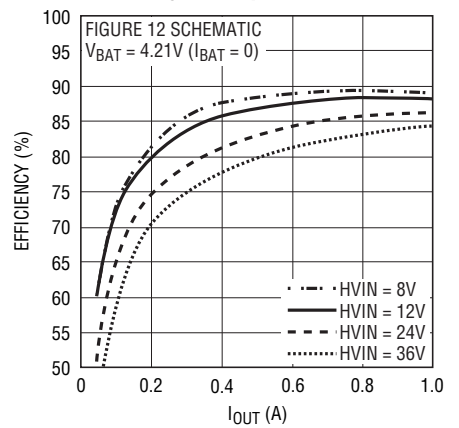

4090 G09

High Voltage Regulator Maximum Load Current

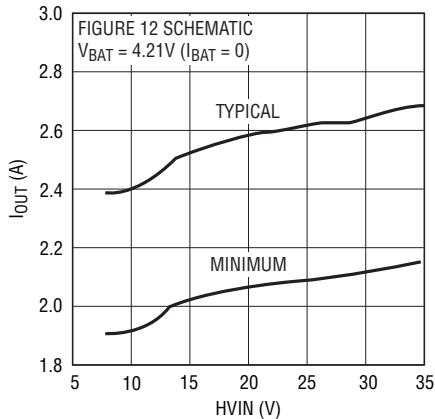

4090 G10

High Voltage Regulator Minimum Switch On-Time vs Temperature

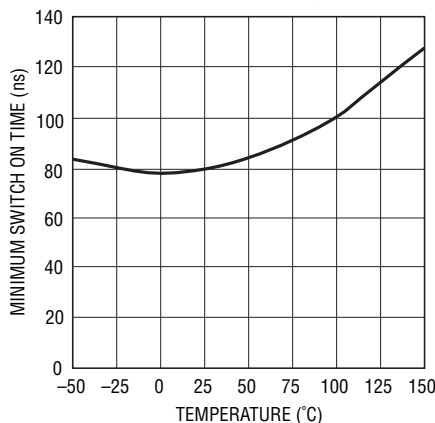

4090 G11

High Voltage Regulator Switch Voltage Drop

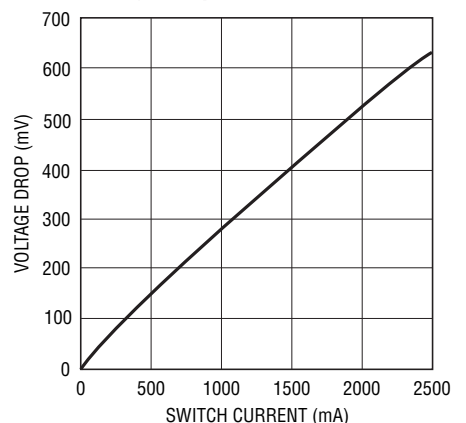

4090 G12

TYPICAL PERFORMANCE CHARACTERISTICS

High Voltage Regulator Switch Frequency

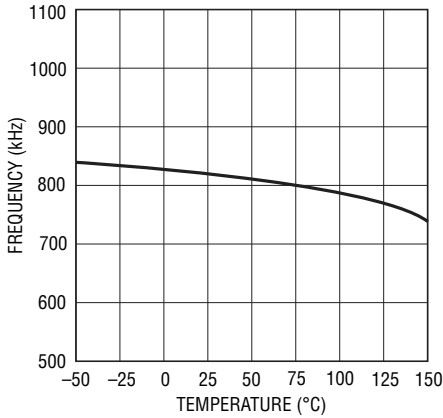

4090 G13

High Voltage Regulator Frequency Foldback

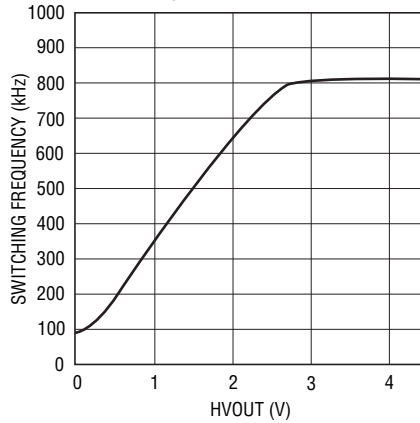

4090 G14

High Voltage Regulator Soft-Start

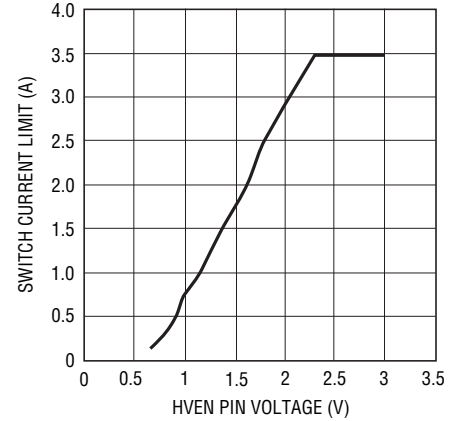

4090 G15

High Voltage Regulator Switch Current Limit

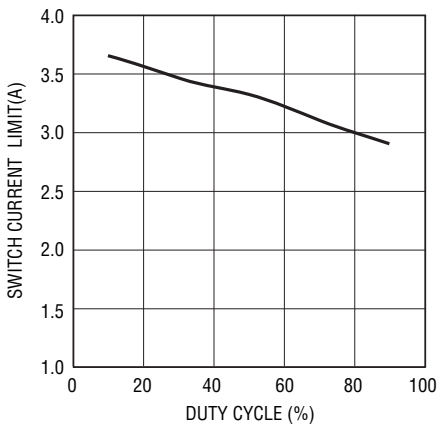

4090 G16

High Voltage Regulator Switch Current Limit

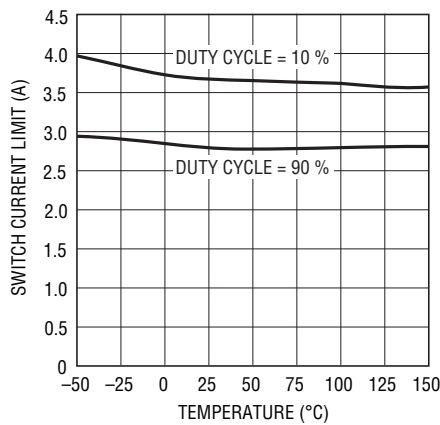

4090 G17

High Voltage Regulator Minimum Input Voltage

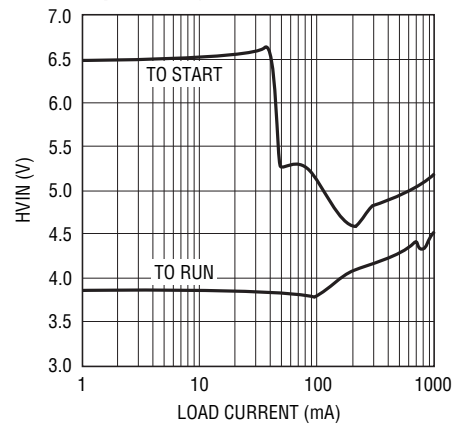

4090 G18

High Voltage Regulator Boost Diode V_F vs I_F

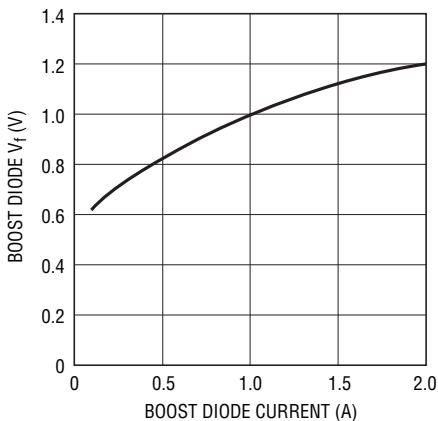

4090 G19

High Voltage Regulator V_C Voltages

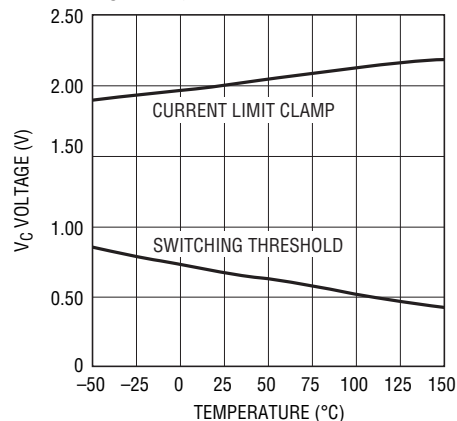

4090 G20

High Voltage Regulator Power Good Threshold

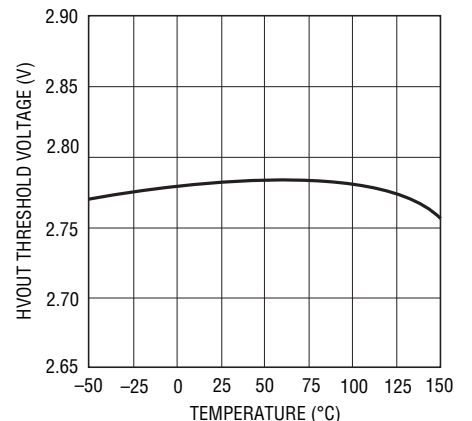

4090 G21

TYPICAL PERFORMANCE CHARACTERISTICS

LTC4090 Input Connect Waveforms

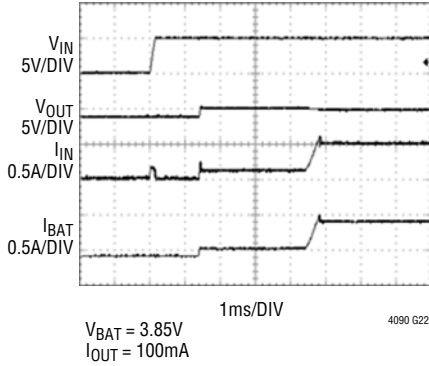

LTC4090 Input Disconnect Waveforms

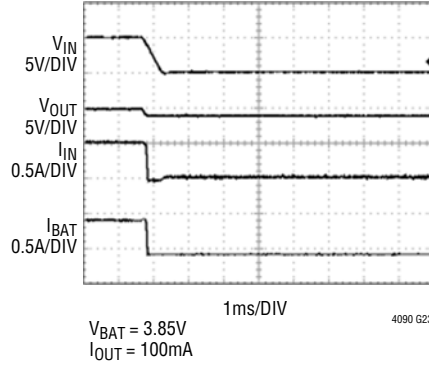

LTC4090 Response to Suspend

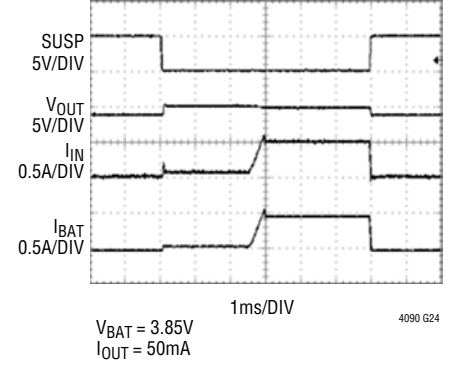

LTC4090 High Voltage Input Connect Waveforms

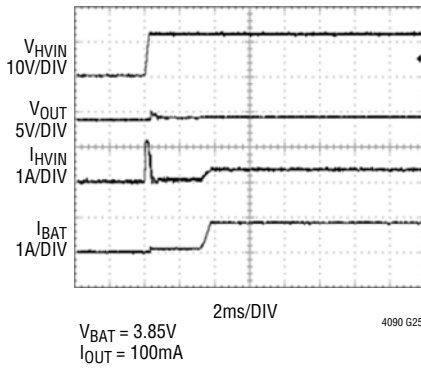

LTC4090 High Voltage Input Disconnect Waveforms

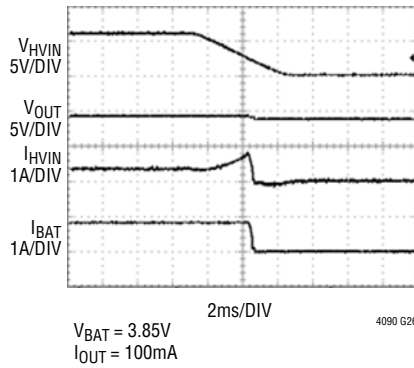

LTC4090 Response to HPWR

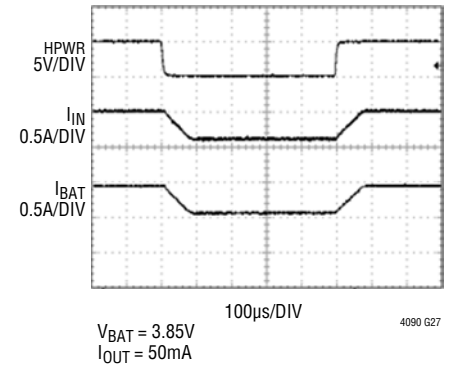

LTC4090 High Voltage Regulator Load Transient

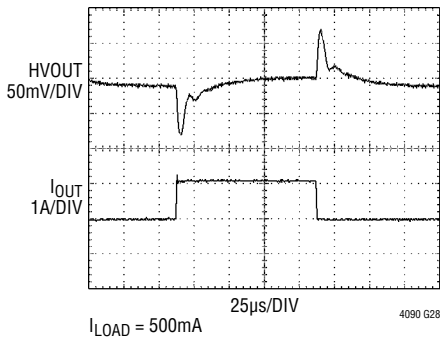

LTC4090 High Voltage Regulator Load Transient

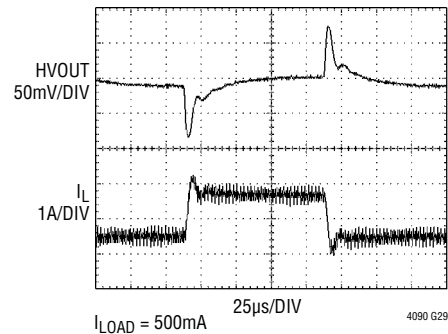

PIN FUNCTIONS

SYNC (Pin 1): External Clock Synchronization Input. See synchronizing section in the Applications Information section. Ground pin when not used.

PG (Pin 2): Open Collector Output of an Internal Comparator. PG remains low until the HVOUT pin is above 2.8V. PG output is valid when HVIN is above 3.6V and HVEN is high.

R_T (Pin 3): Oscillator Resistor Input. Connecting a resistor to ground from this pin sets the switching frequency.

V_C (Pin 4): High Voltage Buck Regulator Control Pin. The voltage on this pin controls the peak switch current in the high voltage regulator. Tie an RC network from this pin to ground to compensate the control loop.

NTC (Pin 5): Input to the NTC Thermistor Monitoring Circuits. The NTC pin connects to a negative temperature coefficient thermistor which is typically co-packaged with the battery pack to determine if the battery is too hot or too cold to charge. If the battery temperature is out of range, charging is paused until the battery temperature re-enters the valid range. A low drift bias resistor is required from VNTC to NTC and a thermistor is required from NTC to ground. If the NTC function is not desired, the NTC pin should be grounded.

VNTC (Pin 6): Output Bias Voltage for NTC. A resistor from this pin to the NTC pin will bias the NTC thermistor.

HVPR (Pin 7): High Voltage Present Output (Active Low). A low on this pin indicates that the high voltage regulator has sufficient voltage to charge the battery. This feature is enabled if power is present on HVIN, IN, or BAT (i.e., above UVLO thresholds).

CHRG (Pin 8): Open-Drain Charge Status Output. When the battery is being charged, the CHRG pin is pulled low by an internal N-channel MOSFET. When the timer runs out or the charge current drops below 10% of the programmed charge current or the input supply is removed, the CHRG pin is forced to a high impedance state.

PROG (Pin 9): Charge Current Program Pin. Connecting a resistor from PROG to ground programs the charge current:

$$I_{\text{CHG}}(\text{A}) = \frac{50,000\text{V}}{R_{\text{PROG}}}$$

GATE (Pin 10): External Ideal Diode Gate Connection. This pin controls the gate of an optional external P-channel MOSFET transistor used to supplement the internal ideal diode. The source of the P-channel MOSFET should be connected to OUT and the drain should be connected to BAT. When not in use, this pin should be left floating. It is important to maintain high impedance on this pin and minimize all leakage paths.

BAT (Pin 11): Single-Cell Li-Ion Battery. This pin is used as an output when charging the battery and as an input when supplying power to OUT. When the OUT pin potential drops below the BAT pin potential, an ideal diode function connects BAT to OUT and prevents OUT from dropping more than 100mV below BAT. A precision internal resistor divider sets the final float (charging) potential on this pin. The internal resistor divider is disconnected when IN and HVIN are in undervoltage lockout.

IN (Pin 12): Input Supply. Connect to USB supply, V_{BUS}. Input current to this pin is limited to either 20% or 100% of the current programmed by the CLPROG pin as determined by the state of the HPWR pin. Charge current (to the BAT pin) supplied through the input is set to the current programmed by the PROG pin but will be limited by the input current limit if charge current is set greater than the input current limit or if the sum of charge current plus load current is greater than the input current limit.

OUT (Pin 13): Voltage Output. This pin is used to provide controlled power to a USB device from either USB V_{BUS} (IN), an external high voltage supply (HVIN), or the battery (BAT) when no other supply is present. The high voltage supply is prioritized over the USB V_{BUS} input. OUT should be bypassed with at least 4.7μF to GND.

PIN FUNCTIONS

CLPROG (Pin 14): Current Limit Program and Input Current Monitor. Connecting a resistor, R_{CLPROG} , to ground programs the input to output current limit. The current limit is programmed as follows:

$$I_{CL}(A) = \frac{1000V}{R_{CLPROG}}$$

In USB applications, the resistor R_{CLPROG} should be set to no less than 2.1k. The voltage on the CLPROG pin is always proportional to the current flowing through the IN to OUT power path. This current can be calculated as follows:

$$I_{IN}(A) = \frac{V_{CLPROG}}{R_{CLPROG}} \cdot 1000$$

HPWR (Pin 15): High Power Select. This logic input is used to control the input current limit. A voltage greater than 1.2V on the pin will set the input current limit to 100% of the current programmed by the CLPROG pin. A voltage less than 0.4V on the pin will set the input current limit to 20% of the current programmed by the CLPROG pin. A 2 μ A pull-down current is internally connected to this pin to ensure it is low at power up when the pin is not being driven externally.

SUSP (Pin 16): Suspend Mode Input. Pulling this pin above 1.2V will disable the power path from IN to OUT. The supply current from IN will be reduced to comply with the USB specification for suspend mode. Both the ability to charge the battery from HVIN and the ideal diode function (from BAT to OUT) will remain active. Suspend mode will reset the charge timer if OUT is less than BAT while in suspend mode. If OUT is kept greater than BAT, such as when the high voltage input is present, the charge timer will not be reset when the part is put in suspend. A 2 μ A pull-down current is internally connected to this pin to ensure it is low at power up when the pin is not being driven externally.

TIMER (Pin 17): Timer Capacitor. Placing a capacitor, C_{TIMER} , to GND sets the timer period. The timer period is:

$$t_{TIMER}(\text{hours}) = \frac{C_{TIMER} \cdot R_{PROG} \cdot 3\text{hours}}{0.1\mu\text{F} \cdot 100k}$$

Charge time is increased if charge current is reduced due to load current, thermal regulation and current limit selection (HPWR low).

Shorting the TIMER pin to GND disables the battery charging functions.

HVOUT (Pin 18): Voltage Output of the High Voltage Regulator. When sufficient voltage is present at HVOUT, the low voltage power path from IN to OUT will be disconnected and the \overline{HVPR} pin will be pulled low to indicate that a high voltage wall adapter has been detected. The LTC4090 high voltage regulator will maintain just enough differential voltage between HVOUT and BAT to keep the battery charger MOSFET out of dropout (typically 300mV from OUT to BAT). The LTC4090-5 high voltage regulator will provide a 5V output to the battery charger MOSFET. HVOUT should be bypassed with at least 22 μ F to GND.

BOOST (Pin 19): This pin is used to provide drive voltage, higher than the input voltage, to the internal bipolar NPN power switch.

SW (Pin 20): The SW pin is the output of the internal high voltage power switch. Connect this pin to the inductor, catch diode and boost capacitor.

HVIN (Pin 21): High Voltage Regulator Input. The HVIN pin supplies current to the internal high voltage regulation and to the internal high voltage power switch. The presence of a high voltage input takes priority over the USB V_{BUS} input (i.e., when a high voltage input supply is detected, the USB IN to OUT path is disconnected). This pin must be locally bypassed.

HVEN (Pin 22): High Voltage Regulator Enable Input. The HVEN pin is used to disable the high voltage input path. Tie to ground to disable the high voltage input or tie to at least 2.3V to enable the high voltage path. If this feature is not used, tie HVEN to the HVIN pin. This pin can also be used to soft-start the high voltage regulator; see the Applications Information section for more information.

Exposed Pad (Pin 23): Ground. The exposed package pad is ground and must be soldered to the PC board for proper functionality and for maximum heat transfer (use several vias directly under the LTC4090/LTC4090-5).

BLOCK DIAGRAM

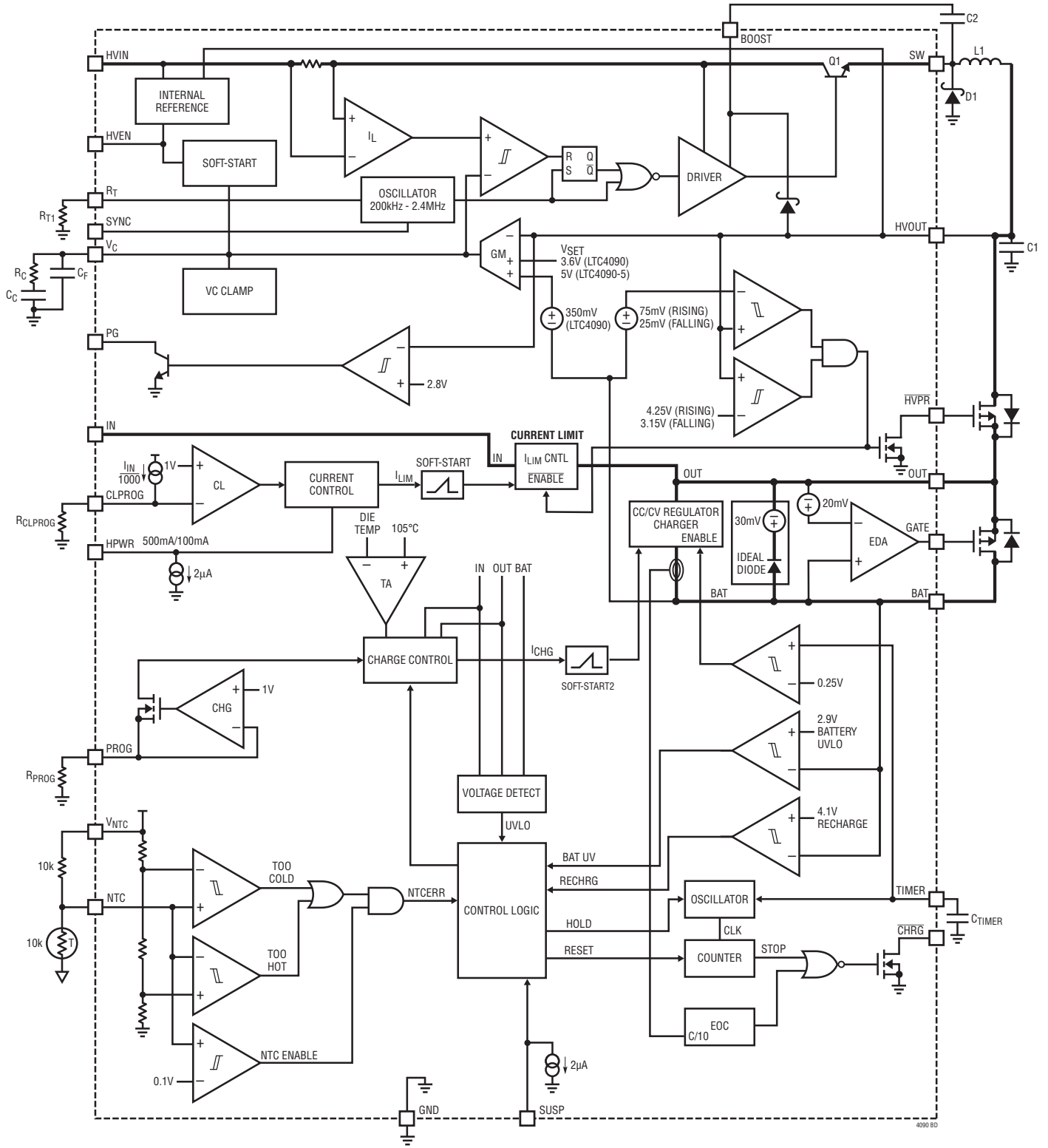

OPERATION

USB Input Current Limit

The input current limit and charge control circuits of the LTC4090/LTC4090-5 are designed to limit input current as well as control battery charge current as a function of I_{OUT}. OUT drives the external load and the battery charger.

If the combined load at OUT does not exceed the programmed input current limit, OUT will be connected to IN through an internal 215mΩ P-channel MOSFET.

If the combined load at OUT exceeds the programmed input current limit, the battery charger will reduce its charge current by the amount necessary to enable the external load to be satisfied while maintaining the programmed input current. Even if the battery charge current is set to exceed the allowable USB current, a correctly programmed input current limit will ensure that the USB specification is never violated. Furthermore, load current at OUT will always be prioritized and only excess available current will be used to charge the battery.

The input current limit, I_{CL}, can be programmed using the following formula:

$$I_{CL} = \left(\frac{1000}{R_{CLPROG}} \cdot V_{CLPROG} \right) = \frac{1000V}{R_{CLPROG}}$$

where V_{CLPROG} is the CLPROG pin voltage (typically 1V) and R_{CLPROG} is the total resistance from the CLPROG pin to ground. For best stability over temperature and time, 1% metal film resistors are recommended.

The programmed battery charge current, I_{CHG}, is defined as:

$$I_{CHG} = \left(\frac{50,000}{R_{PROG}} \cdot V_{PROG} \right) = \frac{50,000V}{R_{PROG}}$$

Input current, I_{IN}, is equal to the sum of the BAT pin output current and the OUT pin output current. V_{CLPROG} will track the input current according to the following equation:

$$I_{IN} = I_{OUT} + I_{BAT} = \frac{V_{CLPROG}}{R_{CLPROG}} \cdot 1000$$

In USB applications, the maximum value for R_{CLPROG} should be 2.1k. This will prevent the input current from exceeding

500mA due to LTC4090/LTC4090-5 tolerances and quiescent currents. A 2.1k CLPROG resistor will give a typical current limit of 476mA in high power mode (when HPWR is high) or 95mA in low power mode (when HPWR is low).

When SUSP is driven to a logic high, the input power path is disabled and the ideal diode from BAT to OUT will supply power to the application.

High Voltage Step Down Regulator

The power delivered from HVIN to HVOUT is controlled by a constant-frequency, current mode step down regulator. An external P-channel MOSFET directs this power to OUT and prevents reverse conduction from OUT to HVOUT (and ultimately HVIN).

An oscillator, with frequency set by R_T, enables an RS flip-flop, turning on the internal power switch. An amplifier and comparator monitor the current flowing between HVIN and SW pins, turning the switch off when this current reaches a level determined by the voltage at V_C. An error amplifier servos the V_C node to maintain approximately 300mV between OUT and BAT (LTC4090). By keeping the voltage across the battery charger low, efficiency is optimized because power lost to the battery charger is minimized and power available to the external load is maximized. If the BAT pin voltage is less than approximately 3.3V, then the error amplifier will servo the V_C node to provide a constant HVOUT output voltage of about 3.6V (LTC4090). An active clamp on the V_C node provides current limit. The V_C node is also clamped to the voltage on the HVEN pin; soft-start is implemented by generating a voltage ramp at the HVEN pin using an external resistor and capacitor.

The switch driver operates from either the high voltage input or from the BOOST pin. An external capacitor and internal diode are used to generate a voltage at the BOOST pin that is higher than the input supply. This allows the driver to fully saturate the internal bipolar NPN power switch for efficient operation.

To further optimize efficiency, the high voltage buck regulator automatically switches to Burst Mode[®] operation in light load situations. Between bursts, all circuitry associated with controlling the output switch is shut down reducing the input supply current.

OPERATION

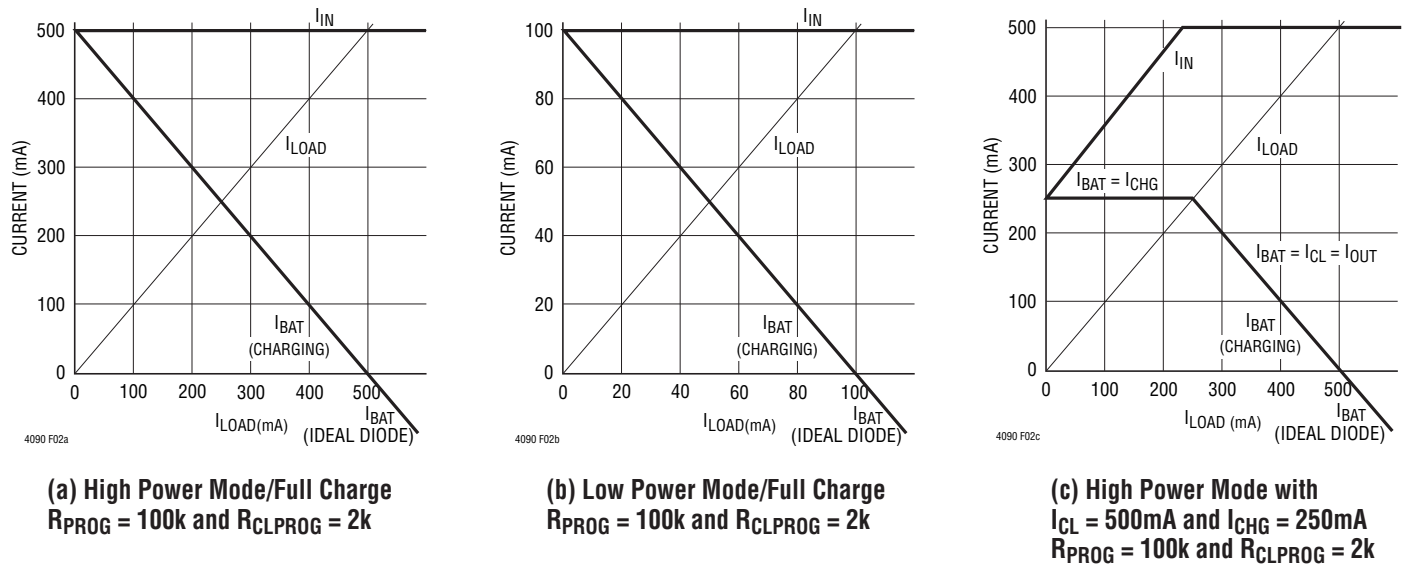

Figure 2. Input and Battery Currents as a Function of Load Current

The oscillator reduces the switch regulator’s operating frequency when the voltage at the HVOUT pin is low (below 2.95V). This frequency foldback helps to control the output current during start-up and overload.

The high voltage regulator contains a power good comparator which trips when the HVOUT pin is at 2.8V. The PG output is an open-collector transistor that is off when the output is in regulation, allowing an external resistor to pull the PG pin high. Power good is valid when the switching regulator is enabled and HVIN is above 3.6V.

Ideal Diode From BAT to OUT

The LTC4090/LTC4090-5 have an internal ideal diode as well as a controller for an optional external ideal diode. If a battery is the only power supply available, or if the load current exceeds the programmed input current limit, then the battery will automatically deliver power to the load via an ideal diode circuit between the BAT and OUT pins. The ideal diode circuit (along with the recommended 4.7 μ F capacitor on the OUT pin) allows the LTC4090/LTC4090-5 to handle large transient loads and wall adapter or USB V_{BUS} connect/disconnect scenarios without the need for large bulk capacitors. The ideal diode responds within a few microseconds and prevents the OUT pin voltage from dropping significantly below the BAT pin voltage.

A comparison of the I-V curve of the ideal diode and a Schottky diode can be seen in Figure 3.

If the desired input current increases beyond the programmed input current limit additional current will be drawn from the battery via the internal ideal diode. Furthermore, if power to IN (USB V_{BUS}) or HVIN (high voltage input) is removed, then all of the application power will be provided by the battery via the ideal diode. A 4.7 μ F capacitor at OUT is sufficient to keep a transition from input power to battery power from causing significant output voltage droop. The ideal diode consists of a precision amplifier that enables a large P-channel MOSFET transistor whenever the voltage at OUT is approximately 20mV (V_{FWD}) below the voltage at BAT. The resistance of the internal ideal diode is approximately 215m Ω .

If this is sufficient for the application then no external components are necessary. However if more conductance is needed, an external P-channel MOSFET can be added from BAT to OUT. The GATE pin of the LTC4090/LTC4090-5 drives the gate of the external PFET for automatic ideal diode control. The source of the external MOSFET should be connected to OUT and the drain should be connected to BAT. In order to help protect the external MOSFET in overcurrent situations, it should be placed in close thermal contact to the LTC4090/LTC4090-5.

OPERATION

Suspend Mode

When SUSP is pulled above V_{IH} the LTC4090/LTC4090-5 enter suspend mode to comply with the USB specification. In this mode, the power path between IN and OUT is put in a high impedance state to reduce the IN input current to $50\mu\text{A}$. If no other power source is available to drive HVIN, the system load connected to OUT is supplied through the ideal diodes connected to BAT.

Battery Charger

The battery charger circuits of the LTC4090/LTC4090-5 are designed for charging single-cell lithium-ion batteries. Featuring an internal P-channel power MOSFET, the charger uses a constant-current/constant-voltage charge algorithm with programmable charge current and a programmable timer for charge termination. Charge current can be programmed up to 1.5A. The final float voltage accuracy is $\pm 0.8\%$ typical. No blocking diode or sense resistor is required when powering either the IN or the HVIN pins. The $\overline{\text{CHRG}}$ open-drain status output provides information regarding the charging status of the LTC4090/LTC4090-5 at all times. An NTC input provides the option of charge qualification using battery temperature.

The charge cycle begins when the voltage at the OUT pin rises above the battery voltage and the battery voltage is below the recharge threshold. No charge current actually flows until the OUT voltage is 100mV above the BAT voltage. At the beginning of the charge cycle, if the battery voltage is below 2.9V, the charger goes into trickle charge mode

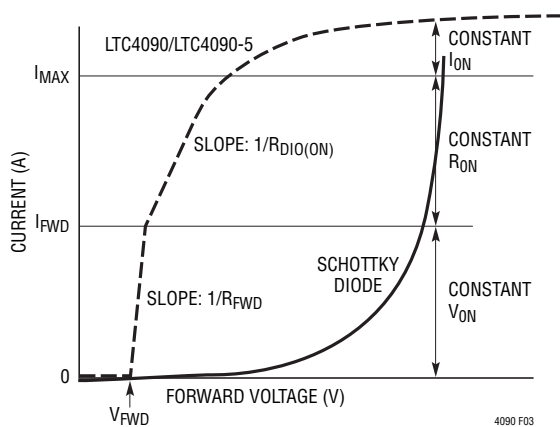

Figure 3. LTC4090/LTC4090-5 vs Schottky Diode Forward Voltage Drop

to bring the cell voltage up to a safe level for charging. The charger goes into the fast charge constant-current mode once the voltage on the BAT pin rises above 2.9V. In constant-current mode, the charge current is set by R_{PROG} . When the battery approaches the final float voltage, the charge current begins to decrease as the LTC4090/LTC4090-5 switch to constant-voltage mode. When the charge current drops below 10% of the programmed value while in constant-voltage mode the $\overline{\text{CHRG}}$ pin assumes a high impedance state.

An external capacitor on the TIMER pin sets the total minimum charge time. When this time elapses, the charge cycle terminates and the $\overline{\text{CHRG}}$ pin assumes a high impedance state, if it has not already done so. While charging in constant-current mode, if the charge current is decreased by thermal regulation or in order to maintain the programmed input current limit, the charge time is automatically increased. In other words, the charge time is extended inversely proportional to the actual charge current delivered to the battery. For Li-Ion and similar batteries that require accurate final float potential, the internal bandgap reference, voltage amplifier and the resistor divider provide regulation with $\pm 0.8\%$ accuracy.

Trickle Charge and Defective Battery Detection

At the beginning of a charge cycle, if the battery voltage is below 2.9V, the charger goes into trickle charge reducing the charge current to 10% of the full-scale current. If the low battery voltage persists for one quarter of the programmed total charge time, the battery is assumed to be defective, the charge cycle is terminated and the $\overline{\text{CHRG}}$ pin output assumes a high impedance state. If for any reason the battery voltage rises above $\sim 2.9\text{V}$ the charge cycle will be restarted. To restart the charge cycle (i.e., when the dead battery is replaced with a discharged battery), simply remove the input voltage and reapply it or cycle the TIMER pin to 0V.

Programming Charge Current

The formula for the battery charge current is:

$$I_{\text{CHG}} = I_{\text{PROG}} \cdot 50,000 = \frac{V_{\text{PROG}}}{R_{\text{PROG}}} \cdot 50,000$$

OPERATION

where V_{PROG} is the PROG pin voltage and R_{PROG} is the total resistance from the PROG pin to ground. Keep in mind that when the LTC4090/LTC4090-5 are powered from the IN pin, the programmed input current limit takes precedence over the charge current. In such a scenario, the charge current cannot exceed the programmed input current limit.

For example, if typical 500mA charge current is required, calculate:

$$R_{\text{PROG}} = \frac{1\text{V}}{500\text{mA}} \cdot 50,000 = 100\text{k}$$

For best stability over temperature and time, 1% metal film resistors are recommended. Under trickle charge conditions, this current is reduced to 10% of the full-scale value.

The Charge Timer

The programmable charge timer is used to terminate the charge cycle. The timer duration is programmed by an external capacitor at the TIMER pin. The charge time is typically:

$$t_{\text{TIMER}}(\text{hours}) = \frac{C_{\text{TIMER}} \cdot R_{\text{PROG}} \cdot 3\text{hours}}{0.1\mu\text{F} \cdot 100\text{k}}$$

The timer starts when an input voltage greater than the undervoltage lockout threshold level is applied or when leaving shutdown and the voltage on the battery is less than the recharge threshold. At power-up or exiting shutdown with the battery voltage less than the recharge threshold, the charge time is a full cycle. If the battery is greater than the recharge threshold the timer will not start and charging is prevented. If after power-up the battery voltage drops below the recharge threshold, or if after a charge cycle the battery voltage is still below the recharge threshold, the charge time is set to one-half of a full cycle.

The LTC4090/LTC4090-5 have a feature that extends charge time automatically. Charge time is extended if the charge current in constant-current mode is reduced due to load current or thermal regulation. This change in charge time is inversely proportional to the change in charge current.

As the LTC4090/LTC4090-5 approach constant-voltage mode the charge current begins to drop. This change in charge current is due to normal charging operation and does not affect the timer duration.

Consider, for example, a USB charge condition where $R_{\text{CLPROG}} = 2\text{k}$, $R_{\text{PROG}} = 100\text{k}$ and $C_{\text{TIMER}} = 0.1\mu\text{F}$. This corresponds to a three hour charge cycle. However, if the HPWR input is set to a logic low, then the input current limit will be reduced from 500mA to 100mA. With no additional system load, this means the charge current will be reduced to 100mA. Therefore, the termination timer will automatically slow down by a factor of five until the charger reaches constant-voltage mode (i.e., V_{BAT} approaches 4.2V) or HPWR is returned to a logic high. The charge cycle is automatically lengthened to account for the reduced charge current. The exact time of the charge cycle will depend on how long the charger remains in constant-current mode and/or how long the HPWR pin remains logic low.

Once a timeout occurs and the voltage on the battery is greater than the recharge threshold, the charge current stops, and the $\overline{\text{CHRG}}$ output assumes a high impedance state if it has not already done so.

Connecting the TIMER pin to ground disables the battery charger.

$\overline{\text{CHRG}}$ Status Output Pin

When the charge cycle starts, the $\overline{\text{CHRG}}$ pin is pulled to ground by an internal N-channel MOSFET capable of driving an LED. When the charge current drops below 10% of the programmed full charge current while in constant-voltage mode, the pin assumes a high impedance state, but charge current continues to flow until the charge time elapses. If this state is not reached before the end of the programmable charge time, the pin will assume a high impedance state when a timeout occurs. The $\overline{\text{CHRG}}$ current detection threshold can be calculated by the following equation:

$$I_{\text{DETECT}} = \frac{0.1\text{V}}{R_{\text{PROG}}} \cdot 50,000 = \frac{5000\text{V}}{R_{\text{PROG}}}$$

OPERATION

For example, if the full charge current is programmed to 500mA with a 100k PROG resistor the $\overline{\text{CHRG}}$ pin will change state at a battery charge current of 50mA.

Note: The end-of-charge (EOC) comparator that monitors the charge current latches its decision. Therefore, the first time the charge current drops below 10% of the programmed full charge current while in constant-voltage mode, it will toggle $\overline{\text{CHRG}}$ to a high impedance state. If, for some reason the charge current rises back above the threshold, the $\overline{\text{CHRG}}$ pin will not resume the strong pull-down state. The EOC latch can be reset by a recharge cycle (i.e., V_{BAT} drops below the recharge threshold) or toggling the input power to the part.

Automatic Recharge

After the battery charger terminates, it will remain off drawing only microamperes of current from the battery. If the product remains in this state long enough, the battery will eventually self discharge. To ensure that the battery is always topped off, a charge cycle will automatically begin when the battery voltage falls below V_{RECHRG} (typically 4.1V). To prevent brief excursions below V_{RECHRG} from resetting the safety timer, the battery voltage must be below V_{RECHRG} for more than a few milliseconds. The charge cycle and safety timer will also restart if the IN UVLO cycles low and then high (e.g., IN is removed and then replaced).

Thermal Regulation

To prevent thermal damage to the IC or surrounding components, an internal thermal feedback loop will automatically decrease the programmed charge current if the die temperature rises to approximately 105°C. Thermal regulation protects the LTC4090/LTC4090-5 from excessive temperature due to high power operation or high ambient thermal conditions and allows the user to push the limits of the power handling capability with a given circuit board design without risk of damaging the LTC4090/LTC4090-5 or external components. The benefit

of the LTC4090/LTC4090-5 thermal regulation loop is that charge current can be set according to actual conditions rather than worst-case conditions with the assurance that the battery charger will automatically reduce the current in worst-case conditions.

Undervoltage Lockout

An internal undervoltage lockout circuit monitors the input voltage (IN) and the output voltage (OUT) and disables either the input current limit or the battery charger circuits or both. The input current limit circuitry is disabled until V_{IN} rises above the undervoltage lockout threshold and V_{IN} exceeds V_{OUT} by 50mV. The battery charger circuits are disabled until V_{OUT} exceeds V_{BAT} by 50mV. Both undervoltage lockout comparators have built-in hysteresis.

NTC Thermistor

The battery temperature is measured by placing a negative temperature coefficient (NTC) thermistor close to the battery pack. To use this feature connect the NTC thermistor, R_{NTC} , between the NTC pin and ground and a bias resistor, R_{NOM} , from VNTC to NTC. R_{NOM} should be a 1% resistor with a value equal to the value of the chosen NTC thermistor at 25°C (denoted $R_{25\text{C}}$).

The LTC4090/LTC4090-5 will pause charging when the resistance of the NTC thermistor drops to 0.41 times the value of $R_{25\text{C}}$ or approximately 4.1k (for a Vishay curve 2 thermistor, this corresponds to approximately 50°C). The safety timer also pauses until the thermistor indicates a return to a valid temperature. As the temperature drops, the resistance of the NTC thermistor rises. The LTC4090/LTC4090-5 are also designed to pause charging (and timer) when the value of the NTC thermistor increases to 2.82 times the value of $R_{25\text{C}}$. For a Vishay curve 2 thermistor this resistance, 28.2k, corresponds to approximately 0°C. The hot and cold comparators each have approximately 3°C of hysteresis to prevent oscillation about the trip point. Grounding the NTC pin disables all NTC functionality.

APPLICATIONS INFORMATION

USB and 5V Wall Adapter Power

Although the LTC4090/LTC4090-5 are designed to draw power from a USB port, a higher power 5V wall adapter can also be used to power the application and charge the battery (higher voltage wall adapters can be connected directly to HVIN). Figure 4 shows an example of combining a 5V wall adapter and a USB power input. With its gate grounded by 1k, P-channel MOSFET MP1 provides USB power to the LTC4090/LTC4090-5 when 5V wall power is not available. When 5V wall power is available, diode D1 supplies power to the LTC4090/LTC4090-5, pulls the gate of MN1 high to increase the charge current (by increasing the input current limit), and pulls the gate of MP1 high to disable it and prevent conduction back to the USB port.

Setting the Switching Frequency

The high voltage switching regulator uses a constant-frequency PWM architecture that can be programmed to switch from 200kHz to 2.4MHz by using a resistor tied from the R_T pin to ground. A table showing the necessary R_T value for a desired switching frequency is in Table 1.

Table 1. Switching Frequency vs R_T Value

SWITCHING FREQUENCY (MHz)	R _T VALUE (kΩ)
0.2	187
0.3	121
0.4	88.7
0.5	68.1
0.6	56.2
0.7	46.4
0.8	40.2
0.9	34.0
1.0	29.4
1.2	23.7
1.4	19.1
1.6	16.2
1.8	13.3
2.0	11.5
2.2	9.76
2.4	8.66

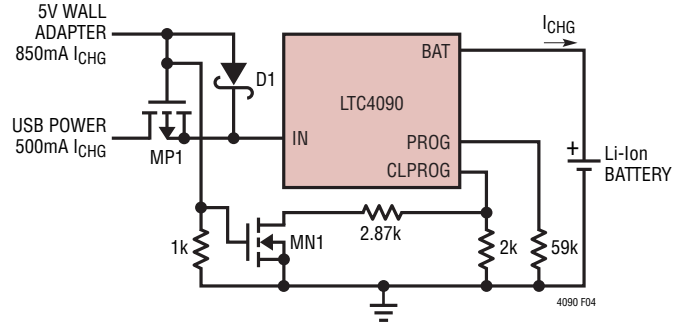

Figure 4. USB or 5V Wall Adapter Power

Operating Frequency Trade-Offs

Selection of the operating frequency for the high voltage buck regulator is a trade-off between efficiency, component size, minimum dropout voltage, and maximum input voltage. The advantage of high frequency operation is that smaller inductor and capacitor values may be used. The disadvantages are lower efficiency, lower maximum input voltage, and higher dropout voltage. The highest acceptable switching frequency ($f_{SW(MAX)}$) for a given application can be calculated as follows:

$$f_{SW(MAX)} = \frac{V_D + V_{HVOUT}}{t_{ON(MIN)} \cdot (V_D + V_{HVIN} - V_{SW})}$$

where V_{HVIN} is the typical high voltage input voltage, V_{HVOUT} is the output voltage of the switching regulator, V_D is the catch diode drop (~0.5V), and V_{SW} is the internal switch drop (~0.5V at max load). This equation shows that slower switching frequency is necessary to safely accommodate high V_{HVIN}/V_{HVOUT} ratio. Also, as shown in the next section, lower frequency allows a lower dropout voltage. The reason input voltage range depends on the switching frequency is because the high voltage switch has finite minimum on and off times. The switch can turn on for a minimum of ~150ns and turn off for a minimum of ~150ns. This means that the minimum and maximum duty cycles are:

$$DC_{MIN} = f_{SW} \cdot t_{ON(MIN)}$$

$$DC_{MAX} = 1 - f_{SW} \cdot t_{OFF(MIN)}$$

where f_{SW} is the switching frequency, $t_{ON(MIN)}$ is the minimum switch-on time (~150ns), and $t_{OFF(MIN)}$ is the

APPLICATIONS INFORMATION

minimum switch-off time (~150ns). These equations show that duty cycle range increases when switching frequency is decreased.

A good choice of switching frequency should allow adequate input voltage range (see next section) and keep the inductor and capacitor values small.

HVIN Input Voltage Range

The maximum input voltage range for the LTC4090/LTC4090-5 applications depends on the switching frequency, the Absolute Maximum Ratings of the V_{HVIN} and BOOST pins, and the operating mode.

The high voltage switching regulator can operate from input voltages up to 36V, and safely withstand input voltages up to 60V. Note that while $V_{HVIN} > 38V$ (typical), the LTC4090/LTC4090-5 will stop switching, allowing the output to fall out of regulation.

While the high voltage regulator output is in start-up, short-circuit, or other overload conditions, the switching frequency should be chosen according to the following discussion.

For safe operation at inputs up to 60V the switching frequency must be low enough to satisfy $V_{HVIN(MAX)} \geq 40V$ according to the following equation. If lower $V_{HVIN(MAX)}$ is desired, this equation can be used directly.

$$V_{HVIN(MAX)} = \frac{V_{HVOUT} + V_D}{f_{SW} \cdot t_{ON(MIN)}} - V_D + V_{SW}$$

where $V_{HVIN(MAX)}$ is the maximum operating input voltage, V_{HVOUT} is the high voltage regulator output voltage, V_D is the catch diode drop (~0.5V), V_{SW} is the internal switch drop (~0.5V at max load), f_{SW} is the switching frequency (set by R_T), and $t_{ON(MIN)}$ is the minimum switch-on time (~150ns). Note that a higher switching frequency will depress the maximum operating input voltage. Conversely, a lower switching frequency will be necessary to achieve safe operation at high input voltages.

If the output is in regulation and no short-circuit, start-up, or overload events are expected, then input voltage transients of up to 60V are acceptable regardless of the switching frequency. In this mode, the LTC4090/LTC4090-5 may

enter pulse-skipping operation where some switching pulses are skipped to maintain output regulation. In this mode the output voltage ripple and inductor current ripple will be higher than in normal operation. Above 38V, switching will stop.

The minimum input voltage is determined by either the high voltage regulator's minimum operating voltage of ~6V or by its maximum duty cycle (see equation in previous section). The minimum input voltage due to duty cycle is:

$$V_{HVIN(MIN)} = \frac{V_{HVOUT} + V_D}{1 - f_{SW} t_{OFF(MIN)}} - V_D + V_{SW}$$

where $V_{HVIN(MIN)}$ is the minimum input voltage, and $t_{OFF(MIN)}$ is the minimum switch-off time (150ns). Note that higher switching frequency will increase the minimum input voltage. If a lower dropout voltage is desired, a lower switching frequency should be used.

Inductor Selection and Maximum Output Current

A good choice for the inductor value is $L = 6.8\mu H$ (assuming a 800kHz operating frequency). With this value the maximum load current will be ~2.4A. The RMS current rating of the inductor must be greater than the maximum load current and its saturation current should be about 30% higher. Note that the maximum load current will be programmed charge current plus the largest expected application load current. For robust operation in fault conditions, the saturation current should be ~3.5A. To keep efficiency high, the series resistance (DCR) should be less than 0.1Ω. Table 2 lists several vendors and types that are suitable.

Table 2. Inductor Vendors

VENDOR	URL	PART SERIES	TYPE
Murata	www.murata.com	LQH55D	Open
TDK	www.componenttdk.com	SLF7045 SLF10145	Shielded Shielded
Toko	www.toko.com	D62CB D63CB D75C D75F	Shielded Shielded Shielded Open
Sumida	www.sumida.com	CR54 CDRH74 CDRH6D38 CR75	Open Shielded Shielded Open

APPLICATIONS INFORMATION

Catch Diode

The catch diode conducts current only during switch-off time. Average forward current in normal operation can be calculated from:

$$I_{D(AVG)} = I_{HVOUT} \cdot \frac{(V_{HVIN} - V_{HVOUT})}{V_{HVIN}}$$

where I_{HVOUT} is the output load current. The only reason to consider a diode with a larger current rating than necessary for nominal operation is for the worst-case condition of shorted output. The diode current will then increase to the typical peak switch current. Peak reverse voltage is equal to the regulator input voltage. Use a Schottky diode with a reverse voltage rating greater than the input voltage. The overvoltage protection feature in the high voltage regulator will keep the switch off when $V_{HVIN} > 40V$ which allows the use of 40V rated Schottky even when V_{HVIN} ranges up to 60V. Table 3 lists several Schottky diodes and their manufacturers.

Table 3. Diode Vendors

PART NUMBER	V _R (V)	I _A AVE (A)	V _F AT 1A (MV)	V _F AT 2A (MV)
On Semiconductor MBRM120E MBRM140	20 40	1 1	530 550	595
Diodes Inc. B120 B130 B220 B230 DFLS240L	20 30 20 30 40	1 1 2 2 2	500 500	500 500 500
International Rectifier 10BQ030 20BQ030	30 30	1 2	420	470 470

High Voltage Regulator Output Capacitor Selection

The high voltage regulator output capacitor has two essential functions. Along with the inductor, it filters the square wave generated at the switch pin to produce the DC output. In this role it determines the output ripple, and low impedance at the switching frequency is important. The second function is to store energy in order to satisfy transient loads and stabilize the LTC4090/LTC4090-5's control loop. Ceramic capacitors have very low equivalent

series resistance (ESR) and provide the best ripple performance. A good starting value is:

$$C_{OUT} = \frac{100}{V_{OUT} f_{SW}}$$

where f_{SW} is in MHz, and C_{OUT} is the recommended output capacitance in μF . Use X5R or X7R types. This choice will provide low output ripple and good transient response. Transient performance can be improved with a higher value capacitor if the compensation network is also adjusted to maintain the loop bandwidth. A lower value of output capacitor can be used to save space and cost but transient performance will suffer. See the High Voltage Regulator Frequency Compensation section to choose an appropriate compensation network.

When choosing a capacitor, look carefully through the data sheet to find out what the actual capacitance is under operating conditions (applied voltage and temperature). A physically larger capacitor, or one with a higher voltage rating, may be required. High performance tantalum or electrolytic capacitors can be used for the output capacitor. Low ESR is important, so choose one that is intended for use in switching regulators. The ESR should be specified by the supplier, and should be 0.05Ω or less. Such a capacitor will be larger than a ceramic capacitor and will have a larger capacitance, because the capacitor must be large to achieve low ESR.

Ceramic Capacitors

Ceramic capacitors are small, robust and have very low ESR. However, ceramic capacitors can cause problems when used with the high voltage switching regulator due to their piezoelectric nature. When in Burst Mode operation, the LTC4090/LTC4090-5's switching frequency depends on the load current, and at very light loads the LTC4090/LTC4090-5 can excite the ceramic capacitor at audio frequencies, generating audible noise. Since the LTC4090/LTC4090-5 operate at a lower current limit during Burst Mode operation, the noise is typically very quiet to a casual ear. If this is unacceptable, use a high performance tantalum or electrolytic capacitor at the output.

APPLICATIONS INFORMATION

High Voltage Regulator Frequency Compensation

The LTC4090/LTC4090-5 high voltage regulator uses current mode control to regulate the output. This simplifies loop compensation. In particular, the high voltage regulator does not require the ESR of the output capacitor for stability, so you are free to use ceramic capacitors to achieve low output ripple and small circuit size. Frequency compensation is provided by the components tied to the V_C pin, as shown in Figure 1. Generally a capacitor (C_C) and a resistor (R_C) in series to ground are used. In addition, there may be a lower value capacitor in parallel. This capacitor (C_F) is not part of the loop compensation but is used to filter noise at the switching frequency, and is required only if a phase-lead capacitor is used or if the output capacitor has high ESR.

Loop compensation determines the stability and transient performance. Designing the compensation network is a bit complicated and the best values depend on the application and in particular the type of output capacitor. A practical approach is to start with the front page schematic and tune the compensation network to optimize performance. Stability should then be checked across all operating conditions, including load current, input voltage and temperature. The LTC1375 data sheet contains a more thorough discussion of loop compensation and describes how to test the stability using a transient load. Figure 5 shows the transient response when the load current is stepped from 500mA to 1500mA and back to 500mA.

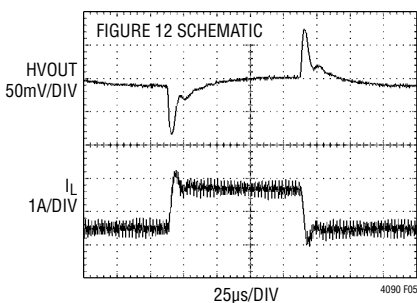

Figure 5. Transient Load Response of the LTC4090 High Voltage Regulator Front Page Application as the Load Current is Stepped from 500mA to 1500mA.

Low Ripple Burst Mode Operation and Pulse-Skipping Mode

The LTC4090/LTC4090-5 are capable of operating in either low ripple Burst Mode operation or pulse-skipping mode which are selected using the SYNC pin. Tie the SYNC pin below $V_{SYNC,L}$ (typically 0.5V) for low ripple Burst Mode operation or above $V_{SYNC,H}$ (typically 0.8V) for pulse-skipping mode.

To enhance efficiency at light loads, the LTC4090/LTC4090-5 can be operated in low ripple Burst Mode operation which keeps the output capacitor charged to the proper voltage while minimizing the input quiescent current. During Burst Mode operation, the LTC4090/LTC4090-5 deliver single cycle bursts of current to the output capacitor followed by sleep periods where the output power is delivered to the load by the output capacitor. Because the LTC4090/LTC4090-5 deliver power to output with single, low current pulses, the output ripple is kept below 15mV for a typical application. As the load current decreases towards a no load condition, the percentage of time that the high voltage regulator operates in sleep mode increases and the average input current is greatly reduced resulting in high efficiency even at very low loads. See Figure 6.

At higher output loads (above 70mA for the front page application) the LTC4090/LTC4090-5 will be running at the frequency programmed by the R_T resistor, and will be operating in standard PWM mode. The transition between PWM and low ripple Burst Mode operation is seamless, and will not disturb the output voltage.

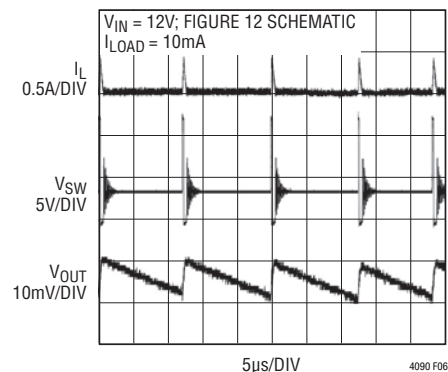

Figure 6. High Voltage Regulator Burst Mode Operation

APPLICATIONS INFORMATION

If low quiescent current is not required, the LTC4090/LTC4090-5 can operate in pulse-skipping mode. The benefit of this mode is that the LTC4090/LTC4090-5 will enter full frequency standard PWM operation at a lower output load current than when in Burst Mode operation. The front page application circuit will switch at full frequency at output loads higher than about 60mA.

Boost Pin Considerations

Capacitor C2 (see Block Diagram) and an internal diode are used to generate a boost voltage that is higher than the input voltage. In most cases, a 0.47 μ F capacitor will work well. The BOOST pin must be at least 2.3V above the SW pin for proper operation.

High Voltage Regulator Soft-Start

The HVEN pin can be used to soft-start the high voltage regulator of the LTC4090/LTC4090-5, reducing maximum input current during start-up. The HVEN pin is driven through an external RC filter to create a voltage ramp at this pin. Figure 7 shows the start-up and shutdown waveforms with the soft-start circuit. By choosing a large RC time constant, the peak start-up current can be reduced to the current that is required to regulate the output, with no overshoot. Choose the value of the resistor so that it can supply 20 μ A when the HVEN pin reaches 2.3V.

Synchronization and Mode

The SYNC pin allows the high voltage regulator to be synchronized to an external clock.

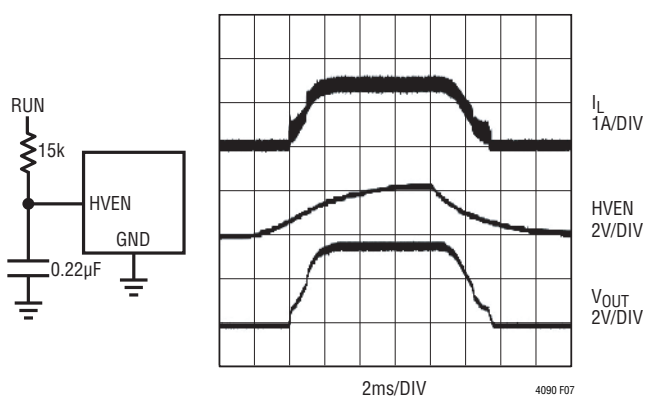

Figure 7. To Soft-Start the High Voltage Regulator, Add a Resistor and Capacitor to the HVEN Pin

Synchronizing the LTC4090/LTC4090-5 internal oscillator to an external frequency can be done by connecting a square wave (with 20% to 80% duty cycle) to the SYNC pin. The square wave amplitude should be such that the valleys are below 0.3V and the peaks are above 0.8V (up to 6V). The high voltage regulator may be synchronized over a 300kHz to 2MHz range. The R_T resistor should be chosen such that the LTC4090/LTC4090-5 oscillate 25% lower than the external synchronization frequency to ensure adequate slope compensation. While synchronized, the high voltage regulator will turn on the power switch on positive going edges of the clock. When the power good (PG) output is low, such as during start-up, short-circuit, and overload conditions, the LTC4090/LTC4090-5 will disable the synchronization feature. The SYNC pin should be grounded when synchronization is not required.

Alternate NTC Thermistors and Biasing

The LTC4090/LTC4090-5 provide temperature qualified charging if a grounded thermistor and a bias resistor are connected to NTC (see Figure 8). By using a bias resistor whose value is equal to the room temperature resistance of the thermistor (R_{25C}) the upper and lower temperatures are preprogrammed to approximately 50°C and 0°C, respectively (assuming a Vishay curve 2 thermistor).

The upper and lower temperature thresholds can be adjusted by either a modification of the bias resistor value or by adding a second adjustment resistor to the circuit. If only the bias resistor is adjusted, then either the upper or the lower threshold can be modified but not both. The other trip point will be determined by the characteristics of the thermistor. Using the bias resistor in addition to an adjustment resistor, both the upper and the lower temperature trip points can be independently programmed with the constraint that the difference between the upper and lower temperature thresholds cannot decrease. Examples of each technique are given below.

NTC thermistors have temperature characteristics which are indicated on resistance-temperature conversion tables. The Vishay-Dale thermistor NTHS0603N02N1002J, used in the following examples, has a nominal value of 10k and follows the Vishay curve 2 resistance-temperature characteristic. The LTC4090/LTC4090-5's trip points are designed

APPLICATIONS INFORMATION

to work with thermistors whose resistance-temperature characteristics follow Vishay Dale's R-T curve 2. The Vishay NTHS0603N02N1002J is an example of such a thermistor. However, Vishay Dale has many thermistor products that follow the R-T curve 2 characteristic in a variety of sizes. Furthermore, any thermistor whose ratio of r_{COLD} to r_{HOT} is about 7.0 will also work (Vishay Dale R-T curve 2 shows a ratio of $2.815/0.409 = 6.89$).

In the explanation below, the following notation is used.

R_{25C} = Value of the Thermistor at 25°C

$R_{NTC|COLD}$ = Value of Thermistor at the Cold Trip Point

$R_{NTC|HOT}$ = Value of the Thermistor at the Hot Trip Point

r_{COLD} = Ratio of $R_{NTC|COLD}$ to R_{25C}

r_{HOT} = Ratio of $R_{NTC|HOT}$ to R_{25C}

R_{NOM} = Primary Thermistor Bias Resistor (see Figure 8)

R_1 = Optional Temperature Range Adjustment resistor (see Figure 9)

The trip points for the LTC4090/LTC4090-5's temperature qualification are internally programmed at $0.29 \cdot V_{NTC}$ for the hot threshold and $0.74 \cdot V_{NTC}$ for the cold threshold.

Therefore, the hot trip point is set when:

$$\frac{R_{NTC|HOT}}{R_{NOM} + R_{NTC|HOT}} \cdot V_{NTC} = 0.29 \cdot V_{NTC}$$

and the cold trip point is set when:

$$\frac{R_{NTC|COLD}}{R_{NOM} + R_{NTC|COLD}} \cdot V_{NTC} = 0.74 \cdot V_{NTC}$$

Solving these equations for $R_{NTC|COLD}$ and $R_{NTC|HOT}$ results in the following:

$$R_{NTC|HOT} = 0.409 \cdot R_{NOM}$$

and

$$R_{NTC|COLD} = 2.815 \cdot R_{NOM}$$

By setting R_{NOM} equal to R_{25C} , the above equations result in $r_{HOT} = 0.409$ and $r_{COLD} = 2.815$. Referencing these ratios to the Vishay Resistance-Temperature curve 2 chart gives a hot trip point of about 50°C and a cold trip point of about 0°C. The difference between the hot and cold trip points is approximately 50°C.

By using a bias resistor, R_{NOM} , different in value from R_{25C} , the hot and cold trip points can be moved in either direction. The temperature span will change somewhat due to the nonlinear behavior of the thermistor. The following

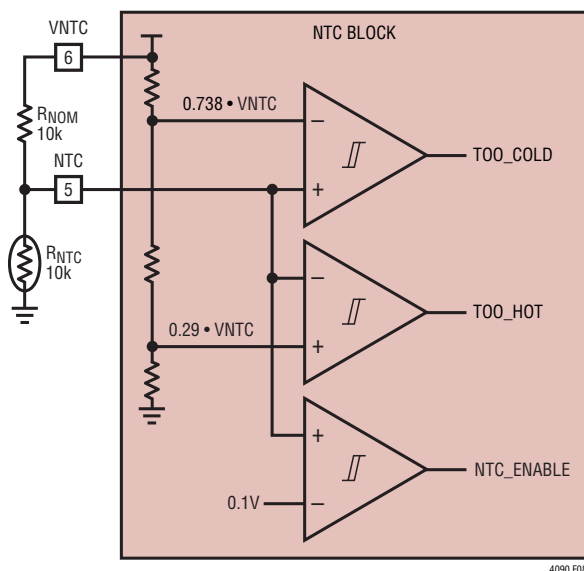

Figure 8. Typical NTC Thermistor Circuit

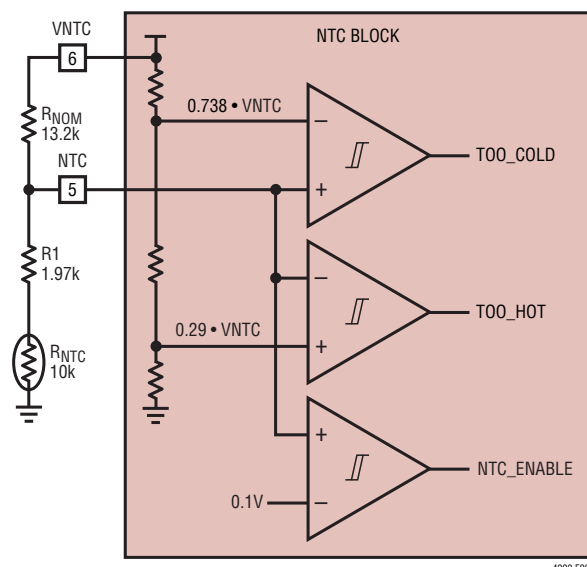

Figure 9. NTC Thermistor Circuit with Additional Bias Resistor

4090fe

APPLICATIONS INFORMATION

equations can be used to easily calculate a new value for the bias resistor:

$$R_{\text{NOM}} = \frac{r_{\text{HOT}}}{0.409} \cdot R_{25\text{C}}$$

$$R_{\text{NOM}} = \frac{r_{\text{COLD}}}{2.815} \cdot R_{25\text{C}}$$

where r_{HOT} and r_{COLD} are the resistance ratios at the desired hot and cold trip points. Note that these equations are linked. Therefore, only one of the two trip points can be chosen, the other is determined by the default ratios designed in the IC. Consider an example where a 40°C hot trip point is desired.

From the Vishay curve 2 R-T characteristics, r_{HOT} is 0.5758 at 40°C. Using the above equation, R_{NOM} should be set to 14.0k. With this value of R_{NOM} , the cold trip point is about -7°C. Notice that the span is now 47°C rather than the previous 50°C. This is due to the increase in temperature gain of the thermistor as absolute temperature decreases.

The upper and lower temperature trip points can be independently programmed by using an additional bias resistor as shown in Figure 9. The following formulas can be used to compute the values of R_{NOM} and $R1$:

$$R_{\text{NOM}} = \frac{r_{\text{COLD}} - r_{\text{HOT}}}{2.815} \cdot R_{25\text{C}}$$

$$R1 = 0.409 \cdot R_{\text{NOM}} - r_{\text{HOT}} \cdot R_{25\text{C}}$$

For example, to set the trip points to -5°C and 55°C with a Vishay curve 2 thermistor choose

$$R_{\text{NOM}} = \frac{3.532 - 0.3467}{2.815 - 0.409} \cdot 10\text{k} = 13.2\text{k}$$

the nearest 1% value is 13.3k.

$$R1 = 0.409 \cdot 13.3\text{k} - 0.3467 \cdot 10\text{k} = 1.97\text{k}$$

the nearest 1% value is 1.96k. The final solution is shown in Figure 9 and results in an upper trip point of 55°C and a lower trip point of -5°C.

Power Dissipation and High Temperature Considerations

The die temperature of the LTC4090/LTC4090-5 must be lower than the maximum rating of 110°C. This is generally

not a concern unless the ambient temperature is above 85°C. The total power dissipated inside the LTC4090/LTC4090-5 depend on many factors, including input voltage (IN or HVIN), battery voltage, programmed charge current, programmed input current limit, and load current.

In general, if the LTC4090/LTC4090-5 is being powered from IN the power dissipation can be calculated as follows:

$$P_D = (V_{\text{IN}} - V_{\text{BAT}}) \cdot I_{\text{BAT}} + (V_{\text{IN}} - V_{\text{OUT}}) \cdot I_{\text{OUT}}$$

where P_D is the power dissipated, I_{BAT} is the battery charge current, and I_{OUT} is the application load current. For a typical application, an example of this calculation would be:

$$P_D = (5\text{V} - 3.7\text{V}) \cdot 0.4\text{A} + (5\text{V} - 4.75\text{V}) \cdot 0.1\text{A} = 545\text{mW}$$

This examples assumes $V_{\text{IN}} = 5\text{V}$, $V_{\text{OUT}} = 4.75\text{V}$, $V_{\text{BAT}} = 3.7\text{V}$, $I_{\text{BAT}} = 400\text{mA}$, and $I_{\text{OUT}} = 100\text{mA}$ resulting in slightly more than 0.5W total dissipation.

If the LTC4090 is being powered from HVIN, the power dissipation can be estimated by calculating the regulator power loss from an efficiency measurement, and subtracting the catch diode loss.

$$P_D = (1 - \eta) \cdot [V_{\text{HVOUT}} \cdot (I_{\text{BAT}} + I_{\text{OUT}})] - V_D \cdot \left(1 - \frac{V_{\text{HVOUT}}}{V_{\text{HVIN}}}\right) \cdot (I_{\text{BAT}} + I_{\text{OUT}}) + 0.3\text{V} \cdot I_{\text{BAT}}$$

where η is the efficiency of the high voltage regulator and V_D is the forward voltage of the catch diode at $I = I_{\text{BAT}} + I_{\text{OUT}}$. The first term corresponds to the power lost in converting V_{HVIN} to V_{HVOUT} , the second term subtracts the catch diode loss, and the third term is the power dissipated in the battery charger. For a typical application, an example of this calculation would be:

$$P_D = (1 - 0.87) \cdot [4\text{V} \cdot (1\text{A} + 0.6\text{A})] - 0.4\text{V} \cdot \left(1 - \frac{4\text{V}}{12\text{V}}\right) \cdot (1\text{A} + 0.6\text{A}) + 0.3\text{V} \cdot 1\text{A} = 0.7\text{W}$$

This example assumes 87% efficiency, $V_{\text{HVIN}} = 12\text{V}$, $V_{\text{BAT}} = 3.7\text{V}$ (V_{HVOUT} is about 4V), $I_{\text{BAT}} = 1\text{A}$, $I_{\text{OUT}} = 600\text{mA}$ resulting in about 0.7W total dissipation. If the LTC4090-5 is being powered from HVIN, the power dissipation can be estimated

APPLICATIONS INFORMATION

by calculating the regulator power loss from an efficiency measurement, and subtracting the catch diode loss.

$$P_D = (1 - \eta) \cdot (5V \cdot (I_{BAT} + I_{OUT})) - V_D \cdot \left(1 - \frac{5V}{V_{HVIN}} \right) \cdot (I_{BAT} + I_{OUT}) + (5V - V_{BAT}) \cdot I_{BAT}$$

The difference between this equation and that for the LTC4090 is the last term, which represents the power dissipation in the battery charger. For a typical application, an example of this calculation would be:

$$P_D = (1 - 0.87) \cdot (5V \cdot (1A + 0.6A)) - 0.4V \cdot \left(1 - \frac{5V}{12V} \right) \cdot (1A + 0.6A) + (5V - 3.7V) \cdot 1A = 1.97W$$

Like the LTC4090 example, this examples assumes 87% efficiency, $V_{HVIN} = 12V$, $V_{BAT} = 3.7V$, $I_{BAT} = 1A$ and $I_{OUT} = 600mA$ resulting in about 2W total power dissipation.

It is important to solder the exposed backside of the package to a ground plane. This ground should be tied to other copper layers below with thermal vias; these layers will spread the heat dissipated by the LTC4090/LTC4090-5. Additional vias should be placed near the catch diode. Adding more copper to the top and bottom layers and tying this copper to the internal planes with vias can

reduce thermal resistance further. With these steps, the thermal resistance from die (i.e., junction) to ambient can be reduced to $\theta_{JA} = 40^\circ C/W$.

Board Layout Considerations

As discussed in the previous section, it is critical that the exposed metal pad on the backside of the LTC4090/LTC4090-5 package be soldered to the PC board ground. Furthermore, proper operation and minimum EMI requires a careful printed circuit board (PCB) layout. Note that large, switched currents flow in the power switch (between the HVIN and SW pins), the catch diode and the HVIN input capacitor. These components, along with the inductor and output capacitor, should be placed on the same side of the circuit board, and their connections should be made on that layer. Place a local, unbroken ground plane below these components. The loop formed by these components should be as small as possible.

Additionally, the SW and BOOST nodes should be kept as small as possible. Figure 10 shows the recommended component placement with trace and via locations.

High frequency currents, such as the high voltage input current of the LTC4090/LTC4090-5, tend to find their way along the ground plane on a mirror path directly beneath the incident path on the top of the board. If there are slits or cuts in the ground plane due to other traces on that layer, the current will be forced to go around the slits. If high frequency currents are not allowed to flow back through their natural least-area path, excessive voltage will build up and radiated emissions will occur. See Figure 11.

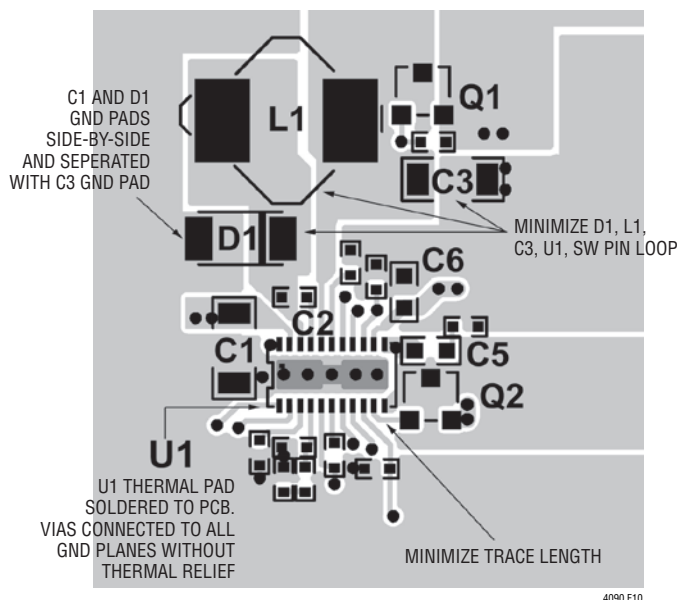

Figure 10. Suggested Board Layout

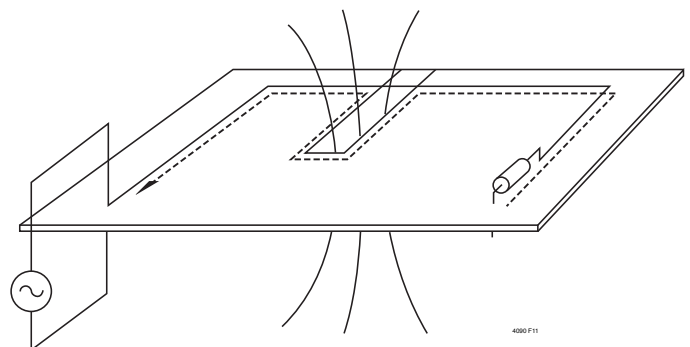

Figure 11. Ground Currents Follow Their Incident Path at High Speed. Slits in the Ground Plane Cause High Voltage and Increased Emissions.

APPLICATIONS INFORMATION

IN and HVIN Bypass Capacitor

Many types of capacitors can be used for input bypassing; however, caution must be exercised when using multilayer ceramic capacitors. Because of the self-resonant and high Q characteristics of some types of ceramic capacitors, high voltage transients can be generated under some start-up conditions, such as from connecting the charger input to a hot power source. For more information, refer to Application Note 88.

Battery Charger Stability Considerations

The constant-voltage mode feedback loop is stable without any compensation when a battery is connected with low impedance leads. Excessive lead length, however, may add enough series inductance to require a bypass capacitor of at least $1\mu\text{F}$ from BAT to GND. Furthermore, a $4.7\mu\text{F}$ capacitor with a 0.2Ω to 1Ω series resistor to GND is recommended at the BAT pin to keep ripple voltage low when the battery is disconnected.

TYPICAL APPLICATIONS

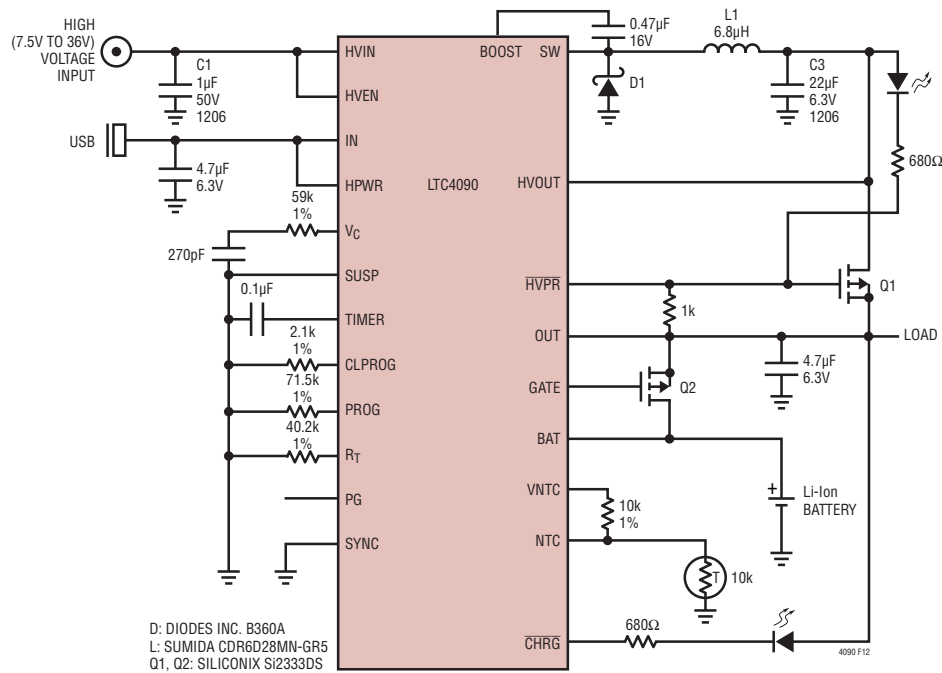
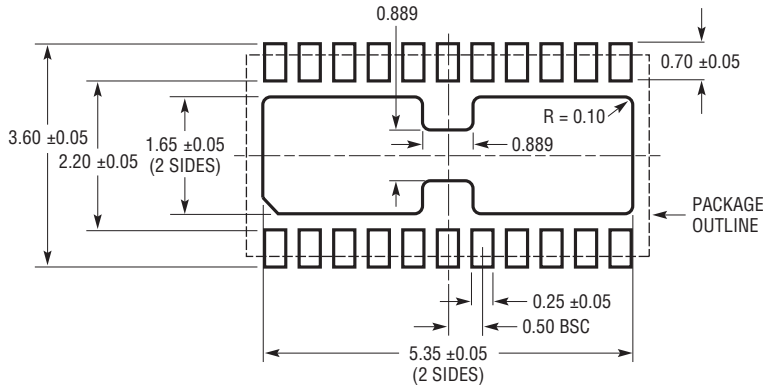

Figure 12. 800kHz Switching Frequency

PACKAGE DESCRIPTION

Please refer to <http://www.linear.com/product/LTC4090#packaging> for the most recent package drawings.

DJC Package
22-Lead Plastic DFN (6mm × 3mm)
 (Reference LTC DWG # 05-08-1714 Rev 0)



RECOMMENDED SOLDER PAD PITCH AND DIMENSIONS

NOTE:

1. DIMENSIONS ARE IN MILLIMETERS
2. APPLY SOLDER MASK TO AREAS THAT ARE NOT SOLDERED
3. DRAWING IS NOT TO SCALE

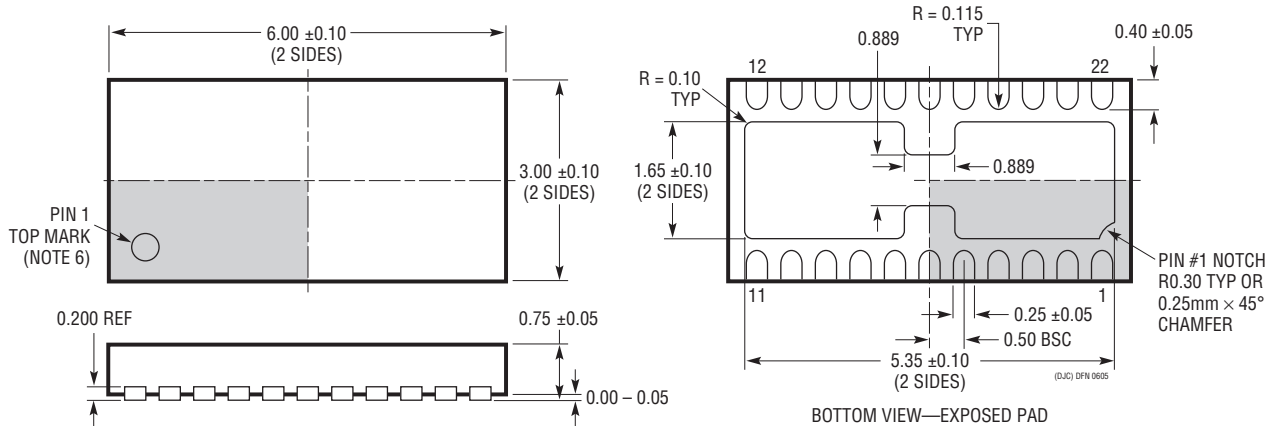

NOTE:

1. DRAWING PROPOSED TO BE MADE VARIATION OF VERSION (WXXX) IN JEDEC PACKAGE OUTLINE MO-229
2. DRAWING NOT TO SCALE
3. ALL DIMENSIONS ARE IN MILLIMETERS
4. DIMENSIONS OF EXPOSED PAD ON BOTTOM OF PACKAGE DO NOT INCLUDE MOLD FLASH. MOLD FLASH, IF PRESENT, SHALL NOT EXCEED 0.15mm ON ANY SIDE
5. EXPOSED PAD SHALL BE SOLDER PLATED
6. SHADED AREA IS ONLY A REFERENCE FOR PIN 1 LOCATION ON TOP AND BOTTOM OF PACKAGE

REVISION HISTORY

REV	DATE	DESCRIPTION	PAGE NUMBER
D	03/15	Corrected comparator hookup on block diagram	11
E	07/17	Removed Temp Dot from I_{VNTC}	5

RELATED PARTS

PART NUMBER	DESCRIPTION	COMMENTS
Battery Chargers		
LTC1733	Monolithic Lithium-Ion Linear Battery Charger	Standalone Charger with Programmable Timer, Up to 1.5A Charge Current
LTC1734	Lithium-Ion Linear Battery Charger in ThinSOT™	Simple ThinSOT Charger, No Blocking Diode, No Sense Resistor Needed
LTC4002	Switch Mode Lithium-Ion Battery Charger	Standalone, $4.7V \leq V_{IN} \leq 24V$, 500kHz Frequency, Three-Hour Charge Termination
LTC4053	USB Compatible Monolithic Li-Ion Battery Charger	Standalone Charger with Programmable Timer, Up to 1.25A Charge Current
LTC4054	Standalone Linear Li-Ion Battery Charger with Integrated Pass Transistor in ThinSOT	Thermal Regulation Prevents Overheating, C/10 Termination, C/10 Indicator, Up to 800mA Charge Current
LTC4057	Lithium-Ion Linear Battery Charger	Up to 800mA Charge Current, Thermal Regulation, ThinSOT Package
LTC4058	Standalone 950mA Lithium-Ion Charger in DFN	C/10 Charge Termination, Battery Kelvin Sensing, $\pm 7\%$ Charge Accuracy
LTC4059	900mA Linear Lithium-Ion Battery Charger	2mm \times 2mm DFN Package, Thermal Regulation, Charge Current Monitor Output
LTC4065/ LTC4065A	Standalone Li-Ion Battery Chargers in 2mm \times 2mm DFN	4.2V, $\pm 0.6\%$ Float Voltage, Up to 750mA Charge Current, 2mm \times 2mm DFN, "A" Version Has ACPR Function.
LTC4095	Standalone USB Lithium-Ion/Polymer Battery Charger in 2mm \times 2mm DFN	950mA Charge Current, Timer Termination + C/10 Detection Output, 4.2V, 0.6% Accurate Float Voltage, Four CHRG Pin Indicator States
Power Management		
LTC3406/ LTC3406A	600mA (I_{OUT}), 1.5MHz, Synchronous Step-Down DC/DC Converter	95% Efficiency, V_{IN} : 2.5V to 5.5V, $V_{OUT} = 0.6V$, $I_Q = 20\mu A$, $I_{SD} < 1\mu A$, ThinSOT Package
LTC3411	1.25A (I_{OUT}), 4MHz, Synchronous Step-Down DC/DC Converter	95% Efficiency, V_{IN} : 2.5V to 5.5V, $V_{OUT} = 0.8V$, $I_Q = 60\mu A$, $I_{SD} < 1\mu A$, MS10 Package
LTC3440	600mA (I_{OUT}), 2MHz, Synchronous Buck-Boost DC/DC Converter	95% Efficiency, V_{IN} : 2.5V to 5.5V, $V_{OUT} = 2.5V$, $I_Q = 25\mu A$, $I_{SD} < 1\mu A$, MS Package
LTC3455	Dual DC/DC Converter with USB Power Manager and Li-Ion Battery Charger	Seamless Transition Between Power Sources: USB, Wall Adapter and Battery; 95% Efficient DC/DC Conversion
LT3493	1.2A, 750kHz Step-Down Switching Regulator	88% Efficiency, V_{IN} : 3.6V to 36V (40V Maximum), $V_{OUT} = 0.8V$, $I_{SD} < 2\mu A$, 2mm \times 3mm DFN Package
LTC4055	USB Power Controller and Battery Charger	Charges Single-Cell Li-Ion Batteries Directly from a USB Port, Thermal Regulation, 200m Ω Ideal Diode, 4mm \times 4mm QFN16 Package
LTC4066	USB Power Controller and Li-Ion Battery Charger with Low Loss Ideal Diode	Charges Single-Cell Li-Ion Batteries Directly from a USB Port, Thermal Regulation, 50m Ω Ideal Diode, 4mm \times 4mm QFN24 Package
LTC4067	USB Power Controller with OVP, Ideal Diode and Li-Ion Battery Charger	13V Overvoltage Transient Protection, Thermal Regulation, 200m Ω Ideal Diode with <50m Ω Option, 4mm \times 3mm DFN-14 Package
LTC4085	USB Power Manager with Ideal Diode Controller and Li-Ion Charger	Charges Single-Cell Li-Ion Batteries Directly from a USB Port, Thermal Regulation, 200m Ω Ideal Diode with <50m Ω Option, 4mm \times 3mm DFN14 Package
LTC4089/ LTC4089-5	USB Power Manager with Ideal Diode Controller and High Efficiency Li-Ion Battery Charger	High Efficiency 1.2A Charger from 6V to 36V (40V Max) Input Charges Single-Cell Li-Ion Batteries Directly from a USB Port, Thermal Regulation, 200m Ω Ideal Diode with <50m Ω Option, Bat-Track Adaptive Output Control (LTC4089), Fixed 5V Output (LTC4089-5), 6mm \times 3mm DFN-22 Package
LTC4411/LTC4412	Low Loss PowerPath Controller in ThinSOT	Automatic Switching Between DC Sources, Load Sharing, Replaces ORing Diode
LTC4412HV	High Voltage Power Path Controllers in ThinSOT	V_{IN} : 3V to 36V, More Efficient than Diode ORing, Automatic Switching Between DC Sources, Simplified Load Sharing, ThinSOT Package.

Looking for pricing, stock, or lifecycle information?

Click below to explore more details on WIN SOURCE:

- ⊖ [View LTC4090EDJC#TRPBF on WIN SOURCE](#)
- ⊖ [Linear Technology Information](#)

Optimize Your Supply Chain with WIN SOURCE Solutions

- ✓ Global Sourcing Solution
- ✓ Obsolete Management
- ✓ Cost Control Management
- ✓ Shortage Management
- ✓ Alternative Solution
- ✓ Excess Inventory Management