



# THE DATASHEET OF DC1580A



# LTC3856EUH

## HIGH EFFICIENCY POLYPHASE BUCK CONVERTER

### DESCRIPTION

Demonstration circuit 1580A is a high efficiency, polyphase, synchronous buck converter with 4.5V to 14V input range. It can supply 50A maximum load current at 1.5V output. The demo board uses the LTC®3856EUH controller. The LTC3856 is a feature-rich single-output dual-phase synchronous buck controller with on-chip drivers, remote output voltage sensing. This board is setup with sense resistor configuration with optional inductor DCR sensing circuit. Temperature compensation function can guarantee accurate current limit over a wide temperature range with DCR sensing. Stage shedding function allows the controller to decrease the phase number to be one at the light load condition in order to save switching related loss. Adaptive voltage positioning (AVP) can help improve the transient response. The LTC3856 is suitable for input from 4.5V to 38V and output up to 5V. The LTC3856 can provide high efficiency, high power density and versatile power solutions for telecom and datacom systems, industrial and medical instruments, DC power distribution systems and computer systems. The controller is available in 32-pin 5mm × 5mm QFN and 38-pin SSOP packages.

The RUN pin (JP1) provides enable feature. To shut down the converter, one simple way is to force the RUN pin below 1.2V (JP1: OFF). Use JP3 jumper to select burst mode, stage shedding mode or forced continuous mode operation. The phase of CLKOUT is set by JP2. Switching frequency is pre-set at about 400KHz, and it can be easily modified from 250KHz to 770KHz. Please see LTC3856 data sheet for detailed information.

**Design files for this circuit board are available. Call the LTC factory.**

**Table 1. Performance Summary (T<sub>A</sub> = 25°C)**

PARAMETER	CONDITION	VALUE
Input Voltage Range		4.5V to 14V
Output Voltage, V <sub>OUT</sub>	V <sub>IN</sub> = 4.5-14V, I <sub>OUT</sub> = 0A to 50A	1.5V ±2%
Maximum Output Current, I <sub>OUT</sub>	V <sub>IN</sub> = 4.5-14V, V <sub>OUT</sub> = 1.5V	50A
Typical Efficiency	V <sub>IN</sub> = 12V, V <sub>OUT</sub> = 1.5V, I <sub>OUT</sub> = 50A	87.7%
Typical Switching Frequency		400kHz

## QUICK START PROCEDURE

Demonstration circuit 1580A is easy to set up to evaluate the performance of the LTC3856EUH. Refer to Figure 1 for the proper measurement equipment setup and follow the procedure below:

1. With power off, connect the input power supply to  $V_{in}$  (4.5V-14V) and GND (input return).
2. Connect the 1.5V output load between  $V_{out}$  and GND (Initial load: no load).
3. Connect the DVMs to the input and outputs.
4. Turn on the input power supply and check for the proper output voltages.  $V_{out}$  should be  $1.5V \pm 2\%$ .
5. Once the proper output voltages are established, adjust the loads within the operating range and observe the output voltage regulation, ripple voltage and other parameters.

Note: When measuring the output or input voltage ripple, do not use the long ground lead on the oscilloscope probe. See Figure 2 for the proper scope probe technique. Short, stiff leads need to be soldered to the (+) and (-) terminals of an output capacitor. The probe's ground ring needs to touch the (-) lead and the probe tip needs to touch the (+) lead.

# LTC3856EUH

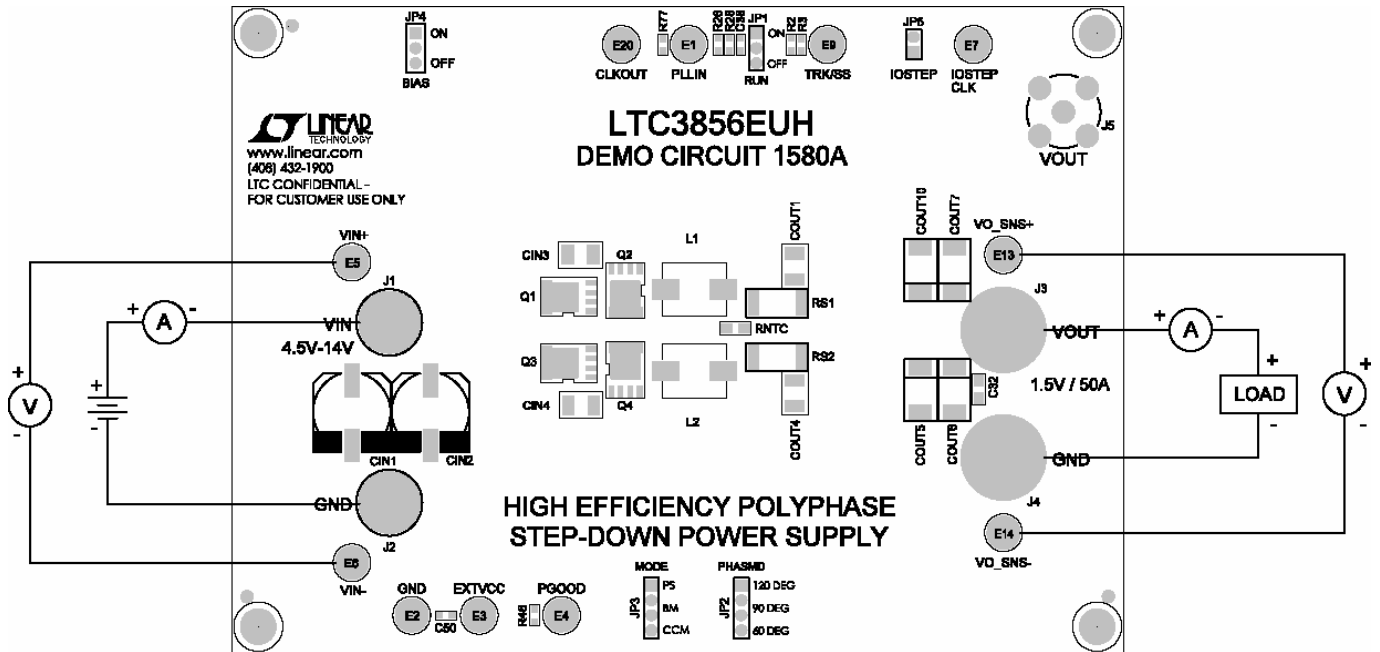

Figure 1. Proper Measurement Equipment Setup

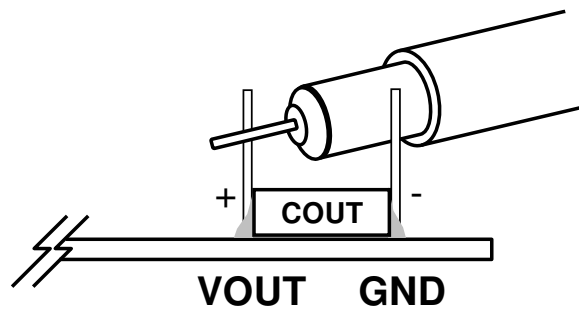

Figure 2. Measuring Output Voltage Ripple

# LTC3856EUH

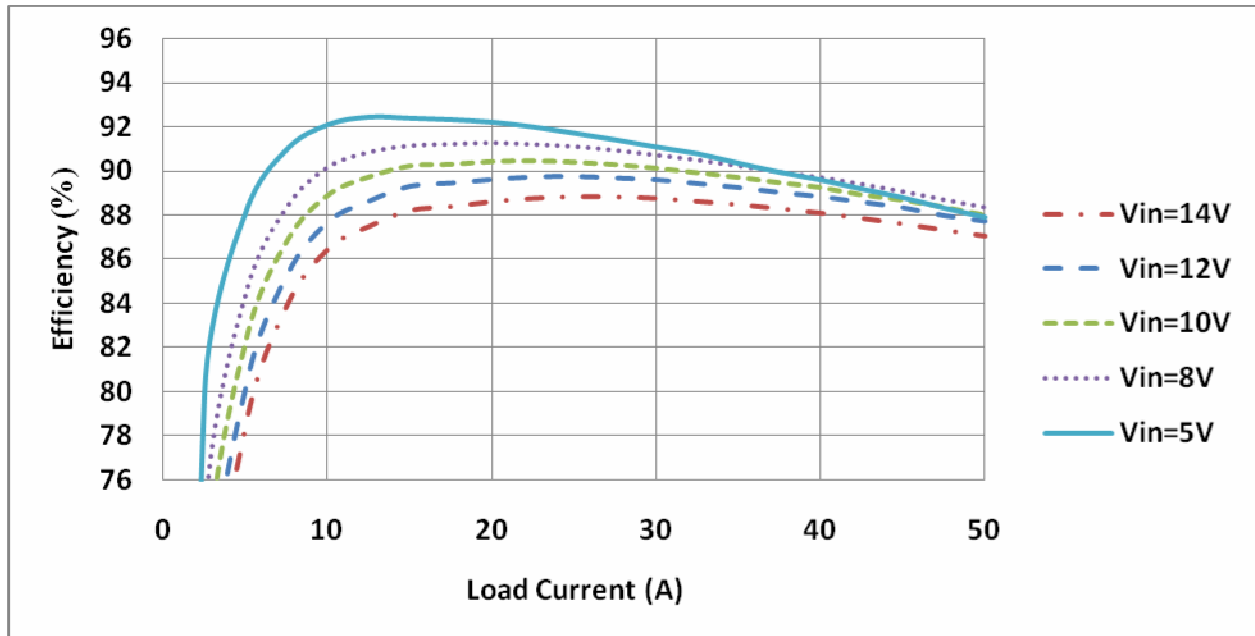
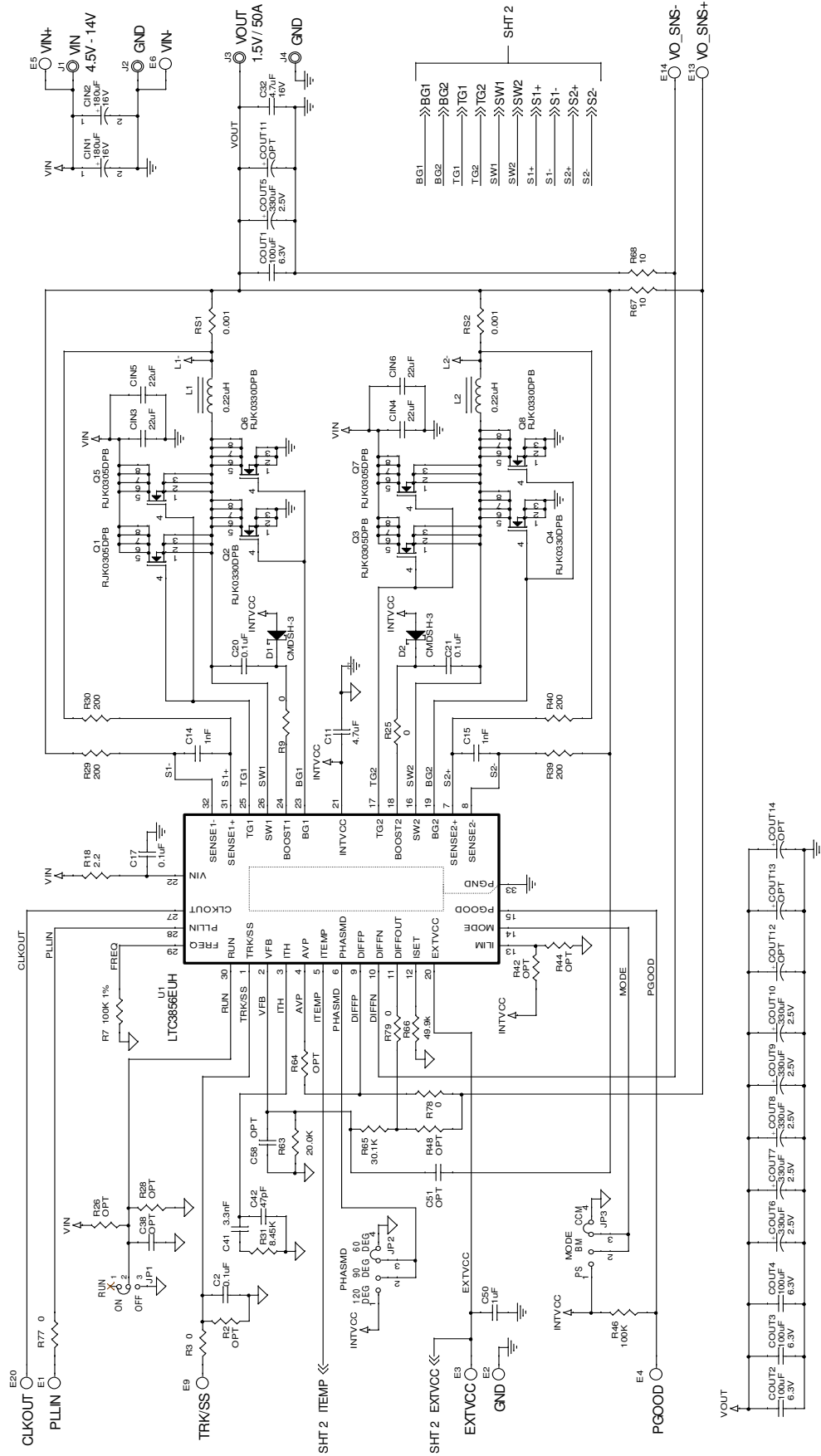
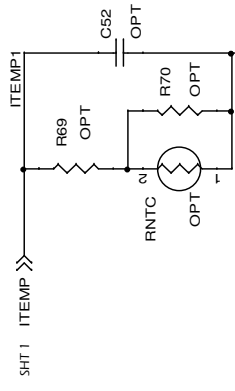

Figure 3. Efficiency vs load current

# LTC3856EUH



TEMPERATURE COMPENSATION NETWORK FOR DCR SENSING



OPTIONAL DCR SENSING

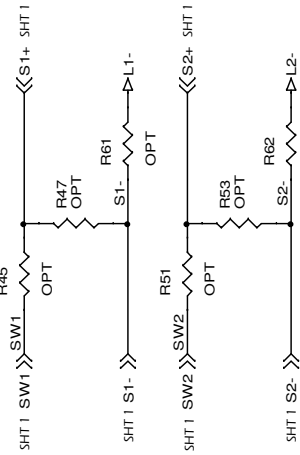

NOTE:  
WHEN DCR SENSING IS IMPLEMENTED, SHORT RSENSE1  
AND RSENSE2. DO NOT SHORT R29, R30, R39 AND R40

LOAD STEP CKT

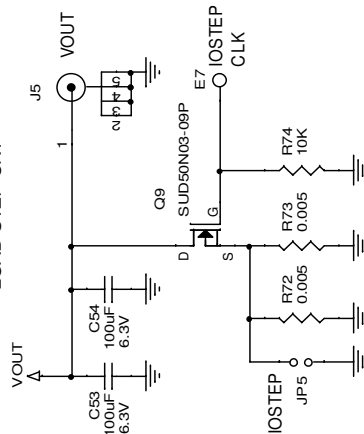

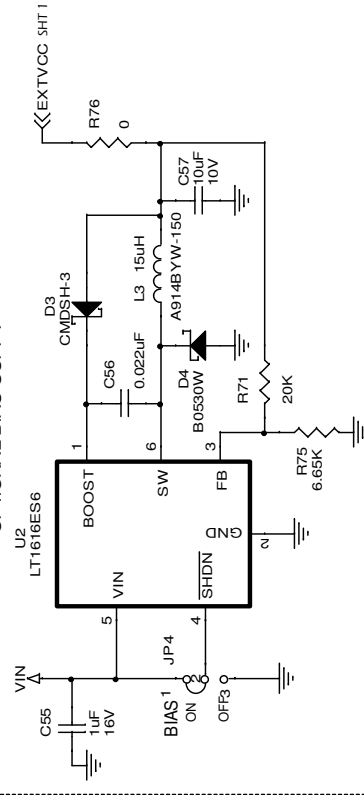

OPTIONAL BIAS SUPPLY



## Looking for pricing, stock, or lifecycle information?

Click below to explore more details on WIN SOURCE:

-  [View DC1580A on WIN SOURCE](#)
-  [Analog Devices Inc. Information](#)

## Optimize Your Supply Chain with WIN SOURCE Solutions

-  Global Sourcing Solution
-  Obsolete Management
-  Cost Control Management
-  Shortage Management
-  Alternative Solution
-  Excess Inventory Management