

Dual 2-Phase, No R_{SENSE} TM, Synchronous Controller for DDR/QDR Memory Termination

FEATURES

- No Current Sense Resistors Required
- Out-of-Phase Controllers Reduce Required Input Capacitance
- V_{OUT2} Tracks $1/2 V_{REF}$
- Symmetrical Source/Sink Output Current Capability (V_{OUT2})
- Spread Spectrum Operation (When Enabled)
- Wide V_{IN} Range: 2.75V to 9.8V
- Constant Frequency Current Mode Operation
- $0.6V \pm 1.5\%$ Voltage Reference (V_{OUT1})
- Low Dropout Operation: 100% Duty Cycle
- True PLL for Frequency Locking or Adjustment
- Internal Soft-Start Circuitry
- Power Good Output Voltage Monitor
- Output Overvoltage Protection
- Micropower Shutdown: $I_Q = 9\mu A$
- Tiny Low Profile (4mm × 4mm) QFN and Narrow SSOP Packages

APPLICATIONS

- DDR, DDR II and QDR Memory
- SSTL, HSTL Termination Supplies
- Servers, RAID Systems
- Distributed DC Power Systems

DESCRIPTION

The LTC[®]3776 is a 2-phase dual output synchronous step-down switching regulator controller for DDR/QDR memory termination applications. The second controller regulates its output voltage to $1/2 V_{REF}$ while providing symmetrical source and sink output current capability.

The No R_{SENSE} constant frequency current mode architecture eliminates the need for sense resistors and improves efficiency. Power loss and noise due to the ESR of the input capacitance are minimized by operating the two controllers out of phase.

The switching frequency can be programmed up to 750kHz, allowing the use of small surface mount inductors and capacitors. For noise sensitive applications, the LTC3776 switching frequency can be externally synchronized from 250kHz to 850kHz, or can be enabled for spread spectrum operation. Forced continuous operation reduces noise and RF interference. Soft-start for V_{OUT1} is provided internally and can be extended using an external capacitor.

The LTC3776 is available in the tiny thermally enhanced (4mm × 4mm) QFN package or 24-lead SSOP narrow package.

LT, **LT**, **LTC** and **LTM** are registered trademarks of Linear Technology Corporation. **Burst Mode** is a registered trademark of Linear Technology Corporation. **No R_{SENSE}** is a trademark of Linear Technology Corporation. All other trademarks are the property of their respective owners. Protected by U.S. Patents including 5481178, 5929620, 6144194, 6580258, 6304066, 6611131, 6498466, patent pending on Spread Spectrum.

TYPICAL APPLICATION

High Efficiency, 2-Phase, DDR Memory (V_{DDQ} and V_{TT}) Supplies

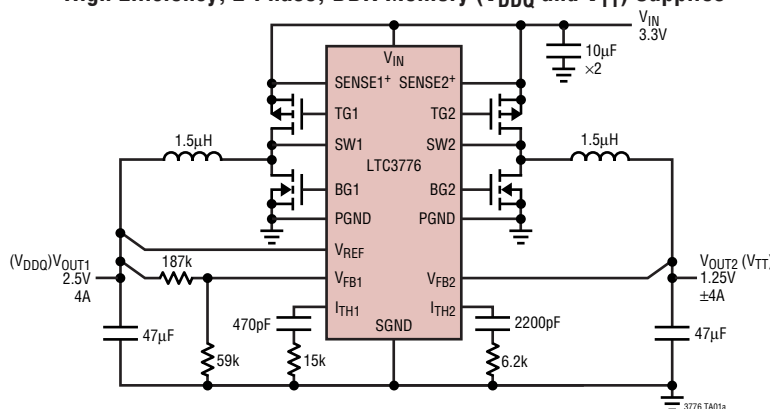

Efficiency vs Load Current

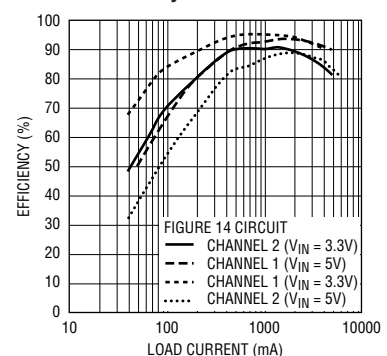

ABSOLUTE MAXIMUM RATINGS (Note 1)

Input Supply Voltage (V_{IN})	-0.3V to 10V	TG1, TG2, BG1, BG2 Peak Output Current ($<10\mu s$)	1A
PLLLPF, RUN/SS, SYNC/SSEN, V_{REF} , SENSE1+, SENSE2+, V_{FB2}		Operating Temperature Range (Note 2)	-40°C to 85°C
IPRG1, IPRG2 Voltages	-0.3V to ($V_{IN} + 0.3V$)	Storage Temperature Range	-65°C to 125°C
V_{FB1} , I_{TH1} , I_{TH2} Voltages	-0.3V to 2.4V	Junction Temperature (Note 3)	125°C
SW1, SW2 Voltages	-2V to $V_{IN} + 1V$ (10V Max)	Lead Temperature (Soldering, 10 sec)	(LTC3776EGN) 300°C
PGOOD	-0.3V to 10V		

PACKAGE/ORDER INFORMATION

<p>TOP VIEW</p> <p>UF PACKAGE 24-LEAD (4mm x 4mm) PLASTIC QFN $T_{JMAX} = 125^{\circ}C$, $\theta_{JA} = 37^{\circ}C/W$ EXPOSED PAD (PIN 25) IS PGND MUST BE SOLDERED TO PCB</p>	ORDER PART NUMBER	<p>TOP VIEW</p> <p>GN PACKAGE 24-LEAD PLASTIC SSOP $T_{JMAX} = 125^{\circ}C$, $\theta_{JA} = 130^{\circ}C/W$</p>	ORDER PART NUMBER
	LTC3776EUF		LTC3776EGN
	UF PART MARKING		
	3776		

Consult LTC Marketing for parts specified with wider operating temperature ranges.

ELECTRICAL CHARACTERISTICS

The ● denotes specifications that apply over the full operating temperature range, otherwise specifications are at $T_A = 25^{\circ}C$. $V_{IN} = 4.2V$ unless otherwise specified.

PARAMETER	CONDITIONS	MIN	TYP	MAX	UNITS
Main Control Loops					
Input DC Supply Current	(Note 4)				
Normal Operation	$I_{TH1} = I_{TH2} = 1.3V$		575	850	μA
Shutdown	RUN/SS = 0V		9	20	μA
UVLO	$V_{IN} < UVLO$ Threshold -200mV		3	10	μA
Undervoltage Lockout Threshold	V_{IN} Falling	● 1.95	2.25	2.55	V
	V_{IN} Rising	● 2.15	2.45	2.75	V
Shutdown Threshold at RUN/SS		0.45	0.65	0.85	V
Start-Up Current Source	RUN/SS = 0V	0.4	0.7	1	μA
Regulated Feedback Voltage (V_{FB1})	0°C to 85°C (Note 5)	0.591	0.6	0.609	V
	-40°C to 85°C	● 0.588	0.6	0.612	V
Regulated Feedback Voltage (V_{FB2})	$V_{REF} = 2.5V$	● 1.232	1.250	1.268	V
Output Voltage Line Regulation (V_{FB1})	2.75V < V_{IN} < 9.8V (Note 5)		0.05	0.2	mV/V
Output Voltage Line Regulation (V_{FB2})			0.02	0.1	mV/V

ELECTRICAL CHARACTERISTICS

The ● denotes specifications that apply over the full operating temperature range, otherwise specifications are at $T_A = 25^\circ\text{C}$. $V_{IN} = 4.2\text{V}$ unless otherwise specified.

PARAMETER	CONDITIONS	MIN	TYP	MAX	UNITS
Output Voltage Load Regulation	$I_{TH} = 0.9\text{V}$ (Note 5) $I_{TH} = 1.7\text{V}$		0.12 -0.12	0.5 -0.5	% %
V_{FB1} Input Current	(Note 5)		10	50	nA
Overvoltage Protect Threshold	Measured at V_{FB} with Respect to Regulated Feedback Voltage	10	13.3	16	%
Overvoltage Protect Hysteresis			3		%
Top Gate (TG) Drive 1, 2 Rise Time	$C_L = 3000\text{pF}$		40		ns
Top Gate (TG) Drive 1, 2 Fall Time	$C_L = 3000\text{pF}$		40		ns
Bottom Gate (BG) Drive 1, 2 Rise Time	$C_L = 3000\text{pF}$		50		ns
Bottom Gate (BG) Drive 1, 2 Fall Time	$C_L = 3000\text{pF}$		40		ns
Maximum Current Sense Voltage (Channel 1) (SENSE1+ – SW1)($\Delta V_{SENSE(MAX)}$) (SOURCE)	IPRG1 = Floating (Note 6) IPRG1 = 0V IPRG1 = V_{IN}	● 110 ● 70 ● 185	125 85 204	140 100 223	mV mV mV
Maximum Current Sense Voltage (Channel 2) (SENSE2+ – SW2)($\Delta V_{SENSE(MAX)}$) (SOURCE)	IPRG2 = Floating (Note 6) IPRG2 = 0V IPRG2 = V_{IN}	● 127 ● 85 ● 215	147 100 245	167 115 275	mV mV mV
Minimum Current Sense Voltage (Channel 2 Only) (SENSE2+ – SW2)($\Delta V_{SENSE(MAX)}$) (SINK)	IPRG2 = Floating (Note 6) IPRG2 = 0V IPRG2 = V_{IN}	● -130 ● -90 ● -208	-112 -75 -188	-94 -60 -168	mV mV mV
Soft-Start Time	Time for V_{FB1} to Ramp from 0.05V to 0.55V	0.667	0.833	1	ms
Oscillator and Phase-Locked Loop					
Oscillator Frequency	Spread Spectrum Disabled (SYNC/SSEN = GND) PLLLPF = Floating PLLLPF = 0V PLLLPF = V_{IN}	● 460 ● 260 ● 650	550 300 750	610 340 825	kHz kHz kHz
Spread Spectrum Frequency Range	SYNC/SSEN = V_{IN} Minimum Switching Frequency Maximum Switching Frequency		450 580		kHz kHz
Phase-Locked Loop Lock Range	SYNC/SSEN Clocked Minimum Synchronizable Frequency Maximum Synchronizable Frequency	● 850	200 1150	250	kHz kHz
Phase Detector Output Current Sinking Sourcing	$f_{OSC} > f_{SYNC/FCB}$ $f_{OSC} < f_{SYNC/FCB}$		-4 4		μA μA
PGOOD Output					
PGOOD Voltage Low	I_{PGOOD} Sinking 1mA		125		mV
PGOOD Trip Level	V_{FB} with Respect to Set Output Voltage $V_{FB} <$ Regulated Feedback Voltage, Ramping Positive $V_{FB} <$ Regulated Feedback Voltage, Ramping Negative $V_{FB} >$ Regulated Feedback Voltage, Ramping Negative $V_{FB} >$ Regulated Feedback Voltage, Ramping Positive	-13 -16 7 10	-10.0 -13.3 10.0 13.3	-7 -10 13 16	% % % %

Note 1: Stresses beyond those listed under Absolute Maximum Ratings may cause permanent damage to the device. Exposure to any Absolute Maximum Rating condition for extended periods may affect device reliability and lifetime.

Note 2: The LTC3776E is guaranteed to meet specified performance from 0°C to 70°C . Specifications over the -40°C to 85°C operating range are assured by design, characterization and correlation with statistical process controls.

Note 3: T_J is calculated from the ambient temperature T_A and power dissipation P_D according to the following formula:

$$T_J = T_A + (P_D \cdot \theta_{JA})^\circ\text{C/W}$$

Note 4: Dynamic supply current is higher due to gate charge being delivered at the switching frequency.

Note 5: The LTC3776 is tested in a feedback loop that servos I_{TH} to a specified voltage and measures the resultant V_{FB} voltage.

Note 6: Peak current sense voltage is reduced dependent on duty cycle to a percentage of value as shown in Figure 2.

TYPICAL PERFORMANCE CHARACTERISTICS $T_A = 25^\circ\text{C}$ unless otherwise noted.

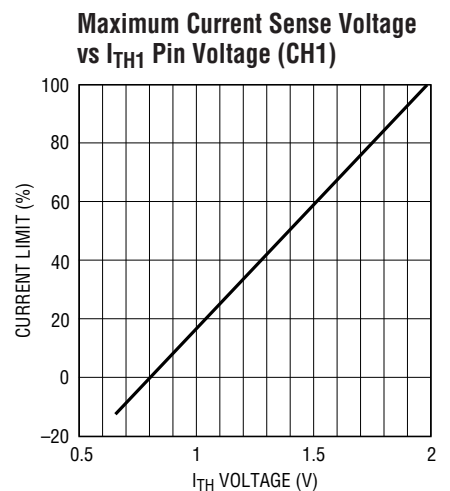
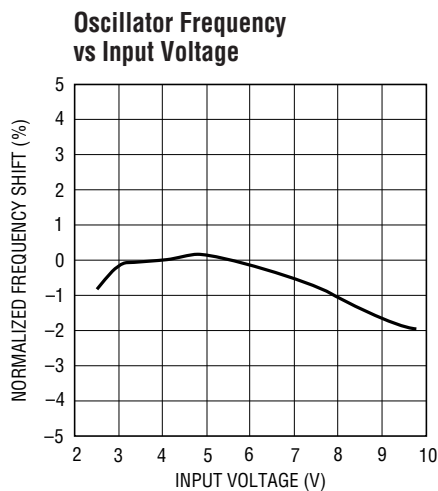
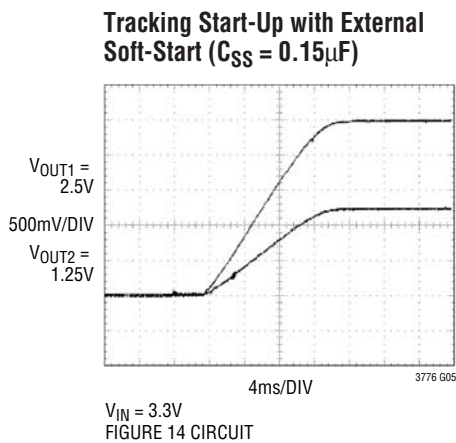
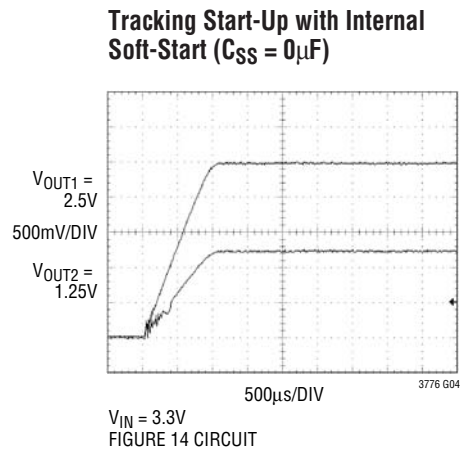
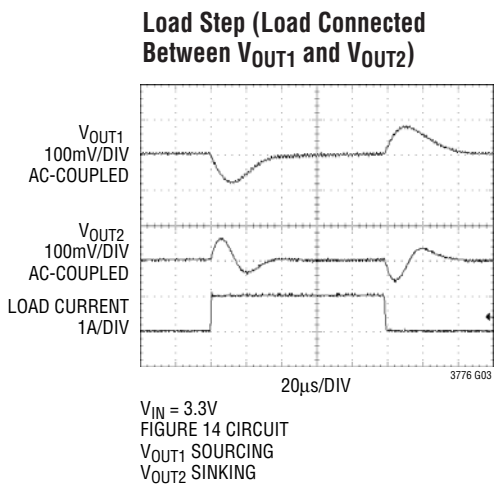
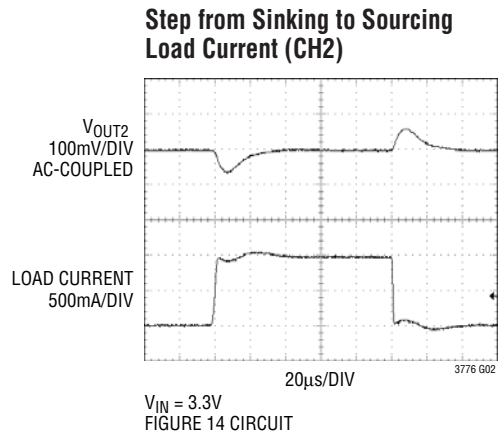
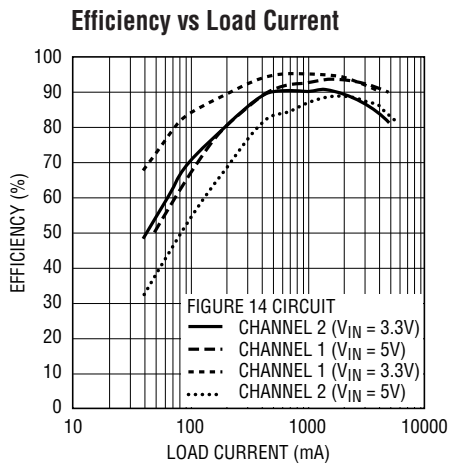

TYPICAL PERFORMANCE CHARACTERISTICS $T_A = 25^\circ\text{C}$ unless otherwise noted.

Maximum Current Sense Voltage vs I_{TH2} Pin Voltage (CH2)

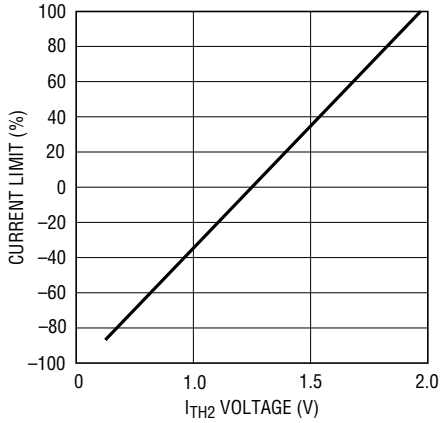

3776 G08

Regulated Feedback Voltage (CH2) vs Temperature

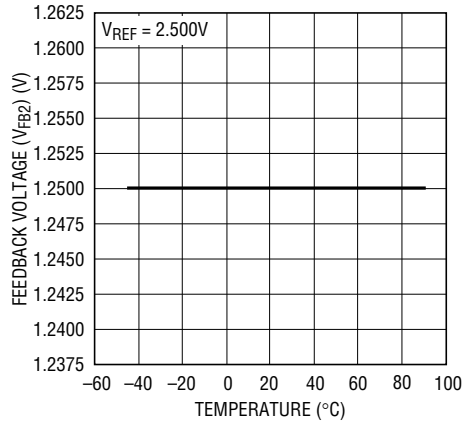

3776 G09

Regulated Feedback Voltage (CH1) vs Temperature

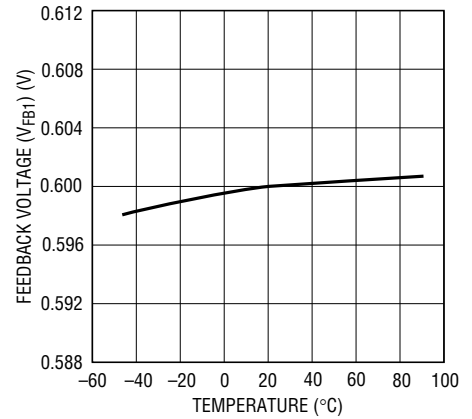

3776 G10

Shutdown (RUN) Threshold vs Temperature

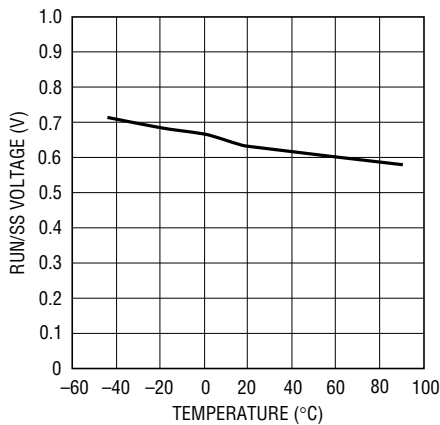

3736 G11

RUN/SS Pull-Up Current vs Temperature

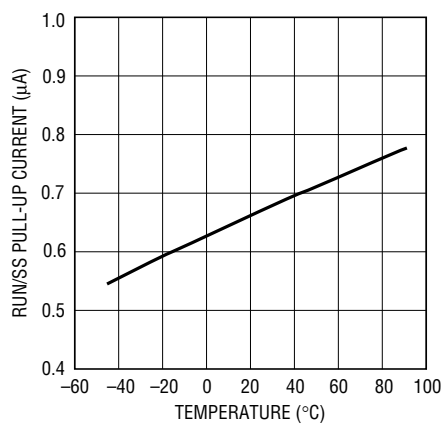

3736 G12

Maximum Current Sense Threshold (CH1) vs Temperature

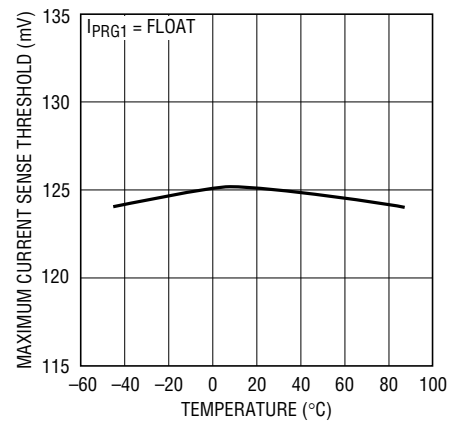

3736 G13

Maximum Current Sense Threshold (CH2) vs Temperature

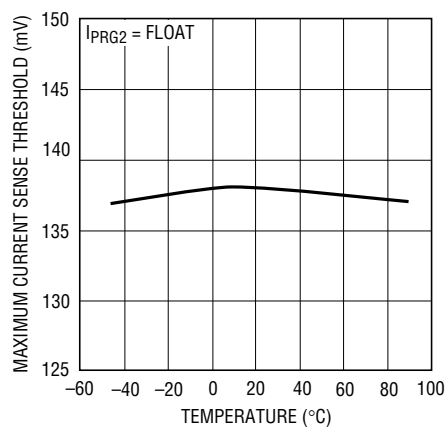

3776 G14

Oscillator Frequency vs Temperature

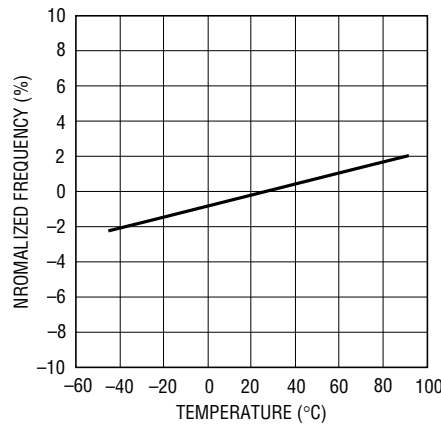

3736 G15

Undervoltage Lockout Threshold vs Temperature

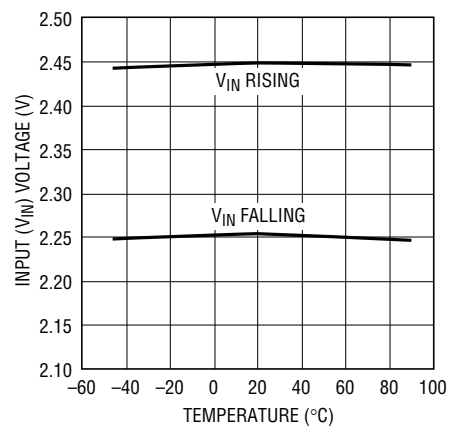

3736 G16

TYPICAL PERFORMANCE CHARACTERISTICS $T_A = 25^\circ\text{C}$ unless otherwise noted.

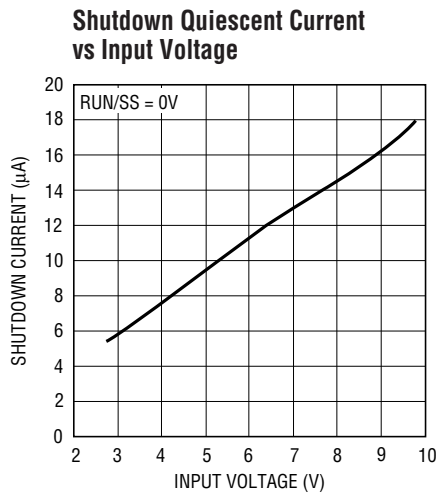

3736 G17

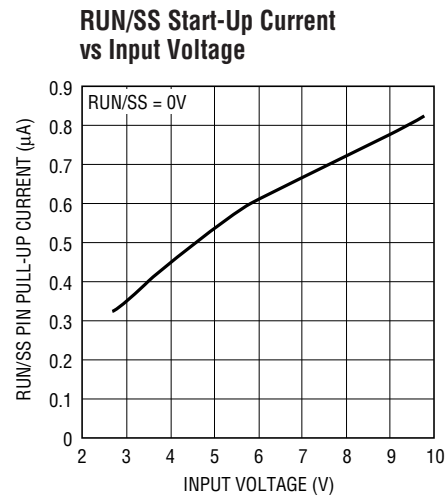

3736 G18

PIN FUNCTIONS (UF/GN Package)

I_{TH1}/I_{TH2} (Pins 1, 8/ Pins 4, 11): Current Threshold and Error Amplifier Compensation Point. Nominal operating range on these pins is from 0.7V to 2V. The voltage on these pins determines the threshold of the main current comparator.

PLLLPF (Pin 3/Pin 6): Frequency Set/PLL Lowpass Filter. When synchronizing to an external clock, this pin serves as the lowpass filter point for the phase-locked loop. Normally a series RC is connected between this pin and ground.

When SYNC/SSEN is tied to GND, this pin serves as the frequency select input. Tying this pin to GND selects 300kHz operation; tying this pin to V_{IN} selects 750kHz operation. Floating this pin selects 550kHz operation. When SYNC/SSEN is tied to V_{IN} to enable spread spectrum operation, a capacitor (1nF to 4.7nF) should be connected from this pin to SGND to filter and smooth the changes in frequency of the LTC3776's internal oscillator.

SGND (Pin 4/Pin 7): Small-Signal Ground. This pin serves as the ground connection for most internal circuits.

V_{IN} (Pin 5/Pin 8): Chip Signal Power Supply. This pin powers the entire chip except for the gate drivers. Externally filtering this pin with a lowpass RC network (e.g., $R = 10\Omega$, $C = 1\mu\text{F}$) is suggested to minimize noise pickup, especially in high load current applications.

V_{REF} (Pin 6/Pin 9): Reference voltage input for channel 2.

The positive input of the error amplifier for channel 2 senses one half of the voltage on this pin through an internal resistor divider.

PGOOD (Pin 9/Pin 12): Power Good Output Voltage Monitor Open-Drain Logic Output. This pin is pulled to ground when the voltage on either feedback pin (V_{FB1} , V_{FB2}) is not within $\pm 13.3\%$ of its nominal set point.

PGND (Pins 12, 16, 20, 25/ Pins 15, 19, 23): Power Ground. These pins serve as the ground connection for the gate drivers and the negative input to the reverse current comparators. The Exposed Pad (UF package) must be soldered to PCB ground.

RUN/SS (Pin 14/Pin 17): Run Control Input and Optional External Soft-Start Input. Forcing this pin below 0.65V shuts down the chip (both channels). Driving this pin to V_{IN} or releasing this pin enables the chip, using the chip's internal soft-start. An external soft-start can be programmed by connecting a capacitor between this pin and ground.

TG1/TG2 (Pins 17, 15/Pins 20, 18): Top (PMOS) Gate Drive Output. These pins drive the gates of the external P-channel MOSFETs. These pins have an output swing from PGND to SENSE⁺.

SYNC/SSEN (Pin 18/Pin 21): Synchronization Input and Spread Spectrum Modulation Enable Input. To synchronize the LTC3776's switching frequency to an external clock

3776fa

FUNCTIONAL DIAGRAM (Controller 1)

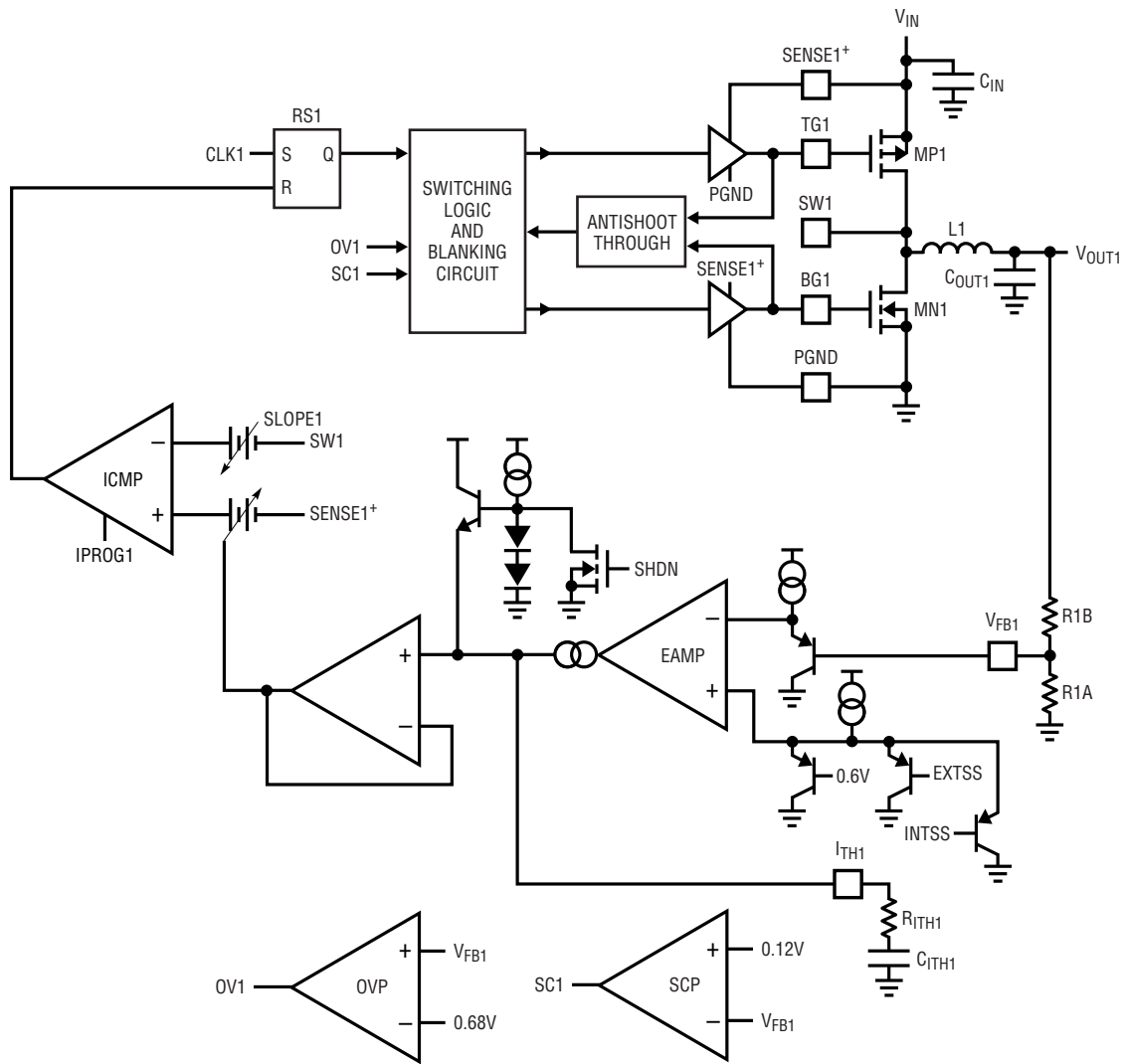

FUNCTIONAL DIAGRAM (Controller 2)

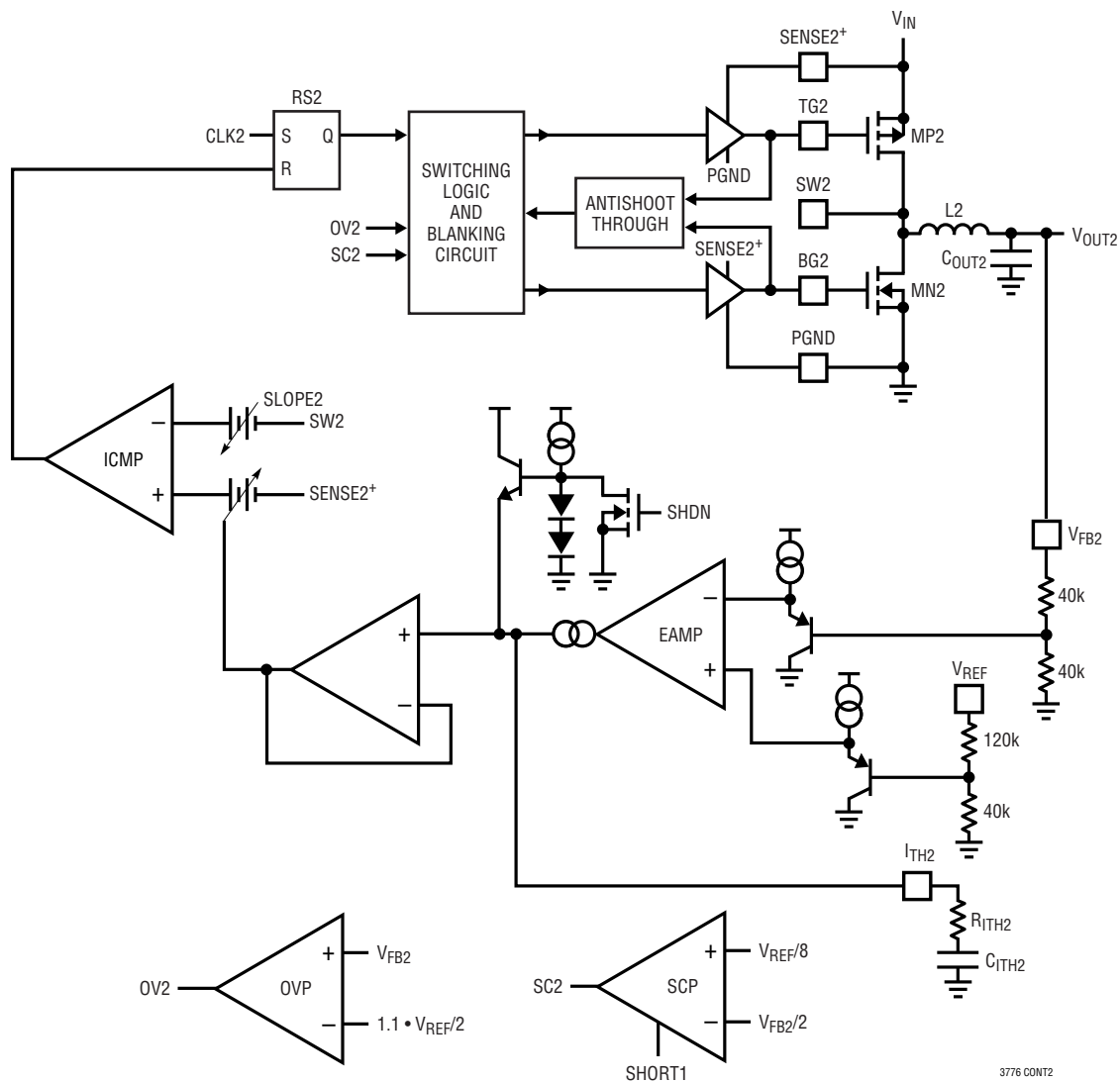

OPERATION (Refer to Functional Diagram)

Main Control Loop

The LTC3776 uses a constant frequency, current mode architecture with the two controllers operating 180 degrees out of phase. During normal operation, the top external P-channel power MOSFET is turned on when the clock for that channel sets the RS latch, and turned off when the current comparator (I_{CMP}) resets the latch. The

peak inductor current at which I_{CMP} resets the RS latch is determined by the voltage on the I_{TH} pin, which is driven by the output of the error amplifier (EAMP). The V_{FB} pin receives the output voltage feedback signal from an external resistor divider. This feedback signal is compared to a reference (either the internal 0.6V reference for controller 1 or the divided down V_{REF} pin for CH2) by the EAMP.

OPERATION (Refer to Functional Diagram)

When the load current increases, it causes a slight decrease in V_{FB} relative to the reference, which in turn causes the I_{TH} voltage to increase until the average inductor current matches the new load current. While the top P-channel MOSFET is off, the bottom N-channel MOSFET is turned on until the beginning of the next cycle.

Shutdown, Soft-Start and Tracking Start-Up (RUN/SS and TRACK Pins)

The LTC3776 is shut down by pulling the RUN/SS pin low. In shutdown, all controller functions are disabled and the chip draws only $9\mu\text{A}$. The TG outputs are held high (off) and the BG outputs low (off) in shutdown. Releasing RUN/SS allows an internal $0.7\mu\text{A}$ current source to charge up the RUN/SS pin. When the RUN/SS pin reaches 0.65V , the LTC3776's two controllers are enabled.

The start-up of V_{OUT1} is controlled by the LTC3776's internal soft-start. During soft-start, the error amplifier EAMP compares the feedback signal V_{FB1} to the internal soft-start ramp (instead of the 0.6V reference), which rises linearly from 0V to 0.6V in about 1ms . This allows the output voltage to rise smoothly from 0V to its final value, while maintaining control of the inductor current.

The 1ms soft-start time can be increased by connecting the optional external soft-start capacitor C_{SS} between the RUN/SS and SGND pins. As the RUN/SS pin continues to rise linearly from approximately 0.65V to 1.25V (being charged by the internal $0.7\mu\text{A}$ current source), the EAMP regulates the V_{FB1} proportionally linearly from 0V to 0.6V .

The start-up of V_{OUT2} is controlled by the voltage on the V_{REF} pin. Typically, V_{OUT1} is connected to the V_{REF} pin to allow the start-up of V_{OUT2} to "track" that of $1/2 V_{OUT1}$.

Note that if either V_{OUT1} or V_{OUT2} is less than 90% (lower PGOOD threshold) of its regulation point (in either a startup or short-circuit condition), then channel one's inductor current is not allowed to reverse (i.e., discontinuous operation is forced). This is to prevent a minimum on-time condition during startup.

Short-Circuit Protection

When an output is shorted to ground, the switching frequency of that controller is reduced to $1/5$ of the normal operating frequency.

The short-circuit threshold on V_{FB2} is based on the smaller of 0.12V and a fraction of the voltage on the V_{REF} pin. This also allows V_{OUT2} to start up and track V_{OUT1} more easily. Note that if V_{OUT1} is truly short-circuited ($V_{OUT1} = V_{FB1} = 0\text{V}$), then the LTC3776 will try to regulate V_{OUT2} to 0V if V_{OUT1} is connected to the V_{REF} pin.

Output Overvoltage Protection

As further protection, the overvoltage comparator (OV) guards against transient overshoots, as well as other more serious conditions that may overvoltage the output. When the feedback voltage on the V_{FB} pin has risen 13.33% above its resolution point, the external P-channel MOSFET is turned off and the N-channel MOSFET is turned on until the overvoltage is cleared.

Frequency Selection and Phase-Locked Loop (PLLLPF and SYNC/SSEN Pins)

The selection of switching frequency is a tradeoff between efficiency and component size. Low frequency operation increases efficiency by reducing MOSFET switching losses, but requires larger inductance and/or capacitance to maintain low output ripple voltage.

The switching frequency of the LTC3776's controllers can be selected using the PLLLPF pin.

If the SYNC/SSEN pin is tied to ground, the PLLLPF pin can be floated, tied to V_{IN} , or tied to SGND to select 550kHz , 750kHz , or 300kHz constant frequency operation, respectively.

A phase-locked loop (PLL) is available on the LTC3776 to synchronize the internal oscillator to an external clock source that connected to the SYNC/SSEN pin. In this case, a series RC should be connected between the PLLLPF pin and SGND to serve as the PLL's loop filter. The LTC3776

OPERATION (Refer to Functional Diagram)

phase detector adjusts the voltage on the PLLPF pin to align the turn-on of controller 1's external P-channel MOSFET to the rising edge of the synchronizing signal. Thus, the turn-on of controller 2's external P-channel MOSFET is 180 degrees out of phase with the rising edge of the external clock source.

The typical capture range of the LTC3776's phase-locked loop is from approximately 200kHz to 1MHz, with a guarantee over all process variations and temperature to be between 250kHz and 850kHz. In other words, the LTC3776's PLL is guaranteed to lock to an external clock source whose frequency is between 250kHz and 850kHz. Alternatively, the SYNC/SSEN pin may be tied to V_{IN} to

enable spread spectrum operation (see Spread Spectrum Operation section).

Spread Spectrum Operation

Switching regulators can be particularly troublesome in applications where electromagnetic interference (EMI) is a concern. Switching regulators operate on a cycle-by-cycle basis to transfer power to an output. In most cases, the frequency of operation is either fixed or is a constant based on the output load. This method of conversion creates large components of noise at the frequency of operation (fundamental) and multiples of the operating frequency (harmonics). Figures 1a and 1b depict the

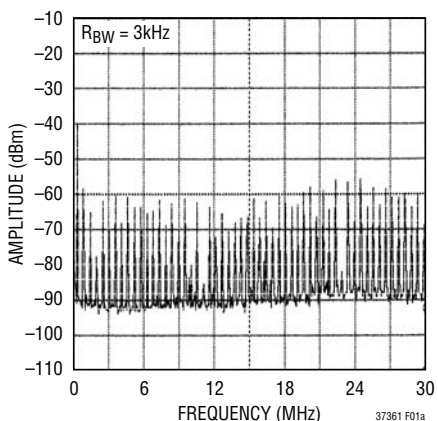

Figure 1a. Output Noise Spectrum of Conventional Buck Switching Converter (LTC3776 with Spread Spectrum Disabled) Showing Fundamental and Harmonic Frequencies

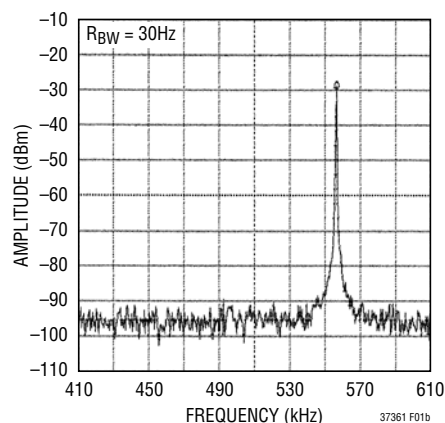

Figure 1b. Zoom-In of Fundamental Frequency of Conventional Buck Switching Converter

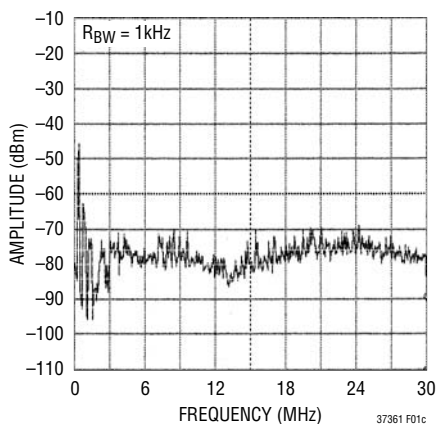

Figure 1c. Output Noise Spectrum of the LTC3776 Spread Spectrum Buck Switching Converter. Note the Reduction in Fundamental and Harmonic Peak Spectral Amplitude Compared to Figure 1a.

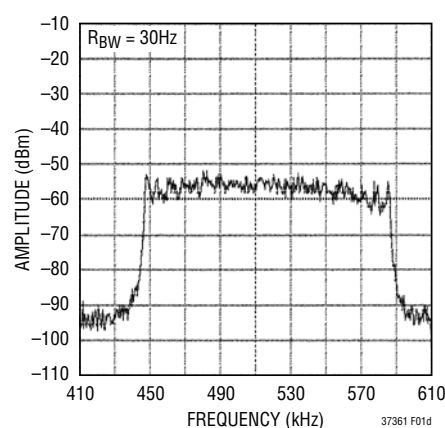

Figure 1d. Zoom-In of Fundamental Frequency of the LTC3776 Spread Spectrum Buck Switching Converter. Note the >20dB Reduction in Peak Amplitude and Spreading of the Frequency Spectrum (Between Approximately 450kHz and 580kHz) Compared to Figure 1b.

OPERATION (Refer to Functional Diagram)

output noise spectrum of a conventional buck switching converter (1/2 of LTC3776 with spread spectrum operation disabled) with $V_{IN} = 5V$, $V_{OUT} = 2.5V$ and $I_{OUT} = 2A$.

Unlike conventional buck converters, the LTC3776's internal oscillator can be selected to produce a clock pulse whose frequency is randomly varied between 450kHz and 580kHz by tying the SYNC/SEN pin to V_{IN} . This has the benefit of spreading the switching noise over a range of frequencies, thus significantly reducing the peak noise. Figures 1c and 1d show the output noise spectrum of the LTC3776 (with spread spectrum operation enabled) with $V_{IN} = 5V$, $V_{OUT} = 2.5V$ and $I_{OUT} = 1A$. Note the significant reduction in peak output noise (>20dBm).

Dropout Operation

When the input supply voltage (V_{IN}) decreases towards the output voltage, the rate of change of the inductor current while the external P-channel MOSFET is on (ON cycle) decreases. This reduction means that the P-channel MOSFET will remain on for more than one oscillator cycle if the inductor current has not ramped up to the threshold set by the EAMP on the I_{TH} pin. Further reduction in the input supply voltage will eventually cause the P-channel MOSFET to be turned on 100%; i.e., DC. The output voltage will then be determined by the input voltage minus the voltage drop across the P-channel MOSFET and the inductor.

Undervoltage Lockout

To prevent operation of the external MOSFETs below safe input voltage levels, an undervoltage lockout is incorporated in the LTC3776. When the input supply voltage (V_{IN}) drops below 2.3V, the external P- and N-channel MOSFETs and all internal circuitry are turned off except for the undervoltage block, which draws only a few microamperes.

Peak Current Sense Voltage Selection and Slope Compensation (IPRG1 and IPRG2 Pins)

When controller 1 is operating below 20% duty cycle, the peak current sense voltage (between the SENSE1+ and SW1 pins) allowed across the external P-channel MOSFET is determined by:

$$\Delta V_{SENSE(MAX)1} = \frac{A1(V_{ITH1} - 0.7V)}{10}$$

where A1 is a constant determined by the state of the IPRG pins. Floating the IPRG1 pin selects $A1 = 1$; tying IPRG to V_{IN} selects $A1 = 5/3$; tying IPRG1 to SGND selects $A1 = 2/3$. The maximum value of V_{ITH1} is typically about 1.98V, so the maximum sense voltage allowed across the external P-channel MOSFET is 125mV, 85mV or 204mV for the three respective states of the IPRG1 pin.

When controller 2 is operating below 20% duty cycle, the peak current sense voltage (between the SENSE2+ and SW2 pins) allowed across the external P-channel MOSFET is determined by:

$$\Delta V_{SENSE(MAX)} = \frac{A2(V_{ITH2} - 1.3V)}{4.6}, V_{ITH2} \geq 1.3V$$

$$\Delta V_{SENSE(MAX)} = \frac{A2(V_{ITH2} - 1.3V)}{5.4}, V_{ITH2} < 1.3V$$

where A is a constant determined by the state of the IPRG pins. Floating the IPRG2 pin selects $A2 = 1$; tying IPRG2 to V_{IN} selects $A2 = 5/3$; tying IPRG2 to SGND selects $A2 = 2/3$. The maximum value of V_{ITH2} is typically about 1.98V, so the maximum sense voltage allowed across the external P-channel MOSFET is 147mV, 100mV or 245mV for the three respective states of the IPRG2 pin. The minimum value of V_{ITH2} is typically about 0.7V, so the minimum (most negative) peak sense voltage is -112mV, -75mV or -188mV, respectively.

However, once the controller's duty cycle exceeds 20%, slope compensation begins and effectively reduces the peak sense voltage by a scale factor given by the curve in Figure 2.

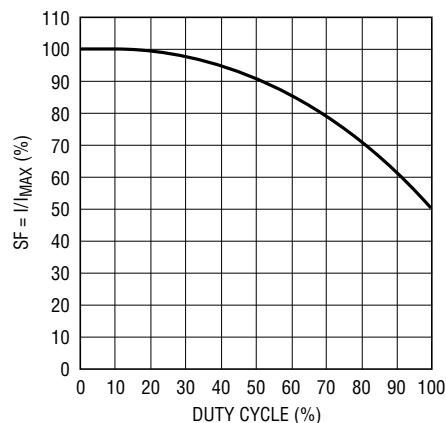

Figure 2. Maximum Peak Current vs Duty Cycle

3776 F02

3776fa

OPERATION (Refer to Functional Diagram)

The peak inductor current is determined by the peak sense voltage and the on-resistance of the external P-channel MOSFET:

$$I_{PK} = \frac{\Delta V_{SENSE(MAX)}}{R_{DS(ON)}}$$

Power Good (PGOOD) Pin

A window comparator monitors both feedback voltages and the open-drain PGOOD output pin is pulled low when either or both feedback voltages are not within $\pm 10\%$ of their reference voltages. PGOOD is low when the LTC3776 is shut down or in undervoltage lockout.

2-Phase Operation

Why the need for 2-phase operation? Until recently, constant frequency dual switching regulators operated both controllers in phase (i.e., single phase operation). This means that both topside MOSFETs (P-channel) are turned on at the same time, causing current pulses of up to twice the amplitude of those from a single regulator to be drawn from the input capacitor. These large amplitude pulses increase the total RMS current flowing in the input capacitor, requiring the use of larger and more expensive input capacitors, and increase both EMI and power losses in the input capacitor and input power supply.

With 2-phase operation, the two controllers of the LTC3776 are operated 180 degrees out of phase. This effectively interleaves the current pulses coming from the topside MOSFET switches, greatly reducing the time where they overlap and add together. The result is a significant reduction in the total RMS current, which in turn allows the use of smaller, less expensive input capacitors, reduces shielding requirements for EMI and improves real world operating efficiency.

Figure 3 shows qualitatively example waveforms for a single phase dual controller versus a 2-phase LTC3776 system. In this case, 2.5V and 1.8V outputs, each drawing a load current of 2A, are derived from a 7V (e.g., a 2-cell Li-Ion battery) input supply. In this example, 2-phase operation would reduce the RMS input capacitor current from $1.79A_{RMS}$ to $0.91A_{RMS}$. While this is an impressive reduction by itself, remember that power losses are

proportional to I_{RMS}^2 , meaning that actual power wasted is reduced by a factor of 3.86.

The reduced input ripple current also means that less power is lost in the input power path, which could include batteries, switches, trace/connector resistances, and protection circuitry. Improvements in both conducted and radiated EMI also directly accrue as a result of the reduced RMS input current and voltage. Significant cost and board footprint savings are also realized by being able to use smaller, less expensive, lower RMS current-rated input capacitors.

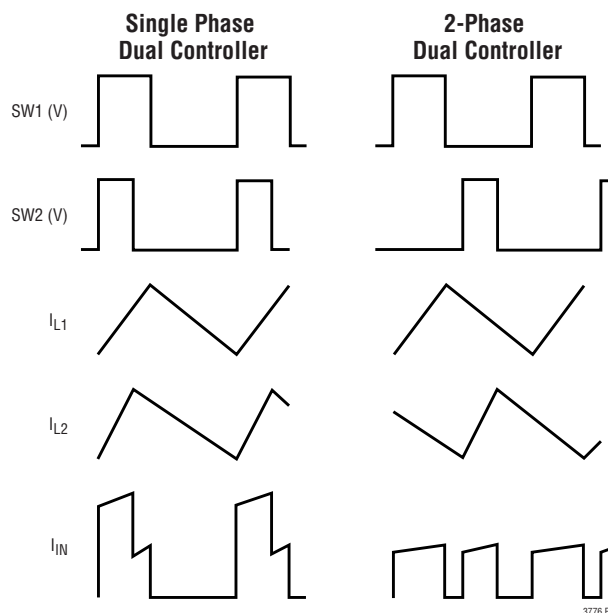

Figure 3. Example Waveforms for a Single Phase Dual Controller vs the 2-Phase LTC3776

Of course, the improvement afforded by 2-phase operation is a function of the relative duty cycles of the two controllers, which in turn are dependent upon the input supply voltage. Figure 4 depicts how the RMS input current varies for single phase and 2-phase dual controllers with 2.5V and 1.8V outputs over a wide input voltage range.

It can be readily seen that the advantages of 2-phase operation are not limited to a narrow operating range, but in fact extend over a wide region. A good rule of thumb for most applications is that 2-phase operation will reduce the input capacitor requirement to that for just one channel operating at maximum current and 50% duty cycle.

APPLICATIONS INFORMATION

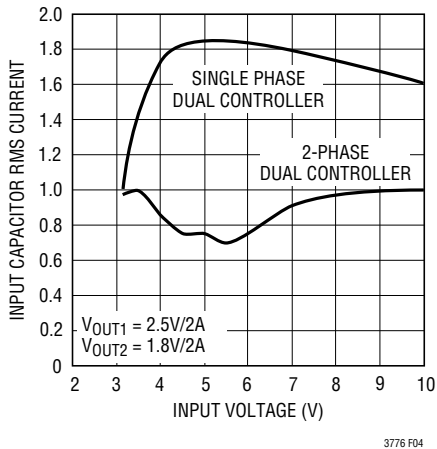

Figure 4. RMS Input Current Comparison

The typical LTC3776 application circuit is shown in Figure 11. External component selection for each of the LTC3776's controllers is driven by the load requirement and begins with the selection of the inductor (L) and the power MOSFETs (MP and MN).

Power MOSFET Selection

Each of the LTC3776's two controllers requires two external power MOSFETs: a P-channel MOSFET for the topside (main) switch and an N-channel MOSFET for the bottom (synchronous) switch. Important parameters for the power MOSFETs are the breakdown voltage $V_{BR(DSS)}$, threshold voltage $V_{GS(TH)}$, on-resistance $R_{DS(ON)}$, reverse transfer capacitance C_{RSS} , turn-off delay $t_{D(OFF)}$ and the total gate charge Q_G .

The gate drive voltage is the input supply voltage. Since the LTC3776 is designed for operation down to low input voltages, a sublogic level MOSFET ($R_{DS(ON)}$ guaranteed at $V_{GS} = 2.5V$) is required for applications that work close to this voltage. When these MOSFETs are used, make sure that the input supply to the LTC3776 is less than the absolute maximum MOSFET V_{GS} rating, which is typically 8V.

The P-channel MOSFET's on-resistance is chosen based on the required load current. The maximum average output load current $I_{OUT(MAX)}$ is equal to the peak inductor current minus half the peak-to-peak ripple current I_{RIPPLE} . The LTC3776's current comparator monitors the drain-to-source voltage V_{DS} of the P-channel MOSFET, which is sensed between the SENSE⁺ and SW pins. The peak

inductor current is limited by the current threshold, set by the voltage on the I_{TH} pin of the current comparator. The voltage on the I_{TH} pin is internally clamped, which limits the maximum current sense threshold $\Delta V_{SENSE(MAX)}$.

The output current that the LTC3776 can provide is given by:

$$I_{OUT(MAX)} = \frac{\Delta V_{SENSE(MAX)}}{R_{DS(ON)}} - \frac{I_{RIPPLE}}{2}$$

A reasonable starting point is setting ripple current I_{RIPPLE} to be 40% of $I_{OUT(MAX)}$. Rearranging the above equation yields:

$$R_{DS(ON)(MAX)} = \frac{5}{6} \cdot \frac{\Delta V_{SENSE(MAX)}}{I_{OUT(MAX)}}$$

for Duty Cycle < 20%.

However, for operation above 20% duty cycle, slope compensation has to be taken into consideration to select the appropriate value of $R_{DS(ON)}$ to provide the required amount of load current:

$$R_{DS(ON)(MAX)} = \frac{5}{6} \cdot SF \cdot \frac{\Delta V_{SENSE(MAX)}}{I_{OUT(MAX)}}$$

where SF is a scale factor whose value is obtained from the curve in Figure 2.

These must be further derated to take into account the significant variation in on-resistance with temperature. The following equation is a good guide for determining the required $R_{DS(ON)MAX}$ at 25°C (manufacturer's specification), allowing some margin for variations in the LTC3776 and external component values:

$$R_{DS(ON)(MAX)} = \frac{5}{6} \cdot 0.9 \cdot SF \cdot \frac{\Delta V_{SENSE(MAX)}}{I_{OUT(MAX)} \cdot \rho_T}$$

The ρ_T is a normalizing term accounting for the temperature variation in on-resistance, which is typically about 0.4%/°C, as shown in Figure 5. Junction to case temperature T_{JC} is about 10°C in most applications. For a maximum ambient temperature of 70°C, using $\rho_{80°C} \sim 1.3$ in the above equation is a reasonable choice.

APPLICATIONS INFORMATION

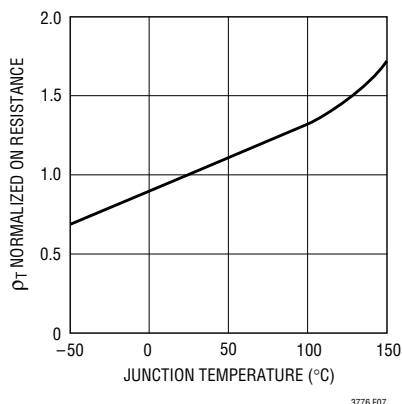

Figure 5. $R_{DS(ON)}$ vs Temperature

The power dissipated in the top and bottom MOSFETs strongly depends on their respective duty cycles and load current. When the LTC3776 is operating in continuous mode, the duty cycles for the MOSFETs are:

$$\text{Top P-Channel Duty Cycle} = \frac{V_{OUT}}{V_{IN}}$$

$$\text{Bottom N-Channel Duty Cycle} = \frac{V_{IN} - V_{OUT}}{V_{IN}}$$

The MOSFET power dissipations at maximum output current are:

$$P_{TOP} = \frac{V_{OUT}}{V_{IN}} \cdot I_{OUT(MAX)}^2 \cdot \rho_T \cdot R_{DS(ON)} + 2 \cdot V_{IN}^2 \cdot I_{OUT(MAX)} \cdot C_{RSS} \cdot f_{OSC}$$

$$P_{BOT} = \frac{V_{IN} - V_{OUT}}{V_{IN}} \cdot I_{OUT(MAX)}^2 \cdot \rho_T \cdot R_{DS(ON)}$$

Both MOSFETs have I^2R losses and the P_{TOP} equation includes an additional term for transition losses, which are largest at high input voltages. The bottom MOSFET losses are greatest at high input voltage or during a short circuit when the bottom duty cycle is nearly 100%.

The LTC3776 utilizes a nonoverlapping, antishoot-through gate drive control scheme to ensure that the P- and N-channel MOSFETs are not turned on at the same time. To function properly, the control scheme requires that the MOSFETs used are intended for DC/DC switching applications. Many power MOSFETs, particularly P-channel MOSFETs, are intended to be used as static switches and therefore are slow to turn on or off.

Reasonable starting criteria for selecting the P-channel MOSFET are that it must typically have a gate charge (Q_G) less than 25nC to 30nC (at 4.5V_{GS}) and a turn-off delay ($t_{D(OFF)}$) of less than approximately 140ns. However, due to differences in test and specification methods of various MOSFET manufacturers, and in the variations in Q_G and $t_{D(OFF)}$ with gate drive (V_{IN}) voltage, the P-channel MOSFET ultimately should be evaluated in the actual LTC3776 application circuit to ensure proper operation.

Shoot-through between the P-channel and N-channel MOSFETs can most easily be spotted by monitoring the input supply current. As the input supply voltage increases, if the input supply current increases dramatically, then the likely cause is shoot-through. Note that some MOSFETs that do not work well at high input voltages (e.g., $V_{IN} > 5V$) may work fine at lower voltages (e.g., 3.3V). Table 1 shows a selection of P-channel MOSFETs from different manufacturers that are known to work well in LTC3776 applications.

Selecting the N-channel MOSFET is typically easier, since for a given $R_{DS(ON)}$, the gate charge and turn-on and turn-off delays are much smaller than for a P-channel MOSFET.

Table 1. Selected P-Channel MOSFETs Suitable for LTC3776 Applications

PART NUMBER	MANUFACTURER	TYPE	PACKAGE
Si7540DP	Siliconix	Complementary P/N	PowerPak SO-8
Si9801DY	Siliconix	Complementary P/N	SO-8
FDW2520C	Fairchild	Complementary P/N	TSSOP-8
FDW2521C	Fairchild	Complementary P/N	TSSOP-8
Si3447BDV	Siliconix	Single P	TSOP-6
Si9803DY	Siliconix	Single P	SO-8
FDC602P	Fairchild	Single P	TSOP-6
FDC606P	Fairchild	Single P	TSOP-6
FDC638P	Fairchild	Single P	TSOP-6
FDW2502P	Fairchild	Dual P	TSSOP-8
FDS6875	Fairchild	Dual P	SO-8
HAT1054R	Hitachi	Dual P	SO-8
NTMD6P02R2-D	On Semi	Dual P	SO-8

APPLICATIONS INFORMATION

Operating Frequency and Synchronization

The choice of operating frequency, f_{OSC} , is a trade-off between efficiency and component size. Low frequency operation improves efficiency by reducing MOSFET switching losses, both gate charge loss and transition loss. However, lower frequency operation requires more inductance for a given amount of ripple current.

The internal oscillator for each of the LTC3776's controllers runs at a nominal 550kHz frequency when the PLLLPF pin is left floating and the SYNC/SSEN pin is tied to GND. Pulling the PLLLPF to V_{IN} selects 750kHz operation; pulling the PLLLPF to GND selects 300kHz operation.

Alternatively, the LTC3776 will phase-lock to a clock signal applied to the SYNC/SSEN pin with a frequency between 250kHz and 850kHz (see Phase-Locked Loop and Frequency Synchronization).

When spread spectrum operation is enabled (SYNC/SSEN = V_{IN}), the frequency of the LTC3776 is randomly varied over the range of frequencies between 450kHz and 580kHz. In this case, a capacitor (1nF to 4.7nF) should be connected between the FREQ pin and SGND to smooth out the changes in frequency. This not only provides a smoother frequency spectrum but also ensures that the switching regulator remains stable by preventing abrupt changes in frequency. A value of 2200pF is suitable in most applications.

Inductor Value Calculation

Given the desired input and output voltages, the inductor value and operating frequency f_{OSC} directly determine the inductor's peak-to-peak ripple current:

$$I_{RIPPLE} = \frac{V_{OUT}}{V_{IN}} \left(\frac{V_{IN} - V_{OUT}}{f_{OSC} \cdot L} \right)$$

Lower ripple current reduces core losses in the inductor, ESR losses in the output capacitors, and output voltage ripple. Thus, highest efficiency operation is obtained at low frequency with a small ripple current. Achieving this, however, requires a large inductor.

A reasonable starting point is to choose a ripple current that is about 40% of $I_{OUT(MAX)}$. Note that the largest ripple

current occurs at the highest input voltage. To guarantee that ripple current does not exceed a specified maximum, the inductor should be chosen according to:

$$L \geq \frac{V_{IN} - V_{OUT}}{f_{OSC} \cdot I_{RIPPLE}} \cdot \frac{V_{OUT}}{V_{IN}}$$

Inductor Core Selection

Once the inductance value is determined, the type of inductor must be selected. Actual core loss is independent of core size for a fixed inductor value, but it is very dependent on inductance selected. As inductance increases, core losses go down. Unfortunately, increased inductance requires more turns of wire and therefore copper losses will increase.

Ferrite designs have very low core loss and are preferred at high switching frequencies, so design goals can concentrate on copper loss and preventing saturation. Ferrite core material saturates "hard," which means that inductance collapses abruptly when the peak design current is exceeded. This results in an abrupt increase in inductor ripple current and consequent output voltage ripple. Do not allow the core to saturate!

Different core materials and shapes will change the size/current and price/current relationship of an inductor. Toroid or shielded pot cores in ferrite or permalloy materials are small and don't radiate much energy, but generally cost more than powdered iron core inductors with similar characteristics. The choice of which style inductor to use mainly depends on the price vs size requirements and any radiated field/EMI requirements. New designs for surface mount inductors are available from Coiltronics, Coilcraft, Toko and Sumida.

Schottky Diode Selection (Optional)

The Schottky diodes D1 and D2 in Figure 16 conduct current during the dead time between the conduction of the power MOSFETs. This prevents the body diode of the bottom N-channel MOSFET from turning on and storing charge during the dead time, which could cost as much as 1% in efficiency. A 1A Schottky diode is generally a good

Kool M μ is a registered trademark of Magnetics, Inc.

APPLICATIONS INFORMATION

size for most LTC3776 applications, since it conducts a relatively small average current. Larger diodes result in additional transition losses due to their larger junction capacitance. This diode may be omitted if the efficiency loss can be tolerated.

C_{IN} and C_{OUT} Selection

The selection of C_{IN} is simplified by the 2-phase architecture and its impact on the worst-case RMS current drawn through the input network (battery/fuse/capacitor). It can be shown that the worst-case capacitor RMS current occurs when only one controller is operating. The controller with the highest $(V_{OUT})(I_{OUT})$ product needs to be used in the formula below to determine the maximum RMS capacitor current requirement. Increasing the output current drawn from the other controller will actually decrease the input RMS ripple current from its maximum value. The out-of-phase technique typically reduces the input capacitor's RMS ripple current by a factor of 30% to 70% when compared to a single phase power supply solution.

In continuous mode, the source current of the P-channel MOSFET is a square wave of duty cycle $(V_{OUT})/(V_{IN})$. To prevent large voltage transients, a low ESR capacitor sized for the maximum RMS current of one channel must be used. The maximum RMS capacitor current is given by:

$$C_{IN} \text{ Required } I_{RMS} \approx \frac{I_{MAX}}{V_{IN}} [(V_{OUT})(V_{IN} - V_{OUT})]^{1/2}$$

This formula has a maximum at $V_{IN} = 2V_{OUT}$, where $I_{RMS} = I_{OUT}/2$. This simple worst-case condition is commonly used for design because even significant deviations do not offer much relief. Note that capacitor manufacturers' ripple current ratings are often based on only 2000 hours of life. This makes it advisable to further derate the capacitor, or to choose a capacitor rated at a higher temperature than required. Several capacitors may be paralleled to meet size or height requirements in the design. Due to the high operating frequency of the LTC3776, ceramic capacitors can also be used for C_{IN} . Always consult the manufacturer if there is any question.

The benefit of the LTC3776 2-phase operation can be calculated by using the equation above for the higher power

controller and then calculating the loss that would have resulted if both controller channels switched on at the same time. The total RMS power lost is lower when both controllers are operating due to the reduced overlap of current pulses required through the input capacitor's ESR. This is why the input capacitor's requirement calculated above for the worst-case controller is adequate for the dual controller design. Also, the input protection fuse resistance, battery resistance, and PC board trace resistance losses are also reduced due to the reduced peak currents in a 2-phase system. The overall benefit of a multiphase design will only be fully realized when the source impedance of the power supply/battery is included in the efficiency testing. The sources of the P-channel MOSFETs should be placed within 1cm of each other and share a common $C_{IN}(s)$. Separating the sources and C_{IN} may produce undesirable voltage and current resonances at V_{IN} .

A small (0.1 μ F to 1 μ F) bypass capacitor between the chip V_{IN} pin and ground, placed close to the LTC3776, is also suggested. A 10 Ω resistor placed between C_{IN} (C1) and the V_{IN} pin provides further isolation between the two channels.

The selection of C_{OUT} is driven by the effective series resistance (ESR). Typically, once the ESR requirement is satisfied, the capacitance is adequate for filtering. The output ripple (ΔV_{OUT}) is approximated by:

$$\Delta V_{OUT} \approx I_{RIPPLE} \left(ESR + \frac{1}{8fC_{OUT}} \right)$$

where f is the operating frequency, C_{OUT} is the output capacitance and I_{RIPPLE} is the ripple current in the inductor. The output ripple is highest at maximum input voltage since I_{RIPPLE} increases with input voltage.

Setting Output Voltage

The LTC3776's channel 1 output voltage is set by an external feedback resistor divider carefully placed across the output, as shown in Figure 6. The regulated output voltage is determined by:

$$V_{OUT1} = 0.6V \cdot \left(1 + \frac{R_B}{R_A} \right)$$

APPLICATIONS INFORMATION

Channel 2's output voltage is set to $1/2 V_{REF}$ by connecting the V_{FB2} pin to V_{OUT2} . To improve the frequency response, a feed-forward capacitor, C_{FF} , may be used. Great care should be taken to route the V_{FB} line away from noise sources, such as the inductor or the SW line.

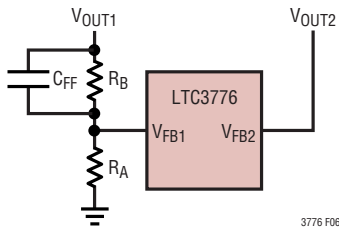

Figure 6. Setting Output Voltage

Run/Soft Start Function

The RUN/SS pin is a dual purpose pin that provides the optional external soft-start function and a means to shut down the LTC3776.

Pulling the RUN/SS pin below 0.65V puts the LTC3776 into a low quiescent current shutdown mode ($I_Q = 9\mu A$). If RUN/SS has been pulled all the way to ground, there will be a delay before the LTC3776 comes out of shutdown and is given by:

$$t_{DELAY} = 0.65V \cdot \frac{C_{SS}}{0.7\mu A} = 0.93s/\mu F \cdot C_{SS}$$

This pin can be driven directly from logic as shown in Figure 7. Diode D1 in Figure 7 reduces the start delay but allows C_{SS} to ramp up slowly providing the soft-start function. This diode (and capacitor) can be deleted if the external soft-start is not needed.

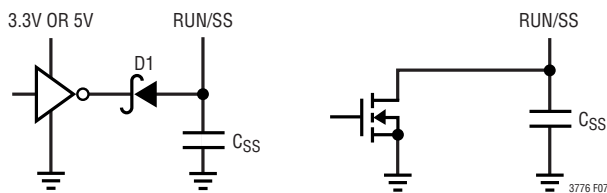

Figure 7. RUN/SS Pin Interfacing

During soft-start, the start-up of V_{OUT1} is controlled by slowly ramping the positive reference to the error amplifier from 0V to 0.6V, allowing V_{OUT1} to rise smoothly from 0V to its final value. The default internal soft-start time is 1ms. This can be increased by placing a capacitor between the RUN/SS pin and SGND. In this case, the soft-start time will be approximately:

$$t_{SS1} = C_{SS} \cdot \frac{600mV}{0.7\mu A}$$

V_{REF} Pin

The regulation of V_{OUT2} is controlled by the voltage on the V_{REF} pin. Normally this pin is used in DDR memory termination applications so that V_{OUT2} tracks $1/2 V_{OUT1}$ as shown in Figure 8.

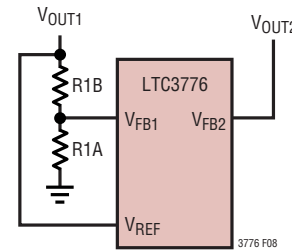

Figure 8. Using the V_{REF} Pin (V_{OUT2} is Regulated to $1/2 V_{REF} = 1/2 V_{OUT1}$)

Phase-Locked Loop and Frequency Synchronization

The LTC3776 has a phase-locked loop (PLL) comprised of an internal voltage-controlled oscillator (VCO) and a phase detector. This allows the turn-on of the external P-channel MOSFET of controller 1 to be locked to the rising edge of an external clock signal applied to the SYNC/SSEN pin. The turn-on of controller 2's external P-channel MOSFET is thus 180 degrees out of phase with the external clock. The phase detector is an edge sensitive digital type that provides zero degrees phase shift between the external and internal oscillators. This type of phase detector does not exhibit false lock to harmonics of the external clock.

The output of the phase detector is a pair of complementary current sources that charge or discharge the external filter network connected to the PLLPF pin. The relationship between the voltage on the PLLPF pin and operating

3776fa

APPLICATIONS INFORMATION

frequency, when there is a clock signal applied to SYNC/SSEN, is shown in Figure 9 and specified in the Electrical Characteristics table. Note that the LTC3776 can only be synchronized to an external clock whose frequency is within range of the LTC3776's internal VCO, which is nominally 200kHz to 1MHz. This is guaranteed, over temperature and process variations, to be between 250kHz and 850kHz. A simplified block diagram is shown in Figure 10.

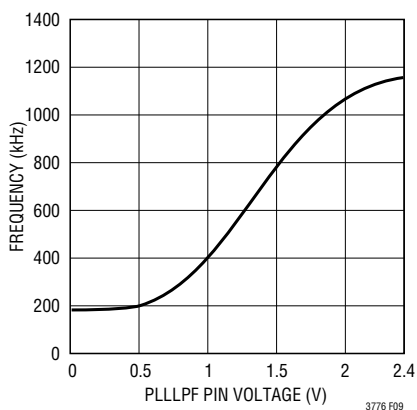

Figure 9. Relationship Between Oscillator Frequency and Voltage at the PLLPF Pin When Synchronizing to an External Clock

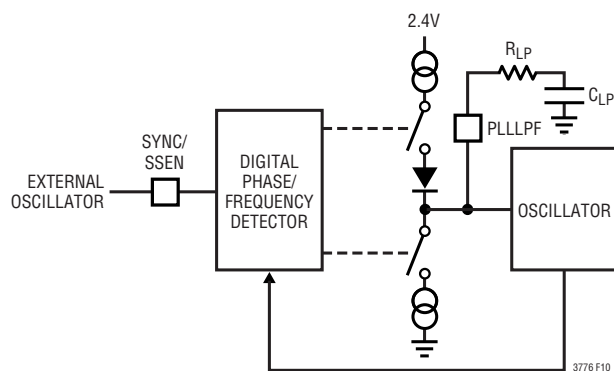

Figure 10. Phase-Locked Loop Block Diagram

If the external clock frequency is greater than the internal oscillator's frequency, f_{OSC} , then current is sourced continuously from the phase detector output, pulling up the PLLPF pin. When the external clock frequency is less than f_{OSC} , current is sunk continuously, pulling down the PLLPF pin. If the external and internal frequencies are the same but exhibit a phase difference, the current sources turn on for an amount of time corresponding to the phase difference. The voltage on the PLLPF pin is adjusted until the phase and frequency of the internal and external

oscillators are identical. At the stable operating point, the phase detector output is high impedance and the filter capacitor C_{LP} holds the voltage.

The loop filter components, C_{LP} and R_{LP} , smooth out the current pulses from the phase detector and provide a stable input to the voltage-controlled oscillator. The filter components C_{LP} and R_{LP} determine how fast the loop acquires lock. Typically $R_{LP} = 10k$ and C_{LP} is 2200pF to 0.01 μ F.

Typically, the external clock (on SYNC/SSEN pin) input high threshold is 1.6V, while the input low threshold is 1.2V.

Table 2 summarizes the different states in which the PLLPF pin can be used.

Table 2

PLLPF PIN	SYNC/SSEN PIN	FREQUENCY
0V	GND	300kHz
Floating	GND	550kHz
V_{IN}	GND	750kHz
RC Loop Filter	Clock Signal	Phase-Locked to External Clock
Capacitor to GND	V_{IN}	Spread Spectrum Operation 450kHz to 550kHz

Low Supply Operation

Although the LTC3776 can function down to below 2.4V, the maximum allowable output current is reduced as V_{IN} decreases below 3V. Figure 11 shows the amount of change as the supply is reduced down to 2.4V. Also shown is the effect on V_{REF} .

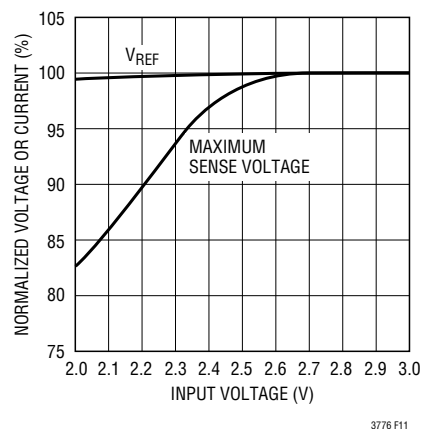

Figure 11. Line Regulation of V_{REF} and Maximum Sense Voltage for Low Input Supply

APPLICATIONS INFORMATION

Minimum On-Time Considerations

Minimum on-time, $t_{ON(MIN)}$, is the smallest amount of time in which the LTC3776 is capable of turning the top P-channel MOSFET on and then off. It is determined by internal timing delays and the gate charge required to turn on the top MOSFET. Low duty cycle and high frequency applications may approach the minimum on-time limit and care should be taken to ensure that:

$$t_{ON(MIN)} < \frac{V_{OUT}}{f_{OSC} \cdot V_{IN}}$$

If the duty cycle falls below what can be accommodated by the minimum on-time, the LTC3776 will regulate by overvoltage protection. The minimum on-time for the LTC3776 is typically about 200ns. However, as the peak sense voltage ($I_{L(PEAK)} \cdot R_{DS(ON)}$) decreases, the minimum on-time gradually increases up to about 250ns.

Efficiency Considerations

The efficiency of a switching regulator is equal to the output power divided by the input power times 100%. It is often useful to analyze individual losses to determine what is limiting efficiency and which change would produce the most improvement. Efficiency can be expressed as:

$$\text{Efficiency} = 100\% - (L1 + L2 + L3 + \dots)$$

where L1, L2, etc. are the individual losses as a percentage of input power.

Although all dissipative elements in the circuit produce losses, five main sources usually account for most of the losses in LTC3776 circuits: 1) LTC3776 DC bias current, 2) MOSFET gate charge current, 3) I^2R losses, and 4) transition losses.

- 1) The V_{IN} (pin) current is the DC supply current, given in the electrical characteristics, excluding MOSFET driver currents. V_{IN} current results in a small loss that increases with V_{IN} .
- 2) MOSFET gate charge current results from switching the gate capacitance of the power MOSFETs. Each time a MOSFET gate is switched from low to high to low again, a packet of charge dQ moves from SENSE⁺ to ground. The resulting dQ/dt is a current out of SENSE⁺, which is

typically much larger than the DC supply current. In continuous mode, $I_{GATECHG} = f \cdot Q_P$.

- 3) I^2R losses are calculated from the DC resistances of the MOSFETs and inductor. In continuous mode, the average output current flows through L but is “chopped” between the top P-channel MOSFET and the bottom N-channel MOSFET. The MOSFET $R_{DS(ON)}$ s multiplied by duty cycle can be summed with the resistance of L to obtain I^2R losses.
- 4) Transition losses apply to the top external P-channel MOSFET and increase with higher operating frequencies and input voltages. Transition losses can be estimated from:

$$\text{Transition Loss} = 2 (V_{IN})^2 I_{O(MAX)} C_{RSS}(f)$$

Other losses, including C_{IN} and C_{OUT} ESR dissipative losses and inductor core losses, generally account for less than 2% total additional loss.

Checking Transient Response

The regulator loop response can be checked by looking at the load transient response. Switching regulators take several cycles to respond to a step in load current. When a load step occurs, V_{OUT} immediately shifts by an amount equal to $(\Delta I_{LOAD})(ESR)$, where ESR is the effective series resistance of C_{OUT} . ΔI_{LOAD} also begins to charge or discharge C_{OUT} , which generates a feedback error signal. The regulator loop then returns V_{OUT} to its steady-state value. During this recovery time, V_{OUT} can be monitored for overshoot or ringing. OPTI-LOOP compensation allows the transient response to be optimized over a wide range of output capacitance and ESR values.

The I_{TH} series R_C - C_C filter (see Functional Diagram) sets the dominant pole-zero loop compensation. The I_{TH} external components shown in the Typical Application on the front page of this data sheet will provide an adequate starting point for most applications. The values can be modified slightly (from 0.2 to 5 times their suggested values) to optimize transient response once the final PC layout is done and the particular output capacitor type and value have been determined. The output capacitors need to be decided upon because the various types and values

APPLICATIONS INFORMATION

determine the loop feedback factor gain and phase. An output current pulse of 20% to 100% of full load current having a rise time of $1\mu\text{s}$ to $10\mu\text{s}$ will produce output voltage and I_{TH} pin waveforms that will give a sense of the overall loop stability. The gain of the loop will be increased by increasing R_C , and the bandwidth of the loop will be increased by decreasing C_C . The output voltage settling behavior is related to the stability of the closed-loop system and will demonstrate the actual overall supply performance. For a detailed explanation of optimizing the compensation components, including a review of control loop theory, refer to Application Note 76.

A second, more severe transient is caused by switching in loads with large ($>1\mu\text{F}$) supply bypass capacitors. The discharged bypass capacitors are effectively put in parallel with C_{OUT} , causing a rapid drop in V_{OUT} . No regulator can deliver enough current to prevent this problem if the load switch resistance is low and it is driven quickly. The only solution is to limit the rise time of the switch drive so that the load rise time is limited to approximately $(25)(C_{\text{LOAD}})$. Thus a $10\mu\text{F}$ capacitor would require a $250\mu\text{s}$ rise time, limiting the charging current to about 200mA.

PC Board Layout Checklist

When laying out the printed circuit board, the following checklist should be used to ensure proper operation of the LTC3776. These items are illustrated in the layout diagram of Figure 12. Figure 13 depicts the current waveforms present in the various branches of the 2-phase dual regulator.

1) The power loop (input capacitor, MOSFETs, inductor, output capacitor) of each channel should be as small as possible and isolated as much as possible from the power loop of the other channel. Ideally, the drains of the P- and N-channel FETs should be connected close to one another with an input capacitor placed across the FET sources (from the P-channel source to the N-channel source) right at the FETs. It is better to have two separate, smaller valued input capacitors (e.g., two $10\mu\text{F}$ —one for each channel) than it is to have a single larger valued capacitor (e.g., $22\mu\text{F}$) that the channels share with a common connection.

2) The signal and power grounds should be kept separate. The signal ground consists of the feedback resistor dividers, I_{TH} compensation networks and the SGND pin.

The power grounds consist of the (–) terminal of the input and output capacitors and the source of the N-channel MOSFET. Each channel should have its own power ground for its power loop (as described in (1) above). The power grounds for the two channels should connect together at a common point. It is most important to keep the ground paths with high switching currents away from each other.

The PGND pins on the LTC3776 IC should be shorted together and connected to the common power ground connection (away from the switching currents).

3) Put the feedback resistors close to the V_{FB} pins. The trace connecting the top feedback resistor (R_B) to the output capacitor should be a Kelvin trace. The I_{TH} compensation components should also be very close to the LTC3776.

4) The current sense traces (SENSE+ and SW) should be Kelvin connections right at the P-channel MOSFET source and drain.

5) Keep the switch nodes (SW1, SW2) and the gate driver nodes (TG1, TG2, BG1, BG2) away from the small-signal components, especially the opposite channels feedback resistors, I_{TH} compensation components and the current sense pins (SENSE+ and SW).

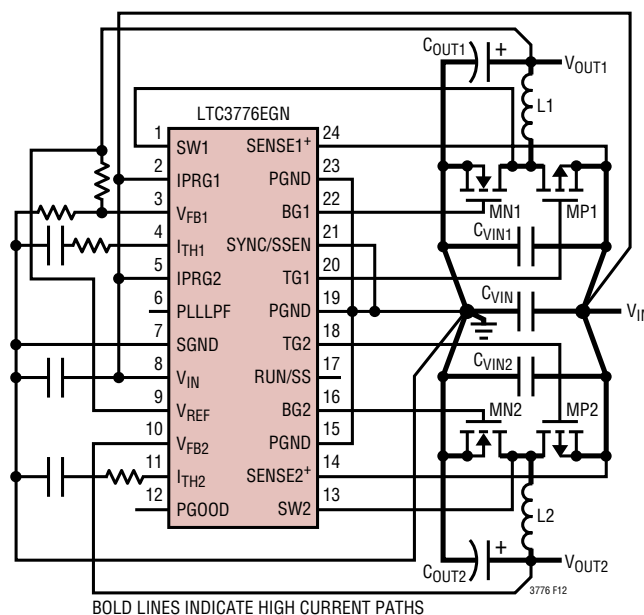

Figure 12. LTC3776 Layout Diagram

APPLICATIONS INFORMATION

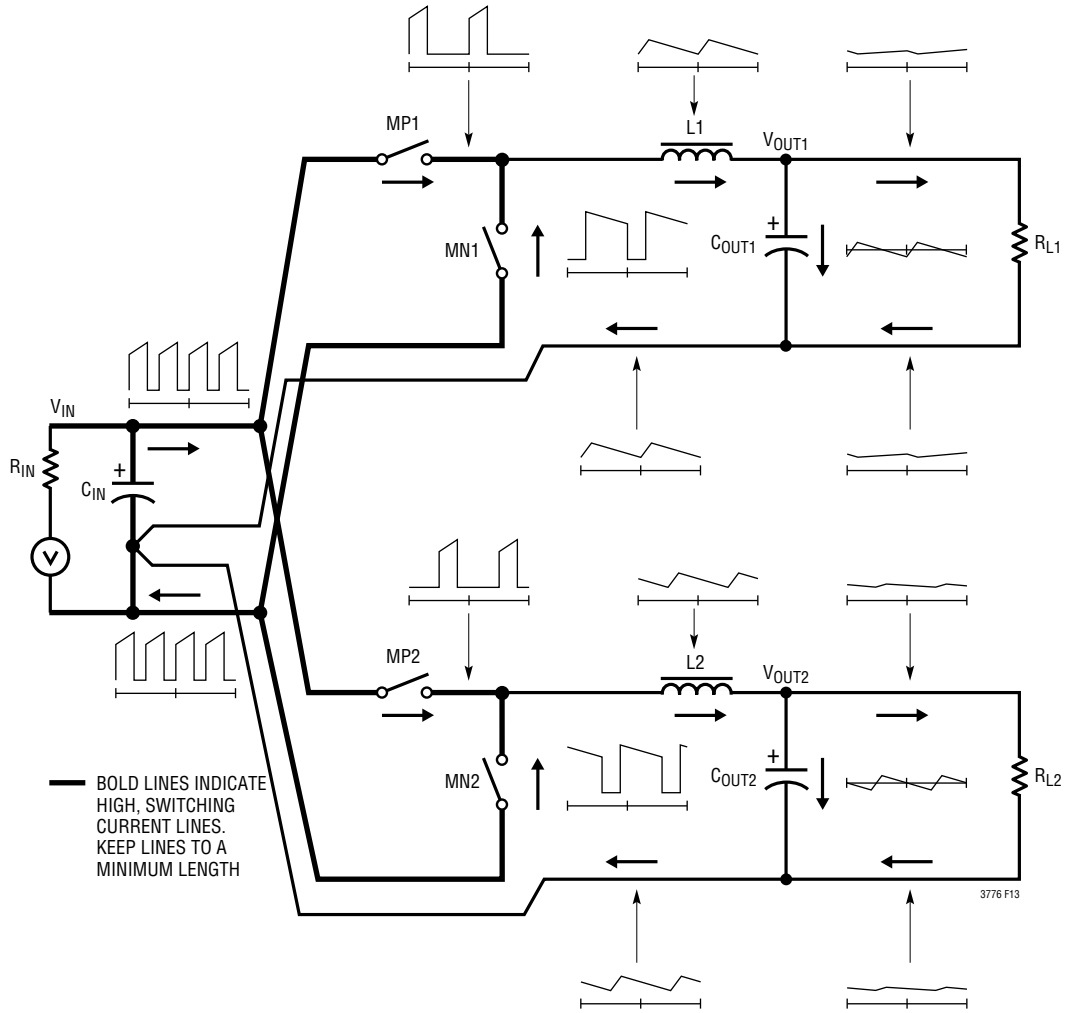

Figure 13. Branch Current Waveforms

TYPICAL APPLICATIONS

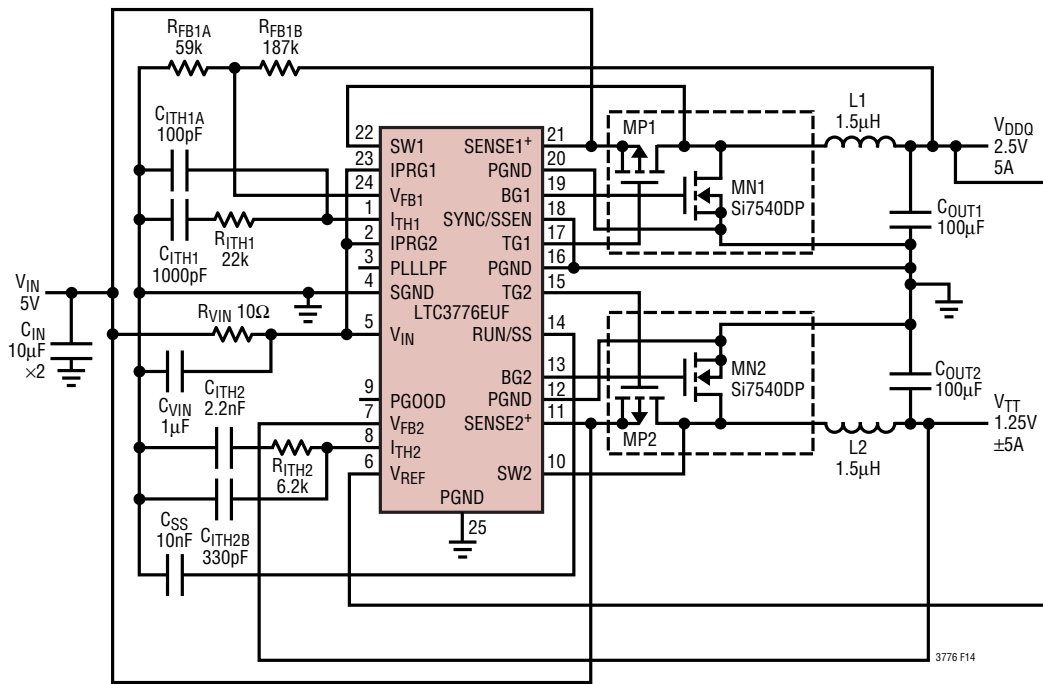

Figure 14. 2-Phase, 550kHz, DDR Memory Supplies

TYPICAL APPLICATIONS

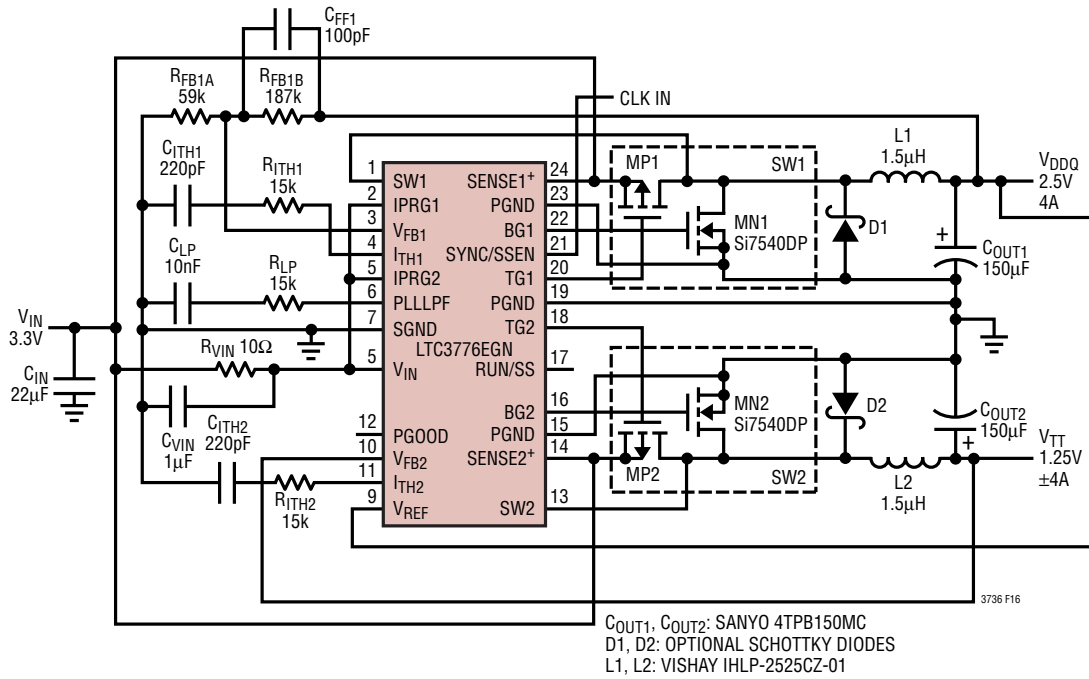
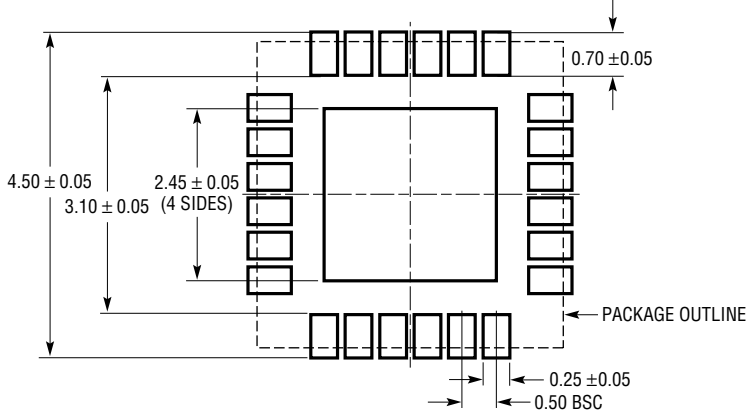

Figure 16. 2-Phase, Synchronizable, DDR Memory Supplies

PACKAGE DESCRIPTION

UF Package
24-Lead Plastic QFN (4mm × 4mm)
 (Reference LTC DWG # 05-08-1697)



RECOMMENDED SOLDER PAD PITCH AND DIMENSIONS

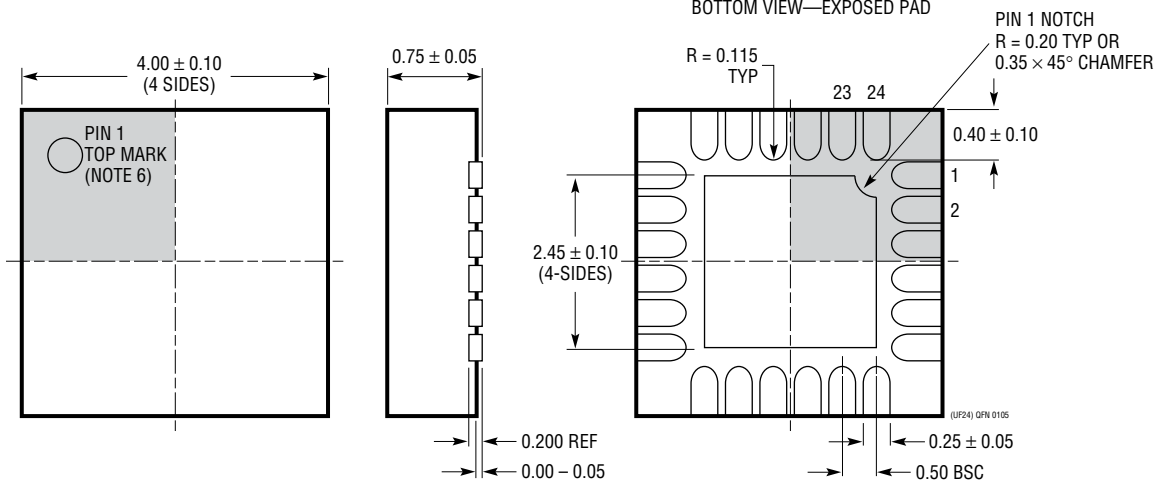

- NOTE:
1. DRAWING PROPOSED TO BE MADE A JEDEC PACKAGE OUTLINE MO-220 VARIATION (WGGD-X)—TO BE APPROVED
 2. DRAWING NOT TO SCALE
 3. ALL DIMENSIONS ARE IN MILLIMETERS
 4. DIMENSIONS OF EXPOSED PAD ON BOTTOM OF PACKAGE DO NOT INCLUDE MOLD FLASH. MOLD FLASH, IF PRESENT, SHALL NOT EXCEED 0.15mm ON ANY SIDE, IF PRESENT
 5. EXPOSED PAD SHALL BE SOLDER PLATED
 6. SHADED AREA IS ONLY A REFERENCE FOR PIN 1 LOCATION ON THE TOP AND BOTTOM OF PACKAGE

PACKAGE DESCRIPTION

GN Package 24-Lead Plastic SSOP (Narrow .150 Inch) (Reference LTC DWG # 05-08-1641)

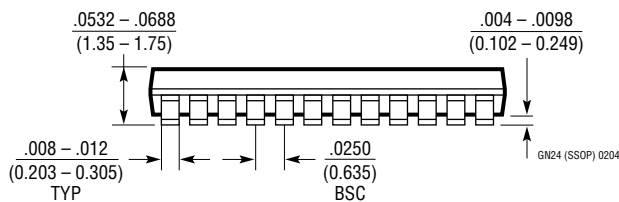
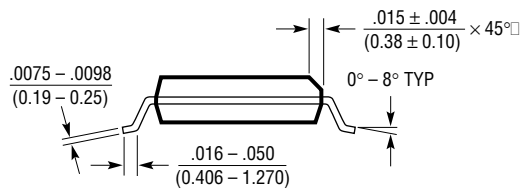
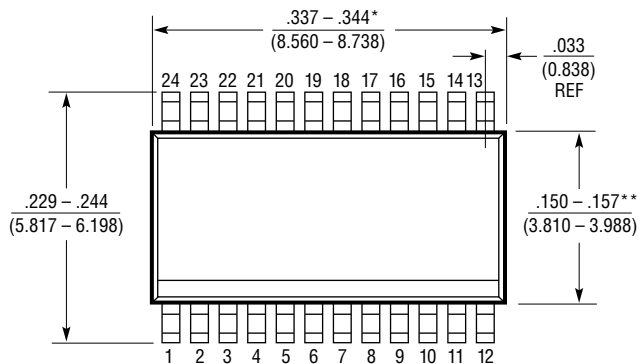
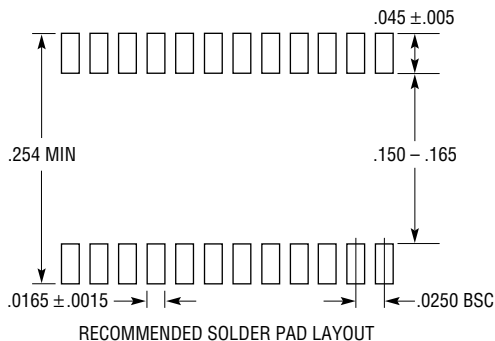

NOTE:

1. CONTROLLING DIMENSION: INCHES
 2. DIMENSIONS ARE IN $\frac{\text{INCHES}}{\text{MILLIMETERS}}$
 3. DRAWING NOT TO SCALE
- *DIMENSION DOES NOT INCLUDE MOLD FLASH. MOLD FLASH SHALL NOT EXCEED 0.006" (0.152mm) PER SIDE
- **DIMENSION DOES NOT INCLUDE INTERLEAD FLASH. INTERLEAD FLASH SHALL NOT EXCEED 0.010" (0.254mm) PER SIDE

TYPICAL APPLICATION

2-Phase, Spread Spectrum, DDR Memory Supplies with Ceramic Output Capacitors

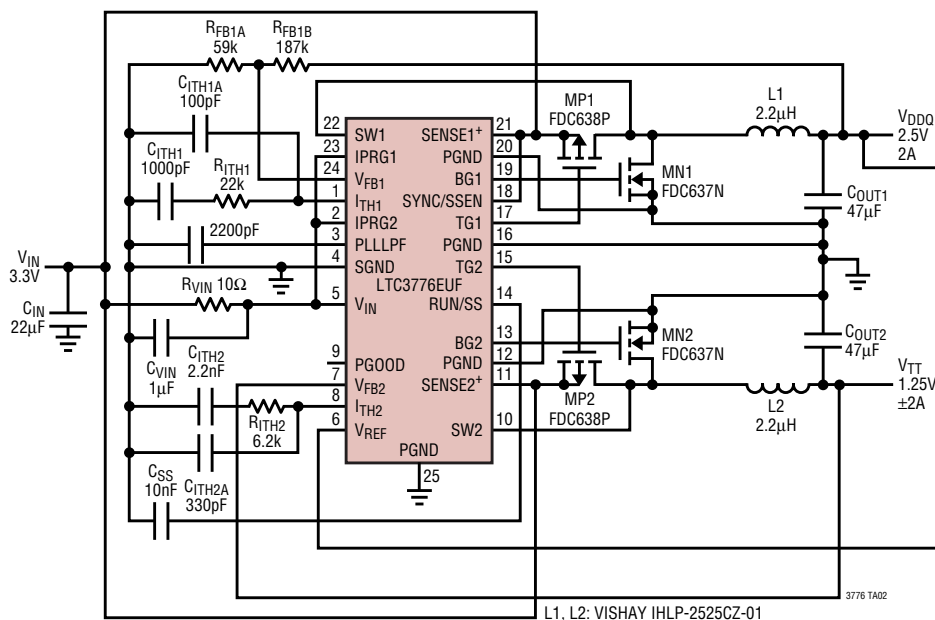

RELATED PARTS

PART NUMBER	DESCRIPTION	COMMENTS
LTC1735	High Efficiency Synchronous Step-Down Controller	Burst Mode Operation, 16-Pin Narrow SSOP, Fault Protection, $3.5V \leq V_{IN} \leq 36V$
LTC1772	Constant Frequency Current Mode Step-Down DC/DC Controller	$2.5V \leq V_{IN} \leq 9.8V$, I_{OUT} Up to 4A, SOT-23 Package, 550kHz
LTC1778	No R_{SENSE}^{TM} Synchronous Step-Down Controller	Current Mode Operation Without Sense Resistor, Fast Transient Response, $4V \leq V_{IN} \leq 36V$
LTC2923	Power Supply Tracking Controller	Controls Up to Three Supplies, 10-Lead MSOP
LTC3411	1.25A (I_{OUT}), 4MHz, Synchronous Step-Down DC/DC Converter	95% Efficiency, V_{IN} : 2.5V to 5.5V, $V_{OUT} = 0.8V$, $I_Q = 60\mu A$, $I_{SD} < 1\mu A$, MS Package
LTC3412	2.5A (I_{OUT}), 4MHz, Synchronous Step-Down DC/DC Converter	95% Efficiency, V_{IN} : 2.5V to 5.5V, $V_{OUT} = 0.8V$, $I_Q = 60\mu A$, $I_{SD} < 1\mu A$, TSSOP-16E Package
LTC3413	3A Monolithic DDR Memory Termination Regulator	$\pm 3A$ Output Current, $2.25V \leq V_{IN} \leq 5.5V$
LTC3701	2-Phase, Low Input Voltage Dual Step-Down DC/DC Controller	$2.5V \leq V_{IN} \leq 9.8V$, 550kHz, PGOOD, PLL, 16-Lead SSOP
LTC3708	Fast 2-Phase, No R_{SENSE} Buck Controller with Output Tracking	Constant On-Time Dual Controller, V_{IN} Up to 36V, Very Low Duty Cycle Operation, 5mm x 5mm QFN Package
LTC3717	High Power DDR Memory Termination Regulator	$4V \leq V_{IN} \leq 36V$, V_{OUT} Tracks V_{IN} or V_{REF} , I_{OUT} from 1A to 20A
LTC3728/LTC3728L	Dual, 550kHz, 2-Phase Synchronous Step-Down Switching Regulator	Constant Frequency, V_{IN} to 36V, 5V and 3.3V LDOs, 5mm x 5mm QFN or 28-Lead SSOP
LTC3736	Dual, 2-Phase, No R_{SENSE} , Synchronous Controller with Output Tracking	V_{IN} : 2.75 to 9.8V, I_{OUT} up to 5A, 4mm x 4mm QFN Package
LTC3736-1	Dual, 2-Phase, No R_{SENSE} , Synchronous Controller with Spread Spectrum	V_{IN} : 2.75 to 9.8V, Spread Spectrum Operation, Output Voltage Tracking, 4mm x 4mm QFN Package
LTC3737	Dual, 2-Phase, No R_{SENSE} , Controller with Output Tracking	V_{IN} : 2.75 to 9.8V, I_{OUT} up to 5A, 4mm x 4mm QFN Package
LTC3831	High Power DDR Memory Termination Regulator	V_{OUT} Tracks $1/2 V_{IN}$ or V_{REF} , $3V \leq V_{IN} \leq 8V$, I_{OUT} from 1A to 20A

No R_{SENSE} is a trademark of Linear Technology Corporation.

3776fa

Looking for pricing, stock, or lifecycle information?

Click below to explore more details on WIN SOURCE:

 [View DC829A](#) on WIN SOURCE

 [Linear Technology](#) Information

Optimize Your Supply Chain with WIN SOURCE Solutions

-  Global Sourcing Solution
-  Obsolete Management
-  Cost Control Management
-  Shortage Management
-  Alternative Solution
-  Excess Inventory Management