



**THE DATASHEET OF
LTC2995CUD#PBF**



Temperature Sensor and Dual Voltage Monitor with Alert Outputs

FEATURES

- Monitors Temperature and Two Voltages
- Voltage Output Proportional to Temperature
- Adjustable Thresholds for Temperature and Voltage
- $\pm 1^\circ\text{C}$ Remote Temperature Accuracy
- $\pm 2^\circ\text{C}$ Internal Temperature Accuracy
- $\pm 1.5\%$ Voltage Threshold Accuracy
- 3.5ms Update Time
- 2.25V to 5.5V Supply Voltage
- Input Glitch Rejection
- Adjustable Reset Timeout
- 220 μA Quiescent Current
- Open Drain Alert Outputs
- Available in 3mm \times 3mm QFN Package

APPLICATIONS

- Network Servers
- Core, I/O Voltage Monitors
- Desktop and Notebook Computers
- Environmental Monitoring

DESCRIPTION

The LTC[®]2995 is a high accuracy temperature sensor and dual supply monitor. It converts the temperature of an external diode sensor and/or its own die temperature to an analog output voltage while rejecting errors due to noise and series resistance. Two supply voltages and the measured temperature are compared against upper and lower limits set with resistive dividers. If a threshold is exceeded, the device communicates an alert by pulling low the correspondent open drain logic output.

The LTC2995 gives $\pm 1^\circ\text{C}$ accurate temperature results using commonly available NPN or PNP transistors or temperature diodes built into modern digital devices. Voltages are monitored with 1.5% accuracy. A 1.8V reference output simplifies threshold programming and can be used as an ADC reference input.

The LTC2995 provides an accurate, low power solution for temperature and voltage monitoring in a compact 3mm \times 3mm QFN package.

LT, LT, LTC, LTM, Linear Technology and the Linear logo are registered trademarks of Linear Technology Corporation. All other trademarks are the property of their respective owners.

TYPICAL APPLICATION

Dual OV/UV Supply and Single OT/UT Remote Temperature Monitor

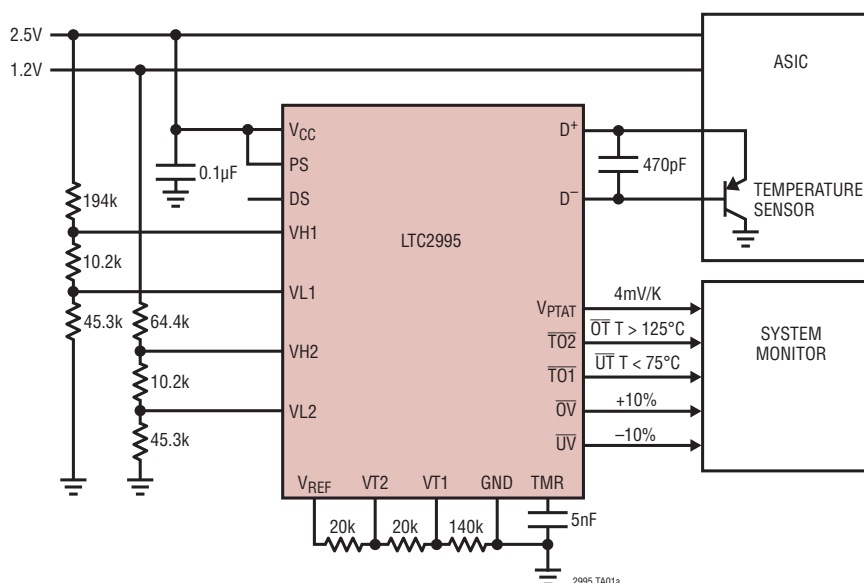

V_{PTAT} vs Remote Diode Temperature

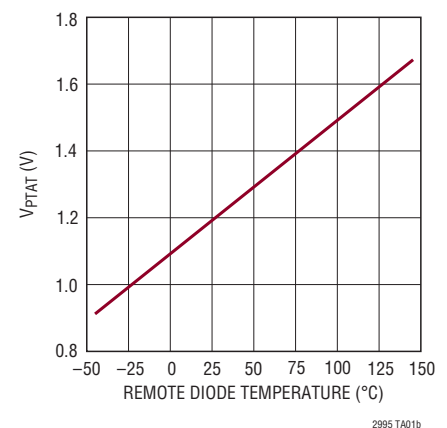

2995 TA01b

ABSOLUTE MAXIMUM RATINGS

(Notes 1, 2)

V_{CC}	-0.3V to 6V
TMR, D^+ , D^- , DS, PS, V_{PTAT} , V_{REF}	-0.3V to $V_{CC} + 0.3V$
\overline{UV} , \overline{OV} , $\overline{TO1}$, $\overline{TO2}$	-0.3V to 6V
VH1, VL1, VH2, VL2, VT1, VT2.....	-0.3V to 6V
Operating Ambient Temperature Range	
LTC2995C	0°C to 70°C
LTC2995I	-40°C to 85°C
LTC 2995H.....	-40°C to 125°C
Storage Temperature Range	-65°C to 150°C

PIN CONFIGURATION

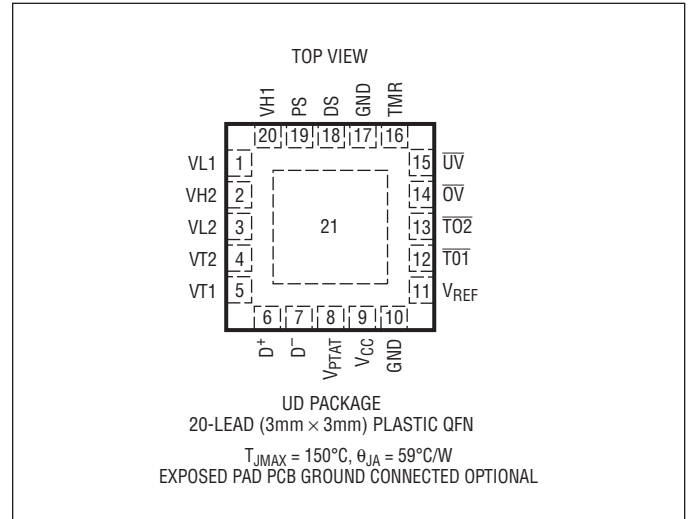

ORDER INFORMATION

LEAD FREE FINISH	TAPE AND REEL	PART MARKING*	PACKAGE DESCRIPTION	TEMPERATURE RANGE
LTC2995CUD#PBF	LTC2995CUD#TRPBF	LFQV	20-Lead (3mm × 3mm) Plastic QFN	0°C to 70°C
LTC2995IUD#PBF	LTC2995IUD#TRPBF	LFQV	20-Lead (3mm × 3mm) Plastic QFN	-40°C to 85°C
LTC2995HUD#PBF	LTC2995HUD#TRPBF	LFQV	20-Lead (3mm × 3mm) Plastic QFN	-40°C to 125°C

Consult LTC Marketing for parts specified with wider operating temperature ranges. *The temperature grade is identified by a label on the shipping container.

For more information on lead free part marking, go to: <http://www.linear.com/leadfree/>

For more information on tape and reel specifications, go to: <http://www.linear.com/tapeandreel/>

ELECTRICAL CHARACTERISTICS

The ● denotes the specifications which apply over the full operating temperature range, otherwise specifications are at $T_A = 25^{\circ}C$, $V_{CC} = 3.3V$, unless otherwise noted.

SYMBOL	PARAMETER	CONDITIONS	MIN	TYP	MAX	UNITS	
V_{CC}	Supply Voltage		● 2.25		5.5	V	
UVLO	Supply Undervoltage Lockout Threshold	V_{CC} Falling	● 1.7	1.9	2.1	V	
I_{CC}	Average Supply Current		●	220	300	μA	
Temperature Measurement							
V_{REF}	Reference Voltage	LTC2995	●	1.797	1.8	1.803	V
		LTC2995C	●	1.793	1.8	1.804	V
		LTC2995I	●	1.790	1.8	1.807	V
		LTC2995H	●	1.787	1.8	1.808	V
	V_{REF} Load Regulation	$I_{LOAD} = \pm 200\mu A$	●		± 1.5	mV	
	Remote Diode Sense Current			-8	-192	μA	

ELECTRICAL CHARACTERISTICS

The ● denotes the specifications which apply over the full operating temperature range, otherwise specifications are at $T_A = 25^\circ\text{C}$, $V_{CC} = 3.3\text{V}$, unless otherwise noted.

SYMBOL	PARAMETER	CONDITIONS	MIN	TYP	MAX	UNITS
T_{conv}	Temperature Update Interval	●		3.5	5	ms
K_T	V_{PTAT} Slope	Ideality Factor $\eta = 1.004$		4		mV/K
	V_{PTAT} Load Regulation	$I_{\text{LOAD}} = \pm 200\mu\text{A}$			± 1.5	mV
T_{int}	Internal Temperature Accuracy	$T_{\text{AMB}} = -40^\circ\text{C}$ to 125°C		± 0.5 ± 2	± 1	$^\circ\text{C}$ $^\circ\text{C}$
T_{RMT}	Remote Temperature Error, $\eta = 1.004$	0°C to 85°C (Notes 3, 4) -40°C to 0°C (Notes 3, 4) 85°C to 125°C (Notes 3, 4)		± 0.25 ± 0.25 ± 0.25	± 1 ± 1.5 ± 1.5	$^\circ\text{C}$ $^\circ\text{C}$ $^\circ\text{C}$
	Temperature Noise			0.15 0.01		$^\circ\text{C}_{\text{RMS}}$ $^\circ\text{C}_{\text{RMS}}/\sqrt{\text{Hz}}$
T_{VCC}	Temperature Error vs Supply	●			± 0.5	$^\circ\text{C}/\text{V}$
T_{RS}	Series Resistance Cancellation Error	$R_{\text{SERIES}} = 100\Omega$	●	± 0.25	± 1	$^\circ\text{C}$

Temperature and Voltage Monitoring

V_{UOT}	Undervoltage/Overvoltage Threshold	●	492	500	508	mV
T_{OFF}	VT1, VT2 Offset	●	-3	-1	1	$^\circ\text{C}$
ΔT_{HYST}	VT1, VT2 Temperature Hysteresis	●	2	5	10	$^\circ\text{C}$
t_{UOD}	UV, OV	Input 5mV Above/Below Threshold	●	0.5	2	ms
I_{IN}	VH1, VL1, VH2, VL2, VT1, VT2, Input Current	●			± 20	nA
t_{UOTO}	$\overline{\text{UV}}/\overline{\text{OV}}$ Time-Out-Period	$C_{\text{TMR}} = \text{TMR Open}$ $C_{\text{TMR}} = 1\text{nF}$	●	5	0.5 10 20	ms ms
I_{TMR}	TMR Current	●			± 2.5	μA

Three State Pins DS, PS

$V_{\text{DS,PS(H,TH)}}$	PS, DS Input High Threshold	●	$V_{\text{CC}} - 0.4$		$V_{\text{CC}} - 0.1$	V
$V_{\text{DS,PS(H,TL)}}$	PS, DS Input Low Threshold	●	0.1		0.4	V
$I_{\text{DS,PS(IN,HL)}}$	PS, DS High, Low Input Current	●			± 4	μA
$I_{\text{DS,PS(IN,Z)}}$	Allowable Leakage Current	●			± 1	μA

Digital Outputs

V_{OH}	High Level Output Voltage, $\overline{\text{TO1}}, \overline{\text{TO2}}, \overline{\text{UV}}, \overline{\text{OV}}$	$I = -0.5\mu\text{A}$	●	$V_{\text{CC}} - 1.2$		V
V_{OL}	Low Level Output Voltage, $\overline{\text{TO1}}, \overline{\text{TO2}}, \overline{\text{UV}}, \overline{\text{OV}}$	$I = 3\text{mA}$	●		0.4	V

Note 1: Stresses beyond those listed under Absolute Maximum Ratings may cause permanent damage to the device. Exposure to any Absolute Maximum Rating condition for extended periods may affect device reliability and lifetime.

Note 2: All currents into pins are positive; all voltages are referenced to GND unless otherwise noted.

Note 3: Remote diode temperature, not LTC2995 temperature.

Note 4: Guaranteed by design and test correlation.

TIMING DIAGRAMS

VHn Monitor Timing

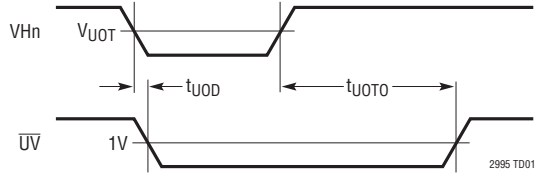

VLn Monitor Timing

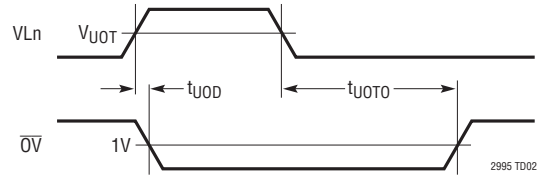

VHn Monitor Timing (TMR Pin Strapped to VCC)

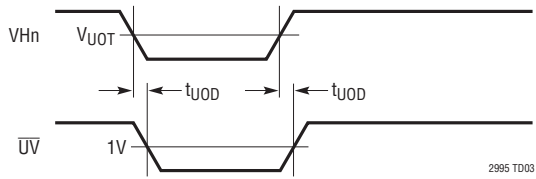

VLn Monitor Timing (TMR Pin Strapped to VCC)

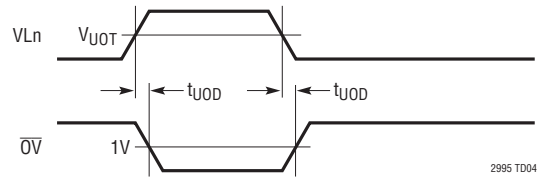

TYPICAL PERFORMANCE CHARACTERISTICS

$T_A = 25^\circ\text{C}$, $V_{CC} = 3.3\text{V}$ unless otherwise noted.

Temperature Error with LTC2995 at Same Temperature as Remote Diode

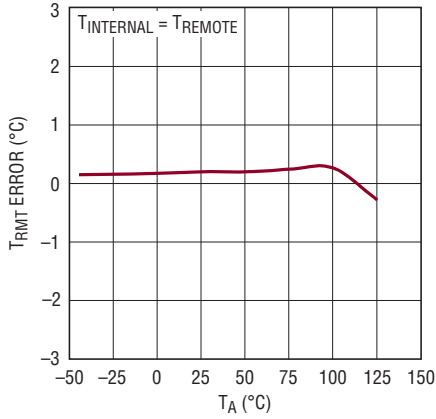

2995 G01

Remote Temperature Error vs Ambient Temperature

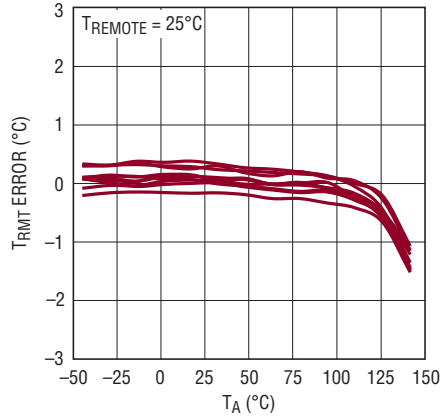

2995 G02

Internal Temperature Error vs Ambient Temperature

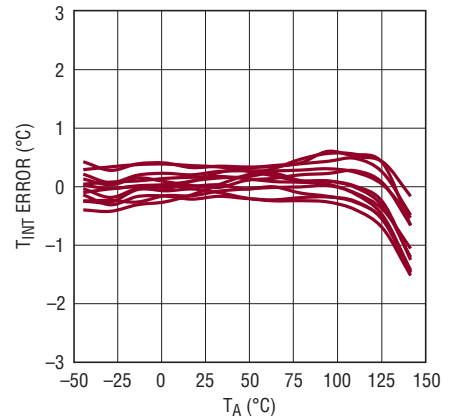

2995 G03

Temperature Error vs Supply Voltage

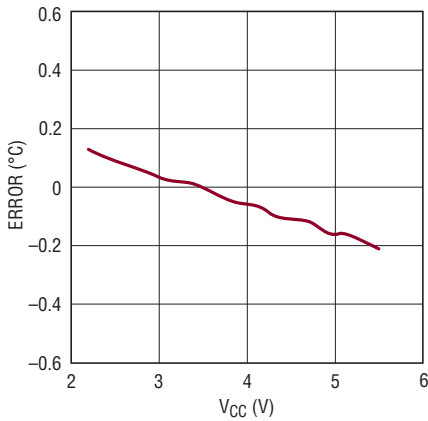

2995 G04

Remote Temperature Error vs Series Resistance

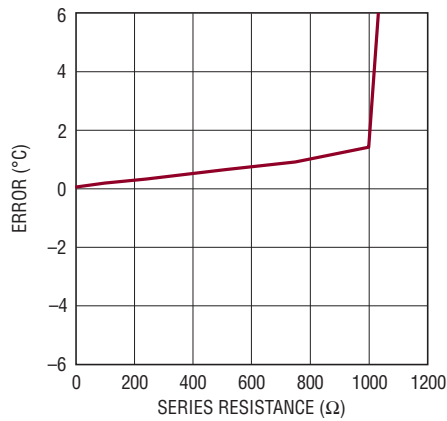

2995 G05

Remote Temperature Error vs C_DECOUPLE (Between D+ and D-)

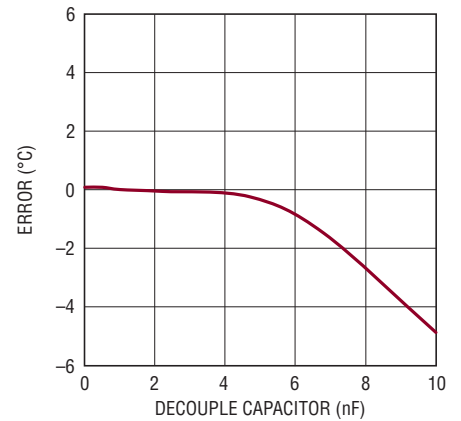

2995 G06

V_{PTAT} Noise vs Averaging Time

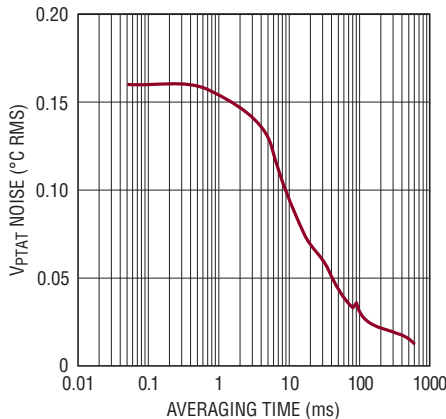

2995 G07

UVLO vs Temperature V_{CC} Rising, Falling

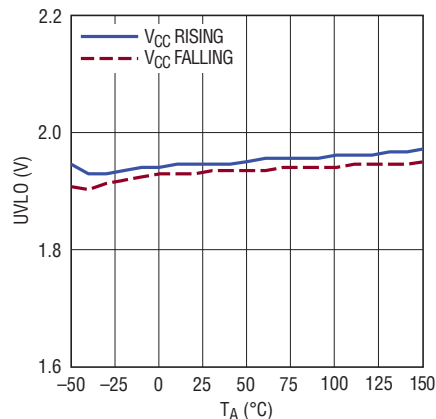

2995 G08

Buffered Reference Voltage vs Temperature

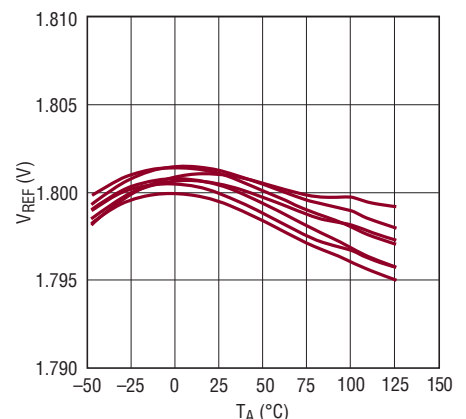

2995 G09

TYPICAL PERFORMANCE CHARACTERISTICS

$T_A = 25^\circ\text{C}$, $V_{CC} = 3.3\text{V}$ unless otherwise noted.

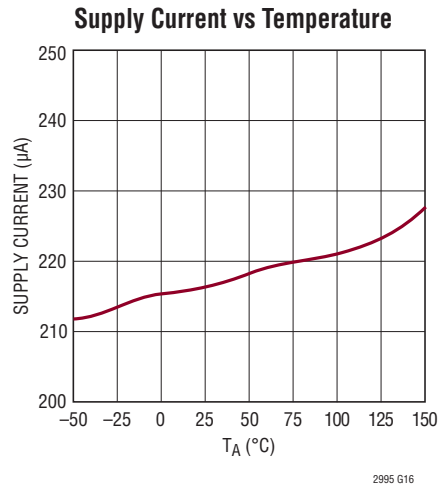
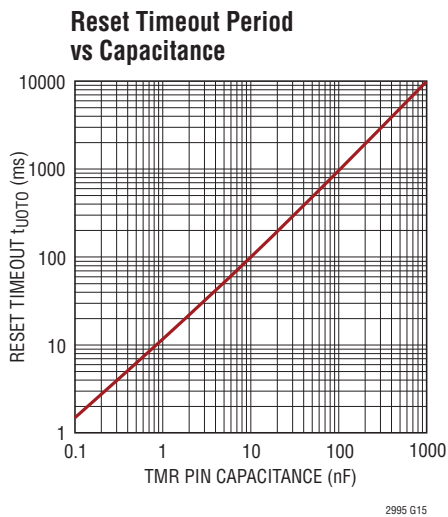
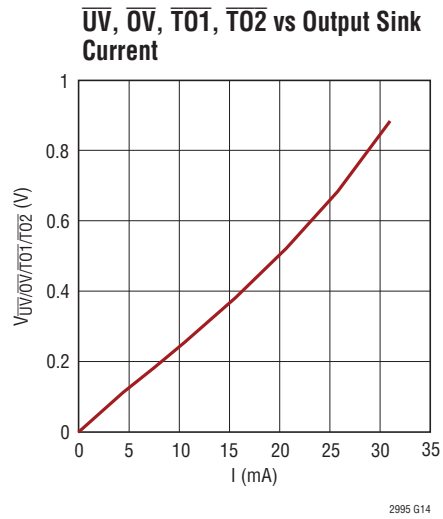
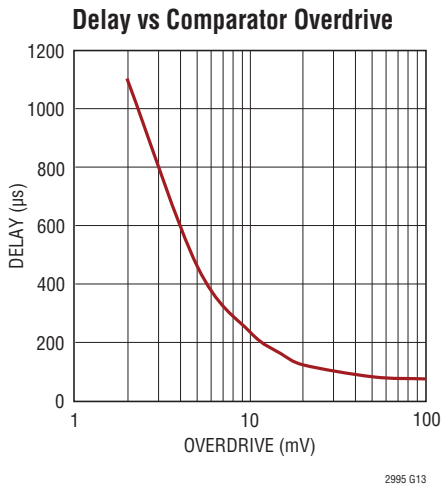
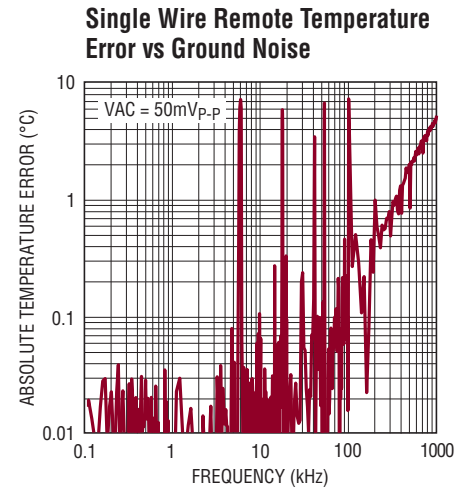
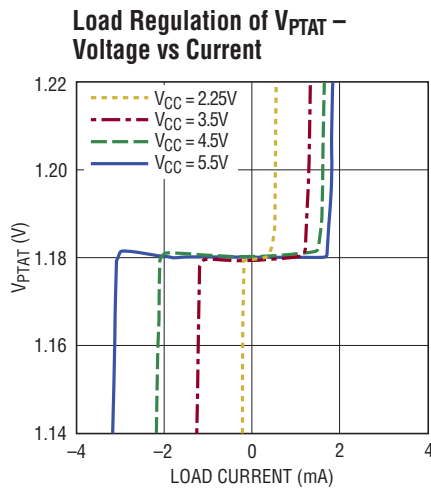
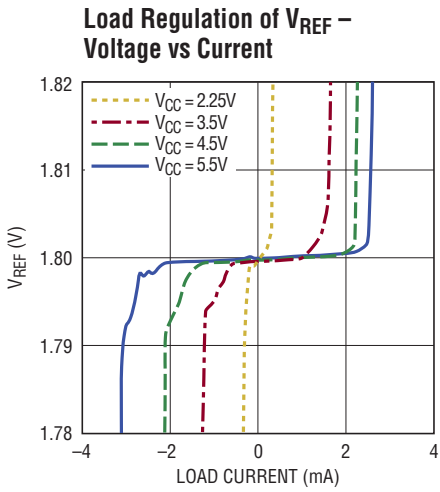

PIN FUNCTIONS

D⁺: Diode Sense Current Source. D⁺ sources the remote diode sensing current. Connect D⁺ to the anode of the remote sensor device. It is recommended to connect a 470pF bypass capacitor between D⁺ and D⁻. Larger capacitors may cause settling time errors (see Typical Performance Characteristics). If D⁺ is tied to V_{CC}, the LTC2995 measures the internal sensor temperature. Tie D⁺ to V_{CC} if unused.

D⁻: Diode Sense Current Sink. Connect D⁻ to the cathode of the remote sensor device. Tie D⁻ to GND for single wire remote temperature measurement (see Applications Information) or internal temperature sensing.

DS: Diode Select Input. Three state pin that selects temperature sensor location. Tie DS to V_{CC} to monitor the temperature of the internal diode or to GND to monitor the temperature of the external diode. When DS is left unconnected, the LTC2995 monitors both sensors alternately. If D⁺ is tied to V_{CC}, the LTC2995 measures the internal sensor temperature regardless of the state of DS.

Exposed Pad: Exposed pad may be left open or soldered to GND for better thermal coupling.

GND: Device Ground

\overline{OV} : Overvoltage Logic Output. Open drain logic output that pulls to GND when either the voltage at VL1 or VL2 is above 0.5V. Held low for a programmable delay time set by the capacitor connected to pin TMR. \overline{OV} has a weak 400k Ω pull-up to V_{CC} and may be pulled above V_{CC} using an external pull-up. Leave \overline{OV} open if unused.

PS: Polarity Select Input. Selects the polarity of temperature thresholds VT1 and VT2. Connect PS to V_{CC} to configure VT1 as undertemperature and VT2 as overtemperature threshold. Leave PS unconnected to configure both VT1 and VT2 as overtemperature thresholds. Connect PS to GND to configure both VT1 and VT2 as undertemperature thresholds. Tie to V_{CC} if temperature thresholds are unused.

TMR: Reset Delay Timer. Attach an external capacitor (CTMR) to GND to set the delay time until alerts on $\overline{TO1}$, $\overline{TO2}$, \overline{UV} and \overline{OV} are reset. Leaving the pin open generates a minimum delay of 500 μ s. Capacitance on this pin adds an additional 8ms/nF reset delay time. Tie TMR to V_{CC} to bypass the timer.

$\overline{TO1}$: Temperature Logic Output 1. Open drain logic output that pulls to GND when V_{PTAT} crosses the threshold voltage on pin VT1 with a polarity set by the PS pin (see Table 3 in Applications Information). When V_{PTAT} crosses the threshold voltage on pin VT1 with opposite polarity, an additional hysteresis of 20mV is required to release $\overline{TO1}$ high after a delay adjustable by the capacitor on TMR. $\overline{TO1}$ has a weak 400k Ω pull-up to V_{CC} and may be pulled above V_{CC} using an external pull-up. Leave $\overline{TO1}$ open if unused.

$\overline{TO2}$: Temperature Logic Output 2. Open drain logic output that pulls to GND when V_{PTAT} crosses the threshold voltage on pin VT2 with a polarity set by the PS pin (see Table 3 in Applications Information). When V_{PTAT} crosses the threshold voltage on pin VT2 with opposite polarity, an additional hysteresis of 20mV is required to release $\overline{TO2}$ high after a delay adjustable by the capacitor on TMR. $\overline{TO2}$ has a weak 400k Ω pull-up to V_{CC} and may be pulled above V_{CC} using an external pull-up. Leave $\overline{TO2}$ open if unused.

\overline{UV} : Undervoltage Logic Output. Open drain logic output that pulls to GND when either the voltage at VH1 or VH2 is below 0.5V. Held low for an adjustable delay time set by the capacitor connected to pin TMR. \overline{UV} has a weak 400k Ω pull-up to V_{CC} and may be pulled above V_{CC} using an external pull-up. Leave pin open if unused.

V_{CC}: Supply Voltage. Bypass this pin to GND with a 0.1 μ F (or greater) capacitor. V_{CC} operating range is 2.25V to 5.5V.

VH1, VH2: Voltage High Inputs 1 and 2. When the voltage on either pin is below 0.5V, an undervoltage condition is triggered. Tie pin to V_{CC} if unused.

VL1, VL2: Voltage Low Inputs 1 and 2. When the voltage on either pin is above 0.5V, an overvoltage condition is triggered. Tie pin to GND if unused.

V_{PTAT}: Proportional to Absolute Temperature Voltage Output. The voltage on this pin is proportional to the selected sensor's absolute temperature. An internal or external sensor is chosen with the DS pin. V_{PTAT} can drive up to $\pm 200\mu$ A of load current and up to 1000pF of capacitive load. For larger load capacitances insert a 1k

OPERATION

Overview

The LTC2995 combines the functionality of a temperature measurement and monitor device with a dual voltage supervisor. It provides a buffered voltage proportional to the absolute temperature of either an internal or a remote diode (V_{PTAT}) and compares this voltage to thresholds that can be set by external resistor dividers from the on-board reference (V_{REF}).

The LTC2995 also provides four voltage threshold inputs that are continuously compared to an internal 0.5V reference allowing two systems voltages to be monitored for undervoltage and overvoltage conditions.

Diode Temperature Sensor

Temperature measurements are conducted by measuring the voltage of either an internal or an external diode with multiple test currents. The relationship between diode voltage V_D and diode current I_D can be solved for absolute Temperature in degrees Kelvin T:

$$T = \frac{q}{\eta \cdot k} \cdot \frac{V_D}{\ln\left(\frac{I_D}{I_S}\right)}$$

where I_S is a process dependent factor on the order of $10^{-13}A$, η is the diode ideality factor, k is the Boltzmann constant and q is the electron charge. This equation shows a relationship between temperature and voltage dependent

on the process dependent variable I_S . Measuring the same diode (with the same value I_S) at two different currents (I_{D1} and I_{D2}) yields an expression independent of I_S :

$$T = \frac{q}{\eta \cdot k} \cdot \frac{V_{D2} - V_{D1}}{\ln\left(\frac{I_{D2}}{I_{D1}}\right)}$$

Series Resistance Cancellation

Resistance in series with the remote diode causes a positive temperature error by increasing the measured voltage at each test current. The composite voltage equals:

$$V_D + V_{ERROR} = \eta \frac{kT}{q} \cdot \ln\left(\frac{I_D}{I_S}\right) + R_S \cdot I_D$$

The LTC2995 removes this error term from the sensor signal by subtracting a cancellation voltage V_{CANCEL} . A resistance extraction circuit uses one additional current measurement to determine the series resistance in the measurement path. Once the correct value of the resistor is determined, V_{CANCEL} equals V_{ERROR} . Now the temperature to voltage converter input signal is free from errors due to series resistance.

LTC2995 can cancel series resistances up several hundred ohms (see Typical Performance Characteristics curves). Higher series resistances cause the cancellation voltage to saturate.

APPLICATIONS INFORMATION

Temperature Measurements

The LTC2995 continuously measures the sensor diode at different test currents and generates a voltage proportional to the absolute temperature of the sensor at the V_{PTAT} pin. The voltage at V_{PTAT} is updated every 3.5ms.

The gain of V_{PTAT} is calibrated to 4mV/K for the measurement of the internal diode as well as for remote diodes with an ideality factor of 1.004.

$$T_{KELVIN} = \frac{V_{PTAT}}{4mV/K} \quad (\eta = 1.004)$$

If an external sensor with an ideality factor different from 1.004 is used, the gain of V_{PTAT} will be scaled by the ratio of the actual ideality factor (η_{ACT}) to 1.004. In these cases, the temperature of the external sensor can be calculated from V_{PAT} by:

$$T_{KELVIN} = \frac{V_{PTAT}}{4mV/K} \cdot \frac{1.004}{\eta_{ACT}}$$

Temperature in degrees Celsius can be deduced from degrees Kelvin by:

$$T_{CELSIUS} = T_{KELVIN} - 273.15$$

The three-state diode select pin (DS) determines whether the temperature of the external or the internal diode is measured and displayed at V_{PTAT} as described in Table 1.

Table 1. Diode Selection

DIODE LOCATION	DS PIN
Internal	V_{CC}
External	GND
Both	Open

If the DS pin is left open, the LTC2995 measures both diodes alternately and V_{PTAT} changes every 30ms from the voltage corresponding to the temperature of the internal sensor to the voltage corresponding to the temperature of the external sensor. If D^+ is tied to V_{CC} , the LTC2995 measures the internal diode regardless of the state of the DS pin.

Choosing an External Sensor

The LTC2995 is factory calibrated for an ideality factor of 1.004, which is typical of the popular MMBT3904 NPN transistor. Semiconductor purity and wafer level processing intrinsically limit device-to-device variation, making these devices interchangeable between manufacturers with a temperature error of typically less than 0.5°C. Some recommended sources are listed in Table 2:

Table 2 Recommended Transistors for Use As Temperature Sensors

MANUFACTURER	PART NUMBER	PACKAGE
Fairchild Semiconductor	MMBT3904	SOT-23
Central Semiconductor	CMBT3904	SOT-23
Diodes Inc.	MMBT3904	SOT-23
On Semiconductor	MMBT3904LT1	SOT-23
NXP	MMBT3904	SOT-23
Infineon	MMBT3904	SOT-23
Rohm	UMT3904	SC-70

Discrete two terminal diodes are not recommended as remote sensing devices as their ideality factor is typically much higher than 1.004. Also MOS transistors are not suitable as they don't exhibit the required current to temperature relationship. Furthermore gold doped transistors (low beta), high frequency and high voltage transistors should be avoided as remote sensing devices.

Connecting an External Sensor

The change in sensor voltage per °C is hundreds of microvolts, so electrical noise must be kept to a minimum. Bypass D^+ and D^- with a 470pF capacitor close to the LTC2995 to suppress external noise. Recommended shielding and PCB trace considerations for best noise immunity are illustrated in Figure 1.

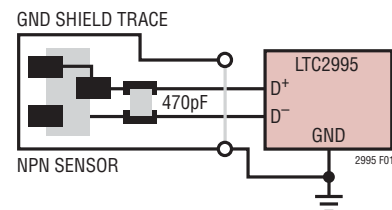

Figure 1. Recommended PCB Layout

APPLICATIONS INFORMATION

Leakage currents at D⁺ affect the precision of the remote temperature measurements. 100nA leakage current leads to an additional error of 2°C (see Typical Performance Characteristics).

Note that bypass capacitors greater than 1nF will cause settling time errors in the different measurement currents and therefore introduce an error in the temperature measurement (see Typical Performance Characteristics).

The LTC2995 compensates series resistance in the measurement path and thereby allows accurate remote temperature measurements even with several meters of distance between the sensor and the device. The cable length between the sensor and the LTC2995 is only limited by the mutual capacitance introduced between D⁺ and D⁻ which degrades measurement accuracy (see Typical Performance Characteristics).

For example an AT6 cable with 50pF/m should be kept shorter than ~20m to keep the capacitance less than 1nF.

To save wiring, the cathode of the remote sensor can also be connected to remote GND and D⁻ to local GND as shown below.

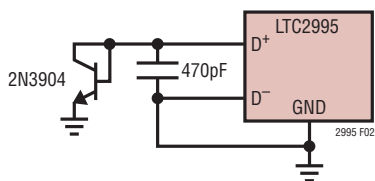

Figure 2. Single Wire Remote Temperature Sensing

The temperature measurement of the LTC2995 relies only on differences between the diode voltage at multiple test circuits. Therefore DC offsets smaller than 300mV between remote and local GND do not impact the precision of the temperature measurement. The cathode of the sensor can accommodate modest ground shifts across a system which is beneficial in applications where a good thermal connectivity of the sensor to a device whose temperature is to be monitored (shunt resistor, coil, etc.) is required. Care must be taken if the potential difference between the cathode and D⁻ does not only content DC but also AC

components. Noise around odd multiples of 6kHz ($\pm 20\%$) is amplified by the measurement algorithm and converted at a DC offset in the temperature measurement (see Typical Performance Characteristics).

The LTC2995 can withstand up to ± 4 kV of electrostatic discharge (ESD, human body). ESD beyond this voltage can damage or degrade the device including lowering the remote sensor measurement accuracy due to increased leakage currents on D⁺ or D⁻.

To protect the sensing inputs against larger ESD strikes, external protection can be added using TVS diodes to ground (Figure 3). Care must be taken to choose diodes with low capacitance and low leakage currents in order not to degrade the external sensor measurement accuracy (see Typical Performance Characteristics curves).

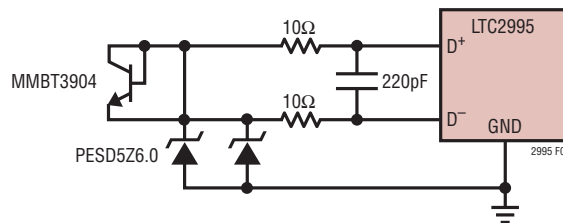

Figure 3. Increasing ESD Robustness with TVS Diodes

To make the connection of the cable to the IC polarity insensitive during installation, two sensor transistors with opposite polarity at the end of a two wire cable can be used as shown on Figure 4.

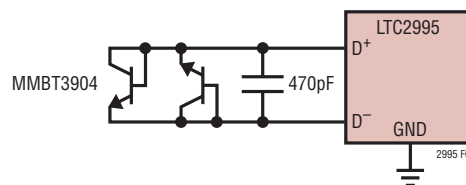

Figure 4. Polarity Insensitive Remote Diode Sensor

Again, care must be taken that the leakage current of the second transistor does not degrade the measurement accuracy.

APPLICATIONS INFORMATION

Output Noise Filtering

The V_{PTAT} output typically exhibits 0.6mV RMS (0.25°C RMS) noise. For applications which require lower noise digital or analog averaging can be applied to the output. Choose the averaging time according to:

$$t_{AVG} = \left(\frac{0.01 [^{\circ}\text{C}\sqrt{\text{Hz}}]}{T_{NOISE}} \right)^2$$

where t_{AVG} is the averaging time and T_{NOISE} the desired temperature noise in °C RMS. For example, if the desired noise performance is 0.015°C RMS, set the averaging time to one second. See Typical Performance Characteristics.

Temperature Monitoring

The LTC2995 continuously compares the voltage at V_{PTAT} to the voltages at the pins VT1 and VT2 to detect either an overtemperature (OT) or undertemperature (UT) condition. The VT1 comparator output drives the open-drain logic output pin $\overline{\text{TO1}}$ and the VT2 comparator output drives the open-drain logic output pin $\overline{\text{TO2}}$. The polarity of these comparisons is configured via the three-state polarity select pin (PS) (Table 3).

Table 3. Temperature Polarity Selection

PS PIN	FUNCTION	CONDITION	OUTPUT
V_{CC}	VT1 Undertemperature Threshold	$V_{PTAT} < VT1$	$\overline{\text{TO1}}$ Pulled Low
	VT2 Overtemperature Threshold	$V_{PTAT} > VT2$	$\overline{\text{TO2}}$ Pulled Low
Open	VT1 Overtemperature Threshold	$V_{PTAT} > VT1$	$\overline{\text{TO1}}$ Pulled Low
	VT2 Overtemperature Threshold	$V_{PTAT} > VT2$	$\overline{\text{TO2}}$ Pulled Low
GND	VT1 Undertemperature Threshold	$V_{PTAT} < VT1$	$\overline{\text{TO1}}$ Pulled Low
	VT2 Undertemperature Threshold	$V_{PTAT} < VT2$	$\overline{\text{TO2}}$ Pulled Low

If pin PS is connected to V_{CC} , the voltage on VT1 becomes an undertemperature threshold and the voltage on VT2 an overtemperature threshold. In this configuration $\overline{\text{TO1}}$ is

pulled low if the voltage V_{PTAT} falls during five consecutive conversions below the undertemperature threshold VT1. Once pulled low, $\overline{\text{TO1}}$ is released high again if V_{PTAT} rises above VT1 *plus* an additional hysteresis of about 20mV. Accordingly, $\overline{\text{TO2}}$ is pulled low if the voltage V_{PTAT} rises above the overtemperature threshold VT2 and—once pulled low— $\overline{\text{TO2}}$ is released high if V_{PTAT} falls below VT2 *minus* an additional hysteresis of about 20mV. Leaving PS unconnected configures both VT1 and VT2 as overtemperature thresholds and connecting PS to GND configures them both as undertemperature thresholds. If the internal and external sensors are monitored alternately by leaving DS unconnected, VT1 becomes a dedicated threshold for the internal sensor and VT2 becomes a dedicated threshold for the external sensor.

Temperature Monitor Design Example

The LTC2995 can be configured to give an early warning if the temperature of the internal sensor rises above 60°C and an alarm if the temperature passes 90°C. Tie the DS pin to V_{CC} to select the internal sensor and leave the pin PS unconnected to configure both input voltages VT1 and VT2 as overtemperature thresholds. The voltages at VT1 and VT2 are set to:

$$VT1 = (60\text{K} + 273.15\text{K}) \cdot 4 \frac{\text{mV}}{\text{K}} = 1.332\text{V}$$

$$VT2 = (90\text{K} + 273.15\text{K}) \cdot 4 \frac{\text{mV}}{\text{K}} = 1.452\text{V}$$

When V_{PTAT} reaches the threshold voltage on pin VT1, $\overline{\text{TO1}}$ is pulled low indicating an overtemperature early warning. If the temperature reaches 90°C $\overline{\text{TO2}}$ is also pulled low, indicating an overtemperature alarm.

Once the temperature drops below each threshold, the corresponding $\overline{\text{TO}}$ pins will return high after a time-out-period (t_{UOTO}) set by the capacitor connected to TMR.

APPLICATIONS INFORMATION

Temperature Thresholds

The threshold voltages at VT1 and VT2 can be set with the 1.8V reference voltage (V_{REF}) and a resistive divider as shown in Figure 5.

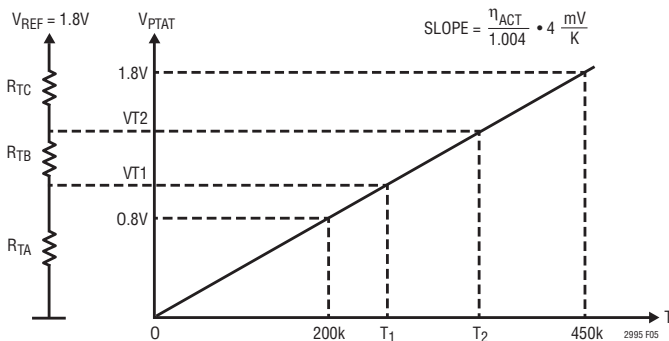

Figure 5. Temperature Thresholds

The following design procedure can be used to size the resistive divider.

1. Calculate Threshold Voltages:

$$VT1 = T1 \cdot 4 \frac{mV}{K} \cdot \frac{\eta_{ACT}}{1.004}$$

$$VT2 = T2 \cdot 4 \frac{mV}{K} \cdot \frac{\eta_{ACT}}{1.004}$$

where η_{ACT} denotes the actual ideality factor if an external sensor is used and T1 and T2 are the desired threshold temperatures in degrees Kelvin.

2. Choose R_{TA} to obtain the desired VT1 threshold for a desired current through the resistive divider (I_{REF}):

$$R_{TA} = \frac{VT1}{I_{REF}}$$

3. Choose R_{TB} to obtain the desired VT2 threshold:

$$R_{TB} = \frac{VT2 - VT1}{I_{REF}}$$

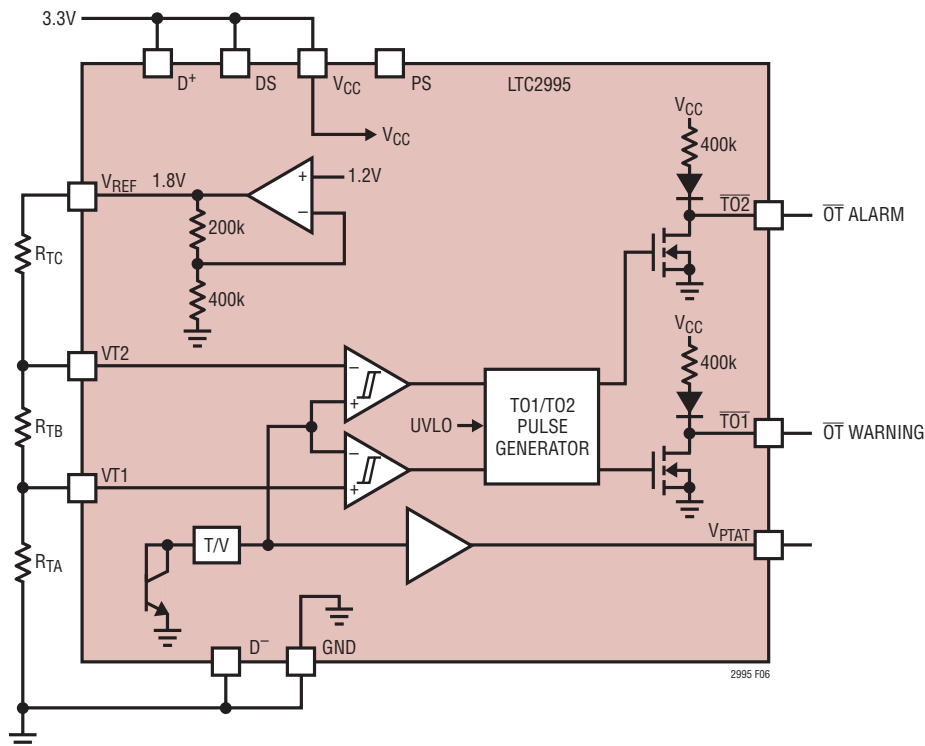

Figure 6. Monitoring Internal Temperature with Two Overtemperature Thresholds

APPLICATIONS INFORMATION

4. Finally R_{TC} is determined by:

$$R_{TC} = \frac{1.8V - VT2}{I_{REF}}$$

In the Temperature Monitor example discussed earlier with thresholds at $VT1 = 60^\circ\text{C}$ and $VT2 = 90^\circ\text{C}$ and a desired reference current of $10\mu\text{A}$, the required values for R_{TA} , R_{TB} and R_{TC} can be calculated as:

$$R_{TA} = \frac{1.332V}{10\mu\text{A}} = 133.2\text{k}$$

$$R_{TB} = \frac{1.452V - 1.332V}{10\mu\text{A}} = 12\text{k}$$

$$R_{TC} = \frac{1.8V - 1.452V}{10\mu\text{A}} = 34.8\text{k}$$

Voltage Monitoring

In addition to temperature measurement, the LTC2995 features a low power dual voltage monitoring circuit. Each voltage monitor has two inputs (V_{H1}/V_{L1} and V_{H2}/V_{L2}) for detecting undervoltage and overvoltage conditions. If either V_{H1} or V_{H2} falls below 0.5V (typical), the LTC2995 communicates an undervoltage condition by pulling \overline{UV} low. Similar, an overvoltage condition is flagged by pulling \overline{OV} low if either V_{L1} or V_{L2} rises above 0.5V .

When configured to monitor a positive voltage V_n using the 3-resistor circuit configuration shown in Figure 5, V_{Hn} will be connected to the high side tap of the resistive divider and V_{Ln} will be connected to the low side tap of the resistive divider.

Voltage Monitor Design Procedure

The following 3-step design procedure selects appropriate resistances to obtain the desired UV and OV trip points for the voltage monitor circuit in Figure 7.

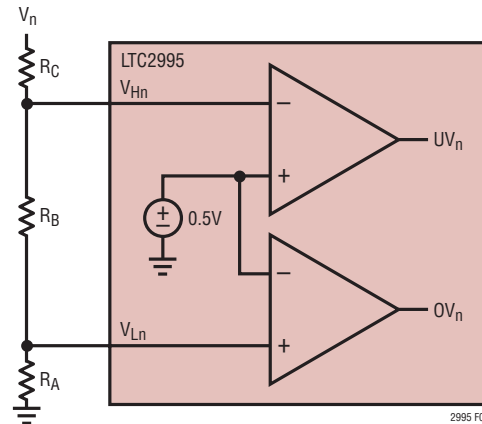

Figure 7. 3-Resistor Positive UV/OV Monitoring

For supply monitoring, V_n is the desired nominal operating voltage, I_n is the desired nominal current through the resistive divider, V_{OV} is the desired overvoltage trip point, and V_{UV} is the desired undervoltage trip point.

1. R_A is chosen to set the desired trip point for the overvoltage monitor:

$$R_A = \left| \frac{0.5V}{I_N} \cdot \frac{V_N}{V_{OV}} \right| \quad (1)$$

2. Once R_A is known, R_B is chosen to set the desired trip point for the undervoltage monitor:

$$R_B = \left| \frac{0.5V}{I_N} \cdot \frac{V_N}{V_{UV}} \right| - R_A \quad (2)$$

3. Once, R_A and R_B are known, R_C is determined by:

$$R_C = \left| \frac{V_N}{I_N} \right| - R_A - R_B \quad (3)$$

Voltage Monitor Example

A typical voltage monitor application is shown in Figure 2. The monitored voltage is a $5V \pm 10\%$ supply. Nominal current in the resistive divider is $10\mu\text{A}$.

1. Find R_A to set the OV trip point of the monitor:

$$R_A = \left| \frac{0.5V}{10\mu\text{A}} \cdot \frac{5V}{5.5V} \right| \approx 45.3\text{k}$$

APPLICATIONS INFORMATION

2. Find R_B to set the UV trip point of the monitor:

$$R_B = \left| \frac{0.5V}{10\mu A} \cdot \frac{5V}{4.5V} \right| - 453 \cong 10k$$

3. Determine R_C to complete the design:

$$R_C = \left| \frac{5V}{10\mu A} \right| - 453\Omega - 100\Omega \approx 442k$$

Power-Up and Undervoltage Lockout

As soon as V_{CC} reaches approximately 1V during power-up, the \overline{OV} as well as $\overline{TO1}$ and $\overline{TO2}$ weakly pull to V_{CC} while the \overline{UV} output asserts low indicating an undervoltage lockout condition. Above $V_{CC} = 2V$ (typical), the VH and VL inputs take control. Once both VH inputs and V_{CC} are valid, an internal timer is started. After an adjustable delay time, \overline{UV} weakly pulls high.

When V_{CC} falls below 1.9V, the LTC2995 indicates again an undervoltage lockout (UVLO) condition by pulling low \overline{UV} while \overline{OV} is cleared.

Threshold Accuracy

Reset threshold accuracy is important in a supply sensitive system. Ideally, such a system would only reset if supply voltages fell outside the exact threshold for a specified margin. All LTC2995 VH_n/VL_n inputs have a relative threshold accuracy of $\pm 1.5\%$ over the full operating temperature range. For example, when the LTC2995 is configured to monitor a 5V input with a 10% tolerance, the desired UV trip point is 4.5V. Because of the $\pm 1.5\%$ relative accuracy of the LTC2995, the UV trip point can be anywhere between 4.433V and 4.567V which is $4.5V \pm 1.5\%$.

Likewise, the accuracy of the resistances chosen for R_A , R_B , and R_C can affect the UV and OV trip points as well. Using the previous example, if the resistances used to set the UV trip point have 1% accuracy, the UV trip range can grow to between 4.354V and 4.650V. This is illustrated in the following calculations.

The UV trip point is given as:

$$V_{UV} = 0.5V \cdot \left(1 + \frac{R_C}{R_A + R_B} \right)$$

The two extreme conditions, with a relative accuracy of 1.5% and resistance accuracy of 1%, result in:

$$V_{UV(MIN)} = 0.5V \cdot 0.985 \cdot \left(1 + \frac{R_C \cdot 0.99}{(R_A + R_B) \cdot 1.01} \right)$$

and

$$V_{UV(MAX)} = 0.5V \cdot 1.015 \cdot \left(1 + \frac{R_C \cdot 1.01}{(R_A + R_B) \cdot 0.99} \right)$$

For a desired trip point of 4.5V, $\frac{R_C}{R_A + R_B} = 8$

Therefore,

$$V_{UV(MIN)} = 0.5V \cdot 0.985 \cdot \left(1 + 8 \frac{0.99}{1.01} \right) = 4.3545V$$

and

$$V_{UV(MAX)} = 0.5V \cdot 1.015 \cdot \left(1 + 8 \frac{1.01}{0.99} \right) = 4.650V$$

Glitch Immunity

In any supervisory application, noise on the monitored DC voltage can cause spurious resets. To solve this problem without adding hysteresis to the VH/VL comparators, which would add error to the trip voltage, the LTC2995 lowpass filters the output of the comparator. This filter causes the output of the comparator to be integrated before asserting the UV or OV logic. Any transient at the input of the comparator must be of sufficient magnitude and duration before the comparator will trigger the output logic. The Typical Performance Characteristics section shows a graph of the Typical Transient Duration vs Comparator Overdrive.

In temperature monitoring, the voltage at V_{PTAT} must exceed a threshold for five consecutive temperature update intervals before the respective \overline{TO} pin is pulled low. Once the V_{PTAT} voltage crosses back the threshold with an additional 20mV of hysteresis, the respective \overline{TO} pin is released after a single update interval and an additional delay adjustable by the capacitor on TMR.

APPLICATIONS INFORMATION

Timing of Alert Outputs

The LTC2995 has an adjustable timeout period (t_{UOTO}) that holds \overline{UV} , \overline{OV} , $\overline{TO1}$ or $\overline{TO2}$ asserted after any faults have cleared. This delay will minimize the effect of input noise with a frequency above $1/t_{UOTO}$.

A voltage monitoring example: When any V_H drops below its threshold, the \overline{UV} pin asserts low. When all V_H inputs recover above their thresholds, the output timer starts. If all inputs remain above their thresholds when the timer finishes, the \overline{UV} pin weakly pulls high. However, if any input falls below its threshold during this timeout period, the timer resets and restarts when all inputs are again above the thresholds.

A temperature monitoring example: Tying PS to V_{CC} configures $\overline{TO2}$ as overtemperature output. In case of an overtemperature condition pin $\overline{TO2}$ asserts low. The output timer starts when the temperature crosses back below the threshold minus the temperature hysteresis. If the temperature remains below the threshold, the timer finishes and pin $\overline{TO2}$ releases high.

Selecting the Timing Capacitor

The timeout period (t_{UOTO}) for the LTC2995 is adjustable in order to accommodate a variety of applications. Connecting a capacitor, C_{TMR} , between the TMR pin and ground sets the timeout period. The value of capacitor needed for a particular timeout period is:

$$C_{TMR} = \frac{t_{UOTO} - 0.5\text{ms}}{8[\text{ms} / \text{nF}]}$$

The Reset Timeout Period vs Capacitance graph found in the Typical Performance Characteristics section shows the desired delay time as a function of the value of the timer capacitor that should be used. Leaving the TMR pin open with no external capacitor generates a timeout period of approximately 500 μ s. For long timeout periods, the only limitation is the availability of a large value capacitor with low leakage. Capacitor leakage current must not exceed the minimum TMR charging current of 1.5 μ A.

Tying the TMR pin to V_{CC} will bypass the timeout period and no delay will occur.

Digital Output Characteristics

The DC characteristics of the \overline{UV} , \overline{OV} , $\overline{TO1}$ and $\overline{TO2}$ pull-up and pull-down strength are shown in the Typical Performance Characteristics section. Each pin has a weak 400k Ω internal pull-up to V_{CC} and a strong pull-down to ground and can be pulled above V_{CC} .

This arrangement allows these pins to have open-drain behavior while possessing several other beneficial characteristics. The weak pull-up eliminates the need for an external pull-up resistor when the rise time on the pin is not critical. On the other hand, the open drain configuration allows for wired-OR connections and can be useful when more than one signal needs to pull-down on the output.

At $V_{CC} = 1\text{V}$, the weak pull-up current is barely turned on. Therefore, an external pull-up resistor of no more than 100k is recommended on the pin if the state and pull-up strength of the pin is crucial at very low V_{CC} .

Note however, by adding an external pull-up resistor, the pull-up strength on the pin is increased. Therefore, if it is connected in a wired-OR connection, the pull-down strength of any single device needs to accommodate this additional pull-up strength.

Output Rise and Fall Time Estimation

The \overline{UV} , \overline{OV} , $\overline{TO1}$ and $\overline{TO2}$ outputs have strong pull-down capability. The following formula estimates the output fall time (90% to 10%) for a particular external load capacitance (C_{LOAD}):

$$t_{FALL} \approx 2.2 \cdot R_{PD} \cdot C_{LOAD}$$

where R_{PD} is the on-resistance of the internal pull-down transistor estimated to be typically 40 Ω at $V_{DD} > 1\text{V}$ and at room temperature (25 $^{\circ}\text{C}$), and C_{LOAD} is the external load capacitance on the pin. Assuming a 150pF load capacitance, the fall time is about 13ns. The rise time on the \overline{UV} , \overline{OV} , $\overline{TO1}$ and $\overline{TO2}$ pins is limited by a 400k pull-up resistance to V_{DD} . A similar formula estimates the output rise time (10% to 90%):

$$t_{RISE} \approx 2.2 \cdot R_{PU} \cdot C_{LOAD}$$

where R_{PU} is the pull-up resistance.

TYPICAL APPLICATIONS

±10% Voltage Monitor (1.8V and 2.5V) and Internal/Remote Overtemperature Monitor

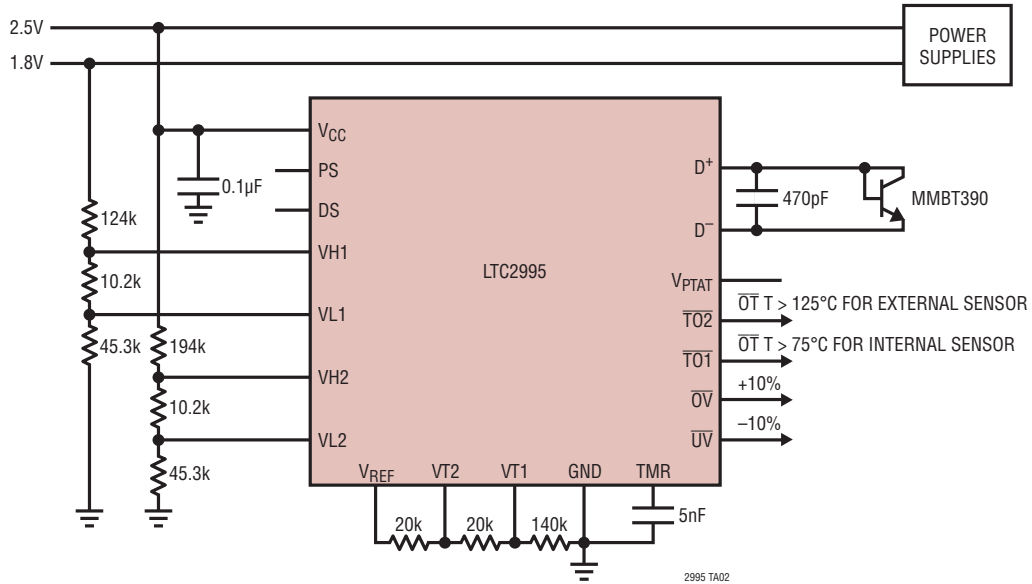

±20% Voltage Monitor (12V and 5V) and 0°C to 70°C Internal UT/OT Monitoring with Common Temperature and Powergood LED

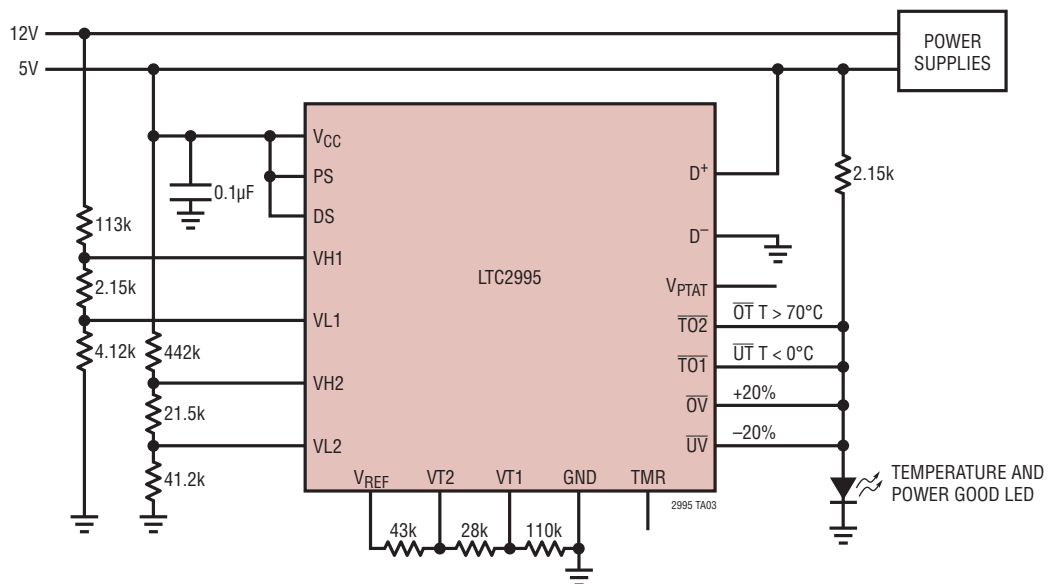

TYPICAL APPLICATIONS

Celsius Thermometer and $\pm 10\%$ Voltage Monitor (1.8V and 2.5V)

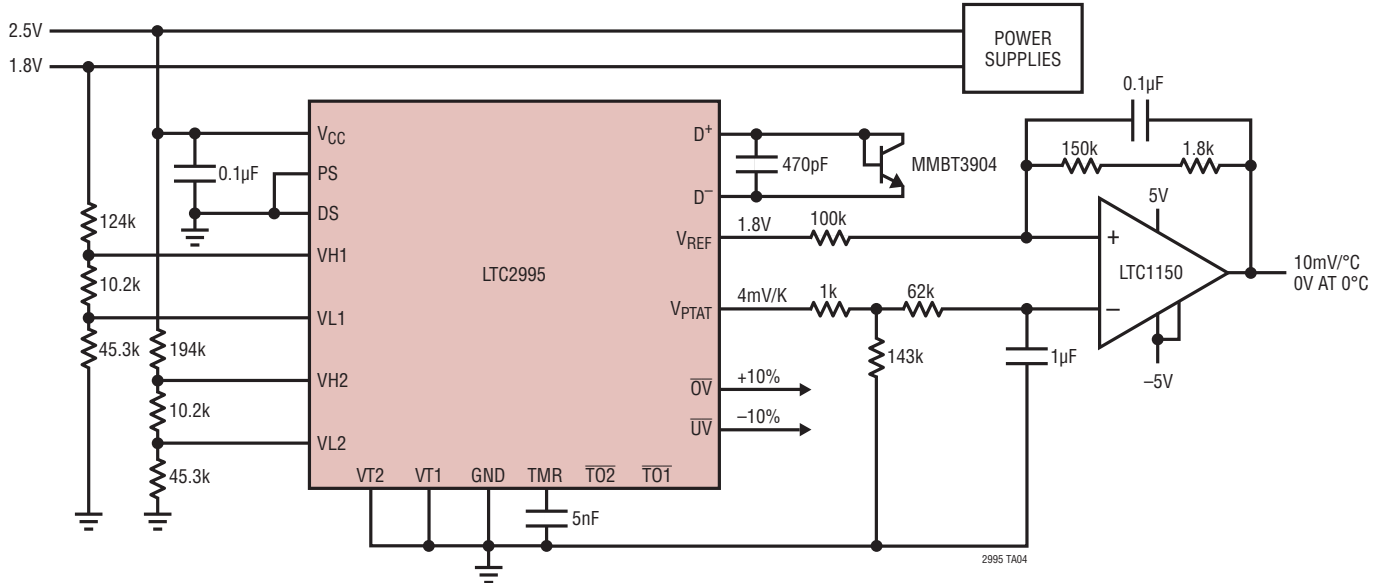

$\pm 10\%$ Voltage Monitor (12V and 5V) and -20°C to 70°C Internal UT/OT Monitor with Manual Undervoltage Reset Button

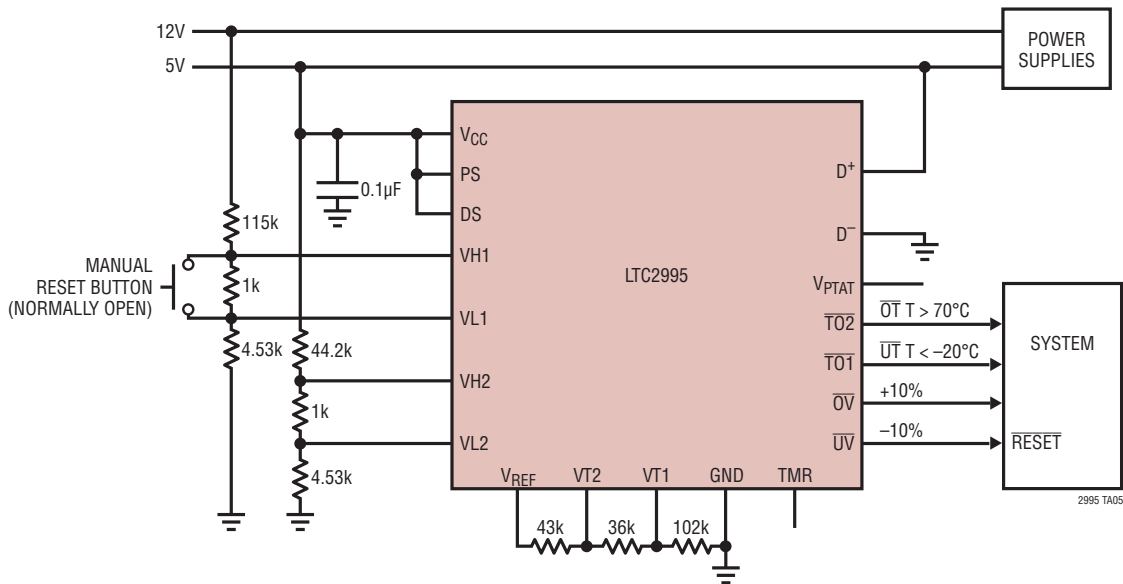

PACKAGE DESCRIPTION

Please refer to <http://www.linear.com/designtools/packaging/> for the most recent package drawings.

UD Package 20-Lead Plastic QFN (3mm × 3mm) (Reference LTC DWG # 05-08-1720 Rev A)

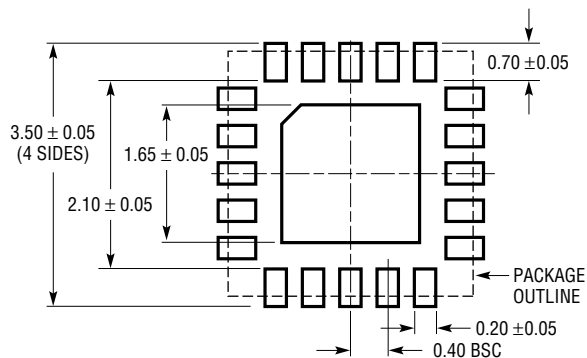

RECOMMENDED SOLDER PAD PITCH AND DIMENSIONS
APPLY SOLDER MASK TO AREAS THAT ARE NOT SOLDERED

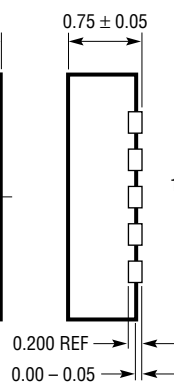
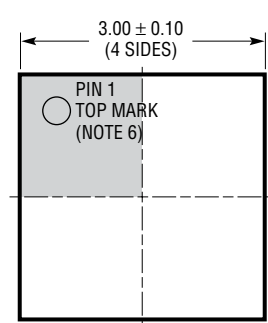

BOTTOM VIEW—EXPOSED PAD

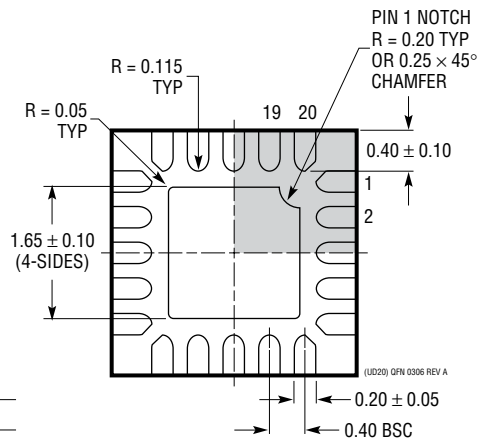

NOTE:

1. DRAWING IS NOT A JEDEC PACKAGE OUTLINE
2. DRAWING NOT TO SCALE
3. ALL DIMENSIONS ARE IN MILLIMETERS
4. DIMENSIONS OF EXPOSED PAD ON BOTTOM OF PACKAGE DO NOT INCLUDE MOLD FLASH. MOLD FLASH, IF PRESENT, SHALL NOT EXCEED 0.15mm ON ANY SIDE
5. EXPOSED PAD SHALL BE SOLDER PLATED
6. SHADED AREA IS ONLY A REFERENCE FOR PIN 1 LOCATION ON THE TOP AND BOTTOM OF PACKAGE

TYPICAL APPLICATION

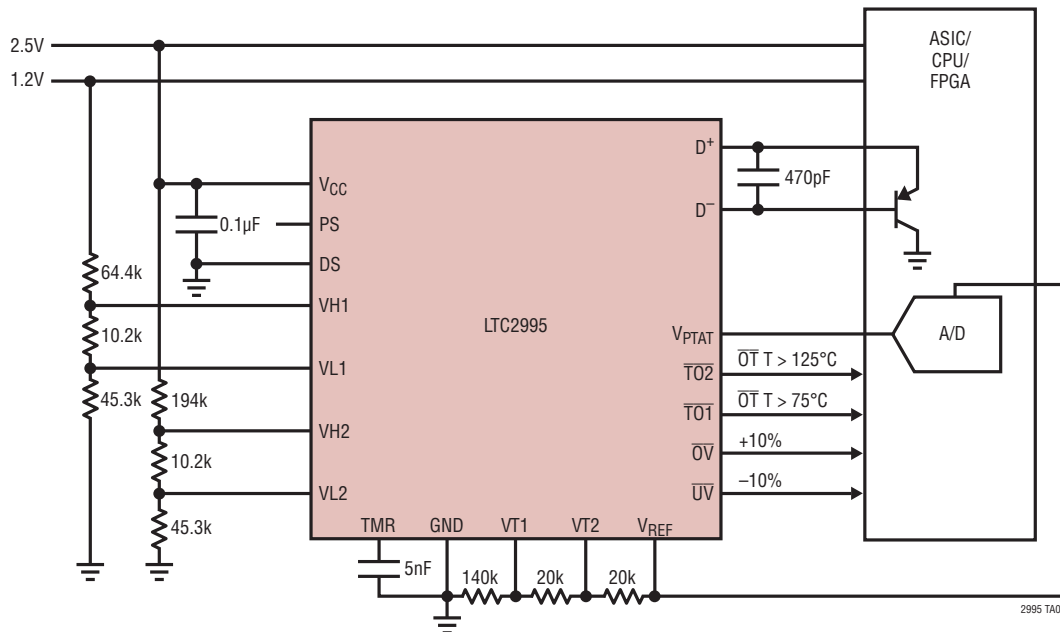
Dual OV/UV $\pm 10\%$ Supply and 75°C/125°C OT/OT Remote Temperature Monitor

RELATED PARTS

PART NUMBER	DESCRIPTION	COMMENTS
LTC2990	Remote/Internal Temperature, Voltage, Current Monitor	I ² C Interface
LTC2991	Remote/Internal Temperature Sensor	I ² C Interface, Eight Single-Ended Inputs
LTC2997	Remote/Internal Temperature Sensor	Analog V _{PTAT} Output Voltage
LTC2900	Programmable Quad Supply Monitor	Adjustable $\overline{\text{RESET}}$, 10-Lead MSOP and 3mm × 3mm 10-Lead DFN
LTC2901	Programmable Quad Supply Monitor	Adjustable $\overline{\text{RESET}}$ and Watchdog Timer, 16-Lead SSOP Package
LTC2902	Programmable Quad Supply Monitor	Adjustable $\overline{\text{RESET}}$ and Tolerance, 16-Lead SSOP Package, Margining Functions
LTC2903	Precision Quad Supply Monitor	6-Lead SOT-23 Package, Ultralow Voltage Reset
LTC2904	3-State Programmable Precision Dual Supply Monitor	Adjustable Tolerance, 8-Lead SOT-23 Package
LTC2905	3-State Programmable Precision Dual Supply Monitor	Adjustable $\overline{\text{RESET}}$ and Tolerance, 8-Lead SOT-23 Package
LTC2906	Precision Dual Supply Monitor 1-Selectable and One Adjustable	Separate V _{CC} Pin, RST/ $\overline{\text{RST}}$ Outputs
LTC2907	Precision Dual Supply Monitor 1-Selectable and One Adjustable	Separate V _{CC} , Adjustable Reset Timer
LTC2908	Precision Six Supply Monitor (Four Fixed and Two Adjustable)	8-Lead SOT-23 and DDB Packages
LTC2909	Precision Dual Input UV, OV and Negative Voltage Monitor	2 ADJ Inputs, Monitors Negative Voltages
LTC2912	Single UV/OV Positive Voltage Monitor	Separate V _{CC} Pin, 8-Lead TSOT and 3mm × 2mm DFN Packages
LTC2913	Dual UV/OV Positive Voltage Monitor	Separate V _{CC} Pin, 10-Lead MSOP and 3mm × 3mm DFN Packages
LTC2914	Quad UV/OV Positive/Negative Voltage Monitor	Separate V _{CC} Pin, 16-Lead SSOP and 5mm × 2mm DFN Packages

Looking for pricing, stock, or lifecycle information?

Click below to explore more details on WIN SOURCE:

 [View LTC2995CUD#PBF on WIN SOURCE](#)

 [Linear Technology](#) Information

Optimize Your Supply Chain with WIN SOURCE Solutions

-  Global Sourcing Solution
-  Obsolete Management
-  Cost Control Management
-  Shortage Management
-  Alternative Solution
-  Excess Inventory Management