



**THE DATASHEET OF
LTC2473CMS#PBF**



FEATURES

- 16-Bit Resolution
- Internal, High Accuracy Reference—10ppm/°C (Max)
- Single-Ended (LTC2471) or Differential (LTC2473)
- Selectable 208sps/833sps Output Rate
- 1mV Offset Error
- 0.01% Gain Error
- Single Conversion Settling Time Simplifies Multiplexed Applications
- Single-Cycle Operation with Auto Shutdown
- 3.5mA (Typ) Supply Current
- 2μA (Max) Sleep Current
- Internal Oscillator—No External Components Required
- I²C Interface
- Small 12-Lead, 3mm × 3mm DFN and MSOP Packages

APPLICATIONS

- System Monitoring
- Environmental Monitoring
- Direct Temperature Measurements
- Instrumentation
- Industrial Process Control
- Data Acquisition
- Embedded ADC Upgrades

LT, LT, LTC, LTM, Linear Technology and the Linear logo are registered trademarks of Linear Technology Corporation and Easy Drive and No Latency ΔΣ is a trademark of Linear Technology Corporation. All other trademarks are the property of their respective owners. Protected by U.S. Patents, including 6208279, 6411242, 7088280, 7164378.

DESCRIPTION

The LTC[®]2471/LTC2473 are small, 16-bit analog-to-digital converters with an integrated precision reference and a selectable 208sps or 833sps output rate. They use a single 2.7V to 5.5V supply and communicate through an I²C Interface. The LTC2471 is single-ended with a 0V to V_{REF} input range and the LTC2473 is differential with a ±V_{REF} input range. Both ADCs include a 1.25V integrated reference with 2ppm/°C drift performance and 0.1% initial accuracy. The converters are available in a 12-pin DFN 3mm × 3mm package or an MSOP-12 package. They include an integrated oscillator and perform conversions with no latency for multiplexed applications. The LTC2471/LTC2473 include a proprietary input sampling scheme that reduces the average input current several orders of magnitude when compared to conventional delta sigma converters.

Following a single conversion, the LTC2471/LTC2473 automatically power down the converter and can also be configured to power down the reference. When both the ADC and reference are powered down, the supply current is reduced to 200nA.

The LTC2471/LTC2473 include a user selectable 208sps or 833sps output rate and due to a large oversampling ratio (8,192 at 208sps and 2,048 at 833sps) have relaxed anti-aliasing requirements.

TYPICAL APPLICATION

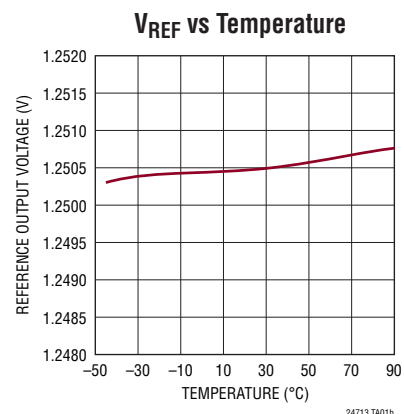
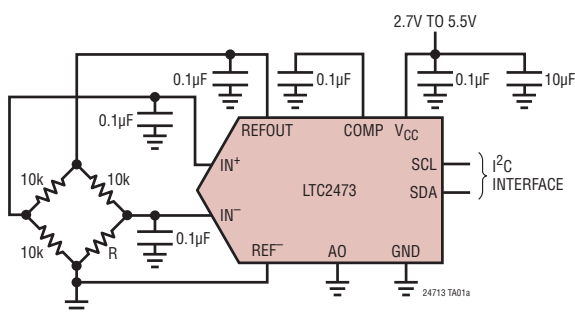

LTC2471/LTC2473

ABSOLUTE MAXIMUM RATINGS (Notes 1, 2)

Supply Voltage (V_{CC})	-0.3V to 6V	Storage Temperature Range	-65°C to 150°C
Analog Input Voltage (V_{IN}^+ , V_{IN}^- , V_{IN} , V_{REF}^- , V_{COMP} , V_{REFOUT})	-0.3V to ($V_{CC} + 0.3V$)	Operating Temperature Range	
Digital Voltage (V_{SDA} , V_{SCL} , V_{AO})	-0.3V to ($V_{CC} + 0.3V$)	LTC2471C/LTC2473C	0°C to 70°C
		LTC2471I/LTC2473I	-40°C to 85°C

PIN CONFIGURATION

<p>LTC2473</p> <p style="text-align: center;">TOP VIEW</p> <p>REFOUT 1 COMP 2 AO 3 GND 4 SCL 5 SDA 6</p> <p style="text-align: center;">13 GND</p> <p>V_{CC} 12 GND 11 IN⁻ 10 IN⁺ 9 REF⁻ 8 GND 7</p> <p>DD PACKAGE 12-LEAD (3mm × 3mm) PLASTIC DFN T_{JMAX} = 125°C, θ_{JA} = 43°C/W EXPOSED PAD (PIN 13) PCB GROUND CONNECTION</p>	<p>LTC2473</p> <p style="text-align: center;">TOP VIEW</p> <p>REFOUT 1 COMP 2 AO 3 GND 4 SCL 5 SDA 6</p> <p>12 V_{CC} 11 GND 10 IN⁻ 9 IN⁺ 8 REF⁻ 7 GND</p> <p>MS PACKAGE 12-LEAD PLASTIC MSOP T_{JMAX} = 125°C, θ_{JA} = 130°C/W</p>
<p>LTC2471</p> <p style="text-align: center;">TOP VIEW</p> <p>REFOUT 1 COMP 2 AO 3 GND 4 SCL 5 SDA 6</p> <p style="text-align: center;">13 GND</p> <p>V_{CC} 12 GND 11 GND 10 IN 9 REF⁻ 8 GND 7</p> <p>DD PACKAGE 12-LEAD (3mm × 3mm) PLASTIC DFN T_{JMAX} = 125°C, θ_{JA} = 43°C/W EXPOSED PAD (PIN 13) PCB GROUND CONNECTION</p>	<p>LTC2471</p> <p style="text-align: center;">TOP VIEW</p> <p>REFOUT 1 COMP 2 AO 3 GND 4 SCL 5 SDA 6</p> <p>12 V_{CC} 11 GND 10 GND 9 IN 8 REF⁻ 7 GND</p> <p>MS PACKAGE 12-LEAD PLASTIC MSOP T_{JMAX} = 125°C, θ_{JA} = 130°C/W</p>

ORDER INFORMATION

LEAD FREE FINISH	TAPE AND REEL	PART MARKING*	PACKAGE DESCRIPTION	TEMPERATURE RANGE
LTC2471CDD#PBF	LTC2471CDD#TRPBF	LFPW	12-Lead Plastic (3mm × 3mm) DFN	0°C to 70°C
LTC2471IDD#PBF	LTC2471IDD#TRPBF	LFPW	12-Lead Plastic (3mm × 3mm) DFN	-40°C to 85°C
LTC2471CMS#PBF	LTC2471CMS#TRPBF	2471	12-Lead Plastic MSOP	0°C to 70°C
LTC2471IMS#PBF	LTC2471IMS#TRPBF	2471	12-Lead Plastic MSOP	-40°C to 85°C
LTC2473CDD#PBF	LTC2473CDD#TRPBF	LFPX	12-Lead Plastic (3mm × 3mm) DFN	0°C to 70°C
LTC2473IDD#PBF	LTC2473IDD#TRPBF	LFPX	12-Lead Plastic (3mm × 3mm) DFN	-40°C to 85°C
LTC2473CMS#PBF	LTC2473CMS#TRPBF	2473	12-Lead Plastic MSOP	0°C to 70°C
LTC2473IMS#PBF	LTC2473IMS#TRPBF	2473	12-Lead Plastic MSOP	-40°C to 85°C

Consult LTC Marketing for parts specified with wider operating temperature ranges. *The temperature grade is identified by a label on the shipping container. Consult LTC Marketing for information on non-standard lead based finish parts.

For more information on lead free part marking, go to: <http://www.linear.com/leadfree/>

For more information on tape and reel specifications, go to: <http://www.linear.com/tapeandreeel/>

ELECTRICAL CHARACTERISTICS

The ● denotes the specifications which apply over the full operating temperature range, otherwise specifications are at $T_A = 25^\circ\text{C}$. (Note 2)

PARAMETER	CONDITIONS	MIN	TYP	MAX	UNITS
Resolution			16		Bits
Integral Nonlinearity	Output Rate 208sps (Note 4)	●	2	8.5	LSB
	Output Rate 833sps (Note 4)	●	8	16	LSB
Offset Error		●	± 1	± 2.5	mV
Offset Error Drift			0.05		LSB/ $^\circ\text{C}$
Gain Error		●	± 0.01	± 0.25	% of FS
Gain Error Drift		●	0.15		LSB/ $^\circ\text{C}$
Transition Noise			3		μV_{RMS}
Power Supply Rejection DC			80		dB

ANALOG INPUTS

The ● denotes the specifications which apply over the full operating temperature range, otherwise specifications are at $T_A = 25^\circ\text{C}$.

SYMBOL	PARAMETER	CONDITIONS	MIN	TYP	MAX	UNITS	
V_{IN}^+	Positive Input Voltage Range	LTC2473	●	0	V_{REF}	V	
V_{IN}^-	Negative Input Voltage Range	LTC2473	●	0	V_{REF}	V	
V_{IN}	Input Voltage Range	LTC2471	●	0	V_{REF}	V	
$V_{\text{OR}}^+, V_{\text{UR}}^+$	Overrange/Underrange Voltage, IN^+	$V_{\text{IN}}^- = 0.625\text{V}$		8		LSB	
$V_{\text{OR}}^-, V_{\text{UR}}^-$	Overrange/Underrange Voltage, IN^-	$V_{\text{IN}}^+ = 0.625\text{V}$		8		LSB	
C_{IN}	$\text{IN}^+, \text{IN}^-, \text{IN}$ Sampling Capacitance			0.35		pF	
$I_{\text{DC_LEAK}}(\text{IN}^+, \text{IN}^-, \text{IN})$	IN^+, IN^- DC Leakage Current (LTC2473) IN DC Leakage Current (LTC2471)	$V_{\text{IN}} = \text{GND}$ (Note 8)	●	-10	± 1	10	nA
		$V_{\text{IN}} = V_{\text{CC}}$ (Note 8)	●	-10	± 1	10	nA
I_{CONV}	Input Sampling Current (Notes 5, 8)			50		nA	
V_{REF}	Reference Output Voltage		●	1.247	1.25	1.253	V
	Reference Voltage Coefficient	(Note 9) C-Grade I-Grade	●		± 2 ± 5	± 10	ppm/ $^\circ\text{C}$ ppm/ $^\circ\text{C}$
	Reference Line Regulation	$2.7\text{V} \leq V_{\text{CC}} \leq 5.5\text{V}$		-90			dB
	Reference Short-Circuit Current	$V_{\text{CC}} = 5.5$, Forcing Output to GND (Note 8)	●			35	mA
	COMP Pin Short-Circuit Current	$V_{\text{CC}} = 5.5$, Forcing Output to GND (Note 8)	●			200	μA
	Reference Load Regulation	$2.7\text{V} \leq V_{\text{CC}} \leq 5.5\text{V}$, $I_{\text{OUT}} = 100\mu\text{A}$ Sourcing			3.5		mV/mA
	Reference Output Noise Density	$C_{\text{COMP}} = 0.1\mu\text{F}$, $C_{\text{REFOUT}} = 0.1\mu\text{F}$, At $f = 1\text{ksps}$			30		$\text{nV}/\sqrt{\text{Hz}}$

POWER REQUIREMENTS

The ● denotes the specifications which apply over the full operating temperature range, otherwise specifications are at $T_A = 25^\circ\text{C}$.

SYMBOL	PARAMETER	CONDITIONS	MIN	TYP	MAX	UNITS	
V_{CC}	Supply Voltage		●	2.7	5.5	V	
I_{CC}	Supply Current	Conversion	●		3.5	5	mA
		Conversion	●		2.5	4	mA
		Nap	●		800	1500	μA
		Sleep	●		0.2	2	μA

I²C INPUTS AND OUTPUTS

The ● denotes the specifications which apply over the full operating temperature range, otherwise specifications are at T_A = 25°C. (Notes 2, 7)

SYMBOL	PARAMETER	CONDITIONS	MIN	TYP	MAX	UNITS
V _{IH}	High Level Input Voltage		● 0.7V _{CC}			V
V _{IL}	Low Level Input Voltage				● 0.3V _{CC}	V
I _I	Digital Input Current	(Note 8)	● -10		● 10	μA
V _{HYS}	Hysteresis of Schmidt Trigger Inputs	(Note 3)	● 0.05V _{CC}			V
V _{OL}	Low Level Output Voltage (SDA)	I = 3mA			● 0.4	V
I _{IN}	Input Leakage	0.1V _{CC} ≤ V _{IN} ≤ 0.9V _{CC}			● 1	μA
C _I	Capacitance for Each I/O Pin		● 10			pF
C _B	Capacitance Load for Each Bus Line				● 400	pF
V _{IH(A0)}	High Level Input Voltage for Address Pin		● 0.95V _{CC}			V
V _{IL(A0)}	Low Level Input Voltage for Address Pin				● 0.05V _{CC}	V

I²C TIMING CHARACTERISTICS

The ● denotes the specifications which apply over the full operating temperature range, otherwise specifications are at T_A = 25°C. (Notes 2, 7)

SYMBOL	PARAMETER	CONDITIONS	MIN	TYP	MAX	UNITS
t _{CONV1}	Conversion Time	SPD = 0		● 4	● 4.8	ms
t _{CONV2}	Conversion Time	SPD = 1		● 1	● 1.2	ms
f _{SCL}	SCL Clock Frequency		● 0		● 400	kHz
t _{HD(SDA,STA)}	Hold Time (Repeated) START Condition		● 0.6			μs
t _{LOW}	LOW Period of the SCL Pin		● 1.3			μs
t _{HIGH}	HIGH Period of the SCL Pin		● 0.6			μs
t _{SU(STA)}	Set-Up Time for a Repeated START Condition		● 0.6			μs
t _{HD(DAT)}	Data Hold Time		● 0		● 0.9	μs
t _{SU(DAT)}	Data Set-Up Time		● 100			ns
t _r	Rise Time for SDA, SCL Signals	(Note 6)	● 20 + 0.1C _B		● 300	ns
t _f	Fall Time for SDA, SCL Signals	(Note 6)	● 20 + 0.1C _B		● 300	ns
t _{SU(STO)}	Set-Up Time for STOP Condition		● 0.6			μs
t _{BUF}	Bus Free Time Between a STOP and START Condition		● 1.3			μs
t _{OF}	Output Fall Time V _{IHMIN} to V _{ILMAX}	Bus Load C _B = 10pF to 400pF (Note 6)	● 20 + 0.1C _B		● 250	ns
t _{SP}	Input Spike Suppression				● 50	ns

Note 1: Stresses beyond those listed under Absolute Maximum Ratings may cause permanent damage to the device. Exposure to any Absolute Maximum Rating condition for extended periods may affect device reliability and lifetime.

Note 2: All voltage values are with respect to GND. V_{CC} = 2.7V to 5.5V unless otherwise specified.

$$V_{REFCM} = V_{REF}/2, FS = V_{REF}, -V_{REF} \leq V_{IN} \leq V_{REF}$$

$$V_{IN} = V_{IN+} - V_{IN-}, V_{INCM} = (V_{IN+} + V_{IN-})/2. (LTC2473)$$

Note 3: Guaranteed by design, not subject to test.

Note 4: Integral nonlinearity is defined as the deviation of a code from a straight line passing through the actual endpoints of the transfer curve.

Note 5: Input sampling current is the average input current drawn from the input sampling network while the LTC2471/LTC2473 are converting.

Note 6: C_B = capacitance of one bus line in pF.

Note 7: All values refer to V_{IH(MIN)} and V_{IL(MAX)} levels.

Note 8: A positive current is flowing into the DUT pin.

Note 9: Voltage temperature coefficient is calculated by dividing the maximum change in output voltage by the specified temperature range.

TYPICAL PERFORMANCE CHARACTERISTICS ($T_A = 25^\circ\text{C}$, unless otherwise noted)

Integral Nonlinearity

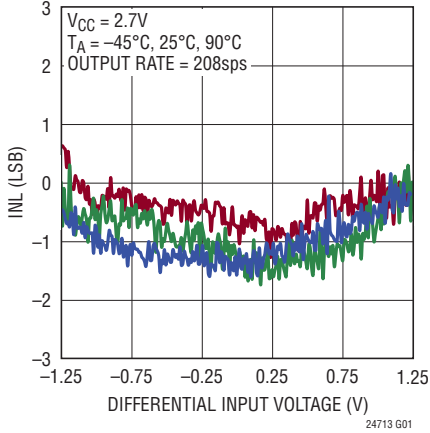

Integral Nonlinearity

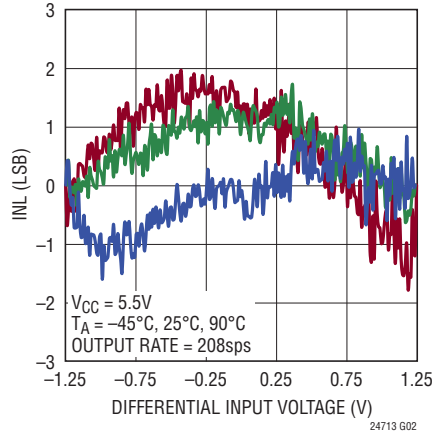

Maximum INL vs Temperature

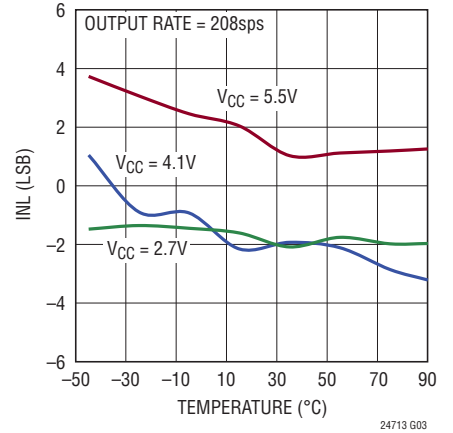

Offset Error vs Temperature

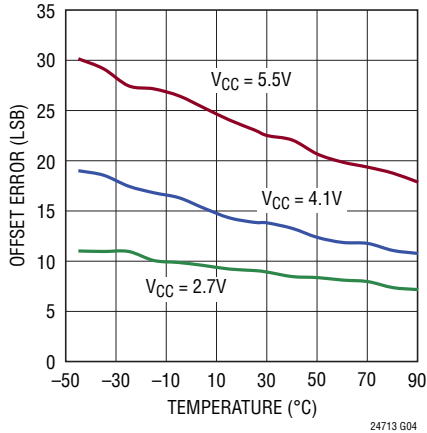

ADC Gain Error vs Temperature

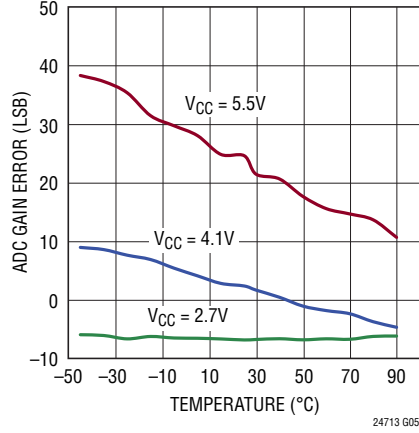

Transition Noise vs Temperature

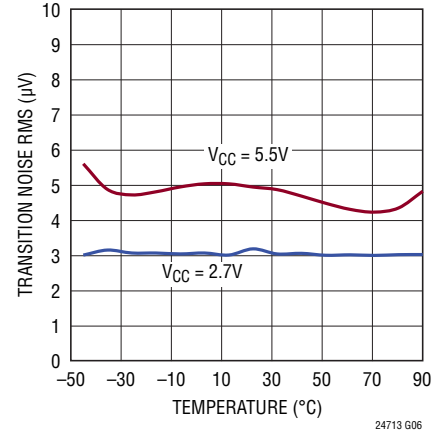

Conversion Mode Power Supply Current vs Temperature

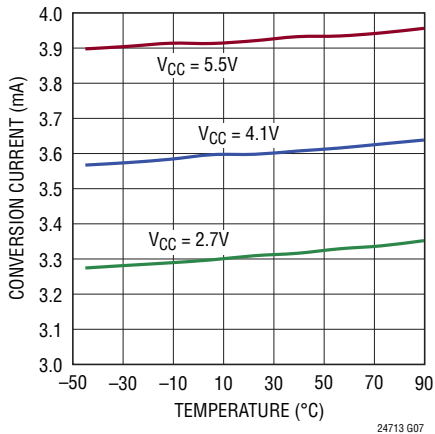

Sleep Mode Power Supply Current vs Temperature

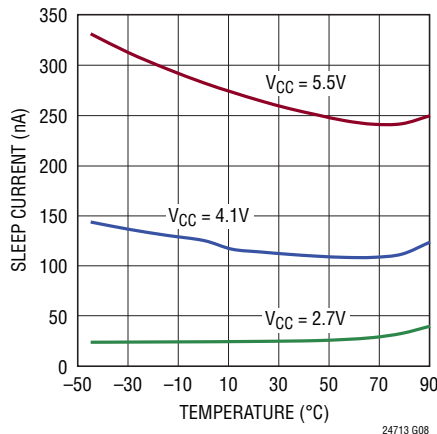

VREF vs Temperature

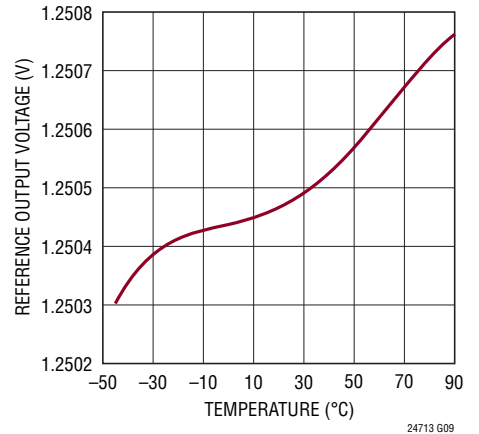

TYPICAL PERFORMANCE CHARACTERISTICS ($T_A = 25^\circ\text{C}$, unless otherwise noted)

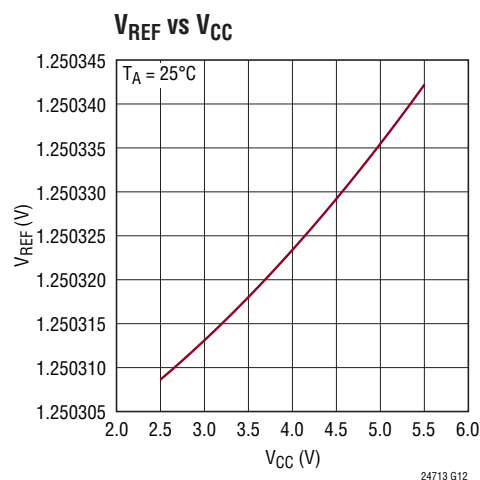
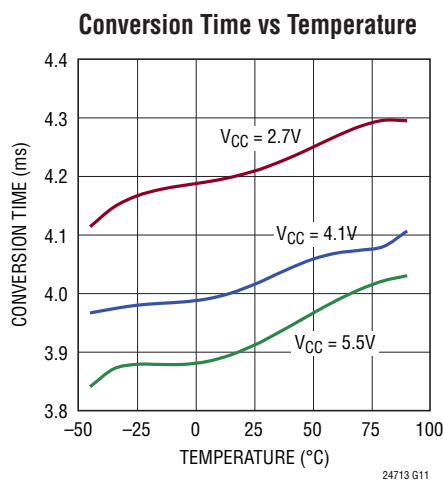
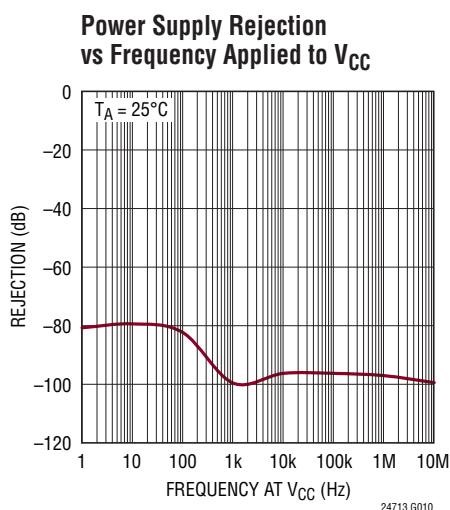

PIN FUNCTIONS

REFOUT (Pin 1): Reference Output Pin. Nominally 1.25V, this voltage sets the full-scale input range of the ADC. For noise and reference stability connect to a 0.1 μF capacitor tied to GND. This capacitor value must be less than or equal to the capacitor tied to the reference compensation pin (COMP). REFOUT must not be overdriven by an external reference.

COMP (Pin 2): Internal Reference Compensation Pin. For low noise and reference stability, tie a 0.1 μF capacitor to GND.

A0 (Pin 3): Chip Address Control Pin. The A0 pin can be tied to GND or V_{CC} . If A0 is tied to GND, the LTC2471/LTC2473 I²C address is 0010100. If A0 is tied to V_{CC} , the LTC2471/LTC2473 I²C address is 1010100.

GND (Pins 4, 7, 11, (Exposed Pad Pin 13 – DFN Package Only)): Ground. Connect exposed pad directly to the ground plane through a low impedance connection.

SCL (Pin 5): Serial Clock Input of the I²C Interface. The LTC2471/LTC2473 can only act as an I²C slave and the SCL pin only accepts an external serial clock. Data is shifted into the SDA pin on the rising edges of SCL and output through the SDA pin on the falling edges of SCL.

SDA (Pin 6): Bidirectional Serial Data Line of the I²C Interface. The conversion result is output through the SDA pin. The pin is high impedance unless the LTC2471/LTC2473 is in the data output mode. While the LTC2471/LTC2473 is in the data output mode, SDA is an open drain pull down (which requires an external 1.7k pull-up resistor to V_{CC}).

REF⁻ (Pin 8): Negative Reference Input to the ADC. The voltage on this pin sets the zero input to the ADC. This pin should tie directly to ground or the ground sense of the input sensor.

IN⁺ (LTC2473), IN (LTC2471) (Pin 9): Positive input voltage for the LTC2473 differential device. ADC input for the LTC2471 single-ended device.

IN⁻ (LTC2473), GND (LTC2471) (Pin 10): Negative input voltage for the LTC2473 differential device. GND for the LTC2471 single-ended device.

V_{CC} (Pin 12): Positive Supply Voltage. Bypass to GND with a 10 μF capacitor in parallel with a low-series-inductance 0.1 μF capacitor located as close to pin 12 as possible.

BLOCK DIAGRAM

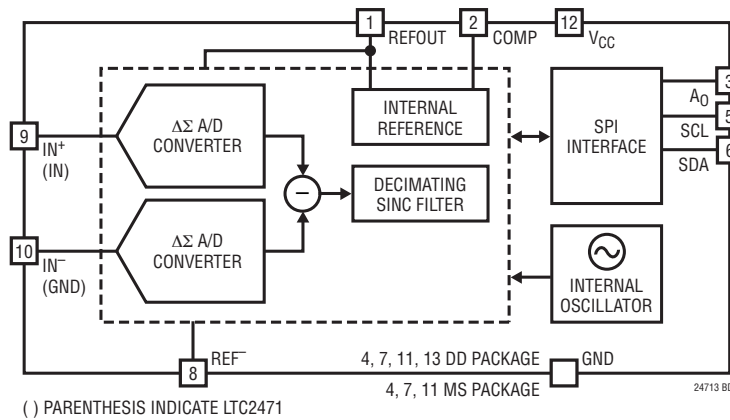

Figure 1. Functional Block Diagram

APPLICATIONS INFORMATION

CONVERTER OPERATION

Converter Operation Cycle

The LTC2471/LTC2473 are low power, delta sigma, analog to digital converters with a simple I²C interface and a user selected 208sps/833sps output rate (see Figure 1). The LTC2473 has a fully differential input while the LTC2471 is single-ended. Both are pin and software compatible. Their operation is composed of three distinct states: CONVERT, SLEEP/NAP, and DATA INPUT/OUTPUT. The operation begins with the CONVERT state (see Figure 2). Once the conversion is finished, the converter automatically powers down (NAP) or under user control, both the converter and reference are powered down (SLEEP). The conversion result is held in a static register while the device is in this state. The cycle concludes with the DATA INPUT/OUTPUT state. Once all 16-bits are read or an abort is initiated, the device begins a new conversion.

The CONVERT state duration is determined by the LTC2471/LTC2473 conversion time (nominally 4.8ms or 1.2ms depending on the selected output rate). Once started, this operation can not be aborted except by a low power supply condition ($V_{CC} < 2.1V$) which generates an internal power-on reset signal.

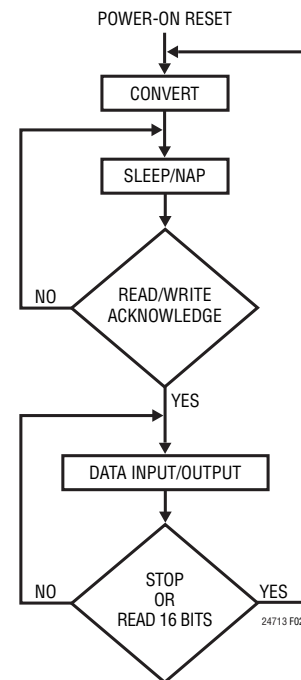

Figure 2. LTC2471/LTC2473 State Transition Diagram

APPLICATIONS INFORMATION

After the completion of a conversion, the LTC2471/LTC2473 enters the SLEEP/NAP state and remains there until a valid read/write is acknowledged. Following this condition, the ADC transitions into the DATA INPUT/OUTPUT state.

While in the SLEEP/NAP state, the LTC2471/LTC2473's converters are powered down. This reduces the supply current by approximately 70%. While in the NAP state the reference remains powered up. The user can power down both the reference and the converter by enabling the sleep mode during the DATA INPUT/OUTPUT state. Once the next conversion is complete with the sleep mode enabled, the SLEEP state is entered and power is reduced to 2 μ A (maximum). The reference is powered up once a valid read/write is acknowledged. The reference startup time is 12ms (if the reference and compensation capacitor values are both 0.1 μ F). As the reference and compensation capacitors are decreased, the startup time is reduced (see Figure 3), but the transition noise increases (see Figure 4).

Power-Up Sequence

When the power supply voltage (V_{CC}) applied to the converter is below approximately 2.1V, the ADC performs a power-on reset. This feature guarantees the integrity of the conversion result.

When V_{CC} rises above this critical threshold, the converter generates an internal power-on reset (POR) signal for approximately 0.5ms. For proper operation V_{DD} needs to be restored to normal operating range (2.7V to 5.5V) before the conclusion of the POR cycle. The POR signal clears all internal registers. Following the POR signal, the LTC2471/LTC2473 start a conversion cycle and follow the succession of states shown in Figure 2. The reference startup time following a POR is 12ms ($C_{COMP} = C_{REFOUT} = 0.1\mu$ F). The first conversion following power-up will be invalid if the reference voltage has not completely settled (see Figure 3). The first conversion following power up can be discarded using the data abort command or simply read and ignored. Depending on the value chosen for C_{COMP} and C_{REFOUT} , the reference startup can take more than one conversion period, see Figure 3. If the startup time is less than 1.2ms (833sps output rate) or 4.8ms (208sps output rate) then conversions following the first period are accurate to the device specifications. If the startup time exceeds 1.2ms or 4.8ms then the user can wait the appropriate time or use the fixed conversion period as a startup timer by ignoring results within the unsettled period. Once the reference has settled, all subsequent conversion results are valid. If the user places the device into the sleep mode ($SLP = 1$, reference powered down) the reference will require a startup time proportional to the value of C_{COMP} and C_{REFOUT} (see Figure 3).

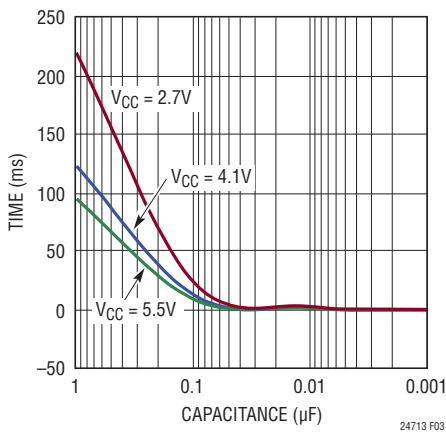

Figure 3. Reference Start-Up Time vs V_{REF} and Compensation Capacitance

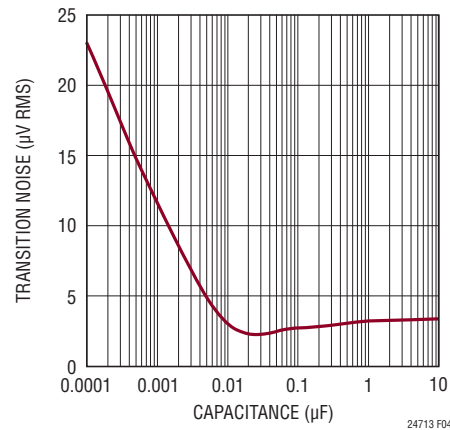

Figure 4. Transition Noise RMS vs COMP and Reference Capacitance

APPLICATIONS INFORMATION

Ease of Use

The LTC2471/LTC2473 data output has no latency, filter settling delay, or redundant results associated with the conversion cycle. There is a one-to-one correspondence between the conversion and the output data. Therefore, multiplexing multiple analog input voltages requires no special actions.

The LTC2471/LTC2473 include a proprietary input sampling scheme that reduces the average input current by several orders of magnitude when compared to traditional delta-sigma architectures. This allows external filter networks to interface directly to the LTC2471/LTC2473. Since the average input sampling current is 50nA, an external RC lowpass filter using 1k Ω and 0.1 μ F results in <1LSB additional error. Additionally, there is negligible leakage current between IN⁺ and IN⁻ (for the LTC2473).

Input Voltage Range (LTC2471)

Ignoring offset and full-scale errors, the LTC2471 will theoretically output an “all zero” digital result when the input is at ground (a zero scale input) and an “all one” digital result when the input is at V_{REF} or higher (V_{REFOUT} = 1.25V). In an underrange condition (for all input voltages below zero scale) the converter will generate the output code 0. In an overrange condition (for all input voltages greater than V_{REF}) the converter will generate the output code 65535.

Input Voltage Range (LTC2473)

As detailed in the Output Data Format section, the output code is given as $INT(32767.5 \cdot (V_{IN^+} - V_{IN^-}) / V_{REF} + 32767.5)$. For $(V_{IN^+} - V_{IN^-}) \geq V_{REF}$, the output code is clamped at 65535 (all ones). For $(V_{IN^+} - V_{IN^-}) \leq -V_{REF}$, the output code is clamped at 0 (all zeroes).

I²C INTERFACE

The LTC2471/LTC2473 communicate through an I²C interface. The I²C interface is a 2-wire open-drain interface supporting multiple devices and masters on a single bus. The connected devices can only pull the data line (SDA) LOW and can never drive it HIGH. SDA must be externally connected to the supply through a pull-up resistor. When the data line is free, it is HIGH. Data on the I²C bus can be transferred at rates up to 100kbits/s in the standard mode and up to 400kbits/s in the fast mode.

Upon entering the DATA INPUT/OUTPUT state, SDA outputs the sign (D15) of the conversion result. During this state, the ADC shifts the conversion result serially through the SDA output pin under the control of the SCL input pin. There is no latency in generating this data and the result corresponds to the last completed conversion. A new bit of data appears at the SDA pin following each falling edge detected at the SCL input pin and appears from MSB to LSB. The user can reliably latch this data on every rising edge of the external serial clock signal driving the SCL pin.

Each device on the I²C bus is recognized by a unique address stored in that device and can operate either as a transmitter or receiver, depending on the function of the device. In addition to transmitters and receivers, devices can also be considered as masters or slaves when performing data transfers. A master is the device which initiates a data transfer on the bus and generates the clock signals to permit that transfer. Devices addressed by the master are considered a slave. The address of the LTC2471/LTC2473 is 0010100 (if A0 is tied to GND) or 1010100 (if A0 is tied to V_{CC}).

APPLICATIONS INFORMATION

The LTC2471/LTC2473 can only be addressed as a slave. It can only transmit the last conversion result. The serial clock line, SCL, is always an input to the LTC2471/LTC2473 and the serial data line SDA is bidirectional. Figure 5 shows the definition of the I²C timing.

The START and STOP Conditions

A START (S) condition is generated by transitioning SDA from HIGH to LOW while SCL is HIGH. The bus is considered to be busy after the START condition. When the data transfer is finished, a STOP (P) condition is generated by transitioning SDA from LOW to HIGH while SCL is HIGH. The bus is free after a STOP is generated. START and STOP conditions are always generated by the master.

When the bus is in use, it stays busy if a repeated START (Sr) is generated instead of a STOP condition. The repeated START timing is functionally identical to the START and is used for reading from the device before the initiation of a new conversion.

Data Transferring

After the START condition, the I²C bus is busy and data transfer can begin between the master and the addressed slave. Data is transferred over the bus in groups of nine bits, one byte followed by one acknowledge (ACK) bit. The master releases the SDA line during the ninth SCL clock cycle. The slave device can issue an ACK by pulling SDA LOW or issue a Not Acknowledge (NACK) by leaving the SDA line HIGH impedance (the external pull-up resistor will hold the line HIGH). Change of data only occurs while the clock line (SCL) is LOW.

Output Data Format

After a START condition, the master sends a 7-bit address followed by a read request (R) bit. The bit R is 1 for a Read Request. If the 7-bit address matches the LTC2471/LTC2473's address (0010100 or 1010100, depending on the state of the pin A0) the ADC is selected. When the device is addressed during the conversion state, it does

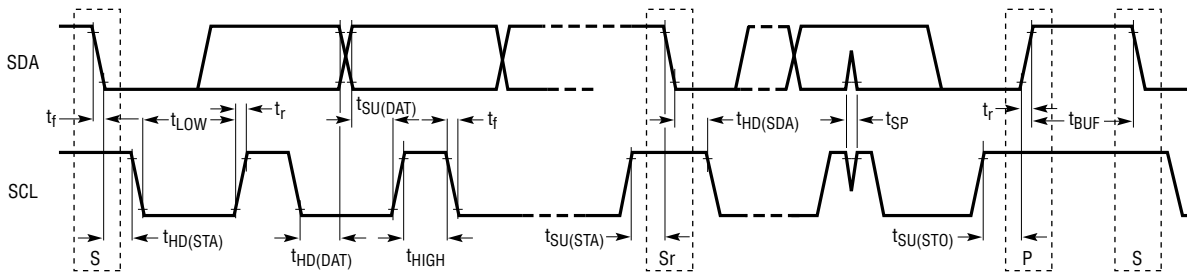

24713 F05

Figure 5. Definition of Timing for Fast/Standard Mode Devices on the I²C Bus

APPLICATIONS INFORMATION

not accept the request and issues a NACK by leaving the SDA line HIGH. If the conversion is complete, the LTC2471/LTC2473 issue an ACK by pulling the SDA line LOW.

Following the ACK, the LTC2471/LTC2473 can output data. The data output stream is 16 bits long and is shifted out on the falling edges of SCL (see Figure 6).

The DATA INPUT/OUTPUT state is concluded once all 16 data bits have been read or after a STOP condition.

The LTC2473 (differential input) output code is given by $INT(32767.5 \cdot (V_{IN}^+ - V_{IN}^-)/V_{REF} + 32767.5)$. The first bit output by the LTC2473, D15, is the MSB, which is 1 for $V_{IN}^+ \geq V_{IN}^-$ and 0 for $V_{IN}^+ < V_{IN}^-$. This bit is followed by successively less significant bits (D14, D13, ...) until the LSB is output by the LTC2473, see Table 1.

The LTC2471 (single-ended input) output code is a direct binary encoded result, see Table 1.

Table 1. LTC2471/LTC2473 Output Data Format

SINGLE ENDED INPUT V_{IN} (LTC2471)	DIFFERENTIAL INPUT VOLTAGE $V_{IN}^+ - V_{IN}^-$ (LTC2473)	D15 (MSB)	D14	D13	D12...D2	D1	D0 (LSB)	CORRESPONDING DECIMAL VALUE
$\geq V_{REF}$	$\geq V_{REF}$	1	1	1	1	1	1	65535
$V_{REF} - 1LSB$	$V_{REF} - 1LSB$	1	1	1	1	1	0	65534
$0.75 \cdot V_{REF}$	$0.5 \cdot V_{REF}$	1	1	0	0	0	0	49152
$0.75 \cdot V_{REF} - 1LSB$	$0.5 \cdot V_{REF} - 1LSB$	1	0	1	1	1	1	49151
$0.5 \cdot V_{REF}$	0	1	0	0	0	0	0	32768
$0.5 \cdot V_{REF} - 1LSB$	-1LSB	0	1	1	1	1	1	32767
$0.25 \cdot V_{REF}$	$-0.5 \cdot V_{REF}$	0	1	0	0	0	0	16384
$0.25 \cdot V_{REF} - 1LSB$	$-0.5 \cdot V_{REF} - 1LSB$	0	0	1	1	1	1	16383
0	$\leq -V_{REF}$	0	0	0	0	0	0	0

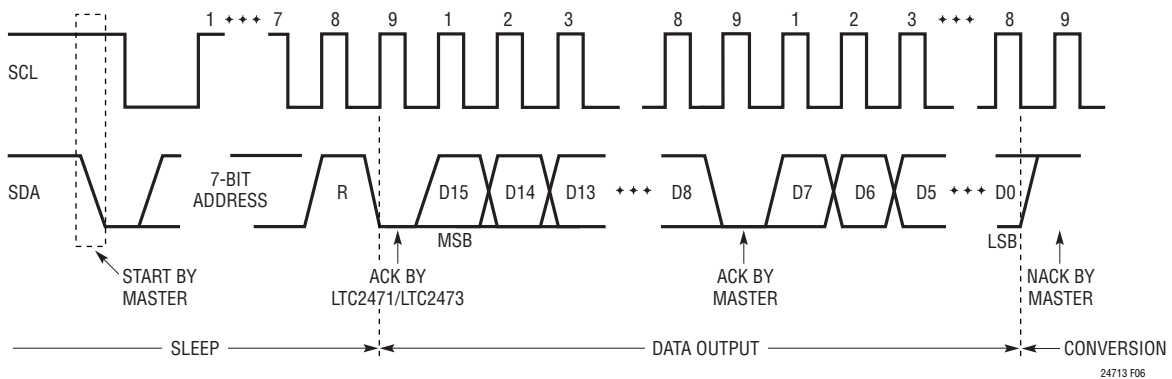

Figure 6. Read Sequence Timing Diagram

APPLICATIONS INFORMATION

Data Input Format

After a START condition, the master sends a 7-bit address followed by a read/write request (R/\bar{W}) bit. The R/\bar{W} bit is 0 for a write. The data input word is 4 bits long and consists of two enable bits (EN1 and EN2) and two programming bits (SPD and SLP), see Figure 7. EN1 is applied to the first rising edge of SCL after a valid write address is acknowledged. Programming is enabled by setting EN1 = 1 and EN2 = 0.

The speed bit (SPD) determines the output rate, SPD = 0 (default) for a 208sps and SPD = 1 for a 833sps output rate. The sleep bit (SLP) is used to power down the on-chip reference. In the default mode, the reference remains powered up at the conclusion of each conversion cycle while the ADC is automatically powered down at the end of each conversion cycle. If the SLP bit is set HIGH, the reference and the ADC are powered down once the next conversion cycle is completed. The reference and ADC are powered up again once a valid read/write is acknowledged. The following conversion is invalid if the next conversion is started before the reference has started up (see Figure 3 for reference startup times as a function of compensation capacitor and reference capacitor).

The sleep bit (SLP) is used to power down the on chip reference. In the default mode, the reference remains powered up even when the ADC is powered down. If the SLP bit is set HIGH, the reference will power down after the next conversion is complete. It will remain powered down until a valid address is acknowledged. The reference startup time is approximately 12ms. In order to ensure a stable reference for the following conversions, either the data input/output time should be delayed 12ms after an address acknowledge or the first conversion following a reference start up should be discarded.

Table 2. Input Data Format

BIT NAME	FUNCTION
EN1	Should Be High (EN1 = 1) in Order to Enable Program Mode
EN2	Should Be Low (EN2 = 0) in Order to Enable Program Mode
SPD	Low (SPD = 0, Default) for 208sps, High (SPD = 1) for 833sps Output Rate
SLP	Low (SLP = 0, Default) for Nap Mode, High (SLP = 1) for Sleep Mode Where Both Reference and Converter Are Powered Down

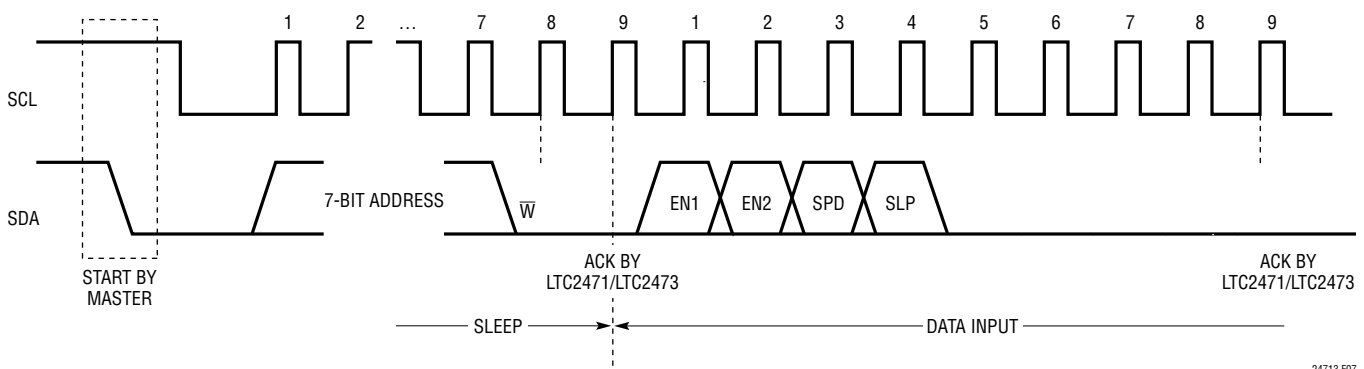

Figure 7. Timing Diagram for Writing to the LTC2471/LTC2473

24713 F07

APPLICATIONS INFORMATION

OPERATION SEQUENCE

Continuous Read

Conversions from the LTC2471/LTC2473 can be continuously read, see Figure 8. The R/\bar{W} is 1 for a read. At the end of a read operation, a new conversion automatically begins. At the conclusion of the conversion cycle, the next result may be read using the method described above. If the conversion cycle is not complete and a valid address selects the device, the LTC2471/LTC2473 generate a NACK

signal indicating the conversion cycle is in progress. See Figure 9 for an example state diagram.

Discarding a Conversion Result and Initiating a New Conversion

It is possible to start a new conversion without reading the old result, as shown in Figure 10. Following a valid 7-bit address, a read request (R/\bar{W}) bit, and a valid ACK, a STOP command will start a new conversion.

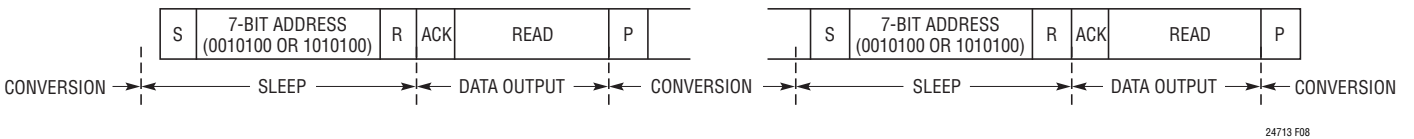

Figure 8. Consecutive Reading

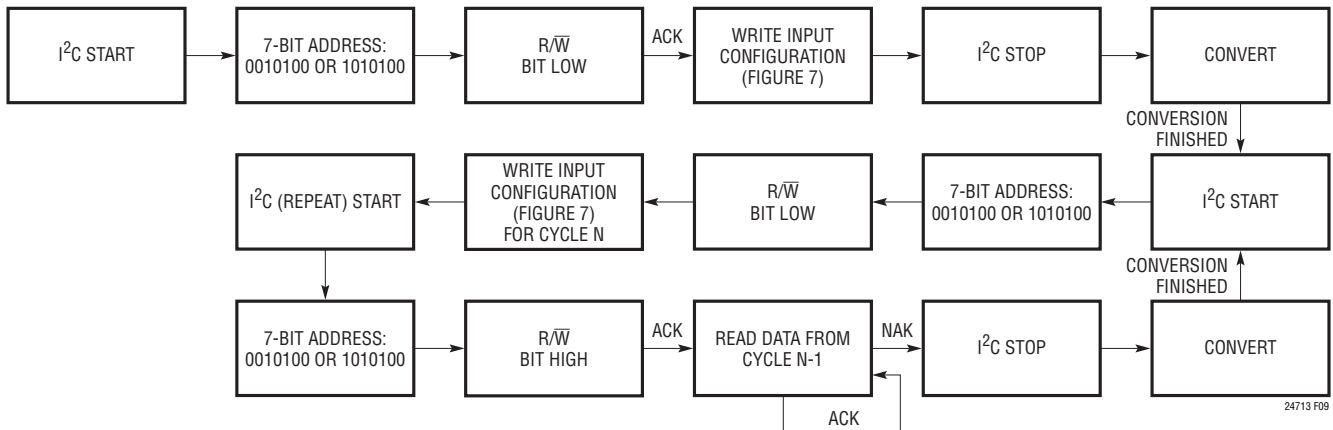

Figure 9. I²C State Diagram

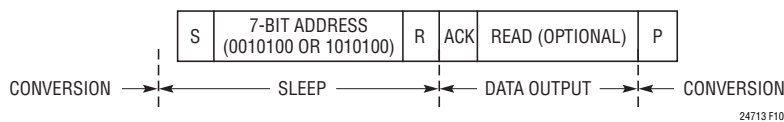

Figure 10. Start a New Conversion without Reading Old Conversion Result

APPLICATIONS INFORMATION

PRESERVING THE CONVERTER ACCURACY

The LTC2471/LTC2473 are designed to minimize the conversion result's sensitivity to device decoupling, PCB layout, anti-aliasing circuits, line and frequency perturbations. Nevertheless, in order to preserve the high accuracy capability of this part, some simple precautions are desirable.

Digital Signal Levels

Due to the nature of CMOS logic, it is advisable to keep input digital signals near GND or V_{CC} . Voltages in the range of 0.5V to $V_{CC} - 0.5V$ may result in additional current leakage from the part. Undershoot and overshoot should also be minimized, particularly while the chip is converting. It is thus beneficial to keep edge rates of about 10ns and limit overshoot and undershoot to less than 0.3V.

Driving V_{CC} and GND

In relation to the V_{CC} and GND pins, the LTC2471/LTC2473 combines internal high frequency decoupling with damping elements, which reduce the ADC performance sensitivity to PCB layout and external components. Nevertheless, the very high accuracy of this converter is best preserved by careful low and high frequency power supply decoupling.

A 0.1 μ F, high quality, ceramic capacitor in parallel with a 10 μ F low ESR ceramic capacitor should be connected between the V_{CC} and GND pins, as close as possible to the package. The 0.1 μ F capacitor should be placed closest to the ADC package. It is also desirable to avoid any via in the circuit path, starting from the converter V_{CC} pin, passing through these two decoupling capacitors, and returning to the converter GND pin. The area encompassed by this circuit path, as well as the path length, should be minimized.

As shown in Figure 11, REF⁻ is used as the negative reference voltage input to the ADC. This pin can be tied directly to ground or Kelvin sensed to sensor ground. In the case where REF⁻ is used as a sense input, it should be bypassed to ground with a 0.1 μ F ceramic capacitor in parallel with a 10 μ F low ESR ceramic capacitor.

Very low impedance ground and power planes, and star connections at both V_{CC} and GND pins, are preferable. The V_{CC} pin should have two distinct connections: the first to

the decoupling capacitors described above, and the second to the ground return for the power supply voltage source.

REFOUT and COMP

The on chip 1.25V reference is internally tied to the converter's reference input and is output to the REFOUT pin. A 0.1 μ F capacitor should be placed on the REFOUT pin. It is possible to reduce this capacitor, but the transition noise increases (see Figure 4). A 0.1 μ F capacitor should also be placed on the COMP pin. This pin is tied to an internal point in the reference and is used for stability. In order for the reference to remain stable, the capacitor placed on the COMP pin must be greater than or equal to the capacitor tied to the REFOUT pin. The REFOUT pin cannot be overridden by an external voltage.

Depending on the size of the capacitors tied to the REFOUT and COMP pins, the internal reference has a corresponding start up time. This start up time is typically 12ms when 0.1 μ F capacitors are used. The first conversion following power up can be discarded using the data abort com-

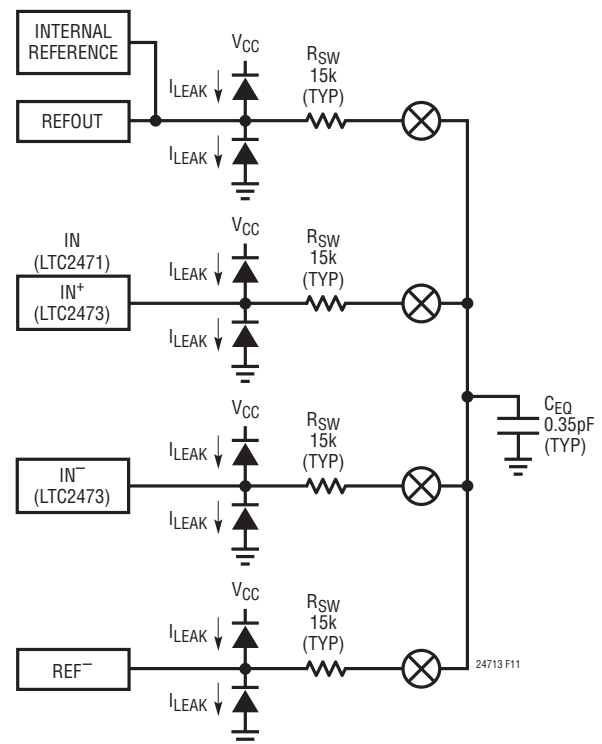

Figure 11. LTC2471/LTC2473 Analog Input/Reference Equivalent Circuit

APPLICATIONS INFORMATION

mand or simply read and ignored. Depending on the value chosen for C_{COMP} and C_{REFOUT} , the reference startup can take more than one conversion period, see Figure 3. If the startup time is less than 1.2ms (833sps output rate) or 4.8ms (208sps output rate) then conversions following the first period are accurate to the device specifications. If the startup time exceeds 1.2ms or 4.8ms then the user can wait the appropriate time or use the fixed conversion period as a startup timer by ignoring results within the unsettled period. Once the reference has settled all subsequent conversion results are valid. If the user places the device into the sleep mode ($SLP = 1$, reference powered down) the reference will require a startup time proportional to the value of C_{COMP} and C_{REFOUT} , see Figure 3.

If the reference is put to sleep (program $SLP = 1$ and $\overline{CS} = 1$) the reference is powered down after the next conversion. This last conversion result is valid. On \overline{CS} falling edge, the reference is powered back up. In order to ensure the reference output has settled before the next conversion, the power up time can be extended by delaying the data read after the falling edge of \overline{CS} . Once all 16 bits are read from the device or \overline{CS} is brought HIGH, the next conversion automatically begins. In the default operation, the reference remains powered up at the conclusion of the conversion cycle.

Driving V_{IN}^+ and V_{IN}^-

The input drive requirements can best be analyzed using the equivalent circuit of Figure 12. The input signal V_{SIG} is connected to the ADC input pins (IN^+ and IN^-) through an equivalent source resistance R_S . This resistor includes both the actual generator source resistance and any additional optional resistors connected to the input pins. Optional input capacitors C_{IN} are also connected to the ADC input pins. This capacitor is placed in parallel with the input parasitic capacitance C_{PAR} . This parasitic capacitance includes elements from the printed circuit board (PCB) and the associated input pin of the ADC. Depending on the PCB layout, C_{PAR} has typical values between 2pF and 15pF. In addition, the equivalent circuit of Figure 12 includes the

converter equivalent internal resistor R_{SW} and sampling capacitor C_{EQ} .

There are some immediate trade-offs in R_S and C_{IN} without needing a full circuit analysis. Increasing R_S and C_{IN} can give the following benefits:

- 1) Due to the LTC2471/LTC2473's input sampling algorithm, the input current drawn by either IN^+ or IN^- over a conversion cycle is typically 50nA. A high $R_S \cdot C_{IN}$ attenuates the high frequency components of the input current, and R_S values up to 1k result in <1LSB error.
- 2) The bandwidth from V_{SIG} is reduced at the input pins (IN^+ , IN^- or IN). This bandwidth reduction isolates the ADC from high frequency signals, and as such provides simple anti-aliasing and input noise reduction.
- 3) Switching transients generated by the ADC are attenuated before they go back to the signal source.
- 4) A large C_{IN} gives a better AC ground at the input pins, helping reduce reflections back to the signal source.
- 5) Increasing R_S protects the ADC by limiting the current during an outside-the-rails fault condition.

There is a limit to how large $R_S \cdot C_{IN}$ should be for a given application. Increasing R_S beyond a given point increases

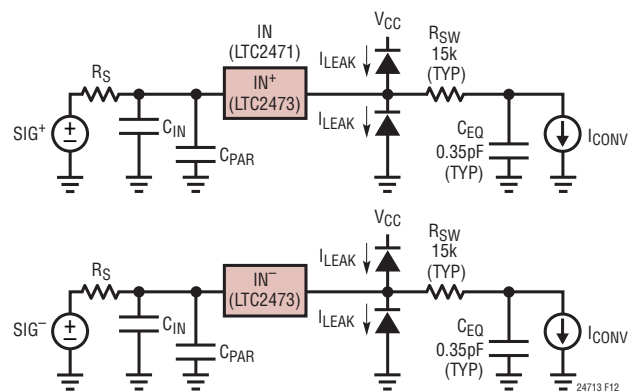

Figure 12. LTC2471/LTC2473 Input Drive Equivalent Circuit

APPLICATIONS INFORMATION

the voltage drop across R_S due to the input current, to the point that significant measurement errors exist. Additionally, for some applications, increasing the $R_S \cdot C_{IN}$ product too much may unacceptably attenuate the signal at frequencies of interest.

For most applications, it is desirable to implement C_{IN} as a high-quality 0.1 μ F ceramic capacitor and to set $R_S \leq 1k$. This capacitor should be located as close as possible to the actual IN^+ , IN^- and IN package pins. Furthermore, the area encompassed by this circuit path, as well as the path length, should be minimized.

In the case of a 2-wire sensor that is not remotely grounded, it is desirable to split R_S and place series resistors in the ADC input line as well as in the sensor ground return line, which should be tied to the ADC GND pin using a star connection topology.

Figure 13 shows the measured LTC2473 INL vs Input Voltage as a function of R_S value with an input capacitor $C_{IN} = 0.1\mu F$.

In some cases, R_S can be increased above these guidelines. The input current is zero when the ADC is either in sleep or I/O modes. Thus, if the time constant of the input RC circuit $\tau = R_S \cdot C_{IN}$, is of the same order of magnitude or longer than the time periods between actual conversions, then one can consider the input current to be reduced correspondingly.

These considerations need to be balanced out by the input signal bandwidth. The 3dB bandwidth $\approx 1/(2\pi R_S C_{IN})$.

Finally, if the recommended choice for C_{IN} is unacceptable for the user's specific application, an alternate strategy is to eliminate C_{IN} and minimize C_{PAR} and R_S . In practical terms, this configuration corresponds to a low impedance sensor directly connected to the ADC through minimum length traces. Actual applications include current measurements through low value sense resistors, temperature measure-

ments, low impedance voltage source monitoring, and so on. The resultant INL vs V_{IN} is shown in Figure 14. The measurements of Figure 14 include a capacitor C_{PAR} corresponding to a minimum sized layout pad and a minimum width input trace of about 1 inch length.

Signal Bandwidth, Transition Noise and Noise Equivalent Input Bandwidth

The LTC2471/LTC2473 include a sinc² type digital filter. The first notch is located at 416Hz if the 208sps output rate is selected and 1666Hz if the 833sps output rate is selected. The calculated input signal attenuation vs. frequency over a wide frequency range is shown in Figure 15. The calculated input signal attenuation vs. frequency at low frequencies is shown in Figure 16. The converter noise level is about $3\mu V_{RMS}$ and can be modeled by a white noise source connected at the input of a noise-free converter.

On a related note, the LTC2473 uses two separate A/D converters to digitize the positive and negative inputs. Each of these A/D converters has $3\mu V_{RMS}$ transition noise. If one of the input voltages is within this small transition noise band, then the output will fluctuate one bit, regardless of the value of the other input voltage. If both of the input voltages are within their transition noise bands, the output can fluctuate 2 bits.

For a simple system noise analysis, the V_{IN} drive circuit can be modeled as a single-pole equivalent circuit characterized by a pole location f_i and a noise spectral density n_i . If the converter has an unlimited bandwidth, or at least a bandwidth substantially larger than f_i , then the total noise contribution of the external drive circuit would be:

$$V_n = n_i \sqrt{\pi/2 \cdot f_i}$$

Then, the total system noise level can be estimated as the square root of the sum of (V_n^2) and the square of the LTC2471/LTC2473 noise floor.

APPLICATIONS INFORMATION

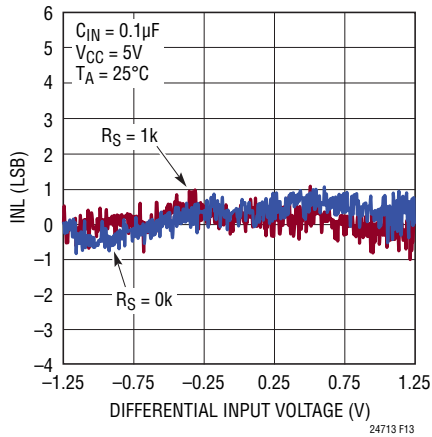

Figure 13. Measured INL vs Input Voltage

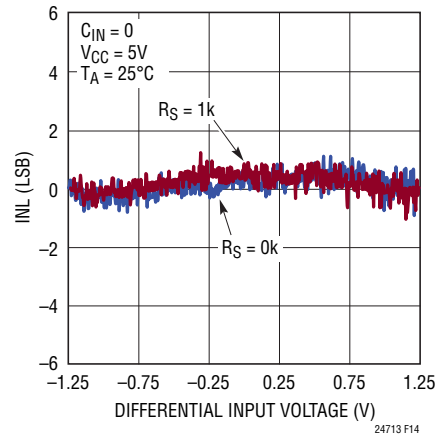

Figure 14. Measured INL vs Input Voltage

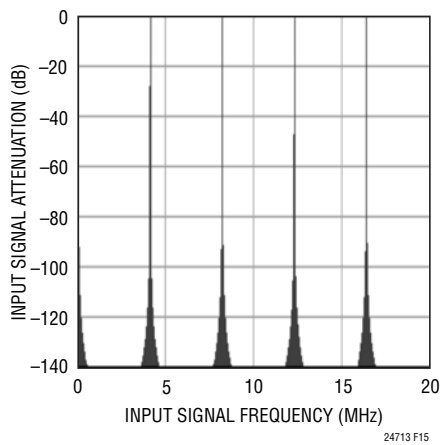

Figure 15. LTC2473 Input Signal Attenuation vs Frequency (208sps Mode)

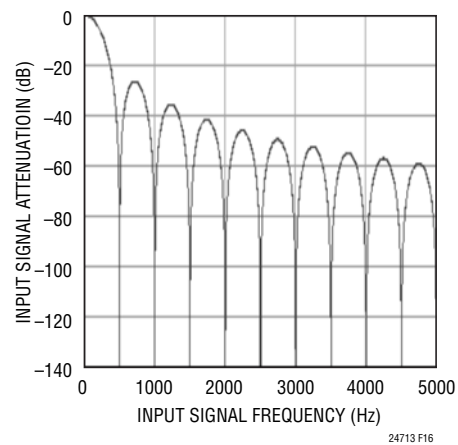

Figure 16. LTC2473 Input Signal Attenuation vs Frequency (208sps Mode)

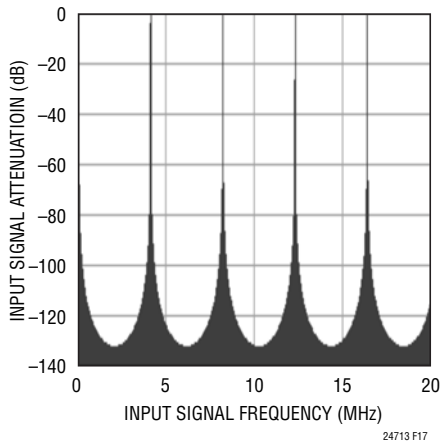

Figure 17. LTC2473 Input Signal Attenuation vs Frequency (833sps Mode)

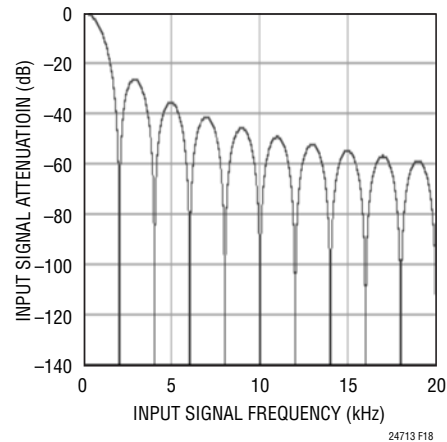

Figure 18. LTC2473 Input Signal Attenuation vs Frequency (833sps Mode)

PACKAGE DESCRIPTION

Please refer to <http://www.linear.com/designtools/packaging/> for the most recent package drawings.

MS Package 12-Lead Plastic MSOP

(Reference LTC DWG # 05-08-1668 Rev A)

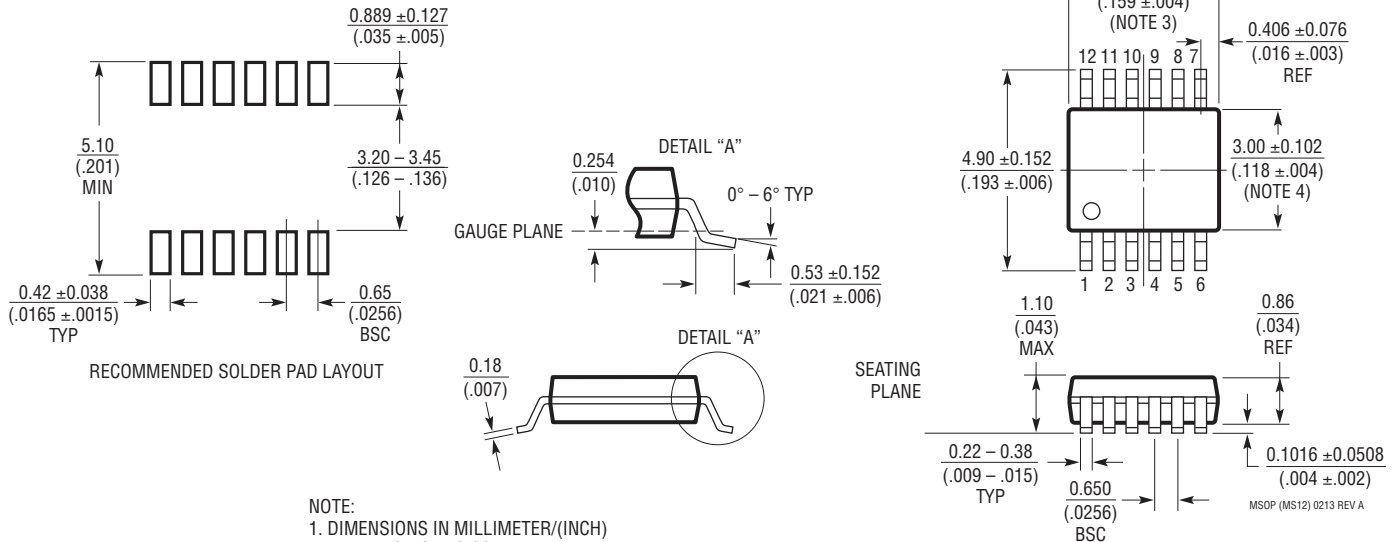

NOTE:

1. DIMENSIONS IN MILLIMETER/(INCH)
2. DRAWING NOT TO SCALE
3. DIMENSION DOES NOT INCLUDE MOLD FLASH, PROTRUSIONS OR GATE BURRS. MOLD FLASH, PROTRUSIONS OR GATE BURRS SHALL NOT EXCEED 0.152mm (.006") PER SIDE
4. DIMENSION DOES NOT INCLUDE INTERLEAD FLASH OR PROTRUSIONS. INTERLEAD FLASH OR PROTRUSIONS SHALL NOT EXCEED 0.152mm (.006") PER SIDE
5. LEAD COPLANARITY (BOTTOM OF LEADS AFTER FORMING) SHALL BE 0.102mm (.004") MAX

DD Package 12-Lead Plastic DFN (3mm x 3mm)

(Reference LTC DWG # 05-08-1725 Rev A)

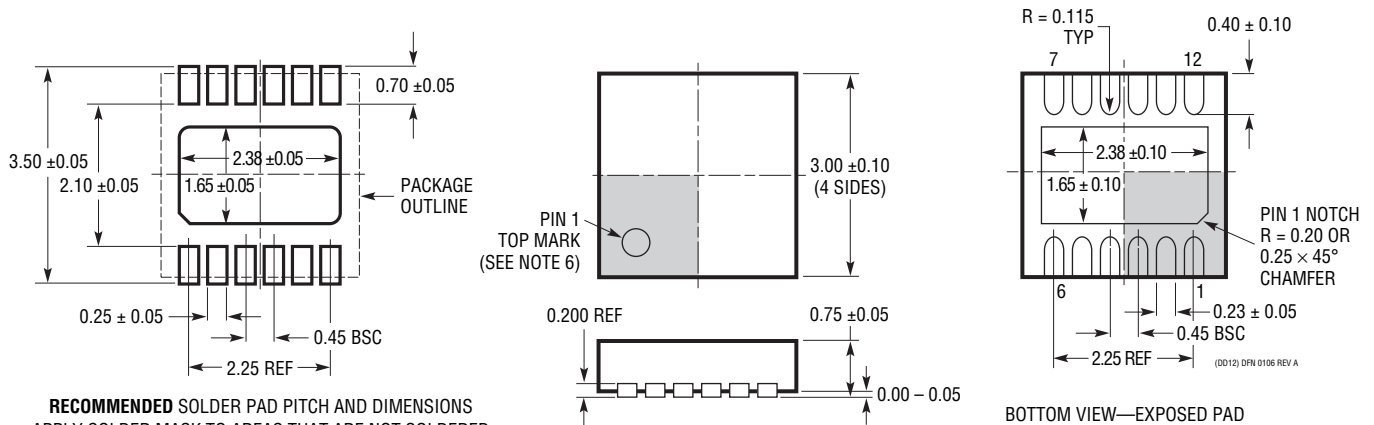

RECOMMENDED SOLDER PAD PITCH AND DIMENSIONS
APPLY SOLDER MASK TO AREAS THAT ARE NOT SOLDERED

NOTE:

1. DRAWING IS NOT A JEDEC PACKAGE OUTLINE
2. DRAWING NOT TO SCALE
3. ALL DIMENSIONS ARE IN MILLIMETERS
4. DIMENSIONS OF EXPOSED PAD ON BOTTOM OF PACKAGE DO NOT INCLUDE MOLD FLASH. MOLD FLASH, IF PRESENT, SHALL NOT EXCEED 0.15mm ON ANY SIDE
5. EXPOSED PAD AND TIE BARS SHALL BE SOLDER PLATED
6. SHADED AREA IS ONLY A REFERENCE FOR PIN 1 LOCATION ON THE TOP AND BOTTOM OF PACKAGE

REVISION HISTORY

REV	DATE	DESCRIPTION	PAGE NUMBER
A	09/13	Clarified maximum operating output rate as 208sps/833sps.	Global
B	03/14	Removed "No Missing Codes" resolution.	1, 3

LTC2471/LTC2473

TYPICAL APPLICATION

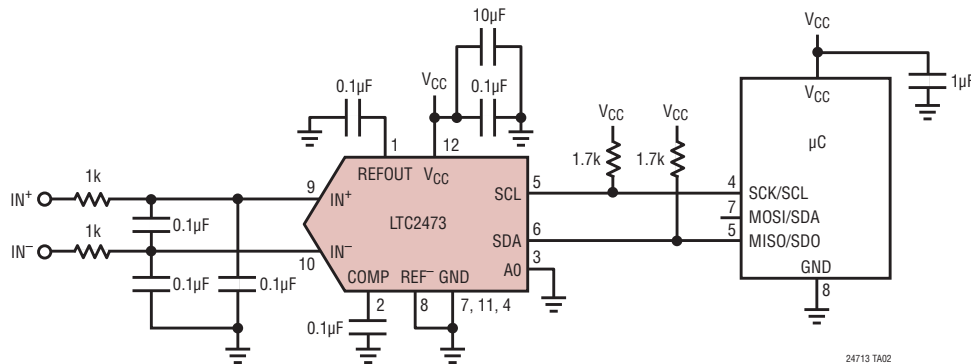

RELATED PARTS

PART NUMBER	DESCRIPTION	COMMENTS
LTC1860/LTC1861	12-Bit, 5V, 1-/2-Channel 250ksps SAR ADC in MSOP	850µA at 250ksps, 2µA at 1ksps, SO-8 and MSOP Packages
LTC1860L/LTC1861L	12-Bit, 3V, 1-/2-Channel 150ksps SAR ADC	450µA at 150ksps, 10µA at 1ksps, SO-8 and MSOP Packages
LTC1864/LTC1865	16-Bit, 5V, 1-/2-Channel 250ksps SAR ADC in MSOP	850µA at 250ksps, 2µA at 1ksps, SO-8 and MSOP Packages
LTC1864L/LTC1865L	16-bit, 3V, 1-/2-Channel 150ksps SAR ADC	450µA at 150ksps, 10µA at 1ksps, SO-8 and MSOP Packages
LTC2360	12-Bit, 100ksps SAR ADC	3V Supply, 1.5mW at 100ksps, TSOT 6-Pin/8-Pin Packages
LTC2440	24-Bit No Latency $\Delta\Sigma$ ADC	200nV _{RMS} Noise, 4kHz Output Rate, 15ppm INL
LTC2480	16-Bit, Differential Input, No Latency $\Delta\Sigma$ ADC, with PGA, Temp. Sensor, SPI	Easy Drive™ Input Current Cancellation, 600nV _{RMS} Noise, Tiny 10-Lead DFN Package
LTC2481	16-Bit, Differential Input, No Latency $\Delta\Sigma$ ADC, with PGA, Temp. Sensor, I ² C	Easy Drive Input Current Cancellation, 600nV _{RMS} Noise, Tiny 10-Lead DFN Package
LTC2482	16-Bit, Differential Input, No Latency $\Delta\Sigma$ ADC, SPI	Easy Drive Input Current Cancellation, 600nV _{RMS} Noise, Tiny 10-Lead DFN Package
LTC2483	16-Bit, Differential Input, No Latency $\Delta\Sigma$ ADC, I ² C	Easy Drive Input Current Cancellation, 600nV _{RMS} Noise, Tiny 10-Lead DFN Package
LTC2484	24-Bit, Differential Input, No Latency $\Delta\Sigma$ ADC, SPI with Temp. Sensor	Easy Drive Input Current Cancellation, 600nV _{RMS} Noise, Tiny 10-Lead DFN Package
LTC2485	24-Bit, Differential Input, No Latency $\Delta\Sigma$ ADC, I ² C with Temp. Sensor	Easy Drive Input Current Cancellation, 600nV _{RMS} Noise, Tiny 10-Lead DFN Package
LTC6241	Dual, 18MHz, Low Noise, Rail-to-Rail Op Amp	550nV _{p-p} Noise, 125µV Offset Max
LTC2450	Easy-to-Use, Ultra-Tiny 16-Bit ADC, SPI, 0V to 5.5V Input Range	2 LSB INL, 50nA Sleep Current, Tiny 2mm × 2mm DFN-6 Package, 30Hz Output Rate
LTC2450-1	Easy-to-Use, Ultra-Tiny 16-Bit ADC, SPI, 0V to 5.5V Input Range	2 LSB INL, 50nA Sleep Current, Tiny 2mm × 2mm DFN-6 Package, 60Hz Output Rate
LTC2451	Easy-to-Use, Ultra-Tiny 16-Bit ADC, I ² C, 0V to 5.5V Input Range	2 LSB INL, 50nA Sleep Current, Tiny 3mm × 2mm DFN-8 or TSOT Package, Programmable 30Hz/60Hz Output Rates
LTC2452	Easy-to-Use, Ultra-Tiny 16-Bit Differential ADC, SPI, ±5.5V Input Range	2 LSB INL, 50nA Sleep Current, Tiny 3mm × 2mm DFN-8 or TSOT Package
LTC2453	Easy-to-Use, Ultra-Tiny 16-Bit Differential ADC, I ² C, ±5.5V Input Range	2 LSB INL, 50nA Sleep Current, Tiny 3mm × 2mm DFN-8 or TSOT Package
LTC2460	Ultra-Tiny 16-Bit $\Delta\Sigma$ ADC with 10ppm Reference	Pin and Software Compatible with LTC2471, 60Hz Output Rate
LTC2462	Ultra-Tiny 16-Bit $\Delta\Sigma$ ADC with 10ppm Reference	Pin and Software Compatible with LTC2473, 60Hz Output Rate

24713fb

Looking for pricing, stock, or lifecycle information?

Click below to explore more details on WIN SOURCE:

 [View LTC2473CMS#PBF on WIN SOURCE](#)

 [Linear Technology](#) Information

Optimize Your Supply Chain with WIN SOURCE Solutions

-  Global Sourcing Solution
-  Obsolete Management
-  Cost Control Management
-  Shortage Management
-  Alternative Solution
-  Excess Inventory Management