



**THE DATASHEET OF
LTC2472CMS#PBF**



FEATURES

- 16-Bit Resolution
- Internal, High Accuracy Reference—10ppm/°C (Max)
- Single-Ended (LTC2470) or Differential (LTC2472)
- Selectable 208sps/833sps Output Rate
- 1mV Offset Error
- 0.01% Gain Error
- Single Conversion Settling Time for Multiplexed Applications
- Single-Cycle Operation with Auto Shutdown
- 3.5mA (Typ) Supply Current
- 2 μ A (Max) Sleep Current
- Internal Oscillator—No External Components Required
- SPI Interface
- Small 12-Lead, 3mm \times 3mm DFN and MSOP Packages

APPLICATIONS

- System Monitoring
- Environmental Monitoring
- Direct Temperature Measurements
- Instrumentation
- Industrial Process Control
- Data Acquisition
- Embedded ADC Upgrades

LT, LT, LTC, LTM, Linear Technology and the Linear logo are registered trademarks and No Latency $\Delta\Sigma$ is a trademark of Linear Technology Corporation. All other trademarks are the property of their respective owners. Protected by U.S. Patents, including 6208279, 6411242, 7088280, 7164378.

DESCRIPTION

The **LTC[®]2470/LTC2472** are small, 16-bit analog-to-digital converters with an integrated precision reference and a selectable 208sps or 833sps output rate. They use a single 2.7V to 5.5V supply and communicate through a SPI Interface. The LTC2470 is single-ended with a 0V to V_{REF} input range and the LTC2472 is differential with a $\pm V_{REF}$ input range. Both ADC's include a 1.25V integrated reference with 2ppm/°C drift performance and 0.1% initial accuracy. The converters are available in a 12-pin DFN 3mm \times 3mm package or an MSOP-12 package. They include an integrated oscillator and perform conversions with no latency for multiplexed applications. The LTC2470/LTC2472 include a proprietary input sampling scheme that reduces the average input current several orders of magnitude when compared to conventional delta sigma converters.

Following a single conversion, the LTC2470/LTC2472 automatically power down the converter and can also be configured to power down the reference. When both the ADC and reference are powered down, the supply current is reduced to 200nA.

The LTC2470/LTC2472 include a user selectable 208sps or 833sps output rate and due to a large oversampling ratio (8,192 at 208sps and 2,048 at 833sps) have relaxed anti-aliasing requirements.

TYPICAL APPLICATION

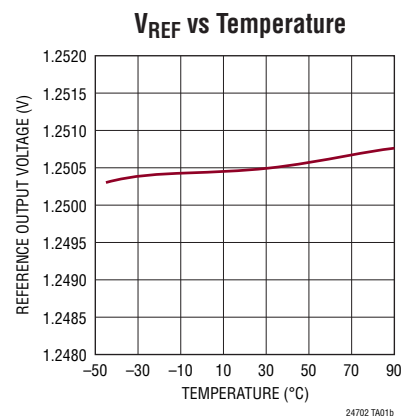
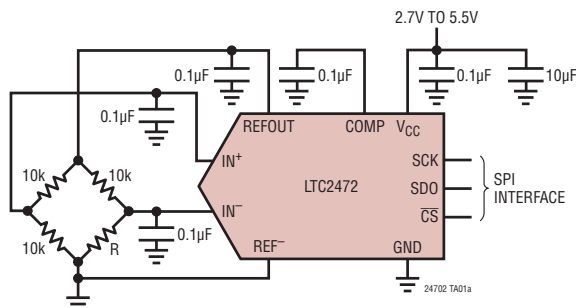

LTC2470/LTC2472

ABSOLUTE MAXIMUM RATINGS

(Notes 1, 2)

Supply Voltage (V_{CC}) $-0.3V$ to $6V$
 Analog Input Voltage
 (V_{IN}^+ , V_{IN}^- , V_{IN} , V_{REF}^- ,
 V_{COMP} , V_{REFOUT}) $-0.3V$ to $(V_{CC} + 0.3V)$
 Digital Voltage
 (V_{SDI} , V_{SDO} , V_{SCK} , V_{CS}) $-0.3V$ to $(V_{CC} + 0.3V)$

Storage Temperature Range $-65^{\circ}C$ to $150^{\circ}C$
 Operating Temperature Range
 LTC2470C/LTC2472C $0^{\circ}C$ to $70^{\circ}C$
 LTC2470I/LTC2472I $-40^{\circ}C$ to $85^{\circ}C$

PIN CONFIGURATION

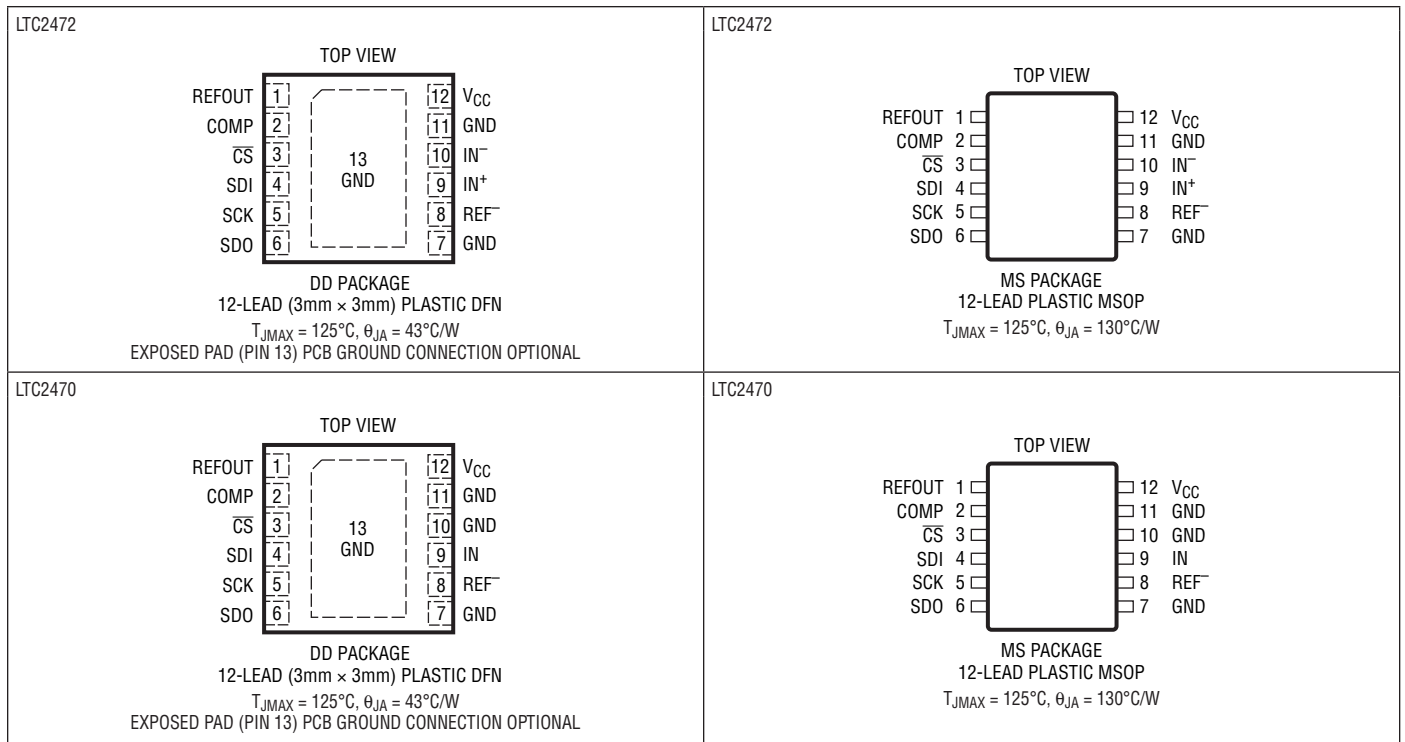

ORDER INFORMATION

LEAD FREE FINISH	TAPE AND REEL	PART MARKING*	PACKAGE DESCRIPTION	TEMPERATURE RANGE
LTC2470CDD#PBF	LTC2470CDD#TRPBF	LFPV	12-Lead Plastic (3mm × 3mm) DFN	$0^{\circ}C$ to $70^{\circ}C$
LTC2470IDD#PBF	LTC2470IDD#TRPBF	LFPV	12-Lead Plastic (3mm × 3mm) DFN	$-40^{\circ}C$ to $85^{\circ}C$
LTC2470CMS#PBF	LTC2470CMS#TRPBF	2470	12-Lead Plastic MSOP	$0^{\circ}C$ to $70^{\circ}C$
LTC2470IMS#PBF	LTC2470IMS#TRPBF	2470	12-Lead Plastic MSOP	$-40^{\circ}C$ to $85^{\circ}C$
LTC2472CDD#PBF	LTC2472CDD#TRPBF	LFGV	12-Lead Plastic (3mm × 3mm) DFN	$0^{\circ}C$ to $70^{\circ}C$
LTC2472IDD#PBF	LTC2472IDD#TRPBF	LFGV	12-Lead Plastic (3mm × 3mm) DFN	$-40^{\circ}C$ to $85^{\circ}C$

ORDER INFORMATION

LEAD FREE FINISH	TAPE AND REEL	PART MARKING*	PACKAGE DESCRIPTION	TEMPERATURE RANGE
LTC2472CMS#PBF	LTC2472CMS#TRPBF	2472	12-Lead Plastic MSOP	0°C to 70°C
LTC2472IMS#PBF	LTC2472IMS#TRPBF	2472	12-Lead Plastic MSOP	-40°C to 85°C

Consult LTC Marketing for parts specified with wider operating temperature ranges. *The temperature grade is identified by a label on the shipping container. Consult LTC Marketing for information on non-standard lead based finish parts.

For more information on lead free part marking, go to: <http://www.linear.com/leadfree/>

For more information on tape and reel specifications, go to: <http://www.linear.com/tapeandreel/>

ELECTRICAL CHARACTERISTICS

The ● denotes the specifications which apply over the full operating temperature range, otherwise specifications are at $T_A = 25^\circ\text{C}$. (Note 2)

PARAMETER	CONDITIONS	MIN	TYP	MAX	UNITS
Resolution			16		Bits
Integral Nonlinearity	Output Rate 208sps (Note 4)	●	2	8.5	LSB
	Output Rate 833sps (Note 4)	●	8	16	LSB
Offset Error		●	±1	±2.5	mV
Offset Error Drift			0.05		LSB/°C
Gain Error		●	±0.01	±0.25	% of FS
Gain Error Drift		●	0.15		LSB/°C
Transition Noise			3		μV_{RMS}
Power Supply Rejection DC			80		dB

ANALOG INPUTS

The ● denotes the specifications which apply over the full operating temperature range, otherwise specifications are at $T_A = 25^\circ\text{C}$.

SYMBOL	PARAMETER	CONDITIONS	MIN	TYP	MAX	UNITS	
V_{IN^+}	Positive Input Voltage Range	LTC2472	●	0	V_{REF}	V	
V_{IN^-}	Negative Input Voltage Range	LTC2472	●	0	V_{REF}	V	
V_{IN}	Input Voltage Range	LTC2470	●	0	V_{REF}	V	
$V_{\text{OR}^+}, V_{\text{UR}^+}$	Overrange/Underrange Voltage, IN^+	$V_{\text{IN}^-} = 0.625\text{V}$		8		LSB	
$V_{\text{OR}^-}, V_{\text{UR}^-}$	Overrange/Underrange Voltage, IN^-	$V_{\text{IN}^+} = 0.625\text{V}$		8		LSB	
C_{IN}	$\text{IN}^+, \text{IN}^-, \text{IN}$ Sampling Capacitance			0.35		pF	
$I_{\text{DC_LEAK}}(\text{IN}^+, \text{IN}^-, \text{IN})$	IN^+, IN^- DC Leakage Current (LTC2472) IN DC Leakage Current (LTC2470)	$V_{\text{IN}} = \text{GND}$ (Note 5)	●	-10	±1	10	nA
		$V_{\text{IN}} = V_{\text{CC}}$ (Note 5)	●	-10	±1	10	nA
I_{CONV}	Input Sampling Current (Note 8)			50		nA	
V_{REF}	Reference Output Voltage		●	1.247	1.25	1.253	V
	Reference Voltage Coefficient	(Note 9) C-Grade I-Grade	●		±2 ±5	±10	ppm/°C ppm/°C
	Reference Line Regulation	$2.7\text{V} \leq V_{\text{CC}} \leq 5.5\text{V}$			-90		dB
	Reference Short Circuit Current	$V_{\text{CC}} = 5.5$, Forcing Output to GND	●			35	mA
	COMP Pin Short Circuit Current	$V_{\text{CC}} = 5.5$, Forcing Output to GND	●			200	μA
	Reference Load Regulation	$2.7\text{V} \leq V_{\text{CC}} \leq 5.5\text{V}$, $I_{\text{OUT}} = 100\mu\text{A}$ Sourcing			3.5		mV/mA
	Reference Output Noise Density	$C_{\text{COMP}} = 0.1\mu\text{F}$, $C_{\text{REFOUT}} = 0.1\mu\text{F}$, At $f = 1\text{ksps}$			30		$\text{nV}/\sqrt{\text{Hz}}$

LTC2470/LTC2472

POWER REQUIREMENTS

The ● denotes the specifications which apply over the full operating temperature range, otherwise specifications are at $T_A = 25^\circ\text{C}$.

SYMBOL	PARAMETER	CONDITIONS	MIN	TYP	MAX	UNITS
V_{CC}	Supply Voltage		● 2.7		5.5	V
I_{CC}	Supply Current					
	Conversion	$\overline{CS} = \text{GND}$ (Note 6) LTC2472	●	3.5	5	mA
	Conversion	$\overline{CS} = \text{GND}$ (Note 6) LTC2470	●	2.5	4	mA
	Nap	$\overline{CS} = V_{CC}$ (Note 6)	●	800	1500	μA
	Sleep	$\overline{CS} = V_{CC}$ (Note 6)	●	0.2	2	μA

DIGITAL INPUTS AND DIGITAL OUTPUTS

The ● denotes the specifications which apply over the full operating temperature range, otherwise specifications are at $T_A = 25^\circ\text{C}$. (Note 2)

SYMBOL	PARAMETER	CONDITIONS	MIN	TYP	MAX	UNITS
V_{IH}	High Level Input Voltage		● $V_{CC} - 0.3$			V
V_{IL}	Low Level Input Voltage				● 0.3	V
I_{IN}	Digital Input Current		● -10		10	μA
C_{IN}	Digital Input Capacitance			10		pF
V_{OH}	High Level Output Voltage	$I_O = -800\mu\text{A}$	● $V_{CC} - 0.5$			V
V_{OL}	Low Level Output Voltage	$I_O = 1.6\text{mA}$			● 0.4	V
I_{OZ}	Hi-Z Output Leakage Current		● -10		10	μA

TIMING CHARACTERISTICS

The ● denotes the specifications which apply over the full operating temperature range, otherwise specifications are at $T_A = 25^\circ\text{C}$.

SYMBOL	PARAMETER	CONDITIONS	MIN	TYP	MAX	UNITS
t_{CONV1}	Conversion Time	SPD = 0	● 3.2	4	4.8	ms
t_{CONV2}	Conversion Time	SPD = 1	● 0.8	1	1.2	ms
f_{SCK}	SCK Frequency Range				● 2	MHz
t_{LSCK}	SCK Low Period	(Note 7)	● 250			ns
t_{HSCK}	SCK High Period	(Note 7)	● 250			ns
t_1	\overline{CS} Falling Edge to SDO Low Z	(Note 7)	● 0		100	ns
t_2	\overline{CS} Rising Edge to SDO High Z	(Note 7)	● 0		100	ns
t_3	\overline{CS} Falling Edge to SCK Falling Edge	(Note 7)	● 100			ns
t_4	SDI Setup Before SCK \uparrow	(Notes 3, 7)	● 100			ns
t_5	SDI Hold After SCK \uparrow	(Notes 3, 7)	● 100			ns
t_{KQ}	SCK Falling Edge to SDO Valid	(Note 7)	● 0		100	ns

Note 1: Stresses beyond those listed under Absolute Maximum Ratings may cause permanent damage to the device. Exposure to any Absolute Maximum Rating condition for extended periods may affect device reliability and lifetime.

Note 2: All voltage values are with respect to GND. $V_{CC} = 2.7\text{V}$ to 5.5V unless otherwise specified.

$$V_{REFCM} = V_{REF}/2, FS = V_{REF}, -V_{REF} \leq V_{IN} \leq V_{REF}$$

$$V_{IN} = V_{IN^+} - V_{IN^-}, V_{INCM} = (V_{IN^+} + V_{IN^-})/2. \text{ (LTC2472)}$$

Note 3: Guaranteed by design, not subject to test.

Note 4: Integral nonlinearity is defined as the deviation of a code from a straight line passing through the actual endpoints of the transfer curve.

Note 5: $\overline{CS} = V_{CC}$. A positive current is flowing into the DUT pin.

Note 6: $SCK = V_{CC}$ or GND. SDO is high impedance.

Note 7: See Figure 5.

Note 8: Input sampling current is the average input current drawn from the input sampling network while the LTC2470/LTC2472 is actively sampling the input.

Note 9: Temperature coefficient is calculated by dividing the maximum change in output voltage by the specified temperature range.

TYPICAL PERFORMANCE CHARACTERISTICS ($T_A = 25^\circ\text{C}$, unless otherwise noted)

Integral Nonlinearity

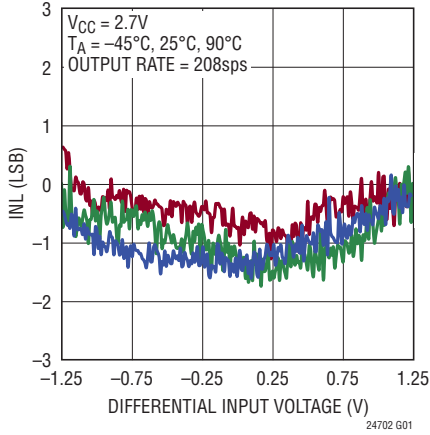

Integral Nonlinearity

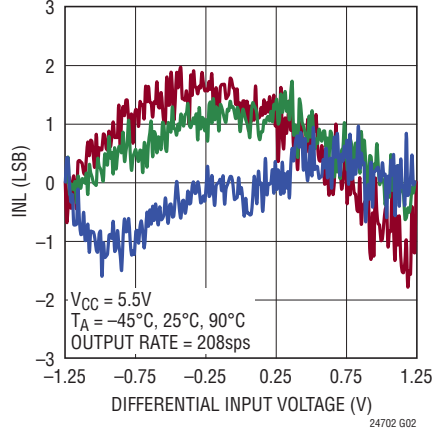

Maximum INL vs Temperature

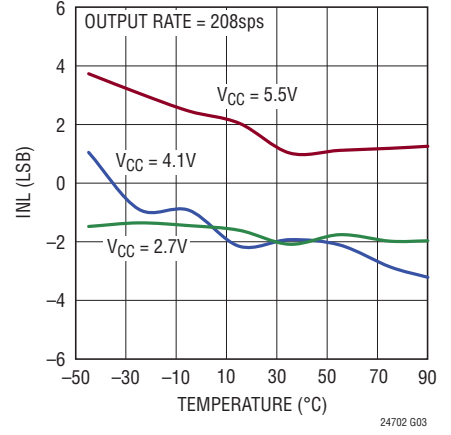

Offset Error vs Temperature

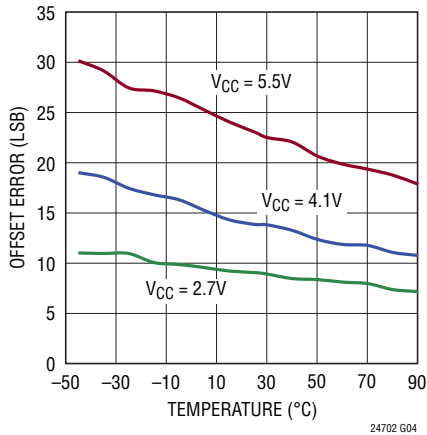

ADC Gain Error vs Temperature

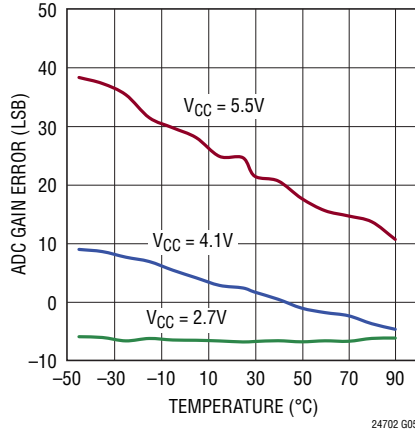

Transition Noise vs Temperature

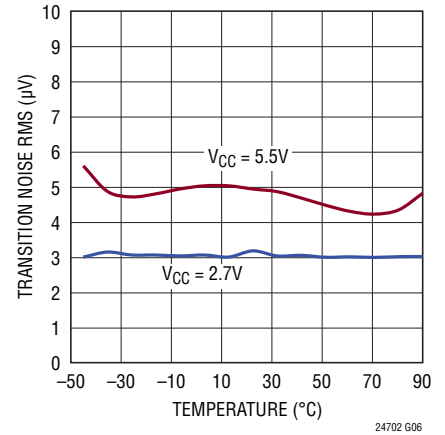

Conversion Mode Power Supply Current vs Temperature

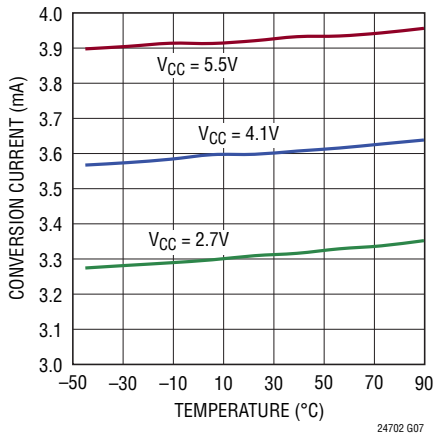

Sleep Mode Power Supply Current vs Temperature

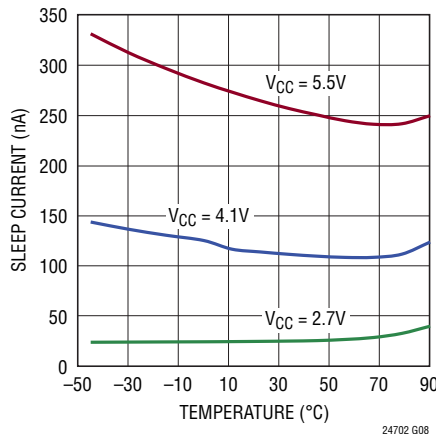

VREF vs Temperature

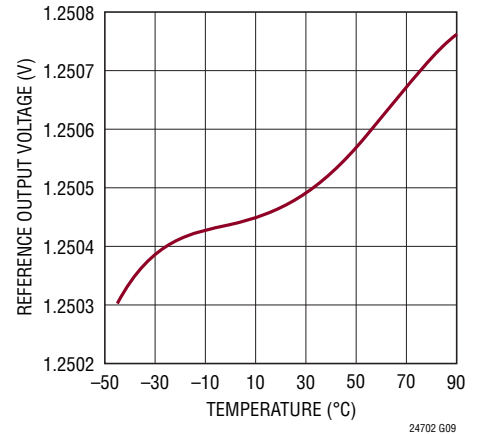

TYPICAL PERFORMANCE CHARACTERISTICS ($T_A = 25^\circ\text{C}$, unless otherwise noted)

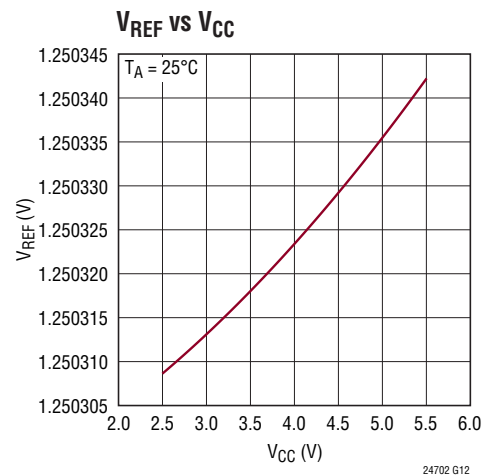
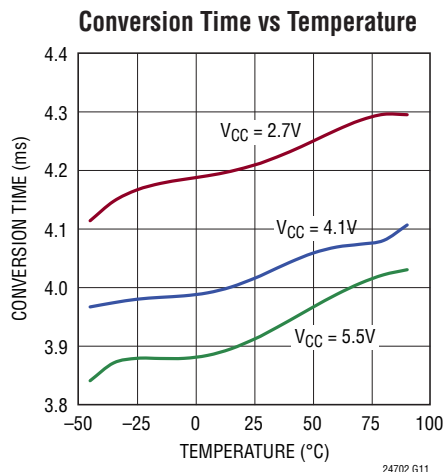
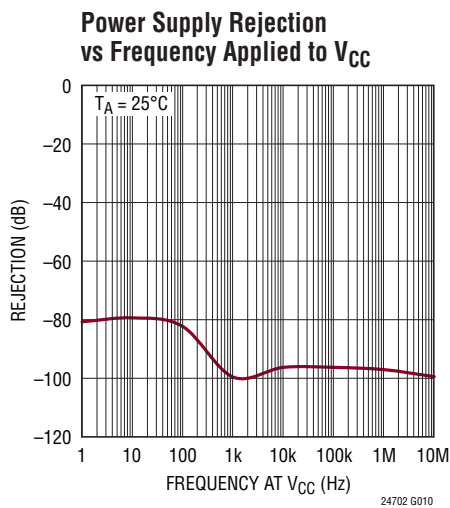

PIN FUNCTIONS

REFOUT (Pin 1): Reference Output Pin. Nominally 1.25V, this voltage sets the full-scale input range of the ADC. For noise and reference stability connect to a $0.1\mu\text{F}$ capacitor tied to GND. This capacitor value must be less than or equal to the capacitor tied to the reference compensation pin (COMP). REFOUT cannot be overdriven by an external reference.

COMP (Pin 2): Internal Reference Compensation Pin. For low noise and reference stability, tie a $0.1\mu\text{F}$ capacitor to GND.

$\overline{\text{CS}}$ (Pin 3): Chip Select (Active LOW) Digital Input. A LOW on this pin enables the SDO output. A HIGH on this pin places the SDO output pin in a high impedance state and any inputs on SDI and SCK will be ignored.

SDI (Pin 4): Serial Data Input Pin. This pin is used to program the sleep mode and the 208sps/833sps output rate.

SCK (Pin 5): Serial Clock Input. SCK synchronizes the serial data input/output. Once the conversion is complete, a new data bit is produced at the SDO pin following each SCK falling edge. Data is shifted into the SDI pin on each rising edge of SCK.

SDO (Pin 6): Three-State Serial Data Output. SDO is used for serial data output during the DATA INPUT/OUTPUT state. This pin goes Hi-Z when $\overline{\text{CS}}$ is high.

GND (Pins 7, 11, Exposed Pad Pin 13 – DFN Package): Ground. Connect directly to the ground plane through a low impedance connection.

REF⁻ (Pin 8): Negative Reference Input to the ADC. The voltage on this pin sets the zero input to the ADC. This pin should be tied directly to ground or the ground sense of the input sensor.

IN⁺ (LTC2472), IN (LTC2470) (Pin 9): Positive input voltage for the LTC2472 differential device. ADC input for the LTC2470 single-ended device.

IN⁻ (LTC2472), GND (LTC2470) (Pin 10): Negative input voltage for the LTC2472 differential device. GND for the LTC2470 single-ended device.

V_{CC} (Pin 12): Positive Supply Voltage. Bypass to GND with a $10\mu\text{F}$ capacitor in parallel with a low-series-inductance $0.1\mu\text{F}$ capacitor located as close to the device as possible.

BLOCK DIAGRAM

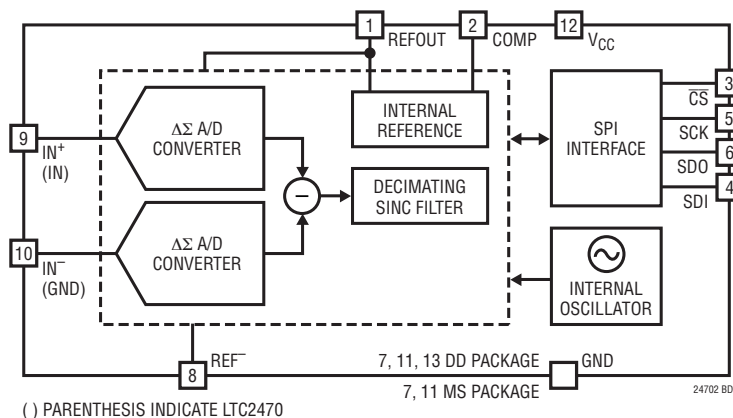

Figure 1. Functional Block Diagram

APPLICATIONS INFORMATION

CONVERTER OPERATION

Converter Operation Cycle

The LTC2470/LTC2472 are low power, delta sigma, analog to digital converters with a simple SPI interface and a user selected 208sps/833sps output rate (see Figure 1). The LTC2472 has a fully differential input while the LTC2470 is single-ended. Both are pin and software compatible. Their operation is composed of three distinct states: CONVERT, SLEEP/NAP, and DATA INPUT/OUTPUT. The operation begins with the CONVERT state (see Figure 2). Once the conversion is finished, the converter automatically powers down (NAP) or under user control, both the converter and reference are powered down (SLEEP). The conversion result is held in a static register while the device is in this state. The cycle concludes with the DATA INPUT/OUTPUT state. Once all 16-bits are read or an abort is initiated the device begins a new conversion.

The CONVERT state duration is determined by the LTC2470/LTC2472 conversion time (nominally 4ms or 1ms depending on the selected output rate). Once started, this operation can not be aborted except by a low power supply condition ($V_{CC} < 2.1V$) which generates an internal power-on reset signal.

After the completion of a conversion, the LTC2470/LTC2472 enters the SLEEP/NAP state and remains there until the chip select is LOW ($\overline{CS} = LOW$). Following this condition, the ADC transitions into the DATA INPUT/OUTPUT state.

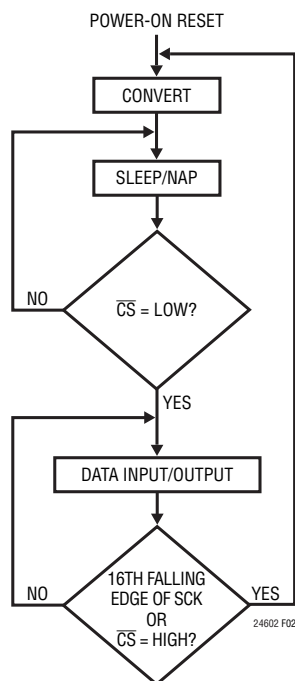

Figure 2. LTC2470/LTC2472 State Transition Diagram

While in the SLEEP/NAP state, when chip select input is HIGH ($\overline{CS} = HIGH$), the LTC2470/LTC2472's converters are powered down. This reduces the supply current by approximately 70%. While in the NAP state the reference remains powered up. The user can power down both the reference and the converter by enabling the sleep mode during the DATA INPUT/OUTPUT state. Once the next conversion is

APPLICATIONS INFORMATION

complete, the SLEEP state is entered and power is reduced to $2\mu\text{A}$ (maximum). The reference is powered up once $\overline{\text{CS}}$ is brought low. The reference startup time is 12ms (if the reference and compensation capacitor values are both $0.1\mu\text{F}$). As the reference and compensation capacitors are decreased, the startup time is reduced (see Figure 3), but the transition noise increases (see Figure 4).

Upon entering the DATA INPUT/OUTPUT state, SDO outputs the sign (D15) of the conversion result. During this state, the ADC shifts the conversion result serially through the SDO output pin under the control of the SCK input pin. There is no latency in generating this data and the result corresponds to the last completed conversion. A new bit of data appears at the SDO pin following each falling edge detected at the SCK input pin and appears

from MSB to LSB. The user can reliably latch this data on every rising edge of the external serial clock signal driving the SCK pin.

During the DATA INPUT/OUTPUT state, the LTC2470/LTC2472 can be programmed to SLEEP or NAP (default) and the output rate can be updated. Data is shifted into the device through the SDI pin on the rising edge of SCK. The input word is 4 bits. If the first bit $\text{EN1} = 1$ and the second bit $\text{EN2} = 0$ the device is enabled for programming. The following two bits (SPD and SLP) will be written into the device. SPD is used to select the output rate. If $\text{SPD} = 0$ (Default) the output rate is 208sps and $\text{SPD} = 1$ sets a 833sps output rate. The next bit (SLP) enables the sleep or nap mode. If $\text{SLP} = 0$ (default) the reference remains powered up at the end of each conversion cycle. If $\text{SLP} = 1$, the reference powers down following the next conversion cycle. The remaining 12 SDI input bits are ignored (don't care).

SDI may also be tied directly to GND or V_{DD} in order to simplify the user interface. If SDI is tied LOW the output rate is 208sps and if SDI is tied HIGH the output rate is 833sps. The reference sleep mode is disabled if SDI is tied to GND or V_{DD} .

The DATA INPUT/OUTPUT state concludes in one of two different ways. First, the DATA INPUT/OUTPUT state operation is completed once all 16 data bits have been shifted out and the clock then goes low. This corresponds to the 16th falling edge of SCK. Second, the DATA INPUT/OUTPUT state can be aborted at any time by a LOW-to-HIGH transition on the $\overline{\text{CS}}$ input. Following either one of these two actions, the LTC2470/LTC2472 will enter the CONVERT state and initiate a new conversion cycle.

Power-Up Sequence

When the power supply voltage (V_{CC}) applied to the converter is below approximately 2.1V, the ADC performs a power-on reset. This feature guarantees the integrity of the conversion result.

When V_{CC} rises above this critical threshold, the converter generates an internal power-on reset (POR) signal for approximately 0.5ms. For proper operation V_{DD} needs to be restored to normal operating range (2.7V to 5.5V)

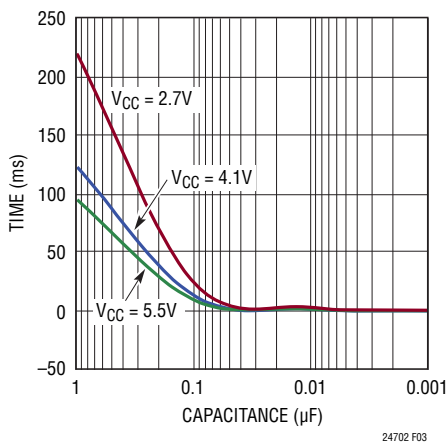

Figure 3. Reference Start-Up Time vs V_{REF} and Compensation Capacitance

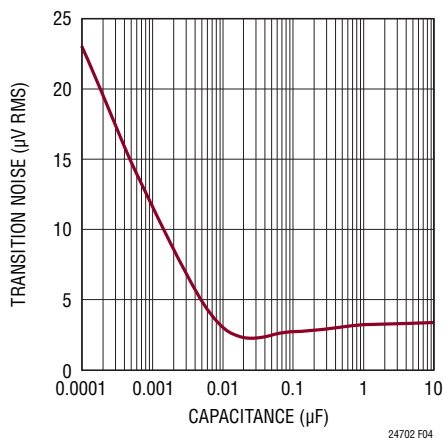

Figure 4. Transition Noise RMS vs COMP and Reference Capacitance

APPLICATIONS INFORMATION

before the conclusion of the POR cycle. The POR signal clears all internal registers. Following the POR signal, the LTC2470/LTC2472 start a conversion cycle and follow the succession of states shown in Figure 2. The reference startup time following a POR is 12ms ($C_{COMP} = C_{REFOUT} = 0.1\mu\text{F}$). The first conversion following power-up will be invalid since the reference voltage has not completely settled. The first conversion following power up can be discarded using the data abort command or simply read and ignored. Depending on the value chosen for C_{COMP} and C_{REFOUT} , the reference startup can take more than one conversion period, see Figure 3. If the startup time is less than 1.2ms (833sps output rate) or 4.8ms (208sps output rate) then conversions following the first period are accurate to the device specifications. If the startup time exceeds 1.2ms or 4.8ms then the user can wait the appropriate time or use the fixed conversion period as a startup timer by ignoring results within the unsettled period. Once the reference has settled, all subsequent conversion results are valid. If the user places the device into the sleep mode ($SLP = 1$, reference powered down) the reference will require a startup time proportional to the value of C_{COMP} and C_{REFOUT} (see Figure 3).

Ease of Use

The LTC2470/LTC2472 data output has no latency, filter settling delay, or redundant results associated with the conversion cycle. There is a one-to-one correspondence between the conversion and the output data. Therefore, multiplexing multiple analog input voltages requires no special actions.

The LTC2470/LTC2472 include a proprietary input sampling scheme that reduces the average input current by several orders of magnitude when compared to traditional delta-sigma architectures. This allows external filter networks to interface directly to the LTC2470/LTC2472. Since the average input sampling current is 50nA, an external RC lowpass filter using 1k Ω and 0.1 μF results in <1LSB additional error. Additionally, there is negligible leakage current between IN^+ and IN^- (for the LTC2472).

Input Voltage Range (LTC2470)

Ignoring offset and full-scale errors, the LTC2470 will theoretically output an “all zero” digital result when the input is at ground (a zero scale input) and an “all one” digital result when the input is at V_{REF} or higher ($V_{REFOUT} = 1.25\text{V}$). In an underrange condition (for all input voltages below zero scale) the converter will generate the output code 0. In an overrange condition (for all input voltages greater than V_{REF}) the converter will generate the output code 65535.

Input Voltage Range (LTC2472)

As detailed in the Output Data Format section, the output code is given as $32768 \cdot (V_{IN^+} - V_{IN^-})/V_{REF} + 32768$. For $(V_{IN^+} - V_{IN^-}) \geq V_{REF}$, the output code is clamped at 65535 (all ones). For $(V_{IN^+} - V_{IN^-}) \leq -V_{REF}$ the output code is clamped at 0 (all zeroes).

Output Data Format

The LTC2470/LTC2472 generates a 16-bit direct binary encoded result. It is provided as a 16-bit serial stream through the SDO output pin under the control of the SCK input pin (see Figure 5).

The LTC2472 (differential input) output code is given by $32768 \cdot (V_{IN^+} - V_{IN^-})/V_{REF} + 32768$. The first bit output by the LTC2472, D15, is the MSB, which is 1 for $V_{IN^+} \geq V_{IN^-}$ and 0 for $V_{IN^+} < V_{IN^-}$. This bit is followed by successively less significant bits (D14, D13, ...) until the LSB is output by the LTC2472, see Table 1.

The LTC2470 (single-ended input) output code is a direct binary encoded result, see Table 1.

During the data output operation the \overline{CS} input pin must be pulled low ($\overline{CS} = \text{LOW}$). The data output process starts with the most significant bit of the result being present at the SDO output pin ($SDO = D15$) once \overline{CS} goes low. A new data bit appears at the SDO output pin after each falling edge detected at the SCK input pin. The output data can be reliably latched on the rising edge of SCK.

APPLICATIONS INFORMATION

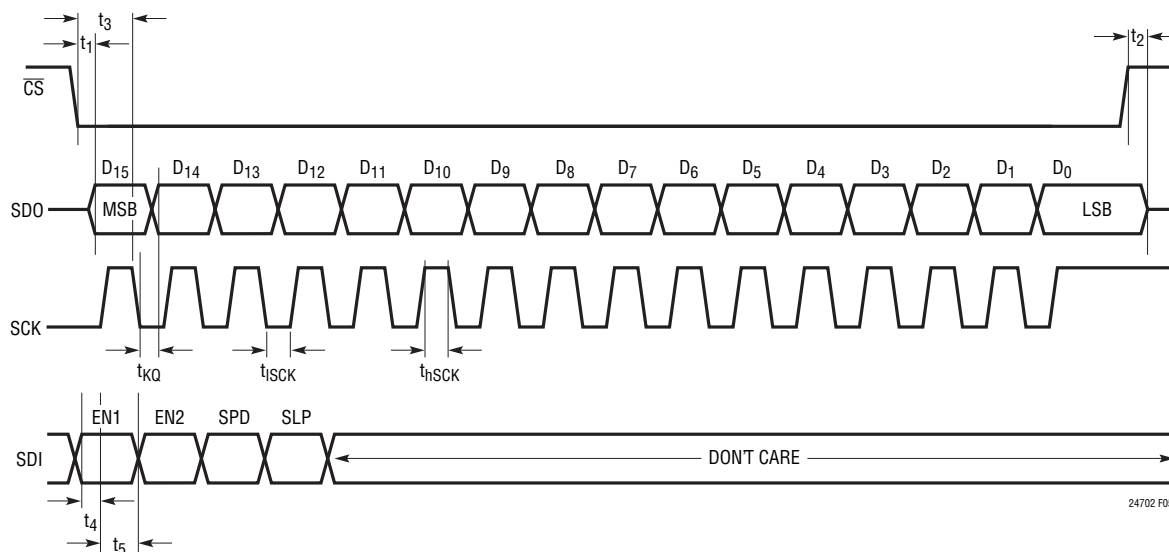

Figure 5. Data Input/Output Timing

Table 1. LTC2470/LTC2472 Output Data Format

SINGLE ENDED INPUT V_{IN} (LTC2470)	DIFFERENTIAL INPUT VOLTAGE $V_{IN}^+ - V_{IN}^-$ (LTC2472)	D15 (MSB)	D14	D13	D12...D2	D1	D0 (LSB)	CORRESPONDING DECIMAL VALUE
$\geq V_{REF}$	$\geq V_{REF}$	1	1	1	1	1	1	65535
$V_{REF} - 1\text{LSB}$	$V_{REF} - 1\text{LSB}$	1	1	1	1	1	0	65534
$0.75 \cdot V_{REF}$	$0.5 \cdot V_{REF}$	1	1	0	0	0	0	49152
$0.75 \cdot V_{REF} - 1\text{LSB}$	$0.5 \cdot V_{REF} - 1\text{LSB}$	1	0	1	1	1	1	49151
$0.5 \cdot V_{REF}$	0	1	0	0	0	0	0	32768
$0.5 \cdot V_{REF} - 1\text{LSB}$	-1LSB	0	1	1	1	1	1	32767
$0.25 \cdot V_{REF}$	$-0.5 \cdot V_{REF}$	0	1	0	0	0	0	16384
$0.25 \cdot V_{REF} - 1\text{LSB}$	$-0.5 \cdot V_{REF} - 1\text{LSB}$	0	0	1	1	1	1	16383
0	$\leq -V_{REF}$	0	0	0	0	0	0	0

Data Input Format

The data input word is 4 bits long and consists of two enable bits (EN1 and EN2) and two programming bits (SPD and SLP) see Table 2. EN1 is applied to the first rising edge of SCK after the conversion is complete. Programming is enabled by setting EN1 = 1 and EN2 = 0.

Table 2. Input Data Format

BIT NAME	FUNCTION
EN1	Should Be High (EN1 = 1) in Order to Enable Program Mode
EN2	Should Be Low (EN2 = 0) in Order to Enable Program Mode
SPD	Low (SPD = 0, Default) for 208sps, High (SPD = 1) for 833sps Output Rate
SLP	Low (SLP = 0, Default) for Nap Mode, High (SLP = 1) for Sleep Mode Where Both Reference and Converter are Powered Down

*SDI May Also Be Tied Directly to GND to Set Output Rate to 208sps or V_{DD} to Set Output Rate to 833sps. Sleep Mode is Disabled if SDI is Tied to GND or V_{DD} .

APPLICATIONS INFORMATION

The speed bit (SPD) determines the output rate, SPD = 0 (default) for a 208sps and SPD = 1 for a 833sps output rate. The sleep bit (SLP) is used to power down the on-chip reference. In the default mode, the reference remains powered up at the conclusion of each conversion cycle while the ADC is automatically powered down at the end of each conversion cycle. If the SLP bit is set HIGH, the reference and the ADC are powered down once the next conversion cycle is completed. The reference and ADC are powered up again once \overline{CS} is pulled low. The following conversion is invalid if the next conversion is started before the reference has started up (see Figure 3 for reference startup times as a function of compensation capacitor and reference capacitor).

If the sleep mode is not required, SPD can be tied to GND or V_{DD} in order to simplify the user interface. It should be noted that by tying SDI to GND, the output rate will be set to 208sps. Tying SDI to V_{DD} will result in a 833sps output rate.

SERIAL INTERFACE

The LTC2470/LTC2472 transmit the conversion result and receive the start of conversion command through a synchronous 2-, 3- or 4-wire interface. This interface can be used during the DATA OUTPUT state to read the conversion result, program sleep and speed mode, and to trigger a new conversion.

Serial Interface Operation Modes

The modes of operation can be summarized as follows:

- 1) The LTC2470/LTC2472 function with SCK idle high (commonly known as CPOL = 1) or idle low (commonly known as CPOL = 0).
- 2) After the 16th bit is read, a new conversion is started if \overline{CS} is pulled high or SCK is pulled low.
- 3) At any time during the Data Output state, pulling \overline{CS} high causes the part to leave the I/O state, abort the output and begin a new conversion.

Serial Clock Idle-High (CPOL = 1) Examples

In Figure 6, following a conversion cycle the LTC2470/LTC2472 automatically enter the NAP mode with the ADC powered down. The ADC's reference will power down if the SLP bit was set high prior to the just completed conversion and \overline{CS} is HIGH. Once \overline{CS} goes low, both the reference and ADC are powered up.

When the conversion is complete, the user applies 16 clock cycles to transfer the result. The \overline{CS} rising edge is then used to initiate a new conversion.

The operation example of Figure 7 is identical to that of Figure 6, except the new conversion cycle is triggered by the falling edge of the serial clock (SCK).

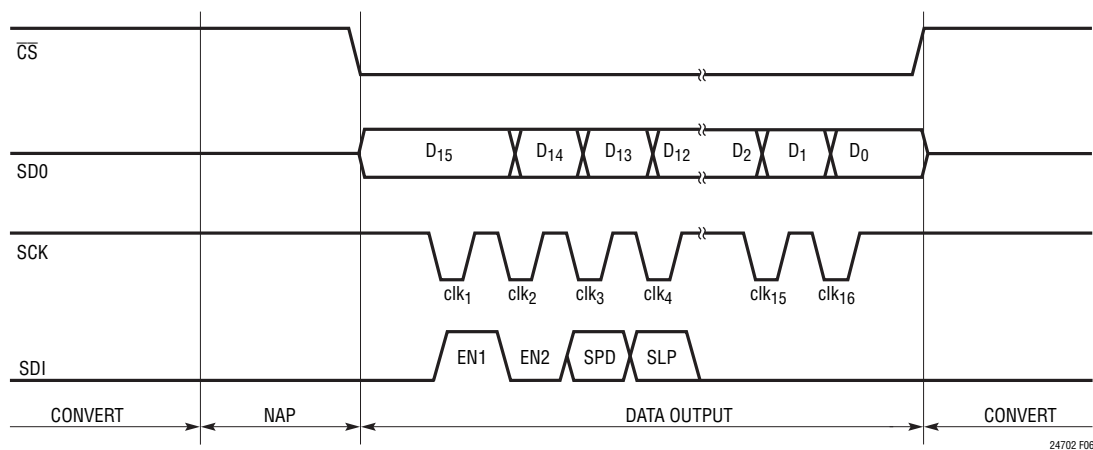

**Figure 6. Idle-High (CPOL = 1) Serial Clock Operation Example.
The Rising Edge of \overline{CS} Starts a New Conversion**

APPLICATIONS INFORMATION

Serial Clock Idle-Low (CPOL = 0) Examples

In Figure 8, following a conversion cycle the LTC2470/LTC2472 automatically enters the NAP state. The device reference will power down if the SLP bit was set high prior to the just completed conversion and \overline{CS} is HIGH. Once \overline{CS} goes low, the reference powers up. The user determines data availability (and the end of conversion) based upon external timing. The user then pulls \overline{CS} low ($\overline{CS} = \downarrow$) and uses 16 clock cycles to transfer the result. Following the 16th rising edge of the clock, \overline{CS} is pulled high ($\overline{CS} = \uparrow$), which triggers a new conversion.

The timing diagram in Figure 9 is identical to that of Figure 8, except in this case a new conversion is triggered by SCK. The 16th SCK falling edge triggers a new conversion cycle and the \overline{CS} signal is subsequently pulled high.

Examples of Aborting Cycle using \overline{CS}

For some applications, the user may wish to abort the I/O cycle and begin a new conversion. If the LTC2470/LTC2472 are in the data input/output state, a \overline{CS} rising edge clears

the remaining data bits from the output register, aborts the output cycle and triggers a new conversion. Figure 10 shows an example of aborting an I/O with idle-high (CPOL = 1) and Figure 11 shows an example of aborting an I/O with idle-low (CPOL = 0).

A new conversion cycle can be triggered using the \overline{CS} signal without having to generate any serial clock pulses as shown in Figure 12. If SCK is held at a low logic level, after the end of a conversion cycle, a new conversion operation can be triggered by pulling \overline{CS} low and then high. When \overline{CS} is pulled low ($\overline{CS} = \text{LOW}$), SDO will output the sign (D15) of the result of the just completed conversion. While a low logic level is maintained at SCK pin and \overline{CS} is subsequently pulled high ($\overline{CS} = \text{HIGH}$) the remaining 15 bits of the result (D14:D0) are discarded and a new conversion cycle starts.

Following the aborted I/O, additional clock pulses in the CONVERT state are acceptable, but excessive signal transitions on SCK can potentially create noise on the ADC during the conversion, and thus may negatively influence the conversion accuracy.

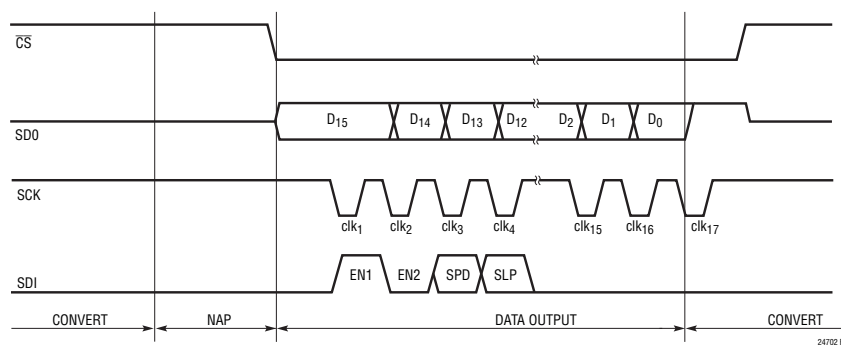

Figure 7. Idle-High (CPOL = 1) Clock Operation Example. A 17th Clock Pulse is Used to Trigger a New Conversion Cycle

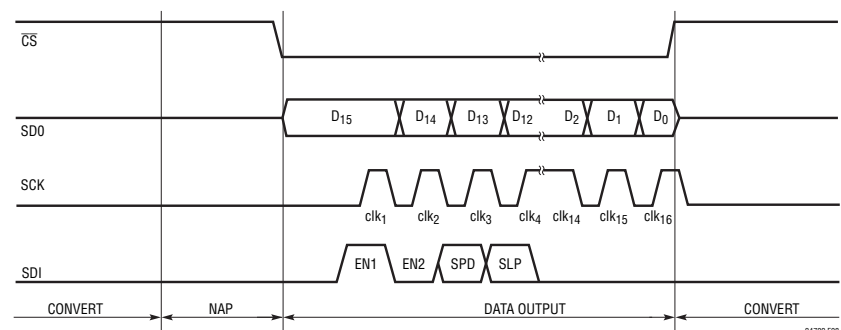

Figure 8. Idle-Low (CPOL = 0) Clock. \overline{CS} Triggers a New Conversion

APPLICATIONS INFORMATION

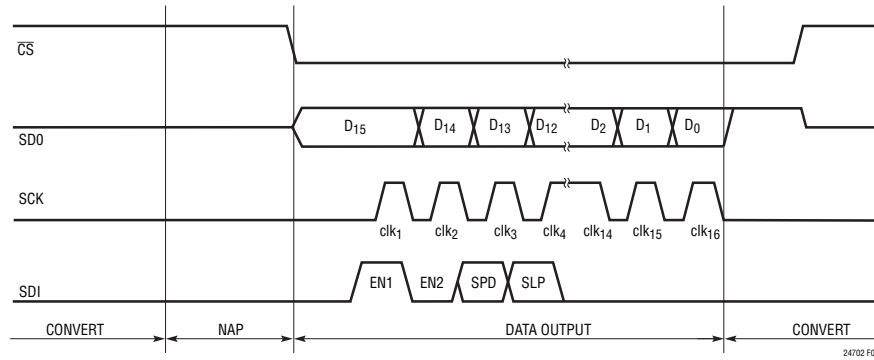

Figure 9. Idle-Low (CPOL = 0) Clock. The 16th SCK Falling Edge Triggers a New Conversion

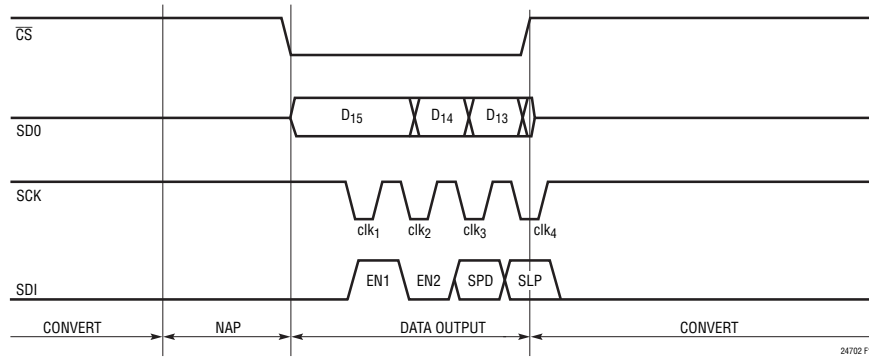

Figure 10. Idle-High (CPOL = 1) Clock and Aborted I/O Example

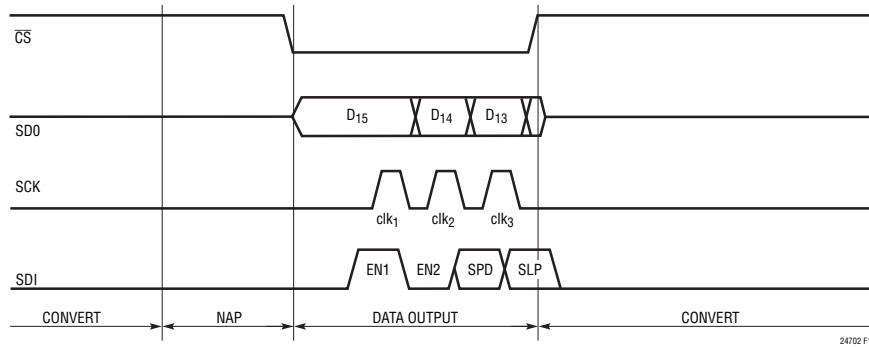

Figure 11. Idle-Low (CPOL = 0) Clock and Aborted I/O Example

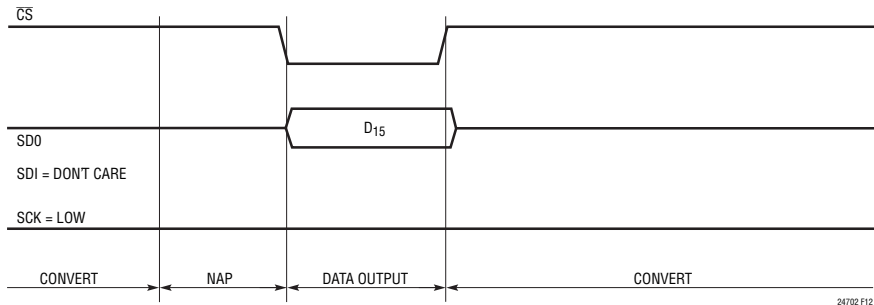

Figure 12. Idle-Low (CPOL = 0) Clock and Minimum Data Output Length Example

APPLICATIONS INFORMATION

2-Wire Operation

The 2-wire operation modes, while reducing the number of required control signals, should be used only if the LTC2470/LTC2472 low power sleep capability is not required. In addition the option to abort serial data transfers is no longer available. Hardware \overline{CS} to GND for 2-wire operation. Tie SDI LOW for 208sps output rate and SDI HIGH for 833sps output rate.

Figure 13 shows a 2-wire operation sequence which uses an idle-high (CPOL = 1) serial clock signal. Following a conversion cycle, the ADC enters the data output state and the SDO output transitions from HIGH to LOW. Subsequently 16 clock pulses are applied to the SCK input in order to serially shift the 16 bit result. Finally, the 17th clock pulse is applied to the SCK input in order to trigger a new conversion cycle.

Figure 14 shows a 2-wire operation sequence which uses an idle-low (CPOL = 0) serial clock signal. Following a conversion cycle, the LTC2470/LTC2472 enters the DATA OUTPUT state. At this moment the SDO pin outputs the

sign (D15) of the conversion result. The user must use external timing in order to determine the end of conversion and result availability. Subsequently 16 clock pulses are applied to SCK in order to serially shift the 16-bit result. The 16th clock falling edge triggers a new conversion cycle. Tie SDI LOW for 208sps output rate and SDI HIGH for 833sps output rate.

PRESERVING THE CONVERTER ACCURACY

The LTC2470/LTC2472 are designed to minimize the conversion result's sensitivity to device decoupling, PCB layout, anti-aliasing circuits, line and frequency perturbations. Nevertheless, in order to preserve the high accuracy capability of this part, some simple precautions are desirable.

Digital Signal Levels

Due to the nature of CMOS logic, it is advisable to keep input digital signals near GND or V_{CC} . Voltages in the range of 0.5V to $V_{CC} - 0.5V$ may result in additional current leakage

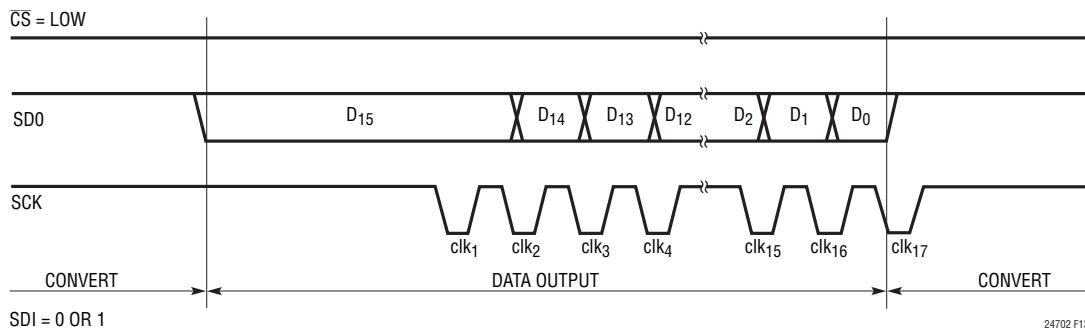

Figure 13. 2-Wire, Idle-High (CPOL = 1) Serial Clock, Operation Example

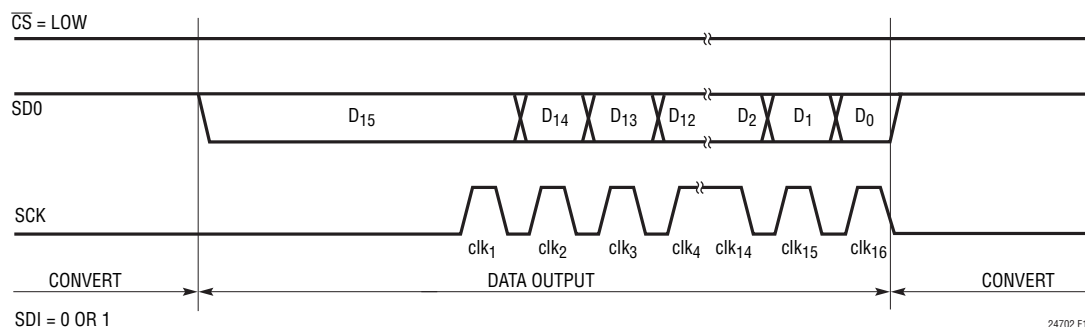

Figure 14. 2-Wire, Idle-Low (CPOL = 0) Serial Clock Operation Example

APPLICATIONS INFORMATION

from the part. Undershoot and overshoot should also be minimized, particularly while the chip is converting. It is thus beneficial to keep edge rates of about 10ns and limit overshoot and undershoot to less than 0.3V.

Noisy external circuitry can potentially impact the output under 2-wire operation. In particular, it is possible to get the LTC2470/LTC2472 into an unknown state if an SCK pulse is missed or noise triggers an extra SCK pulse. In this situation, it is impossible to distinguish SDO = 1 (indicating conversion in progress) from valid “1” data bits. A method to prevent this from happening is to read 32 bits each cycle instead of 16 and ignoring the last 16 data bits. In the case where a noisy bus leads to an unknown SCK clock count, the extra 16 SCK clock pulses will force a new conversion and place the device in a known state.

Driving V_{CC} and GND

In relation to the V_{CC} and GND pins, the LTC2470/LTC2472 combines internal high frequency decoupling with damping elements, which reduce the ADC performance sensitivity to PCB layout and external components. Nevertheless, the very high accuracy of this converter is best preserved by careful low and high frequency power supply decoupling.

A 0.1 μ F, high quality, ceramic capacitor in parallel with a 10 μ F low ESR ceramic capacitor should be connected between the V_{CC} and GND pins, as close as possible to the package. The 0.1 μ F capacitor should be placed closest to the ADC package. It is also desirable to avoid any via in the circuit path, starting from the converter V_{CC} pin, passing through these two decoupling capacitors, and returning to the converter GND pin. The area encompassed by this circuit path, as well as the path length, should be minimized.

As shown in Figure 15, REF⁻ is used as the negative reference voltage input to the ADC. This pin can be tied directly to ground or Kelvin sensed to sensor ground. In the case where REF⁻ is used as a sense input, it should be bypassed to ground with a 0.1 μ F ceramic capacitor in parallel with a 10 μ F low ESR ceramic capacitor.

Very low impedance ground and power planes, and star connections at both V_{CC} and GND pins, are preferable. The V_{CC} pin should have two distinct connections: the first to the decoupling capacitors described above, and the second to the ground return for the power supply voltage source.

REFOUT and COMP

The on chip 1.25V reference is internally tied to the converter's reference input and is output to the REFOUT pin. A 0.1 μ F capacitor should be placed on the REFOUT pin. It is possible to reduce this capacitor, but the transition noise increases (see Figure 4). A 0.1 μ F capacitor should also be placed on the COMP pin. This pin is tied to an internal point in the reference and is used for stability.

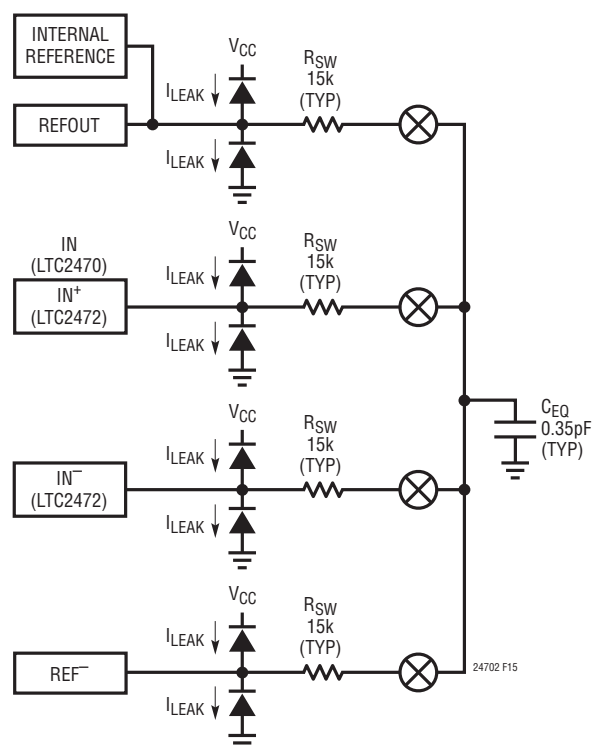

Figure 15. LTC2470/LTC2472 Analog Input/Reference Equivalent Circuit

APPLICATIONS INFORMATION

In order for the reference to remain stable, the capacitor placed on the COMP pin must be greater than or equal to the capacitor tied to the REFOUT pin. The REFOUT pin cannot be overridden by an external voltage.

Depending on the size of the capacitors tied to the REFOUT and COMP pins, the internal reference has a corresponding start up time. This start up time is typically 12ms when 0.1 μ F capacitors are used. The first conversion following power up can be discarded using the data abort command or simply read and ignored. Depending on the value chosen for C_{COMP} and C_{REFOUT} , the reference startup can take more than one conversion period, see Figure 3. If the startup time is less than 1.2ms (833sps output rate) or 4.8ms (208sps output rate) then conversions following the first period are accurate to the device specifications. If the startup time exceeds 1.2ms or 4.8ms then the user can wait the appropriate time or use the fixed conversion period as a startup timer by ignoring results within the unsettled period. Once the reference has settled all subsequent conversion results are valid. If the user places the device into the sleep mode ($SLP = 1$, reference powered down) the reference will require a startup time proportional to the value of C_{COMP} and C_{REFOUT} , see Figure 3.

If the reference is put to sleep (program $SLP = 1$ and $\overline{CS} = 1$) the reference is powered down after the next conversion. This last conversion result is valid. On \overline{CS} falling edge, the reference is powered back up. In order to ensure the reference output has settled before the next conversion, the power up time can be extended by delaying the data read after the falling edge of \overline{CS} . Once all 16 bits are read from the device or \overline{CS} is brought HIGH, the next conversion automatically begins. In the default operation, the reference remains powered up at the conclusion of the conversion cycle.

Driving V_{IN^+} and V_{IN^-}

The input drive requirements can best be analyzed using the equivalent circuit of Figure 16. The input signal V_{SIG} is connected to the ADC input pins (IN^+ and IN^-) through an equivalent source resistance R_S . This resistor includes both

the actual generator source resistance and any additional optional resistors connected to the input pins. Optional input capacitors C_{IN} are also connected to the ADC input pins. This capacitor is placed in parallel with the input parasitic capacitance C_{PAR} . This parasitic capacitance includes elements from the printed circuit board (PCB)

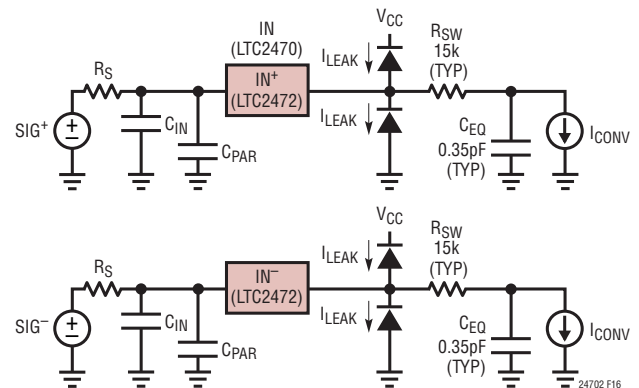

Figure 16. LTC2470/LTC2472 Input Drive Equivalent Circuit

and the associated input pin of the ADC. Depending on the PCB layout, C_{PAR} has typical values between 2pF and 15pF. In addition, the equivalent circuit of Figure 16 includes the converter equivalent internal resistor R_{SW} and sampling capacitor C_{EQ} .

There are some immediate trade-offs in R_S and C_{IN} without needing a full circuit analysis. Increasing R_S and C_{IN} can give the following benefits:

- 1) Due to the LTC2470/LTC2472's input sampling algorithm, the input current drawn by either IN^+ or IN^- over a conversion cycle is typically 50nA. A high $R_S \cdot C_{IN}$ attenuates the high frequency components of the input current, and R_S values up to 1k result in <1LSB error.
- 2) The bandwidth from V_{SIG} is reduced at the input pins (IN^+ , IN^- or IN). This bandwidth reduction isolates the ADC from high frequency signals, and as such provides simple anti-aliasing and input noise reduction.
- 3) Switching transients generated by the ADC are attenuated before they go back to the signal source.

APPLICATIONS INFORMATION

- 4) A large C_{IN} gives a better AC ground at the input pins, helping reduce reflections back to the signal source.
- 5) Increasing R_S protects the ADC by limiting the current during an outside-the-rails fault condition.

There is a limit to how large $R_S \cdot C_{IN}$ should be for a given application. Increasing R_S beyond a given point increases the voltage drop across R_S due to the input current, to the point that significant measurement errors exist. Additionally, for some applications, increasing the $R_S \cdot C_{IN}$ product too much may unacceptably attenuate the signal at frequencies of interest.

For most applications, it is desirable to implement C_{IN} as a high-quality 0.1 μ F ceramic capacitor and to set $R_S \leq 1k$. This capacitor should be located as close as possible to the actual IN^+ , IN^- and IN package pins. Furthermore, the area encompassed by this circuit path, as well as the path length, should be minimized.

In the case of a 2-wire sensor that is not remotely grounded, it is desirable to split R_S and place series resistors in the ADC input line as well as in the sensor ground return line, which should be tied to the ADC GND pin using a star connection topology.

Figure 17 shows the measured LTC2472 INL vs Input Voltage as a function of R_S value with an input capacitor $C_{IN} = 0.1\mu$ F.

In some cases, R_S can be increased above these guidelines. The input current is zero when the ADC is either in sleep or I/O modes. Thus, if the time constant of the input RC circuit $\tau = R_S \cdot C_{IN}$, is of the same order of magnitude or longer than the time periods between actual conversions, then one can consider the input current to be reduced correspondingly.

These considerations need to be balanced out by the input signal bandwidth. The 3dB bandwidth $\approx 1/(2\pi R_S C_{IN})$.

Finally, if the recommended choice for C_{IN} is unacceptable for the user's specific application, an alternate strategy is to eliminate C_{IN} and minimize C_{PAR} and R_S . In practical terms, this configuration corresponds to a low impedance sensor

directly connected to the ADC through minimum length traces. Actual applications include current measurements through low value sense resistors, temperature measurements, low impedance voltage source monitoring, and so on. The resultant INL vs V_{IN} is shown in Figure 18. The measurements of Figure 18 include a capacitor C_{PAR} corresponding to a minimum sized layout pad and a minimum width input trace of about 1 inch length.

Signal Bandwidth, Transition Noise and Noise Equivalent Input Bandwidth

The LTC2470/LTC2472 include a sinc² type digital filter. The first notch is located at 416Hz if the 208sps output rate is selected and 1666Hz if the 833sps output rate is selected. The calculated input signal attenuation vs. frequency over a wide frequency range is shown in Figure 19. The calculated input signal attenuation vs. frequency at low frequencies is shown in Figure 20. The converter noise level is about 3μ V_{RMS} and can be modeled by a white noise source connected at the input of a noise-free converter.

On a related note, the LTC2472 uses two separate A/D converters to digitize the positive and negative inputs. Each of these A/D converters has 3μ V_{RMS} transition noise. If one of the input voltages is within this small transition noise band, then the output will fluctuate one bit, regardless of the value of the other input voltage. If both of the input voltages are within their transition noise bands, the output can fluctuate 2 bits.

For a simple system noise analysis, the V_{IN} drive circuit can be modeled as a single-pole equivalent circuit characterized by a pole location f_i and a noise spectral density n_i . If the converter has an unlimited bandwidth, or at least a bandwidth substantially larger than f_i , then the total noise contribution of the external drive circuit would be:

$$V_n = n_i \sqrt{\pi/2 \cdot f_i}$$

Then, the total system noise level can be estimated as the square root of the sum of (V_n^2) and the square of the LTC2470/LTC2472 noise floor.

APPLICATIONS INFORMATION

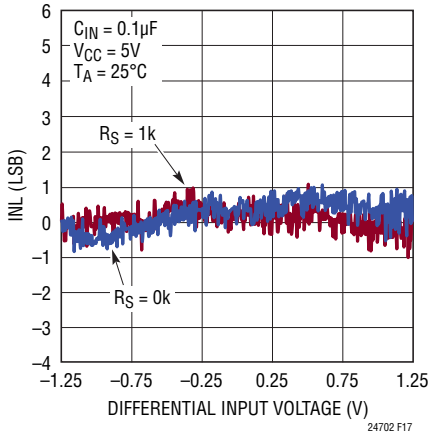

Figure 17. Measured INL vs Input Voltage

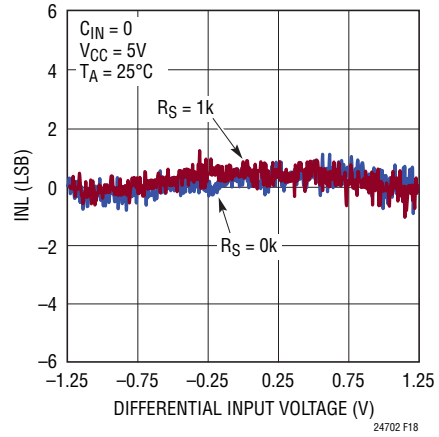

Figure 18. Measured INL vs Input Voltage

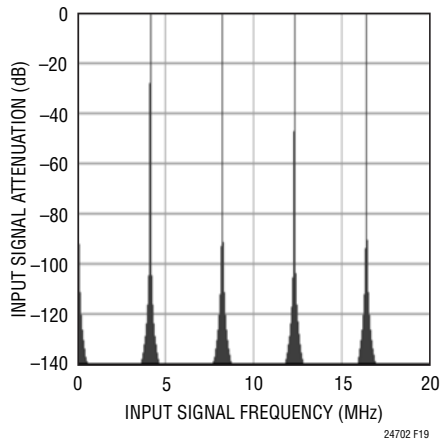

Figure 19. LTC2472 Input Signal Attenuation vs Frequency (208sps Mode)

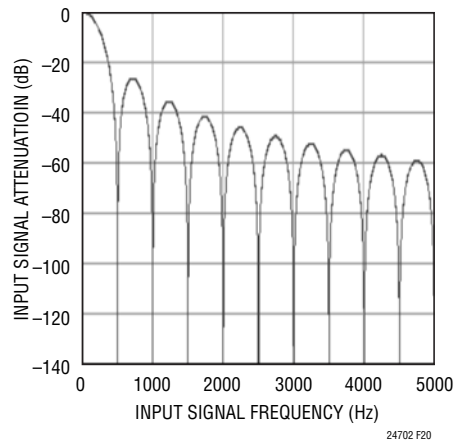

Figure 20. LTC2472 Input Signal Attenuation vs Frequency (208sps Mode)

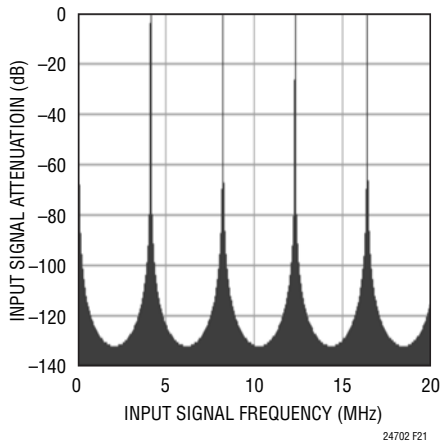

Figure 21. LTC2472 Input Signal Attenuation vs Frequency (833sps Mode)

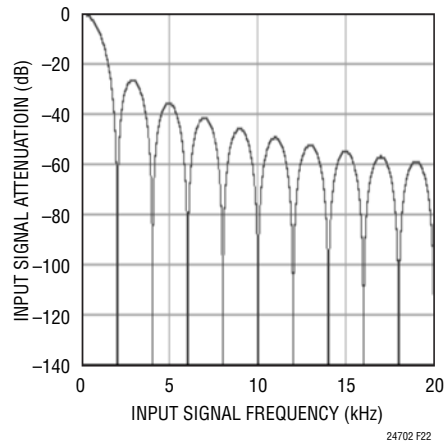
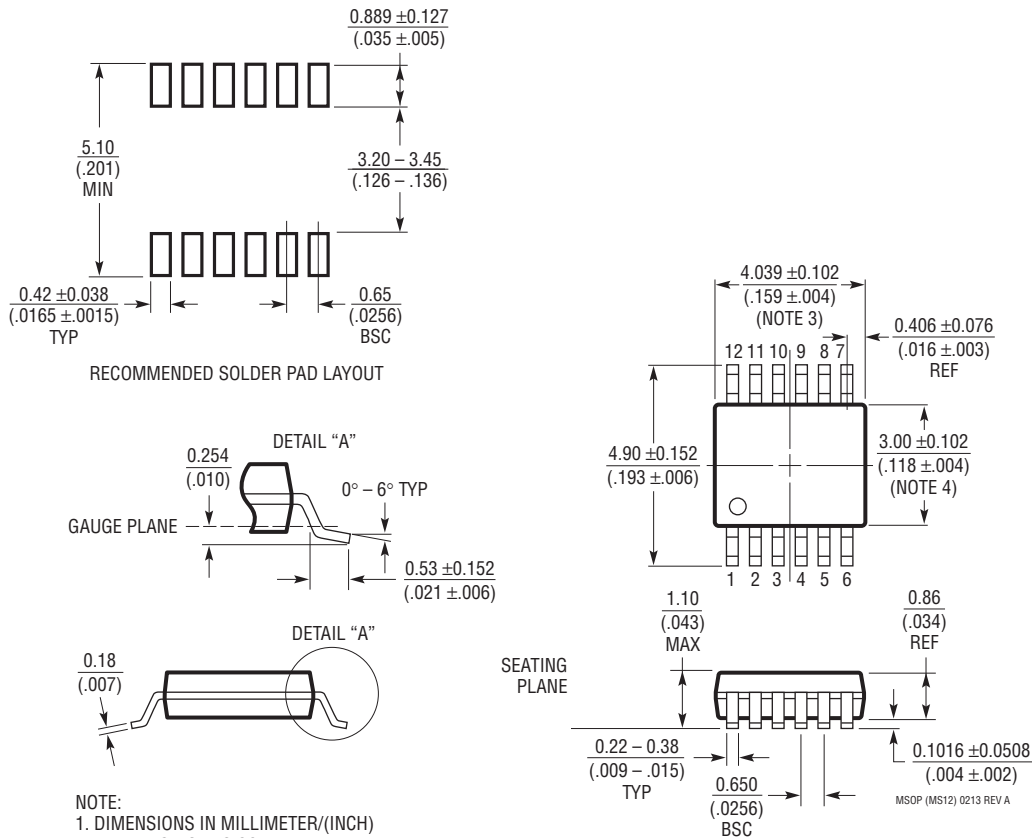

Figure 22. LTC2472 Input Signal Attenuation vs Frequency (833sps Mode)

PACKAGE DESCRIPTION

Please refer to <http://www.linear.com/designtools/packaging/> for the most recent package drawings.

MS Package
12-Lead Plastic MSOP
 (Reference LTC DWG # 05-08-1668 Rev A)



- NOTE:
1. DIMENSIONS IN MILLIMETER/(INCH)
 2. DRAWING NOT TO SCALE
 3. DIMENSION DOES NOT INCLUDE MOLD FLASH, PROTRUSIONS OR GATE BURRS.
MOLD FLASH, PROTRUSIONS OR GATE BURRS SHALL NOT EXCEED 0.152mm (.006") PER SIDE
 4. DIMENSION DOES NOT INCLUDE INTERLEAD FLASH OR PROTRUSIONS.
INTERLEAD FLASH OR PROTRUSIONS SHALL NOT EXCEED 0.152mm (.006") PER SIDE
 5. LEAD COPLANARITY (BOTTOM OF LEADS AFTER FORMING) SHALL BE 0.102mm (.004") MAX

MSOP (MS12) 0213 REV A

REVISION HISTORY

REV	DATE	DESCRIPTION	PAGE NUMBER
A	9/13	Clarified maximum operating output rate as 208sps/833sps	Global
B	1/14	Removed No Missing Codes Resolution	1, 3

LTC2470/LTC2472

TYPICAL APPLICATION

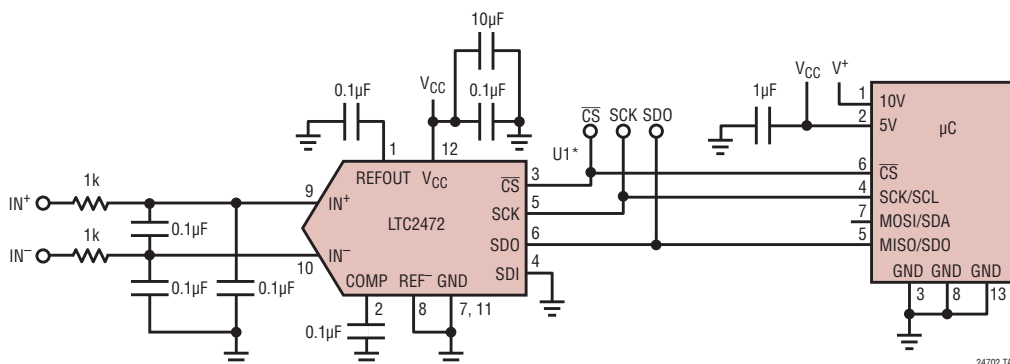

RELATED PARTS

PART NUMBER	DESCRIPTION	COMMENTS
LTC1860/LTC1861	12-Bit, 5V, 1-/2-Channel 250ksps SAR ADC in MSOP	850µA at 250ksps, 2µA at 1ksps, SO-8 and MSOP Packages
LTC1860L/LTC1861L	12-Bit, 3V, 1-/2-Channel 150ksps SAR ADC	450µA at 150ksps, 10µA at 1ksps, SO-8 and MSOP Packages
LTC1864/LTC1865	16-Bit, 5V, 1-/2-Channel 250ksps SAR ADC in MSOP	850µA at 250ksps, 2µA at 1ksps, SO-8 and MSOP Packages
LTC1864L/LTC1865L	16-bit, 3V, 1-/2-Channel 150ksps SAR ADC	450µA at 150ksps, 10µA at 1ksps, SO-8 and MSOP Packages
LTC2360	12-Bit, 100ksps SAR ADC	3V Supply, 1.5mW at 100ksps, TSOT 6-pin/8-pin Packages
LTC2440	24-Bit No Latency $\Delta\Sigma^T$ ADC	200nV _{RMS} Noise, 4kHz Output Rate, 15ppm INL
LTC2480	16-Bit, Differential Input, No Latency $\Delta\Sigma$ ADC, with PGA, Temp. Sensor, SPI	Easy-Drive Input Current Cancellation, 600nV _{RMS} Noise, Tiny 10-Lead DFN Package
LTC2481	16-Bit, Differential Input, No Latency $\Delta\Sigma$ ADC, with PGA, Temp. Sensor, I ² C	Easy-Drive Input Current Cancellation, 600nV _{RMS} Noise, Tiny 10-Lead DFN Package
LTC2482	16-Bit, Differential Input, No Latency $\Delta\Sigma$ ADC, SPI	Easy-Drive Input Current Cancellation, 600nV _{RMS} Noise, Tiny 10-Lead DFN Package
LTC2483	16-Bit, Differential Input, No Latency $\Delta\Sigma$ ADC, I ² C	Easy-Drive Input Current Cancellation, 600nV _{RMS} Noise, Tiny 10-Lead DFN Package
LTC2484	24-Bit, Differential Input, No Latency $\Delta\Sigma$ ADC, SPI with Temp. Sensor	Easy-Drive Input Current Cancellation, 600nV _{RMS} Noise, Tiny 10-Lead DFN Package
LTC2485	24-Bit, Differential Input, No Latency $\Delta\Sigma$ ADC, I ² C with Temp. Sensor	Easy-Drive Input Current Cancellation, 600nV _{RMS} Noise, Tiny 10-Lead DFN Package
LTC6241	Dual, 18MHz, Low Noise, Rail-to-Rail Op Amp	550nV _{p-p} Noise, 125µV Offset Max
LTC2450	Easy-to-Use, Ultra-Tiny 16-Bit ADC, SPI, 0V to 5.5V Input Range	2 LSB INL, 50nA Sleep current, Tiny 2mm × 2mm DFN-6 Package, 30Hz Output Rate
LTC2450-1	Easy-to-Use, Ultra-Tiny 16-Bit ADC, SPI, 0V to 5.5V Input Range	2 LSB INL, 50nA Sleep Current, Tiny 2mm × 2mm DFN-6 Package, 60Hz Output Rate
LTC2451	Easy-to-Use, Ultra-Tiny 16-Bit ADC, I ² C, 0V to 5.5V Input Range	2 LSB INL, 50nA Sleep Current, Tiny 3mm × 2mm DFN-8 or TSOT Package, Programmable 30Hz/60Hz Output Rates
LTC2452	Easy-to-Use, Ultra-Tiny 16-Bit Differential ADC, SPI, ±5.5V Input Range	2 LSB INL, 50nA Sleep Current, Tiny 3mm × 2mm DFN-8 or TSOT Package
LTC2453	Easy-to-Use, Ultra-Tiny 16-Bit Differential ADC, I ² C, ±5.5V Input Range	2 LSB INL, 50nA Sleep Current, Tiny 3mm × 2mm DFN-8 or TSOT Package
LTC2460	Ultra-Tiny 16-Bit $\Delta\Sigma$ ADC with 10ppm Reference	Pin and Software Compatible with LTC2470, 60Hz Output Rate
LTC2462	Ultra-Tiny 16-Bit $\Delta\Sigma$ ADC with 10ppm Reference	Pin and Software Compatible with LTC2472, 60Hz Output Rate

24702fb

Looking for pricing, stock, or lifecycle information?

Click below to explore more details on WIN SOURCE:

 [View LTC2472CMS#PBF on WIN SOURCE](#)

 [Linear Technology](#) Information

Optimize Your Supply Chain with WIN SOURCE Solutions

-  Global Sourcing Solution
-  Obsolete Management
-  Cost Control Management
-  Shortage Management
-  Alternative Solution
-  Excess Inventory Management