



**THE DATASHEET OF
LTC2424IG#PBF**



FEATURES

- Pin Compatible 4-/8-Channel 20-Bit ADCs
- 8ppm INL, No Missing Codes at 20 Bits
- 4ppm Full-Scale Error and 0.5ppm Offset
- 1.2ppm Noise
- Digital Filter Settles in a Single Cycle. Each Conversion is Accurate, Even After Changing Channels
- Fast Mode: 16-Bit Noise, 12-Bit TUE at 100sps
- Internal Oscillator—No External Components Required
- 110dB Min, 50Hz/60Hz Notch Filter
- Reference Input Voltage: 0.1V to V_{CC}
- Live Zero—Extended Input Range Accommodates 12.5% Overrange and Underrange
- Single Supply 2.7V to 5.5V Operation
- Low Supply Current (200 μ A) and Auto Shutdown
- Can Be Interchanged with 24-Bit LTC2404/LTC2408 if ZS_{SET} Pin is Grounded

APPLICATIONS

- Weight Scales
- Direct Temperature Measurement
- Gas Analyzers
- Strain-Gage Transducers
- Instrumentation
- Data Acquisition
- Industrial Process Control
- 4-Digit DVMs

DESCRIPTION

The LTC[®]2424/LTC2428 are 4-/8-channel 2.7V to 5.5V micropower 20-bit A/D converters with an integrated oscillator, 8ppm INL and 1.2ppm RMS noise. They use delta-sigma technology and provide single cycle digital filter settling time (no latency delay) for multiplexed applications. The first conversion after the channel is changed is always valid. Through a single pin the LTC2424/LTC2428 can be configured for better than 110dB rejection at 50Hz or 60Hz \pm 2%, or can be driven by an external oscillator for a user defined rejection frequency in the range 1Hz to 800Hz. The internal oscillator requires no external frequency setting components.

The converters accept any external reference voltage from 0.1V to V_{CC} . With their extended input conversion range of $-12.5\% V_{REF}$ to $112.5\% V_{REF}$ ($V_{REF} = FS_{SET} - ZS_{SET}$) the LTC2424/LTC2428 smoothly resolve the offset and overrange problems of preceding sensors or signal conditioning circuits.

The LTC2424/LTC2428 communicate through a flexible 4-wire digital interface which is compatible with SPI and MICROWIRE[™] protocols.

 LTC and LT are registered trademarks of Linear Technology Corporation. No Latency $\Delta\Sigma$ is a trademark of Linear Technology Corporation. MICROWIRE is a trademark of National Semiconductor Corporation.

TYPICAL APPLICATION

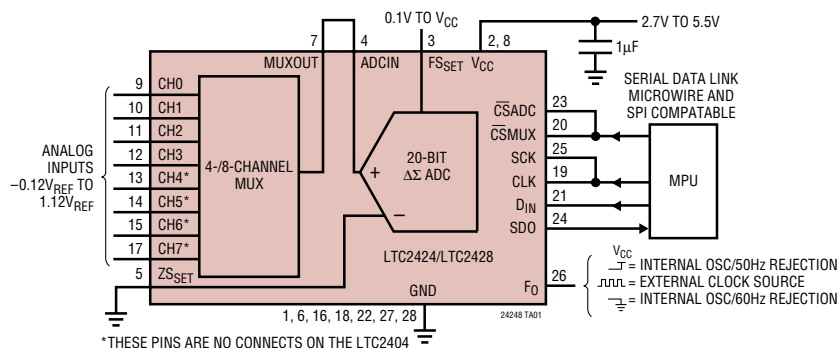

Total Unadjusted Error (3V Supply)

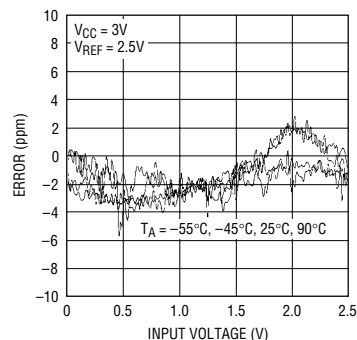

LTC2424/LTC2428

ABSOLUTE MAXIMUM RATINGS

(Notes 1, 2)

Supply Voltage (V_{CC}) to GND -0.3V to 7V
 Analog Input Voltage to GND -0.3V to ($V_{CC} + 0.3V$)
 Reference Input Voltage to GND .. -0.3V to ($V_{CC} + 0.3V$)
 Digital Input Voltage to GND -0.3V to ($V_{CC} + 0.3V$)
 Digital Output Voltage to GND -0.3V to ($V_{CC} + 0.3V$)

Operating Temperature Range
 LTC2424C/LTC2428C 0°C to 70°C
 LTC2424I/LTC2428I -40°C to 85°C
 Storage Temperature Range -65°C to 150°C
 Lead Temperature (Soldering, 10 sec) 300°C

PACKAGE/ORDER INFORMATION

TOP VIEW	ORDER PART NUMBER	TOP VIEW	ORDER PART NUMBER
<p>G PACKAGE 28-LEAD PLASTIC SSOP $T_{JMAX} = 125^{\circ}C, \theta_{JA} = 130^{\circ}C/W$</p>	LTC2424CG LTC2424IG	<p>G PACKAGE 28-LEAD PLASTIC SSOP $T_{JMAX} = 125^{\circ}C, \theta_{JA} = 130^{\circ}C/W$</p>	LTC2428CG LTC2428IG

Consult factory for parts specified with wider operating temperature ranges.

CONVERTER CHARACTERISTICS

The ● denotes specifications which apply over the full operating temperature range, otherwise specifications are at $T_A = 25^{\circ}C$. (Notes 3, 4)

PARAMETER	CONDITIONS	MIN	TYP	MAX	UNITS
Resolution (No Missing Codes)	$0.1V \leq V_{REF} \leq V_{CC}$, (Note 5)	●	20		Bits
Integral Nonlinearity	$V_{REF} = 2.5V$ (Note 6)	●	4	10	ppm of V_{REF}
	$V_{REF} = 5V$ (Note 6)	●	8	20	ppm of V_{REF}
Integral Nonlinearity (Fast Mode)	$2.5V < V_{REF} < V_{CC}$, 100 Samples/Second, $f_0 = 2.051MHz$	●	40	250	ppm of V_{REF}
Offset Error	$2.5V \leq V_{REF} \leq V_{CC}$	●	0.5	10	ppm of V_{REF}
Offset Error (Fast Mode)	$2.5V < V_{REF} < 5V$, 100 Samples/Second, $f_0 = 2.051MHz$		3		ppm of V_{REF}
Offset Error Drift	$2.5V \leq V_{REF} \leq V_{CC}$		0.04		ppm of $V_{REF}/^{\circ}C$
Full-Scale Error	$2.5V \leq V_{REF} \leq V_{CC}$	●	4	15	ppm of V_{REF}
Full-Scale Error (Fast Mode)	$2.5V < V_{REF} < 5V$, 100 Samples/Second, $f_0 = 2.051MHz$		10		ppm of V_{REF}
Full-Scale Error Drift	$2.5V \leq V_{REF} \leq V_{CC}$		0.04		ppm of $V_{REF}/^{\circ}C$

CONVERTER CHARACTERISTICS

The ● denotes specifications which apply over the full operating temperature range, otherwise specifications are at $T_A = 25^\circ\text{C}$. (Notes 3, 4)

PARAMETER	CONDITIONS	MIN	TYP	MAX	UNITS
Total Unadjusted Error	$V_{REF} = 2.5V$ $V_{REF} = 5V$		8 16		ppm of V_{REF} ppm of V_{REF}
Output Noise	$V_{IN} = 0V$, $V_{REF} = 5V$ (Note 13)		6		μV_{RMS}
Output Noise (Fast Mode)	$V_{REF} = 5V$, 100 Samples/Second, $f_0 = 2.051\text{MHz}$		20		μV_{RMS}
Normal Mode Rejection 60Hz $\pm 2\%$	(Note 7)	● 110	130		dB
Normal Mode Rejection 50Hz $\pm 2\%$	(Note 8)	● 110	130		dB
Power Supply Rejection, DC	$V_{REF} = 2.5V$, $V_{IN} = 0V$		100		dB
Power Supply Rejection, 60Hz $\pm 2\%$	$V_{REF} = 2.5V$, $V_{IN} = 0V$, (Notes 7, 16)		110		dB
Power Supply Rejection, 50Hz $\pm 2\%$	$V_{REF} = 2.5V$, $V_{IN} = 0V$, (Notes 8, 16)		110		dB

ANALOG INPUT AND REFERENCE

The ● denotes specifications which apply over the full operating temperature range, otherwise specifications are at $T_A = 25^\circ\text{C}$. (Note 3)

SYMBOL	PARAMETER	CONDITIONS	MIN	TYP	MAX	UNITS
V_{IN}	Input Voltage Range	(Note 14)	● $-0.125 \cdot V_{REF}$		$1.125 \cdot V_{REF}$	V
V_{REF}	Reference Voltage Range		● 0.1		V_{CC}	V
$C_{S(IN)}$	Input Sampling Capacitance			1		pF
$C_{S(REF)}$	Reference Sampling Capacitance			1.5		pF
$I_{IN(LEAK)}$	Input Leakage Current	$\overline{CS} = V_{CC}$	● -100	1	100	nA
$I_{REF(LEAK)}$	Reference Leakage Current	$V_{REF} = 2.5V$, $\overline{CS} = V_{CC}$	● -100	1	100	nA
$I_{IN(MUX)}$	On Channel Leakage Current	$V_S = 2.5V$ (Note 15)	●		± 20	nA
R_{ON}	MUX On-Resistance	$I_{OUT} = 1\text{mA}$, $V_{CC} = 2.7V$ $I_{OUT} = 1\text{mA}$, $V_{CC} = 5V$	●	250	300	Ω
			●	120	250	Ω
	MUX ΔR_{ON} vs Temperature			0.5		%/ $^\circ\text{C}$
	ΔR_{ON} vs V_S (Note 15)			20		%
$I_{S(OFF)}$	MUX Off Input Leakage	Channel Off, $V_S = 2.5V$	●		± 20	nA
$I_{D(OFF)}$	MUX Off Output Leakage	Channel Off, $V_D = 2.5V$	●		± 20	nA
t_{OPEN}	MUX Break-Before-Make Interval			290		ns
t_{ON}	Enable Turn-On Time	$V_S = 1.5V$, $R_L = 3.4k$, $C_L = 15\text{pF}$		490		ns
t_{OFF}	Enable Turn-Off Time	$V_S = 1.5V$, $R_L = 3.4k$, $C_L = 15\text{pF}$		190		ns
$C_{S(OFF)}$	Input Off Capacitance (MUX)			10		pF
$C_{D(OFF)}$	Output Off Capacitance (MUX)			10		pF
	MUX OFF Isolation Channel-to-Channel	DC		120		dB
		at 1Hz		120		dB
		at $f_S = 15,360\text{Hz}$		120		dB

DIGITAL INPUTS AND DIGITAL OUTPUTS

The ● denotes specifications which apply over the full operating temperature range, otherwise specifications are at $T_A = 25^\circ\text{C}$. (Note 3)

SYMBOL	PARAMETER	CONDITIONS		MIN	TYP	MAX	UNITS
V_{IH}	High Level Input Voltage \overline{CS} , F_0	$2.7V \leq V_{CC} \leq 5.5V$	●	2.5			V
		$2.7V \leq V_{CC} \leq 3.3V$		2.0			V
V_{IL}	Low Level Input Voltage \overline{CS} , F_0	$4.5V \leq V_{CC} \leq 5.5V$	●			0.8	V
		$2.7V \leq V_{CC} \leq 5.5V$				0.6	V
V_{IH}	High Level Input Voltage SCK	$2.7V \leq V_{CC} \leq 5.5V$ (Note 9)	●	2.5			V
		$2.7V \leq V_{CC} \leq 3.3V$ (Note 9)		2.0			V
V_{IL}	Low Level Input Voltage SCK	$4.5V \leq V_{CC} \leq 5.5V$ (Note 9)	●			0.8	V
		$2.7V \leq V_{CC} \leq 5.5V$ (Note 9)				0.6	V
I_{IN}	Digital Input Current \overline{CS} , F_0	$0V \leq V_{IN} \leq V_{CC}$	●	-10		10	μA
I_{IN}	Digital Input Current SCK	$0V \leq V_{IN} \leq V_{CC}$ (Note 9)	●	-10		10	μA
C_{IN}	Digital Input Capacitance \overline{CS} , F_0				10		pF
C_{IN}	Digital Input Capacitance SCK	(Note 9)			10		pF
V_{OH}	High Level Output Voltage SDO	$I_O = -800\mu\text{A}$	●	$V_{CC} - 0.5$			V
V_{OL}	Low Level Output Voltage SDO	$I_O = 1.6\text{mA}$	●			0.4	V
V_{OH}	High Level Output Voltage SCK	$I_O = -800\mu\text{A}$ (Note 10)	●	$V_{CC} - 0.5$			V
V_{OL}	Low Level Output Voltage SCK	$I_O = 1.6\text{mA}$ (Note 10)	●			0.4	V
I_{OZ}	High-Z Output Leakage SDO		●	-10		10	μA
$V_{IN\ HMUX}$	MUX High Level Input Voltage	$V^+ = 3V$	●	2			V
$V_{IN\ LMUX}$	MUX Low Level Input Voltage	$V^+ = 2.4V$	●			0.8	V

POWER REQUIREMENTS

The ● denotes specifications which apply over the full operating temperature range, otherwise specifications are at $T_A = 25^\circ\text{C}$. (Note 3)

SYMBOL	PARAMETER	CONDITIONS		MIN	TYP	MAX	UNITS
V_{CC}	Supply Voltage		●	2.7		5.5	V
I_{CC}	Supply Current (Pin 2) Conversion Mode	$\overline{CS} = 0V$ (Note 12)	●		200	300	μA
		$\overline{CS} = V_{CC}$ (Note 12)	●		20	30	μA
$I_{CC(MUX)}$	Multiplexer Supply Current (Pin 8)	All Logic Inputs Tied Together $V_{IN} = 0V$ or $5V$	●		15	40	μA

TIMING CHARACTERISTICS

The ● denotes specifications which apply over the full operating temperature range, otherwise specifications are at $T_A = 25^\circ\text{C}$. (Note 3)

SYMBOL	PARAMETER	CONDITIONS	MIN	TYP	MAX	UNITS	
f_{EOSC}	External Oscillator Frequency Range	20-Bit Effective Resolution	●	2.56	307.2	kHz	
		12-Bit Effective Resolution	●	2.56k	2.048M	Hz	
t_{HEO}	External Oscillator High Period		●	0.5	390	μs	
t_{LEO}	External Oscillator Low Period		●	0.5	390	μs	
t_{CONV}	Conversion Time	$F_0 = 0\text{V}$	●	130.86	133.53	136.20	ms
		$F_0 = V_{\text{CC}}$	●	157.03	160.23	163.44	ms
		External Oscillator (Note 11)	●	20510/ f_{EOSC} (in kHz)			ms
f_{ISCK}	Internal SCK Frequency	Internal Oscillator (Note 10)		19.2		kHz	
		External Oscillator (Notes 10, 11)		$f_{\text{EOSC}}/8$		kHz	
D_{ISCK}	Internal SCK Duty Cycle	(Note 10)		45	55	%	
f_{ESCK}	External SCK Frequency Range	(Note 9)	●		2000	kHz	
t_{LESCK}	External SCK Low Period	(Note 9)	●	250		ns	
t_{HESCK}	External SCK High Period	(Note 9)	●	250		ns	
$t_{\text{DOUT_ISCK}}$	Internal SCK 24-Bit Data Output Time	Internal Oscillator (Notes 10, 12)	●	1.23	1.25	1.28	ms
		External Oscillator (Notes 10, 11)	●	$192/f_{\text{EOSC}}$ (in kHz)			ms
$t_{\text{DOUT_ESCK}}$	External SCK 24-Bit Data Output Time	(Note 9)	●	$24/f_{\text{ESCK}}$ (in kHz)		ms	
t_1	$\overline{\text{CS}} \downarrow$ to SDO Low Z		●	0	150	ns	
t_2	$\overline{\text{CS}} \uparrow$ to SDO High Z		●	0	150	ns	
t_3	$\overline{\text{CS}} \downarrow$ to SCK \downarrow	(Note 10)	●	0	150	ns	
t_4	$\overline{\text{CS}} \downarrow$ to SCK \uparrow	(Note 9)	●	50		ns	
t_{KQMAX}	SCK \downarrow to SDO Valid		●		200	ns	
t_{KQMIN}	SDO Hold After SCK \downarrow	(Note 5)	●	15		ns	
t_5	SCK Set-Up Before $\overline{\text{CS}} \downarrow$		●	50		ns	
t_6	SCK Hold After $\overline{\text{CS}} \downarrow$		●		50	ns	

Note 1: Absolute Maximum Ratings are those values beyond which the life of the device may be impaired.

Note 2: All voltage values are with respect to GND.

Note 3: $V_{\text{CC}} = 2.7$ to 5.5V unless otherwise specified, source input is 0Ω . $\overline{\text{CS}}_{\text{ADC}} = \overline{\text{CS}}_{\text{MUX}} = \overline{\text{CS}}$. $V_{\text{REF}} = \text{FS}_{\text{SET}} - \text{ZS}_{\text{SET}}$.

Note 4: Internal Conversion Clock source with the F_0 pin tied to GND or to V_{CC} or to external conversion clock source with $f_{\text{EOSC}} = 153600\text{Hz}$ unless otherwise specified.

Note 5: Guaranteed by design, not subject to test.

Note 6: Integral nonlinearity is defined as the deviation of a code from a straight line passing through the actual endpoints of the transfer curve. The deviation is measured from the center of the quantization band.

Note 7: $F_0 = 0\text{V}$ (internal oscillator) or $f_{\text{EOSC}} = 153600\text{Hz} \pm 2\%$ (external oscillator).

Note 8: $F_0 = V_{\text{CC}}$ (internal oscillator) or $f_{\text{EOSC}} = 128000\text{Hz} \pm 2\%$ (external oscillator).

Note 9: The converter is in external SCK mode of operation such that the SCK pin is used as digital input. The frequency of the clock signal driving SCK during the data output is f_{ESCK} and is expressed in kHz.

Note 10: The converter is in internal SCK mode of operation such that the SCK pin is used as digital output. In this mode of operation the SCK pin has a total equivalent load capacitance $C_{\text{LOAD}} = 20\text{pF}$.

Note 11: The external oscillator is connected to the F_0 pin. The external oscillator frequency, f_{EOSC} , is expressed in kHz.

Note 12: The converter uses the internal oscillator.
 $F_0 = 0\text{V}$ or $F_0 = V_{\text{CC}}$.

Note 13: The output noise includes the contribution of the internal calibration operations.

Note 14: $V_{\text{REF}} = \text{FS}_{\text{SET}} - \text{ZS}_{\text{SET}}$. The minimum input voltage is limited to -0.3V and the maximum to $V_{\text{CC}} + 0.3\text{V}$.

Note 15: V_S is the voltage applied to a channel input. V_D is the voltage applied to the MUX output.

Note 16: $V_{\text{CC(DC)}} = 4.1\text{V}$, $V_{\text{CC(AC)}} = 2.8\text{V}_{\text{P-P}}$.

TYPICAL PERFORMANCE CHARACTERISTICS

Total Unadjusted Error (3V Supply)

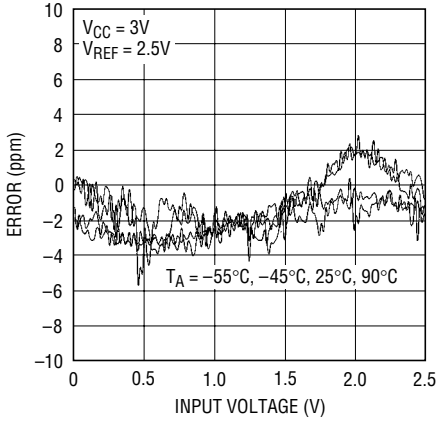

24248 G01

INL (3V Supply)

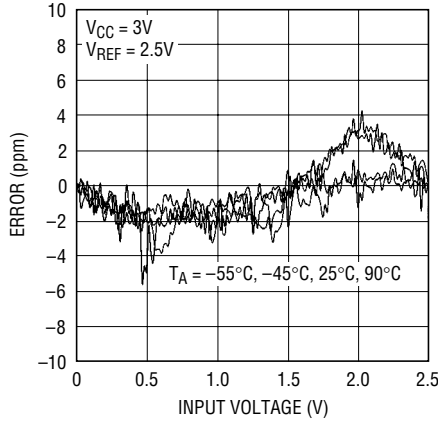

24248 G02

Negative Input Extended Total Unadjusted Error (3V Supply)

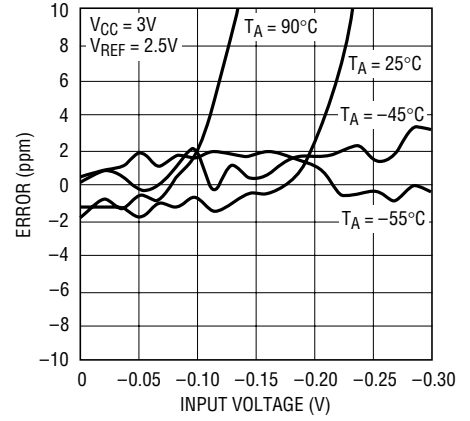

24248 G03

Positive Input Extended Total Unadjusted Error (3V Supply)

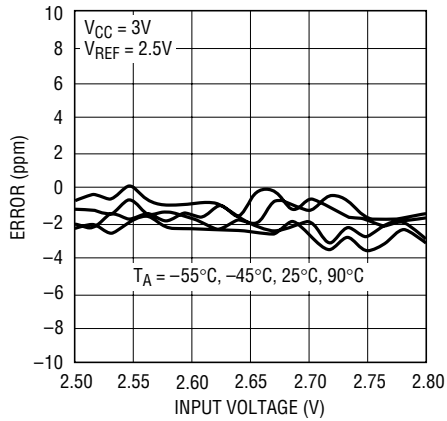

24248 G04

Total Unadjusted Error (5V Supply)

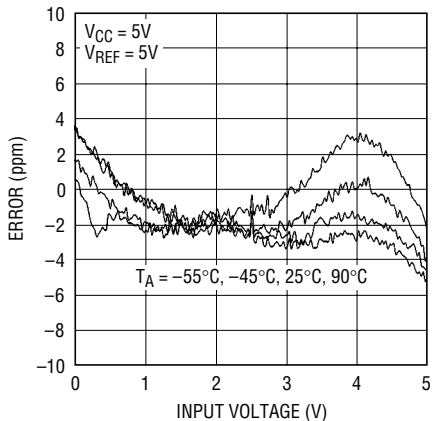

24248 G05

INL (5V Supply)

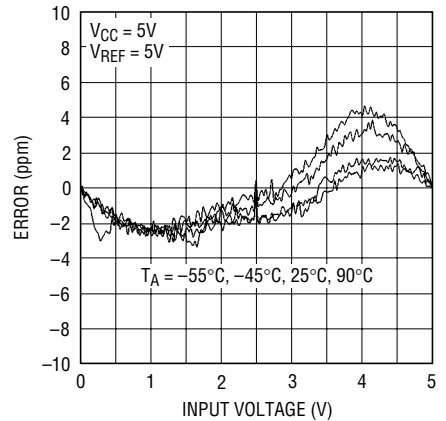

2420 G06

Negative Input Extended Total Unadjusted Error (5V Supply)

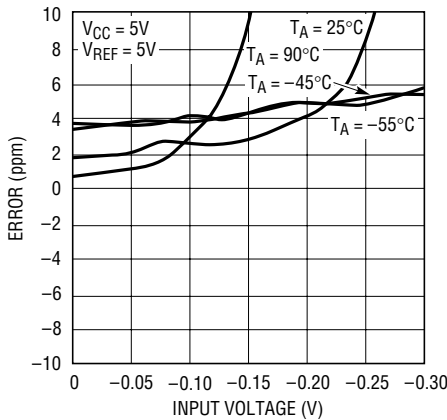

24248 G07

Positive Input Extended Total Unadjusted Error (5V Supply)

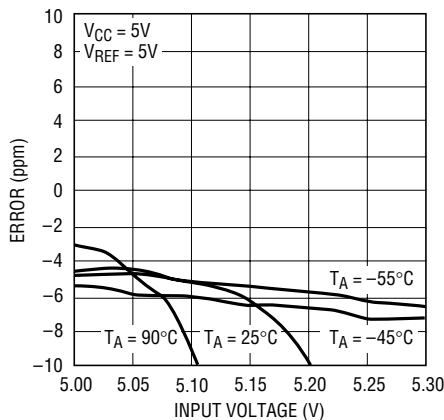

24248 G08

Offset Error vs Reference Voltage

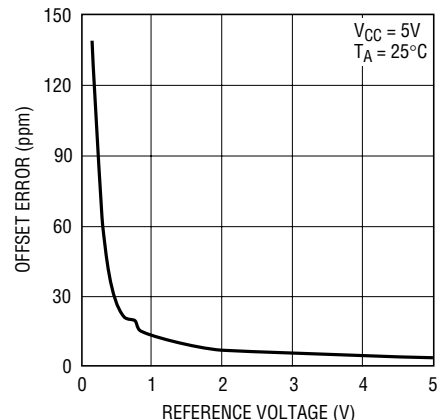

24248 G09

TYPICAL PERFORMANCE CHARACTERISTICS

RMS Noise vs Reference Voltage

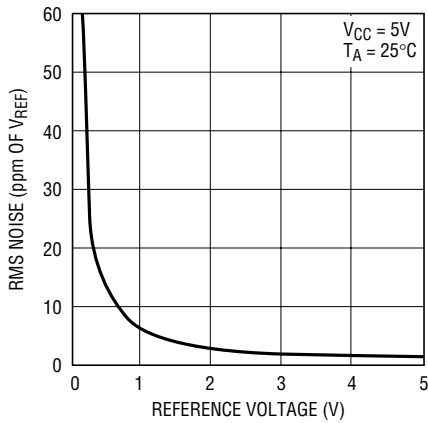

24248 G10

Offset Error vs V_{CC}

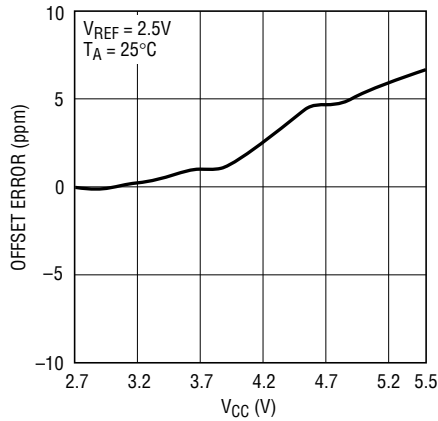

24248 G11

RMS Noise vs V_{CC}

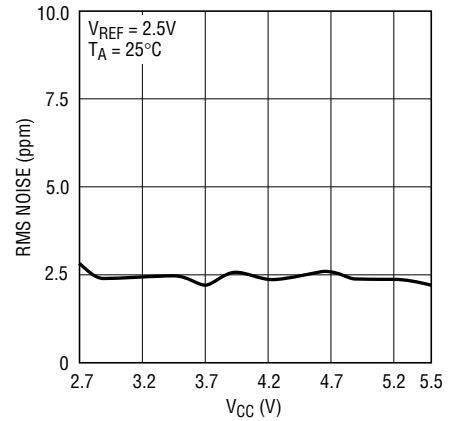

24248 G12

Noise Histogram

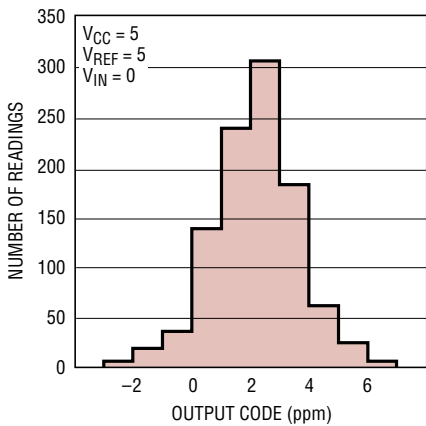

24248G13

RMS Noise vs Code Out

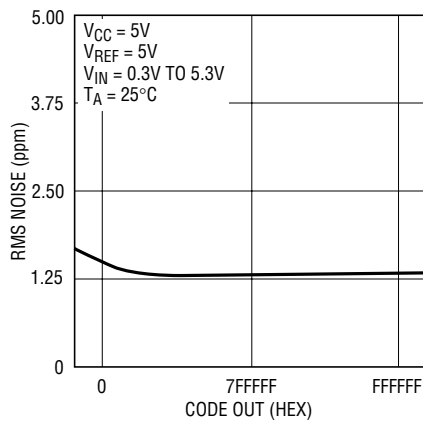

24248 G14

Offset Error vs Temperature

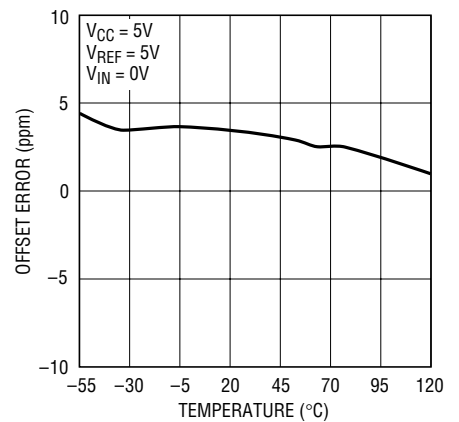

24248 G15

Full-Scale Error vs Temperature

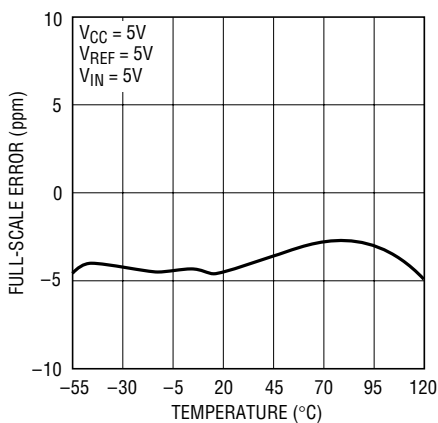

24248 G16

Full-Scale Error vs Reference Voltage

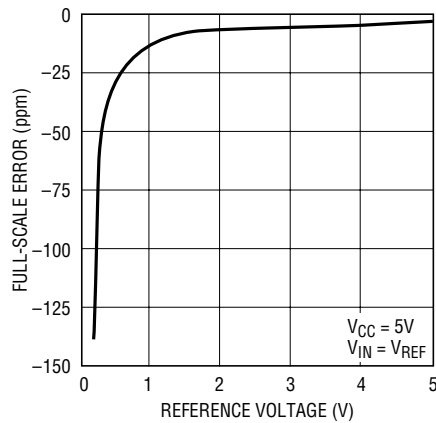

24248 G17

Full-Scale Error vs V_{CC}

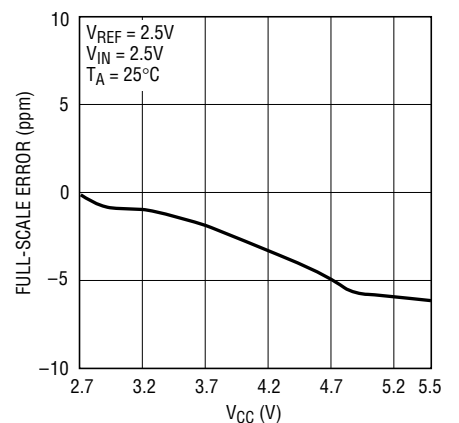

24248 G18

TYPICAL PERFORMANCE CHARACTERISTICS

Conversion Current vs Temperature

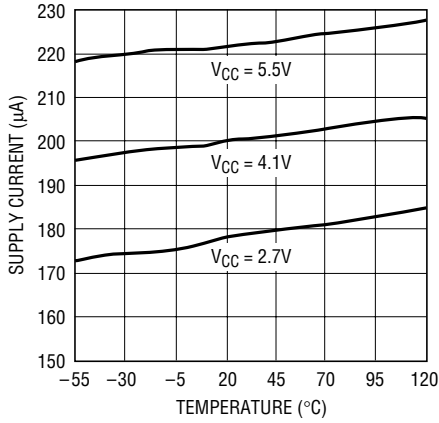

24248 G30

Sleep Current vs Temperature

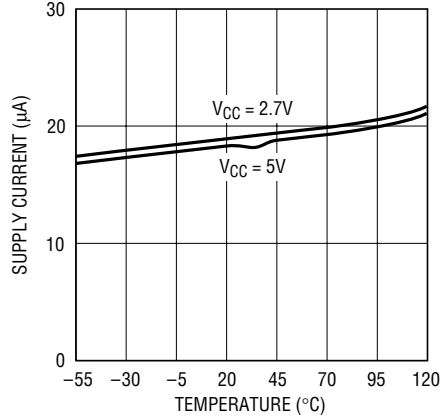

24248 G19

Rejection vs Frequency at VCC

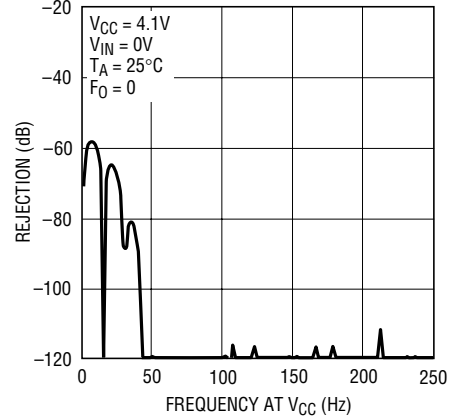

24248 G20

Rejection vs Frequency at VCC

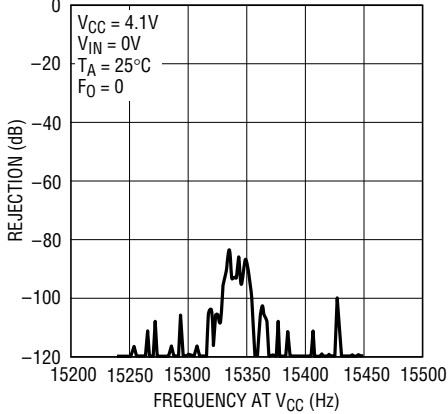

24248 G21

Rejection vs Frequency at VCC

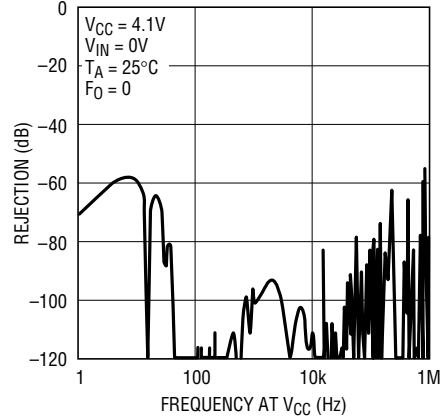

24248 G22

Rejection vs Frequency at VIN

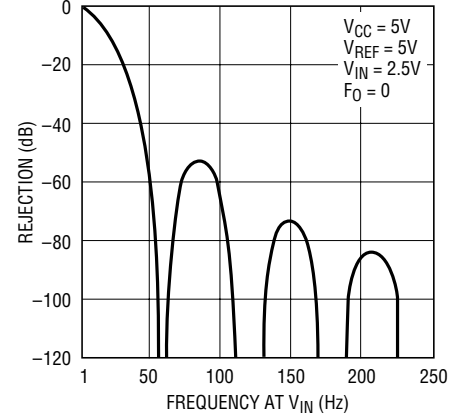

24248 G23

Rejection vs Frequency at VIN

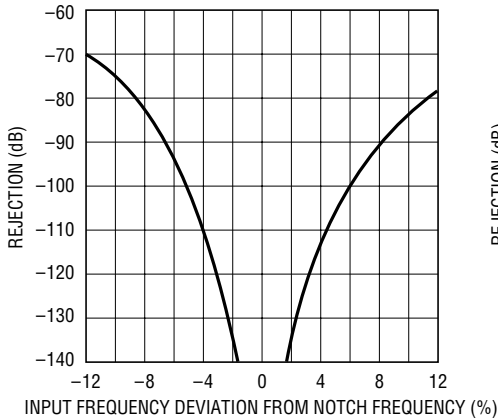

24248 G24

Rejection vs Frequency at VIN

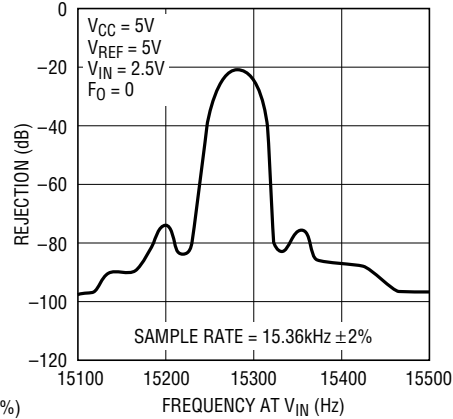

24248 G25

Rejection vs Frequency at VIN

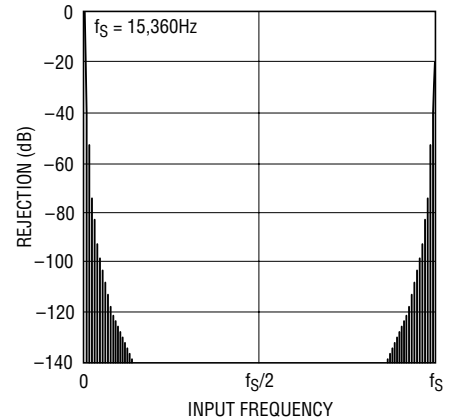

24248 F29

TYPICAL PERFORMANCE CHARACTERISTICS

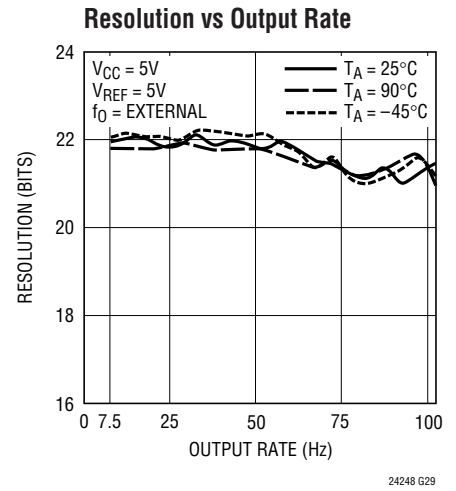
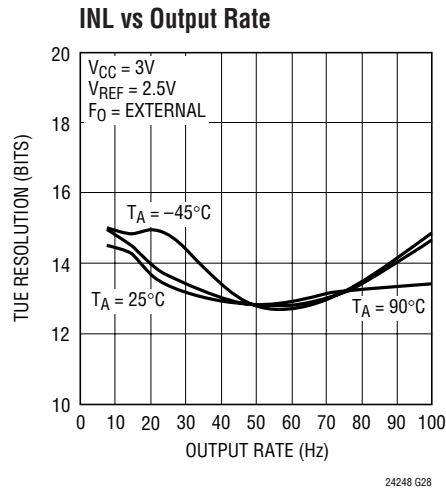
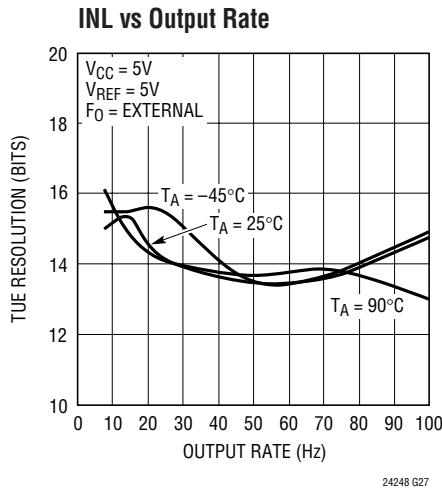

PIN FUNCTIONS

GND (Pins 1, 6, 16, 18, 22, 27, 28): Ground. Should be connected directly to a ground plane through a minimum length trace or it should be the single-point-ground in a single-point grounding system.

V_{CC} (Pins 2, 8): Positive Supply Voltage. $2.7V \leq V_{CC} \leq 5.5V$. Bypass to GND with a $10\mu F$ tantalum capacitor in parallel with $0.1\mu F$ ceramic capacitor as close to the part as possible.

FS_{SET} (Pin 3): Full-Scale Set Input. This pin defines the full-scale input value. When $V_{IN} = FS_{SET}$, the ADC outputs full scale ($FFFF_H$). The total reference voltage (V_{REF}) is $FS_{SET} - ZS_{SET}$.

ADCIN (Pin 4): Analog Input. The input voltage range is $-0.125 \cdot V_{REF}$ to $1.125 \cdot V_{REF}$. For $V_{REF} > 2.5V$ the input voltage range may be limited by the pin absolute maximum rating of $-0.3V$ to $V_{CC} + 0.3V$.

ZS_{SET} (Pin 5): Zero-Scale Set Input. This pin defines the zero-scale input value. When $V_{IN} = ZS_{SET}$, the ADC outputs zero scale (00000_H). For pin compatibility with the LTC2404/LTC2408 this pin must be grounded.

MUXOUT (Pin 7): MUX Output. This pin is the output of the multiplexer. Tie to ADCIN for normal operation.

CHO (Pin 9): Analog Multiplexer Input.

CH1 (Pin 10): Analog Multiplexer Input.

CH2 (Pin 11): Analog Multiplexer Input.

CH3 (Pin 12): Analog Multiplexer Input.

CH4 (Pin 13): Analog Multiplexer Input. No connect on the LTC2424.

CH5 (Pin 14): Analog Multiplexer Input. No connect on the LTC2424.

CH6 (Pin 15): Analog Multiplexer Input. No connect on the LTC2424.

CH7 (Pin 17): Analog Multiplexer Input. No connect on the LTC2424.

CLK (Pin 19): Shift Clock for Data In. This clock synchronizes the serial data transfer into the MUX. For normal operation, drive this pin in parallel with SCK.

\overline{CS}_{MUX} (Pin 20): MUX Chip Select Input. A logic high on this input allows the MUX to receive a channel address. A logic low enables the selected MUX channel and connects it to the MUXOUT pin for A/D conversion. For normal operation, drive this pin in parallel with \overline{CS}_{ADC} .

D_{IN} (Pin 21): Digital Data Input. The multiplexer address is shifted into this input on the last four rising CLK edges before \overline{CS}_{MUX} goes low.

PIN FUNCTIONS

CSADC (Pin 23): ADC Chip Select Input. A low on this pin enables the SDO digital output and following each conversion, the ADC automatically enters the Sleep mode and remains in a low power state as long as CSADC is high. If CSADC is low during the sleep state, the device draws normal power. A high on this pin also disables the SDO digital output. A low-to-high transition on CSADC during the Data Output state aborts the data transfer and starts a new conversion. For normal operation, drive this pin in parallel with CSMUX.

SDO (Pin 24): Three-State Digital Output. During the data output period this pin is used for serial data output. When the chip select CSADC is high ($CSADC = V_{CC}$), the SDO pin is in a high impedance state. During the Conversion and Sleep periods, this pin can be used as a conversion status output. The conversion status can be observed by pulling CSADC low.

SCK (Pin 25): Shift Clock for Data Out. This clock synchronizes the serial data transfer of the ADC data output. Data is shifted out of SDO on the falling edge of SCK. For normal operation, drive this pin in parallel with CLK.

F₀ (Pin 26): Digital input which controls the ADC's notch frequencies and conversion time. When the F₀ pin is connected to V_{CC} ($F_0 = V_{CC}$), the converter uses its internal oscillator and the digital filter first null is located at 50Hz. When the F₀ pin is connected to GND ($F_0 = 0V$), the converter uses its internal oscillator and the digital filter first null is located at 60Hz. When F₀ is driven by an external clock signal with a frequency f_{EOSC} , the converter uses this signal as its clock and the digital filter first null is located at a frequency $f_{EOSC}/2560$. The resulting output word rate is $f_{EOSC}/20510$.

FUNCTIONAL BLOCK DIAGRAM

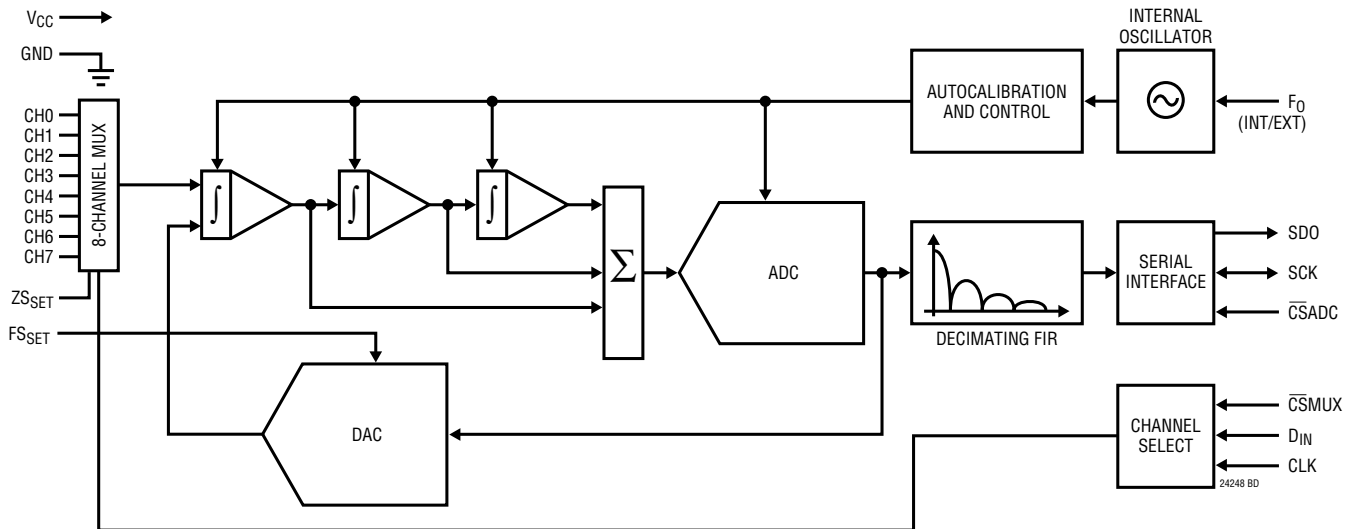

TEST CIRCUITS

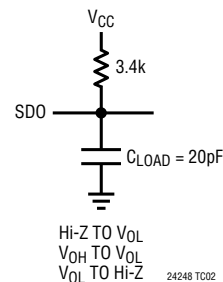
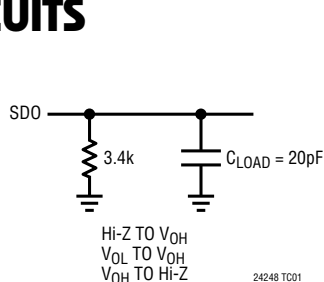

APPLICATIONS INFORMATION

Converter Operation Cycle

The LTC2424/LTC2428 are low power, 4-/8-channel delta-sigma analog-to-digital converters with easy-to-use 4-wire interfaces. Their operation is simple and made up of four states. The converter operation begins with the conversion, followed by a sleep state and concluded with the data output (see Figure 1). Channel selection may be performed while the device is in the sleep state or at the conclusion of the data output state. The interface consists of serial data output (SDO), serial clock (CLK/SCK), chip select ($\overline{\text{CSADC}}/\overline{\text{CSMUX}}$) and data input (D_{IN}). By tying SCK to CLK and $\overline{\text{CSADC}}$ to $\overline{\text{CSMUX}}$, the interface requires only four wires.

Initially, the LTC2424 or LTC2428 performs a conversion. Once the conversion is complete, the device enters the sleep state. While in the sleep state if $\overline{\text{CSADC}}$ is high, power consumption is reduced by an order of magnitude. The part remains in the sleep state as long as $\overline{\text{CSADC}}$ is logic HIGH. The conversion result is held indefinitely in a static shift register while the converter is in the sleep state.

Channel selection for the next conversion cycle is performed while the device is in the sleep state or at the end of the data output state. A specific channel is selected by applying a 4-bit serial word to the D_{IN} pin on the rising edge of CLK while $\overline{\text{CSMUX}}$ is HIGH, see Figure 4 and Table 3. The

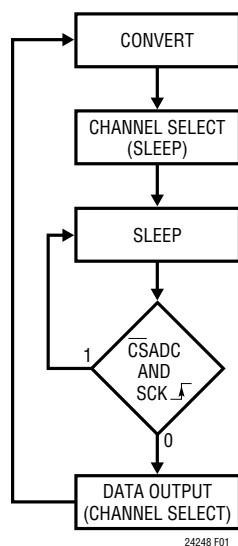

Figure 1. LTC2428 State Transition Diagram

channel is selected based on the last four bits clocked into the D_{IN} pin before $\overline{\text{CSMUX}}$ goes low. If D_{IN} is all 0's, the previous channel remains selected.

In the example, Figure 4, the MUX channel is selected during the sleep state, just before the data output state begins. Once the channel selection is complete, the device remains in the sleep state as long as $\overline{\text{CSADC}}$ remains HIGH.

Once $\overline{\text{CSADC}}$ is pulled low, the device begins outputting the conversion result. There is no latency in the conversion result. Since there is no latency, the first conversion following a change in input channel is valid and corresponds to that channel. The data output corresponds to the conversion just performed. This result is shifted out on the serial data output pin (SDO) under the control of the serial clock (SCK). Data is updated on the falling edge of SCK allowing the user to reliably latch data on the rising edge of SCK, see Figure 4. The data output state is concluded once 24 bits are read out of the ADC or when $\overline{\text{CSADC}}$ is brought HIGH. The device automatically initiates a new conversion and the cycle repeats.

Through timing control of the $\overline{\text{CSADC}}$ and SCK pins, the LTC2424/LTC2428 offer two modes of operation: internal or external SCK. These modes do not require programming configuration registers; moreover, they do not disturb the cyclic operation described above. These modes of operation are described in detail in the Serial Interface Timing Modes section.

Conversion Clock

A major advantage delta-sigma converters offer over conventional type converters is an on-chip digital filter (commonly known as Sinc or Comb filter). For high resolution, low frequency applications, this filter is typically designed to reject line frequencies of 50 or 60Hz plus their harmonics. In order to reject these frequencies in excess of 110dB, a highly accurate conversion clock is required. The LTC2424/LTC2428 incorporate an on-chip highly accurate oscillator. This eliminates the need for external frequency setting components such as crystals or oscillators. Clocked by the on-chip oscillator, the LTC2424/LTC2428 reject line frequencies (50 or 60Hz $\pm 2\%$) a minimum of 110dB.

APPLICATIONS INFORMATION

Ease of Use

The LTC2424/LTC2428 data output has no latency, filter settling or redundant data associated with the conversion cycle. There is a one-to-one correspondence between the conversion and the output data. Therefore, multiplexing an analog input voltage is easy.

The LTC2424/LTC2428 perform offset and full-scale calibrations every conversion cycle. This calibration is transparent to the user and has no effect on the cyclic operation described above. The advantage of continuous calibration is extreme stability of offset and full-scale readings with respect to time, supply voltage change and temperature drift.

Power-Up Sequence

The LTC2424/LTC2428 automatically enter an internal reset state when the power supply voltage V_{CC} drops below approximately 2.2V. When the V_{CC} voltage rises above this critical threshold, the converter creates an internal power-on-reset (POR) signal with duration of approximately 0.5ms. The POR signal clears all internal registers within the ADC and initiates a conversion. At power-up, the multiplexer channel is disabled and should be programmed once the device enters the sleep state. The results of the first conversion following a POR are not valid since a multiplexer channel was disabled.

Reference Voltage Range

The LTC2424/LTC2428 can accept a reference voltage ($V_{REF} = FS_{SET} - ZS_{SET}$) from 0V to V_{CC} . The converter output noise is determined by the thermal noise of the front-end circuits, and as such, its value in microvolts is nearly constant with reference voltage. A decrease in reference voltage will not significantly improve the converter's effective resolution. On the other hand, a reduced reference voltage will improve the overall converter INL performance. The recommended range for the LTC2424/LTC2428 voltage reference is 100mV to V_{CC} .

Input Voltage Range

The converter is able to accommodate system level offset and gain errors as well as system level overrange situations due to its extended input range, see Figure 2.

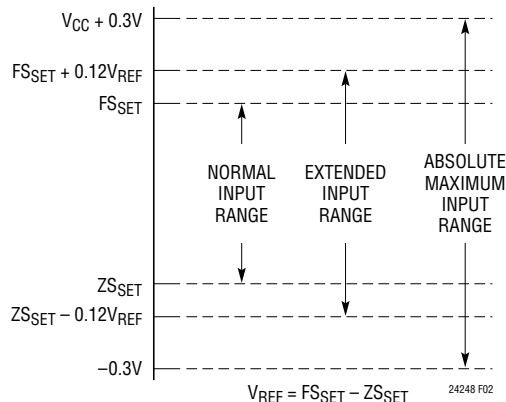

Figure 2. LTC2424/LTC2428 Input Range

The LTC2424/LTC2428 converts input signals within the extended input range of $-0.125 \cdot V_{REF}$ to $1.125 \cdot V_{REF}$ ($V_{REF} = FS_{SET} - ZS_{SET}$).

For large values of V_{REF} this range is limited to a voltage range of $-0.3V$ to $(V_{CC} + 0.3V)$. Beyond this range the input ESD protection devices begin to turn on and the errors due to the input leakage current increase rapidly.

Input signals applied to V_{IN} may extend below ground by $-300mV$ and above V_{CC} by $300mV$. In order to limit any fault current, a resistor of up to 5k may be added in series with any channel input pin (CH0 to CH7) without affecting the performance of the device. In the physical layout, it is important to maintain the parasitic capacitance of the connection between this series resistance and the channel input pin as low as possible; therefore, the resistor should be located as close as practical to the channel input pin. The effect of the series resistance on the converter accuracy can be evaluated from the curves presented in the Analog Input/Reference Current section. In addition, a series resistor will introduce a temperature dependent offset error due to the input leakage current. A 1nA input leakage current will develop a 1ppm offset error on a 5k resistor if $V_{REF} = 5V$. This error has a very strong temperature dependency.

Output Data Format

The LTC2424/LTC2428 serial output data stream is 24 bits long. The first 4 bits represent status information indicating the sign, input range and conversion state. The next 20 bits are the conversion result, MSB first.

APPLICATIONS INFORMATION

The LTC2424/LTC2428 can be interchanged with the LTC2404/LTC2408. The two devices are designed to allow the user to incorporate either device in the same design as long as ZS_{SET} (Pin 5) of the LTC2424/LTC2428 is tied to ground. While the LTC2424/LTC2428 output word lengths are 24 bits (as opposed to the 32-bit output of the LTC2404/LTC2408), their output clock timing can be identical to the LTC2404/LTC2408. As shown in Figure 3, the LTC2424/LTC2428 data output is concluded on the falling edge of the 24th serial clock (SCK). In order to maintain drop-in compatibility with the LTC2404/LTC2408, it is possible to clock the LTC2424/LTC2428 with an additional 8 serial clock pulses. This results in 8 additional output bits which are logic HIGH.

Bit 23 (first output bit) is the end of conversion (\overline{EOC}) indicator. This bit is available at the SDO pin during the conversion and sleep states whenever the \overline{CS} pin is LOW. This bit is HIGH during the conversion and goes LOW when the conversion is complete.

Bit 22 (second output bit) is a dummy bit (DMY) and is always LOW.

Bit 21 (third output bit) is the conversion result sign indicator (SIG). If V_{IN} is >0 , this bit is HIGH. If V_{IN} is <0 , this bit is LOW. The sign bit changes state during the zero code.

Bit 20 (forth output bit) is the extended input range (EXR) indicator. If the input is within the normal input range $0 \leq V_{IN} \leq V_{REF}$, this bit is LOW. If the input is outside the normal input range, $V_{IN} > V_{REF}$ or $V_{IN} < 0$, this bit is HIGH.

The function of these bits is summarized in Table 1.

Table 1. LTC2424/LTC2428 Status Bits

Input Range	Bit 23 EOC	Bit 22 DMY	Bit 21 SIG	Bit 20 EXR
$V_{IN} > V_{REF}$	0	0	1	1
$0 < V_{IN} \leq V_{REF}$	0	0	1	0
$V_{IN} = 0^+/0^-$	0	0	1/0	0
$V_{IN} < 0$	0	0	0	1

Bit 19 (fifth output bit) is the most significant bit (MSB).

Bits 19-0 are the 20-bit conversion result MSB first.

Bit 0 is the least significant bit (LSB).

Data is shifted out of the SDO pin under control of the serial clock (SCK), see Figure 4. Whenever \overline{CS}_{ADC} is HIGH, SDO remains high impedance and any SCK clock pulses are ignored by the internal data out shift register.

In order to shift the conversion result out of the device, \overline{CS}_{ADC} must first be driven LOW. \overline{EOC} is seen at the SDO pin of the device once \overline{CS}_{ADC} is pulled LOW. \overline{EOC} changes real time from HIGH to LOW at the completion of a conversion. This signal may be used as an interrupt for an external microcontroller. Bit 23 (\overline{EOC}) can be captured on the first rising edge of SCK. Bit 22 is shifted out of the device on the first falling edge of SCK. The final data bit (Bit 0) is shifted out on the falling edge of the 23rd SCK and may be latched on the rising edge of the 24th SCK pulse. On the falling edge of the 24th SCK pulse, SDO goes HIGH indicating a new conversion cycle has been initiated. This bit serves as \overline{EOC} (Bit 23) for the next conversion cycle. Table 2 summarizes the output data format.

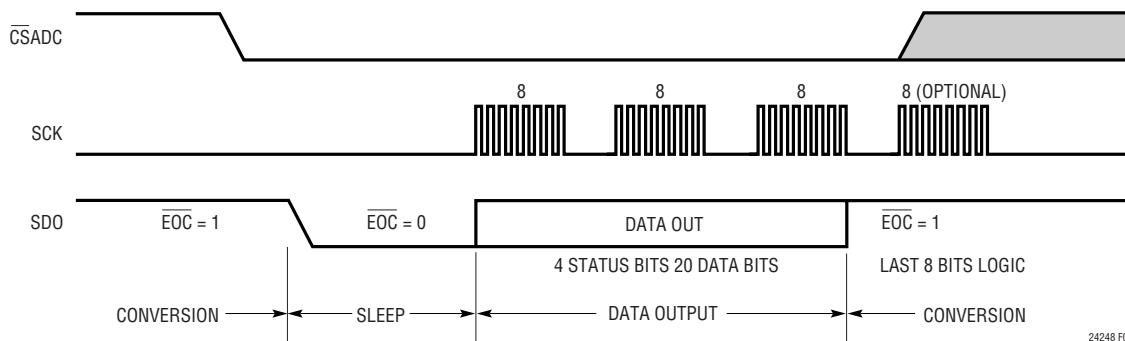

Figure 3. LTC2424/LTC2428 Compatible Timing with the LTC2404/LTC2408

APPLICATIONS INFORMATION

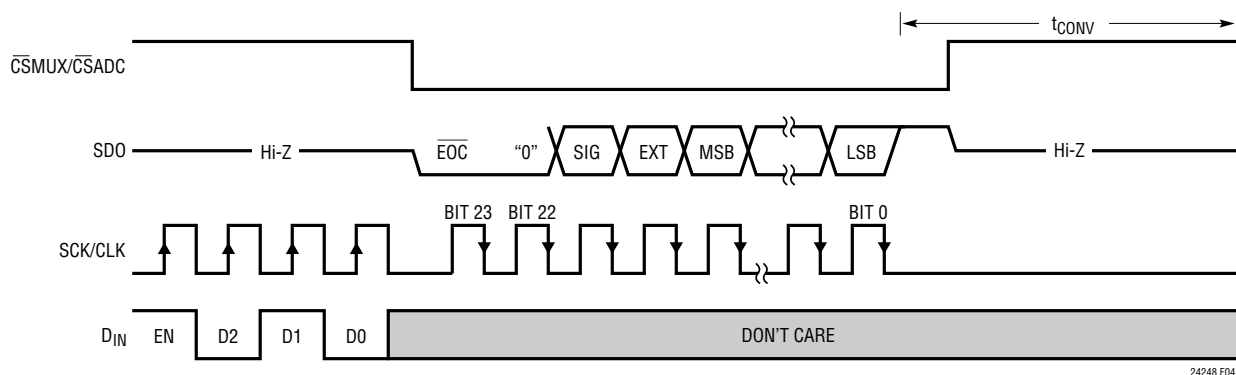

Figure 4. Typical Data Input/Output Timing

Table 2. LTC2424/LTC2428 Output Data Format

Input Voltage	Bit 23 EOC	Bit 22 DMY	Bit 21 SIG	Bit 20 EXR	Bit 19 MSB	Bit 18	Bit 17	Bit 16	Bit 15	...	Bit 0 LSB
$V_{IN} > 9/8 \cdot V_{REF}$	0	0	1	1	0	0	0	1	1	...	1
$9/8 \cdot V_{REF}$	0	0	1	1	0	0	0	1	1	...	1
$V_{REF} + 1\text{LSB}$	0	0	1	1	0	0	0	0	0	...	0
V_{REF}	0	0	1	0	1	1	1	1	1	...	1
$3/4V_{REF} + 1\text{LSB}$	0	0	1	0	1	1	0	0	0	...	0
$3/4V_{REF}$	0	0	1	0	1	0	1	1	1	...	1
$1/2V_{REF} + 1\text{LSB}$	0	0	1	0	1	0	0	0	0	...	0
$1/2V_{REF}$	0	0	1	0	0	1	1	1	1	...	1
$1/4V_{REF} + 1\text{LSB}$	0	0	1	0	0	1	0	0	0	...	0
$1/4V_{REF}$	0	0	1	0	0	0	1	1	1	...	1
$0^+/0^-$	0	0	1/0*	0	0	0	0	0	0	...	0
-1LSB	0	0	0	1	1	1	1	1	1	...	1
$-1/8 \cdot V_{REF}$	0	0	0	1	1	1	1	0	0	...	0
$V_{IN} < -1/8 \cdot V_{REF}$	0	0	0	1	1	1	1	0	0	...	0

*The sign bit changes state during the 0 code.

As long as the voltage on the V_{IN} pin is maintained within the -0.3V to $(V_{CC} + 0.3\text{V})$ absolute maximum operating range, a conversion result is generated for any input value from $-0.125 \cdot V_{REF}$ to $1.125 \cdot V_{REF}$. For input voltages greater than $1.125 \cdot V_{REF}$, the conversion result is clamped to the value corresponding to $1.125 \cdot V_{REF}$. For input voltages below $-0.125 \cdot V_{REF}$, the conversion result is clamped to the value corresponding to $-0.125 \cdot V_{REF}$.

Channel Selection

Typically, $\overline{\text{CSADC}}$ and $\overline{\text{CSMUX}}$ are tied together or $\overline{\text{CSADC}}$ is inverted and drives $\overline{\text{CSMUX}}$. SCK and CLK are tied together and driven with a common clock signal. During channel selection, $\overline{\text{CSMUX}}$ is HIGH. Data is shifted into the D_{IN} pin on the rising edge of CLK, see Figure 4. Table 3 shows the bit combinations for channel selection. In order to enable the multiplexer output, $\overline{\text{CSMUX}}$ must be pulled

APPLICATIONS INFORMATION

LOW. The multiplexer should be programmed after the previous conversion is complete. In order to guarantee the conversion is complete, the multiplexer addressing should be delayed a minimum t_{CONV} (approximately 133ms for a 60Hz notch) after the data out is read.

While the multiplexer is being programmed, the ADC is in the sleep state. Once the MUX addressing is complete, the data from the preceding conversion can be read. A new conversion cycle is initiated following the data read cycle with the analog input tied to the newly selected channel.

Table 3. Logic Table for Channel Selection

CHANNEL STATUS	EN	D2	D1	D0
All Off	0	X	X	X
CH0	1	0	0	0
CH1	1	0	0	1
CH2	1	0	1	0
CH3	1	0	1	1
CH4*	1	1	0	0
CH5*	1	1	0	1
CH6*	1	1	1	0
CH7*	1	1	1	1

*Not used for the LTC2424.

Frequency Rejection Selection (F_0 Pin Connection)

The LTC2424/LTC2428 internal oscillator provides better than 110dB normal mode rejection at the line frequency and all its harmonics for 50Hz $\pm 2\%$ or 60Hz $\pm 2\%$. For 60Hz rejection, F_0 (Pin 26) should be connected to GND (Pin 1) while for 50Hz rejection the F_0 pin should be connected to V_{CC} (Pin 2).

The selection of 50Hz or 60Hz rejection can also be made by driving F_0 to an appropriate logic level. A selection change during the sleep or data output states will not disturb the converter operation. If the selection is made during the conversion state, the result of the conversion in progress may be outside specifications but the following conversions will not be affected.

When a fundamental rejection frequency different from 50Hz or 60Hz is required or when the converter must be synchronized with an outside source, the LTC2424/LTC2428 can operate with an external conversion clock.

The converter automatically detects the presence of an external clock signal at the F_0 pin and turns off the internal oscillator. The frequency f_{EOSC} of the external signal must be at least 2560Hz (1Hz notch frequency) to be detected. The external clock signal duty cycle is not significant as long as the minimum and maximum specifications for the high and low periods t_{HEO} and t_{LEO} are observed.

While operating with an external conversion clock of a frequency f_{EOSC} , the LTC2424/LTC2428 provide better than 110dB normal mode rejection in a frequency range $f_{EOSC}/2560 \pm 4\%$ and its harmonics. The normal mode rejection as a function of the input frequency deviation from $f_{EOSC}/2560$ is shown in Figure 5.

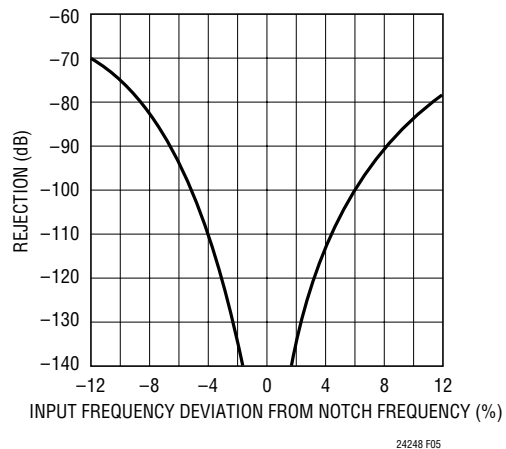

Figure 5. LTC2424/LTC2428 Normal Mode Rejection When Using an External Oscillator of Frequency f_{EOSC}

Whenever an external clock is not present at the F_0 pin the converter automatically activates its internal oscillator and enters the Internal Conversion Clock mode. The LTC2424/LTC2428 operation will not be disturbed if the change of conversion clock source occurs during the sleep state or during the data output state while the converter uses an external serial clock. If the change occurs during the conversion state, the result of the conversion in progress may be outside specifications but the following conversions will not be affected. If the change occurs during the data output state and the converter is in the Internal SCK mode, the serial clock duty cycle may be affected but the serial data stream will remain valid.

APPLICATIONS INFORMATION

Table 4 summarizes the duration of each state as a function of F_0 .

Operation at Higher Data Output Rates

The LTC2424/LTC2428 typically operate with an internal oscillator of 153.6kHz. This corresponds to a notch frequency of 60Hz and an output rate of 7.5 samples/second. The internal oscillator is enabled if the F_0 pin is logic LOW (logic HIGH for a 50Hz notch). It is possible to drive the F_0 pin with an external oscillator for higher data output rates.

As shown in Figure 6, an external clock of 2.051MHz applied to the F_0 pin results in a notch frequency of 800Hz with a data output rate of 100 samples/second.

Figure 7 shows the total unadjusted error (Offset Error + Full-Scale Error + INL + DNL) as a function of the output data rate with a 5V reference. The relationship between the output data rate (ODR) and the frequency applied to the F_0 pin (F_0) is:

$$ODR = F_0/20510$$

Table 4. LTC2424/LTC2428 State Duration

State	Operating Mode		Duration
CONVERT	Internal Oscillator	$F_0 = \text{LOW}$ (60Hz Rejection)	133ms
		$F_0 = \text{HIGH}$ (50Hz Rejection)	160ms
	External Oscillator	$F_0 = \text{External Oscillator}$ with Frequency f_{EOSC} kHz ($f_{EOSC}/2560$ Rejection)	$20510/f_{EOSC}$ (In Seconds)
SLEEP			As Long As $\overline{\text{CSADC}} = \text{HIGH}$ Until $\overline{\text{CSADC}} = 0$ and $\text{SCK} \downarrow$
DATA OUTPUT	Internal Serial Clock	$F_0 = \text{LOW/HIGH}$ (Internal Oscillator)	As Long As $\overline{\text{CSADC}} = \text{LOW}$ But Not Longer Than 1.67ms (32 SCK cycles)
		$F_0 = \text{External Oscillator}$ with Frequency f_{EOSC} kHz	As Long As $\overline{\text{CSADC}} = \text{LOW}$ But Not Longer Than $256/f_{EOSC}$ ms (32 SCK cycles)
	External Serial Clock with Frequency f_{SCK} kHz	As Long As $\overline{\text{CSADC}} = \text{LOW}$ But Not Longer Than $32/f_{SCK}$ ms (32 SCK cycles)	
MAXIMUM OUTPUT WORD RATE (OWR)			$OWR = \frac{1}{t_{\text{CONVERT}} + t_{\text{DATAOUTPUT}}}$ in Hz

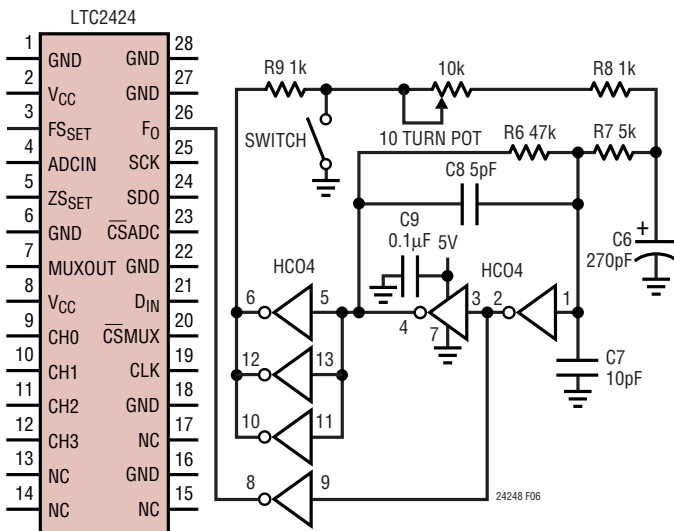

Figure 6. Selectable 100 Sample/Second Turbo Mode

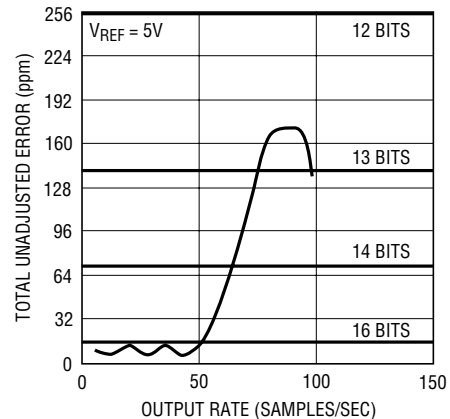

Figure 7. Total Error vs Output Rate ($V_{REF} = 5V$)

APPLICATIONS INFORMATION

For output data rates up to 50 samples/second, the total unadjusted error (TUE) is better than 16 bits, and better than 12 bits at 100 samples/second. As shown in Figure 8, for output data rates of 100 samples/second, the TUE is better than 15 bits for V_{REF} below 2.5V. Figure 9 shows an unaveraged total unadjusted error for the LTC2424 or LTC2428 operating at 100 samples/second with $V_{REF} = 2.5V$. Figure 10 shows the same device operating with a 5V reference and an output data rate of 7.5 samples/second.

At 100 samples/second, the LTC2424/LTC2428 can be used to capture transient data. This is useful for monitoring settling or auto gain ranging in a system. The LTC2424/LTC2428 can monitor signals at an output rate of 100 samples/second. After acquiring 100 samples/second data, the F_0 pin may be driven LOW enabling 60Hz rejection to 110dB and the highest possible DC accuracy. The no latency architecture of the LTC2424/LTC2428 allows consecutive readings (one at 100 samples/second the next at 7.5 samples/second) without interaction between the two readings.

As shown in Figure 11, the LTC2424/LTC2428 can capture transient data with 90dB of dynamic range (with a 300mV_{P-P} input signal at 2Hz). The exceptional DC performance of the LTC2424/LTC2428 enables signals to be digitized independent of a large DC offset. Figures 12a and 12b show the dynamic performance with a 15Hz signal superimposed on a 2V DC level. The same signal with no DC level is shown in Figures 12c and 12d.

SERIAL INTERFACE

The LTC2424/LTC2428 transmit the conversion results, program the channel selection, and receive the start of conversion command through a synchronous 4-wire interface (SCK = CLK, CSADC = CSMUX). During the conversion and sleep states, this interface can be used to assess the converter status. While in the sleep state this interface may be used to program an input channel. During the data output state, it is used to read the conversion result.

ADC Serial Clock Input/Output (SCK)

The serial clock signal present on SCK (Pin 25) is used to synchronize the data transfer. Each bit of data is shifted out of the SDO pin on the falling edge of the serial clock.

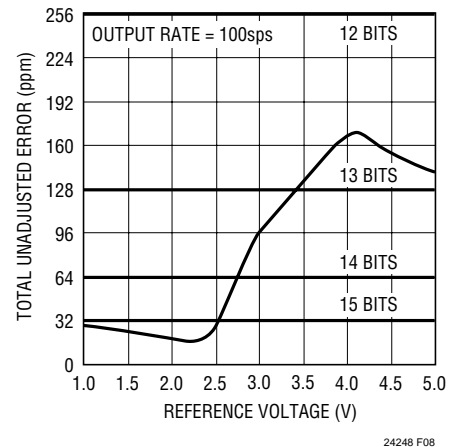

Figure 8. Total Error vs V_{REF} (Output Rate = 100sps)

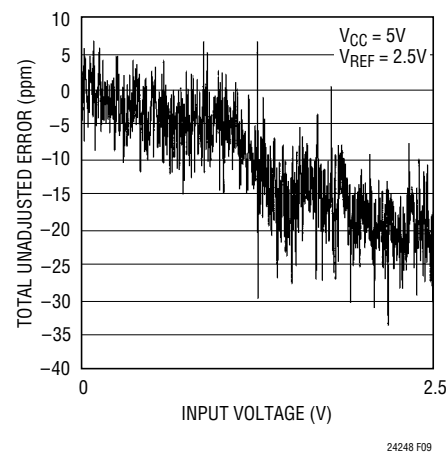

Figure 9. Total Unadjusted Error at 100 Samples/Second (No Averaging)

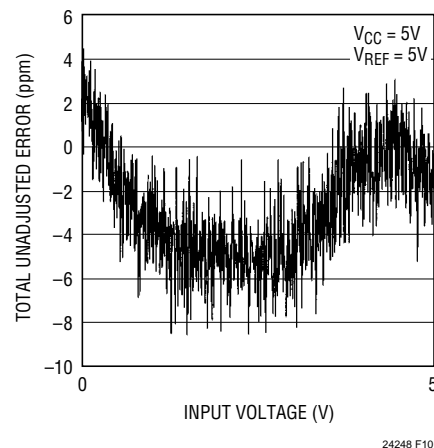

Figure 10. Total Unadjusted Error at 7.5 Samples/Second (No Averaging)

APPLICATIONS INFORMATION

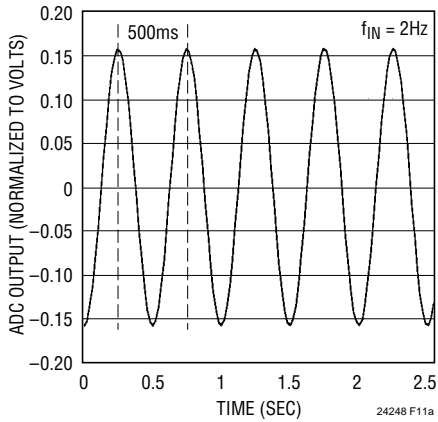

Figure 11a. Digitized Waveform

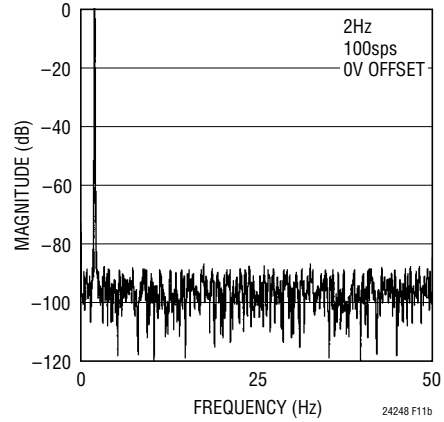

Figure 11b. Output FFT

Figure 11. Transient Signal Acquisition

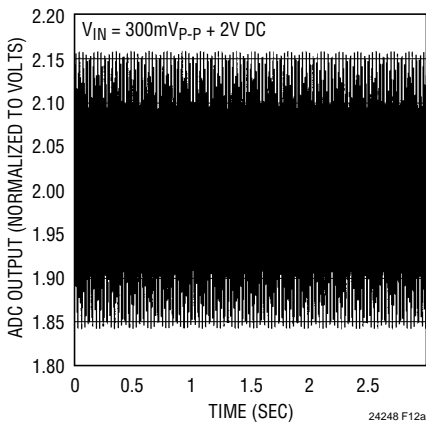

Figure 12a. Digitized Waveform with 2V DC Offset

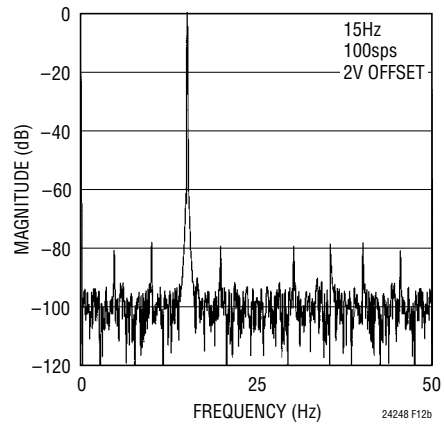

Figure 12b. FFT Waveform with 2V DC Offset

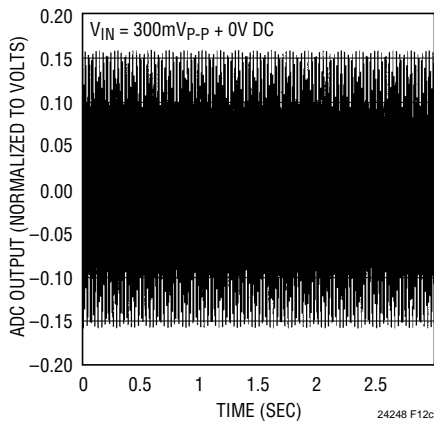

Figure 12c. Digitized Waveform with No Offset

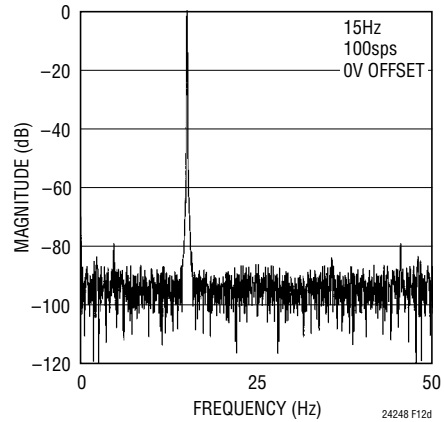

Figure 12d. FFT Waveform with No Offset

Figure 12. Using the LTC2424/LTC2428's High Accuracy Wide Dynamic Range to Digitize a 300mV_{p-p} 15Hz Waveform with a Large DC Offset ($V_{CC} = 5V$, $V_{REF} = 5V$)

APPLICATIONS INFORMATION

In the Internal SCK mode of operation, the SCK pin is an output and the LTC2424/LTC2428 creates its own serial clock by dividing the internal conversion clock by 8. In the External SCK mode of operation, the SCK pin is used as input. The internal or external SCK mode is selected on power-up and then reselected every time a HIGH-to-LOW transition is detected at the CSADC pin. If SCK is HIGH or floating at power-up or during this transition, the converter enters the internal SCK mode. If SCK is LOW at power-up or during this transition, the converter enters the external SCK mode.

Multiplexer Serial Input Clock (CLK)

Generally, this pin is externally tied to SCK for 4-wire operation. On the rising edge of CLK (Pin 19) with $\overline{\text{CSMUX}}$ held HIGH, data is serially shifted into the multiplexer. If $\overline{\text{CSMUX}}$ is LOW the CLK input will be disabled and the channel selection unchanged.

Serial Data Output (SDO)

The serial data output pin, SDO (Pin 24), drives the serial data during the data output state. In addition, the SDO pin is used as an end of conversion indicator during the conversion and sleep states.

When $\overline{\text{CSADC}}$ (Pin 23) is HIGH, the SDO driver is switched to a high impedance state. This allows sharing the serial interface with other devices. If $\overline{\text{CSADC}}$ is LOW during the convert or sleep state, SDO will output $\overline{\text{EOC}}$. If $\overline{\text{CSADC}}$ is LOW during the conversion phase, the $\overline{\text{EOC}}$ bit appears HIGH on the SDO pin. Once the conversion is complete, $\overline{\text{EOC}}$ goes LOW. The device remains in the sleep state until the first rising edge of SCK occurs while $\overline{\text{CSADC}} = 0$.

ADC Chip Select Input ($\overline{\text{CSADC}}$)

The active LOW chip select, $\overline{\text{CSADC}}$ (Pin 23), is used to test the conversion status and to enable the data output transfer as described in the previous sections.

In addition, the $\overline{\text{CSADC}}$ signal can be used to trigger a new conversion cycle before the entire serial data transfer has been completed. The LTC2424/LTC2428 will abort any serial data transfer in progress and start a new conversion cycle anytime a LOW-to-HIGH transition is detected at the $\overline{\text{CSADC}}$ pin after the converter has entered the data output state (i.e., after the first rising edge of SCK occurs with $\overline{\text{CSADC}} = 0$).

Multiplexer Chip Select ($\overline{\text{CSMUX}}$)

For 4-wire operation, this pin is tied directly to $\overline{\text{CSADC}}$ or the output of an inverter tied to $\overline{\text{CSADC}}$. $\overline{\text{CSMUX}}$ (Pin 20) is driven HIGH during selection of a multiplexer channel. On the falling edge of $\overline{\text{CSMUX}}$, the selected channel is enabled and drives MUXOUT.

Data Input (D_{IN})

The data input to the multiplexer, D_{IN} (Pin 21), is used to program the multiplexer. The input channel is selected by serially shifting a 4-bit input word into the D_{IN} pin under the control of the multiplexer clock, CLK. Data is shifted into the multiplexer on the rising edge of CLK. Table 3 shows the logic table for channel selection. In order to select or change a previously programmed channel, an enable bit ($D_{\text{IN}} = 1$) must proceed the 3-bit channel select serial data. The user may set $D_{\text{IN}} = 0$ to continually convert on the previously selected channel.

SERIAL INTERFACE TIMING MODES

The LTC2424/LTC2428's 4-wire interface is SPI and MICROWIRE compatible. This interface offers two modes of operation. These include an internal or external serial clock. The following sections describe both of these serial interface timing modes in detail. For both cases the converter can use the internal oscillator ($F_0 = \text{LOW}$ or $F_0 = \text{HIGH}$) or an external oscillator connected to the F_0 pin. Refer to Table 5 for a summary.

Table 5. LTC2424/LTC2428 Interface Timing Modes

Configuration	SCK Source	Conversion Cycle Control	Data Output Control	Connection and Waveforms
External SCK	External	$\overline{\text{CSADC}}$ and SCK	$\overline{\text{CSADC}}$ and SCK	Figures 13, 14, 15
Internal SCK	Internal	$\overline{\text{CSADC}} \downarrow$	$\overline{\text{CSADC}} \downarrow$	Figures 16, 17

APPLICATIONS INFORMATION

External Serial Clock (SPI/MICROWIRE Compatible)

This timing mode uses an external serial clock (SCK) to shift out the conversion result, see Figure 13. This same external clock signal drives the CLK pin in order to program the multiplexer. A single CS signal drives both the multiplexer CSMUX and converter CSADC inputs. This common signal is used to monitor and control the state of the conversion as well as enable the channel selection.

The serial clock mode is selected on the falling edge of CSADC. To select the external serial clock mode, the serial clock pin (SCK) must be LOW during each CSADC falling edge.

The serial data output pin (SDO) is Hi-Z as long as CSADC is HIGH. At any time during the conversion cycle, CSADC may be pulled LOW in order to monitor the state of the converter. While CSADC is LOW, EOC is output to the SDO pin. EOC = 1 while a conversion is in progress and EOC = 0 if the device is in the sleep state. Independent of CSADC, the device automatically enters the sleep state once the conversion is complete. While the device is in the sleep state and CSADC is HIGH, the power consumption is reduced an order of magnitude.

While the device is in the sleep state, prior to entering the data output state, the user may program the multiplexer. As shown in Figure 13, the multiplexer channel is selected by serial shifting a 4-bit word into the DIN pin on the rising edge of CLK (CLK is tied to SCK). The first bit is an enable bit that must be HIGH in order to program a channel. The next three bits determine which channel is selected, see Table 3. On the falling edge of CSMUX, the new channel is selected and will be valid for the first conversion performed following the data output state. Clock signals applied to the CLK pin while CSMUX is LOW (during the data output state) will have no effect on the channel selection. Furthermore, if DIN is held LOW or CLK is held LOW during the sleep state, the channel selection is unchanged.

When the device is in the sleep state (EOC = 0), its conversion result is held in an internal static shift register. The device remains in the sleep state until the first rising edge of SCK is seen while CSADC is LOW. Data is shifted out the SDO pin on each falling edge of SCK. This enables external circuitry to latch the output on the rising edge of SCK. EOC can be latched on the first rising edge of SCK and the last bit of the conversion result can be latched on

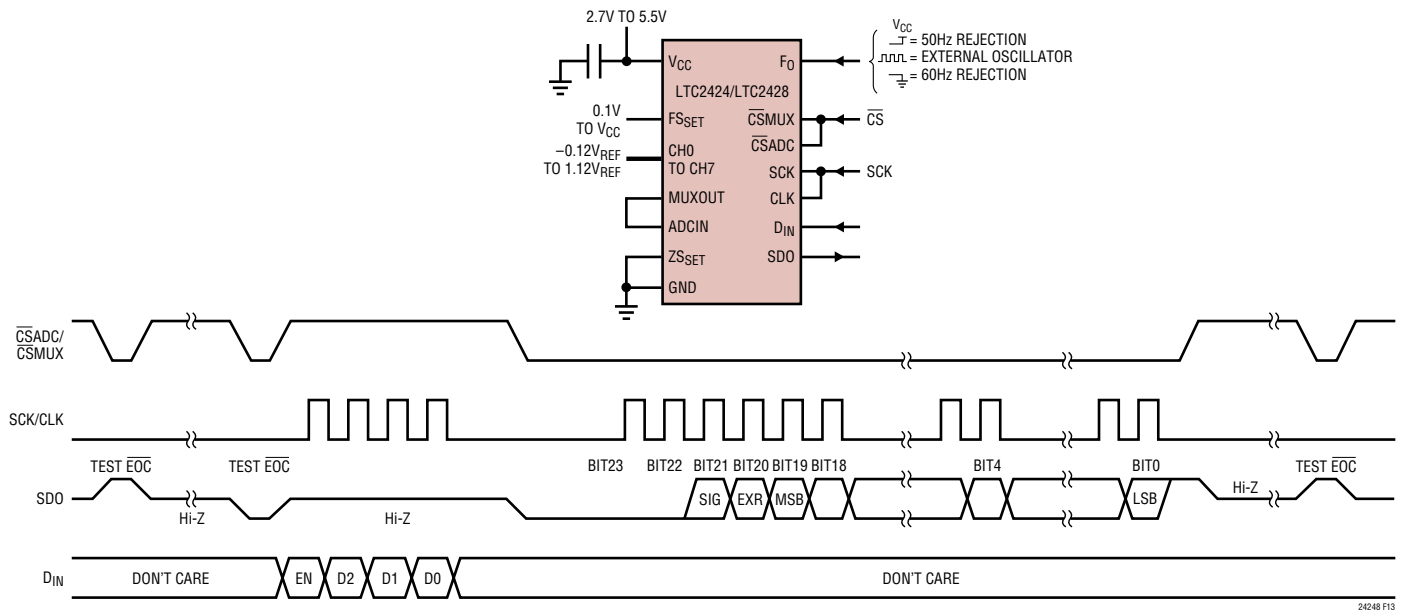

Figure 13. External Serial Clock Timing Diagram

APPLICATIONS INFORMATION

the 24th rising edge of SCK. On the 24th falling edge of SCK, the device begins a new conversion. SDO goes HIGH ($\overline{EOC} = 1$) indicating a conversion is in progress.

At the conclusion of the data cycle, \overline{CSADC} may remain LOW and \overline{EOC} monitored as an end-of-conversion interrupt. Alternatively, \overline{CSADC} may be driven HIGH setting SDO to Hi-Z. As described above, \overline{CSADC} may be pulled LOW at any time in order to monitor the conversion status. For each of these operations, \overline{CSMUX} may be tied to \overline{CSADC} without affecting the selected channel.

At the conclusion of the data output cycle, the converter enters a user transparent calibration cycle prior to actually performing a conversion on the selected input channel. This allows a 66ms (for 60Hz notch frequency) settling time for the multiplexer input. Following the data output cycle, the multiplexer input channel may be selected any time in this 66ms window by pulling \overline{CSADC} HIGH and serial shifting data into the D_{IN} pin, see Figure 14.

While the device is performing the internal calibration, it is sensitive to ground current disturbances. Error currents flowing in the ground pin may lead to offset errors. If the SCK pin is toggling during the calibration, these ground disturbances will occur. The solution is to either drive the multiplexer clock input (CLK) separately from the ADC

clock input (SCK), or program the multiplexer in the first 1ms following the data output cycle. The remaining 65ms may be used to allow the input signal to settle.

Typically, \overline{CSADC} remains LOW during the data output state. However, the data output state may be aborted by pulling \overline{CSADC} HIGH anytime between the first rising edge and the 24th falling edge of SCK, see Figure 15. On the rising edge of \overline{CSADC} , the device aborts the data output state and immediately initiates a new conversion. This is useful for systems not requiring all 24 bits of output data, aborting an invalid conversion cycle or synchronizing the start of a conversion.

Internal Serial Clock

This timing mode uses an internal serial clock to shift out the conversion result and program the multiplexer, see Figure 16. A \overline{CS} signal directly drives the \overline{CSADC} input, while the inverse of \overline{CS} drives the \overline{CSMUX} input. The \overline{CS} signal is used to monitor and control the state of the conversion cycles as well as enable the channel selection. The multiplexer is programmed during the data output state. The internal serial clock (SCK) generated by the ADC is applied to the multiplexer clock input (CLK).

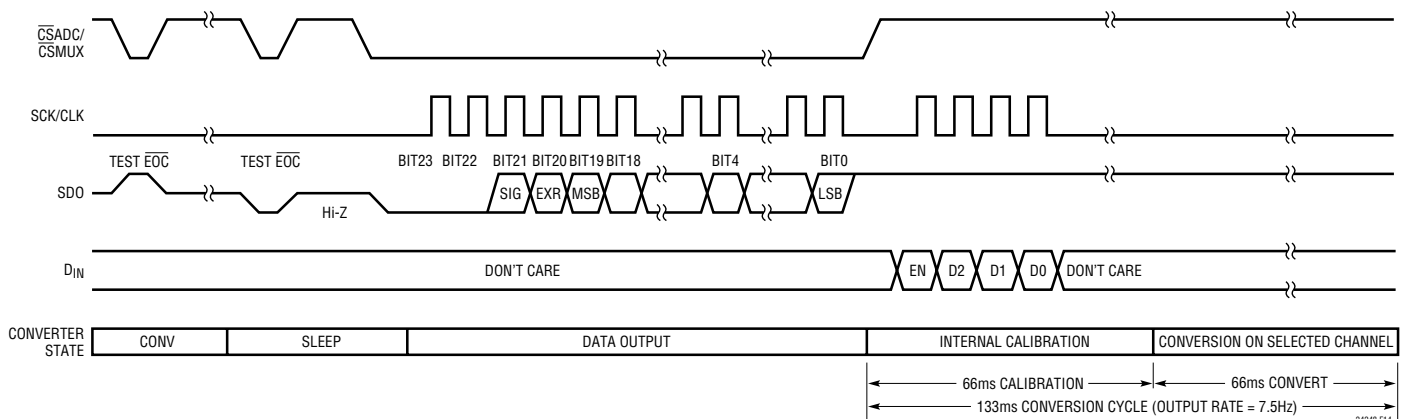

Figure 14. Use of Look Ahead to Program Multiplexer After Data Output

APPLICATIONS INFORMATION

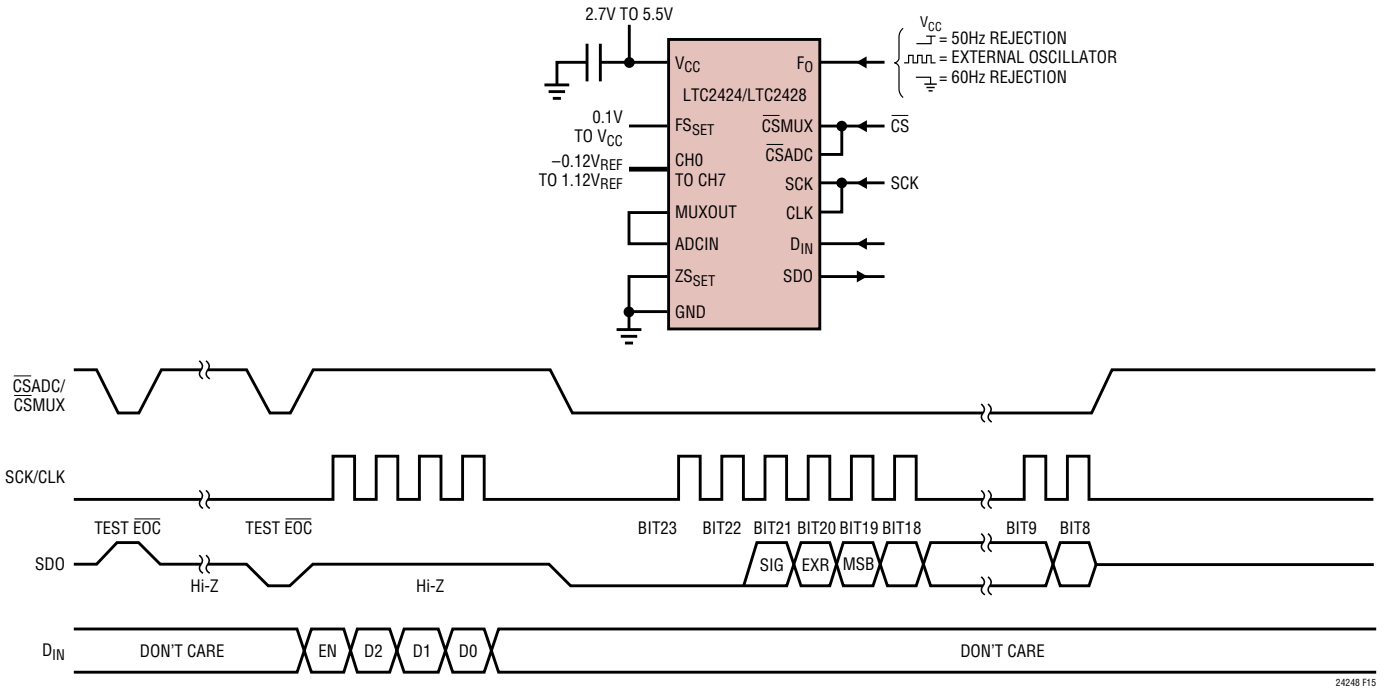

Figure 15. External Serial Clock with Reduced Data Output Length Timing Diagram

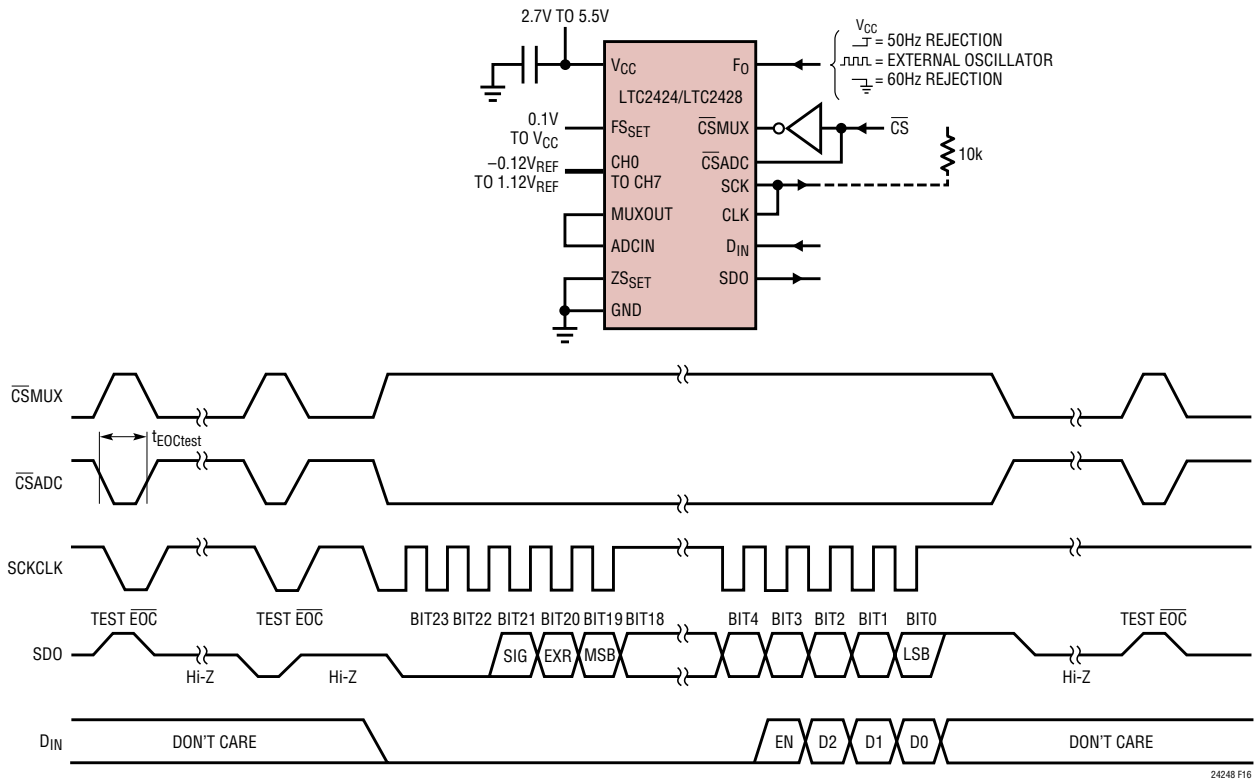

Figure 16. Internal Serial Clock Timing Diagram

APPLICATIONS INFORMATION

In order to select the internal serial clock timing mode, the serial clock pin (SCK) must be floating (Hi-Z) or pulled HIGH prior to the falling edge of $\overline{\text{CSADC}}$. The device will not enter the internal serial clock mode if SCK is driven LOW on the falling edge of $\overline{\text{CSADC}}$. An internal weak pull-up resistor is active on the SCK pin during the falling edge of $\overline{\text{CSADC}}$; therefore, the internal serial clock timing mode is automatically selected if SCK is not externally driven.

The serial data output pin (SDO) is Hi-Z as long as $\overline{\text{CSADC}}$ is HIGH. At any time during the conversion cycle, $\overline{\text{CSADC}}$ may be pulled LOW in order to monitor the state of the converter. Once $\overline{\text{CSADC}}$ is pulled LOW, SCK goes LOW and $\overline{\text{EOC}}$ is output to the SDO pin. $\overline{\text{EOC}} = 1$ while a conversion is in progress and $\overline{\text{EOC}} = 0$ if the device is in the sleep state.

When testing $\overline{\text{EOC}}$, if the conversion is complete ($\overline{\text{EOC}} = 0$), the device will exit the sleep state and enter the data output state if $\overline{\text{CSADC}}$ remains LOW. In order to prevent the device from exiting the low power sleep state, $\overline{\text{CSADC}}$ must be pulled HIGH before the first rising edge of SCK. In the internal SCK timing mode, SCK goes HIGH and the device begins outputting data at time t_{EOCtest} after the falling edge of $\overline{\text{CSADC}}$ (if $\overline{\text{EOC}} = 0$) or t_{EOCtest} after $\overline{\text{EOC}}$ goes LOW (if $\overline{\text{CSADC}}$ is LOW during the falling edge of $\overline{\text{EOC}}$). The value of t_{EOCtest} is $23\mu\text{s}$ if the device is using its internal oscillator ($F_0 = \text{logic LOW or HIGH}$). If F_0 is driven by an external oscillator of frequency f_{EOSC} , then t_{EOCtest} is $3.6/f_{\text{EOSC}}$. If $\overline{\text{CSADC}}$ is pulled HIGH before time t_{EOCtest} , the device remains in the sleep state and the power consumption is reduced an order of magnitude. The conversion result is held in the internal static shift register.

If $\overline{\text{CSADC}}$ remains LOW longer than t_{EOCtest} , the first rising edge of SCK will occur and the conversion result is serially shifted out of the SDO pin. The data output cycle begins on this first rising edge of SCK and concludes after the 24th rising edge. Data is shifted out the SDO pin on each falling edge of SCK. The internally generated serial clock is output to the SCK pin. This signal may be used to shift the conversion result into external circuitry. $\overline{\text{EOC}}$ can be latched on the first rising edge of SCK and the last bit of the conversion result on the 24th rising edge of SCK. After the

24th rising edge, SDO goes HIGH ($\overline{\text{EOC}} = 1$), SCK stays HIGH, and a new conversion starts.

While operating in the internal serial clock mode, the SCK output of the ADC may be used as the multiplexer clock (CLK). D_{IN} is latched into the multiplexer on the rising edge of CLK. As shown in Figure 16, the multiplexer channel is selected by serial shifting a 4-bit word into the D_{IN} pin on the rising edge of CLK. The first bit is an enable bit which must be HIGH in order to program a channel. The next three bits determine which channel is selected, see Table 3. On the rising edge of $\overline{\text{CSADC}}$ (falling edge of $\overline{\text{CSMUX}}$), the new channel is selected and will be valid for the next conversion. If D_{IN} is held LOW during the data output state, the previous channel selection remains valid.

Typically, $\overline{\text{CSADC}}$ remains LOW during the data output state. However, the data output state may be aborted by pulling $\overline{\text{CSADC}}$ HIGH anytime between the first and 24th rising edge of SCK, see Figure 17. On the rising edge of $\overline{\text{CSADC}}$, the device aborts the data output state and immediately initiates a new conversion. This is useful for systems not requiring all 24 bits of output data, aborting an invalid conversion cycle, or synchronizing the start of a conversion. If $\overline{\text{CSADC}}$ is pulled HIGH while the converter is driving SCK LOW, the internal pull-up is not available to restore SCK to a logic HIGH state. This will cause the device to exit the internal serial clock mode on the next falling edge of $\overline{\text{CSADC}}$. This can be avoided by adding an external 10k pull-up resistor to the SCK pin or by never pulling $\overline{\text{CSADC}}$ HIGH when SCK is LOW.

Whenever SCK is LOW, the LTC2424/LTC2428's internal pull-up at pin SCK is disabled. Normally, SCK is not externally driven if the device is in the internal SCK timing mode. However, certain applications may require an external driver on SCK. If this driver goes Hi-Z after outputting a LOW signal, the LTC2424/LTC2428's internal pull-up remains disabled. Hence, SCK remains LOW. On the next falling edge of $\overline{\text{CSADC}}$, the device is switched to the external SCK timing mode. By adding an external 10k pull-up resistor to SCK, this pin goes HIGH once the external driver goes Hi-Z. On the next $\overline{\text{CSADC}}$ falling edge, the device will remain in the internal SCK timing mode.

APPLICATIONS INFORMATION

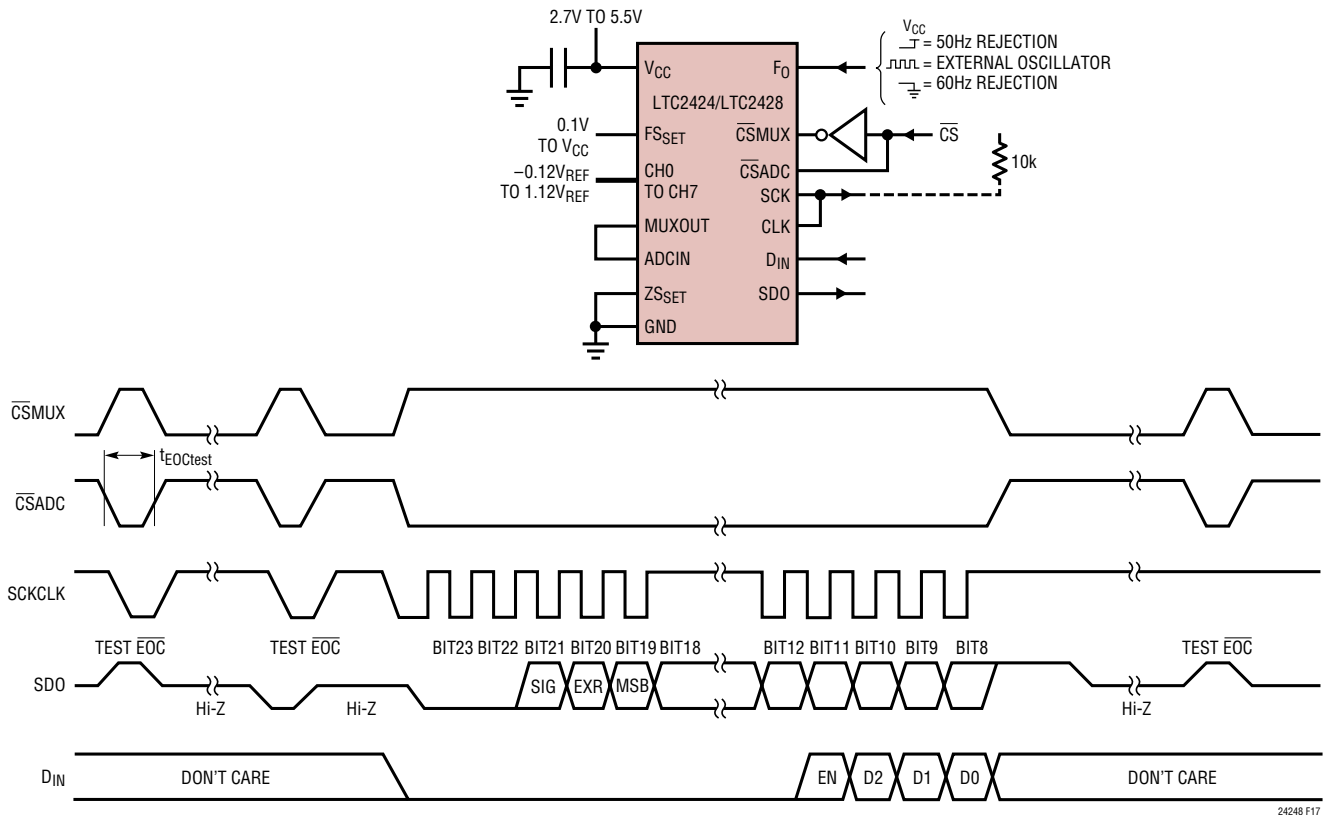

Figure 17. Internal Serial Clock with Reduced Data Output Length Timing Diagram

A similar situation may occur during the sleep state when $\overline{\text{CSADC}}$ is pulsed HIGH-LOW-HIGH in order to test the conversion status. If the device is in the sleep state ($\text{EOC} = 0$), SCK will go LOW. Once $\overline{\text{CSADC}}$ goes HIGH (within the time period defined above as t_{EOCtest}), the internal pull-up is activated. For a heavy capacitive load on the SCK pin, the internal pull-up may not be adequate to return SCK to a HIGH level before $\overline{\text{CSADC}}$ goes LOW again. This is not a concern under normal conditions where $\overline{\text{CSADC}}$ remains LOW after detecting $\text{EOC} = 0$. This situation is easily avoided by adding an external 10k pull-up resistor to the SCK pin.

DIGITAL SIGNAL LEVELS

The LTC2424/LTC2428's digital interface is easy to use. Its digital inputs (F_0 , $\overline{\text{CSADC}}$, $\overline{\text{CSMUX}}$, CLK , D_{IN} and SCK in External SCK mode of operation) accept standard TTL/CMOS logic levels and can tolerate edge rates as slow

as $100\mu\text{s}$. However, some considerations are required to take advantage of exceptional accuracy and low supply current.

The digital output signals (SDO and SCK in Internal SCK mode of operation) are less of a concern because they are not generally active during the conversion state.

In order to preserve the accuracy of the LTC2424/LTC2428, it is very important to minimize the ground path impedance which may appear in series with the input and/or reference signal and to reduce the current which may flow through this path. The ZS_{SET} pin (Pin 5) should be connected directly to the signal ground.

The power supply current during the conversion state should be kept to a minimum. This is achieved by restricting the number of digital signal transitions occurring during this period.

APPLICATIONS INFORMATION

While a digital input signal is in the 0.5V to ($V_{CC} - 0.5V$) range, the CMOS input receiver draws additional current from the power supply. It should be noted that, when any one of the digital input signals (F_0 , \overline{CSADC} , \overline{CSMUX} , D_{IN} , CLK and SCK in External SCK mode of operation) is within this range, the LTC2424/LTC2428 power supply current may increase even if the signal in question is at a valid logic level. For micropower operation and in order to minimize the potential errors due to additional ground pin current, it is recommended to drive all digital input signals to full CMOS levels [$V_{IL} < 0.4V$ and $V_{OH} > (V_{CC} - 0.4V)$].

Severe ground pin current disturbances can also occur due to the undershoot of fast digital input signals. Undershoot and overshoot can occur because of the impedance mismatch at the converter pin when the transition time of an external control signal is less than twice the propagation delay from the driver to LTC2424/LTC2428. For reference, on a regular FR-4 board, signal propagation velocity is approximately 183ps/inch for internal traces and 170ps/inch for surface traces. Thus, a driver generating a control signal with a minimum transition time of 1ns must be connected to the converter pin through a trace shorter than 2.5 inches. This problem becomes particularly difficult when shared control lines are used and multiple reflections may occur. The solution is to carefully terminate all transmission lines close to their characteristic impedance.

Parallel termination near the LTC2424/LTC2428 input pins will eliminate this problem but will increase the driver power dissipation. A series resistor between 27 Ω and 56 Ω placed near the driver or near the LTC2424/LTC2428 pin will also eliminate this problem without additional power dissipation. The actual resistor value depends upon the trace impedance and connection topology.

Driving the Input and Reference

The analog input and reference of the typical delta-sigma analog-to-digital converter are applied to a switched capacitor network. This network consists of capacitors switching between the analog input (ADCIN), ZS_{SET} (Pin 5) and the reference (FS_{SET}). The result is small current spikes seen at both ADCIN and V_{REF} . A simplified input equivalent circuit is shown in Figure 18.

The key to understanding the effects of this dynamic input current is based on a simple first order RC time constant model. Using the internal oscillator, the internal switched capacitor network of the LTC2424/LTC2428 is clocked at 153,600Hz corresponding to a 6.5 μ s sampling period. Fourteen time constants are required each time a capacitor is switched in order to achieve 1ppm settling accuracy.

Therefore, the equivalent time constant at V_{IN} and V_{REF} should be less than $6.5\mu s/14 = 460ns$ in order to achieve 1ppm accuracy.

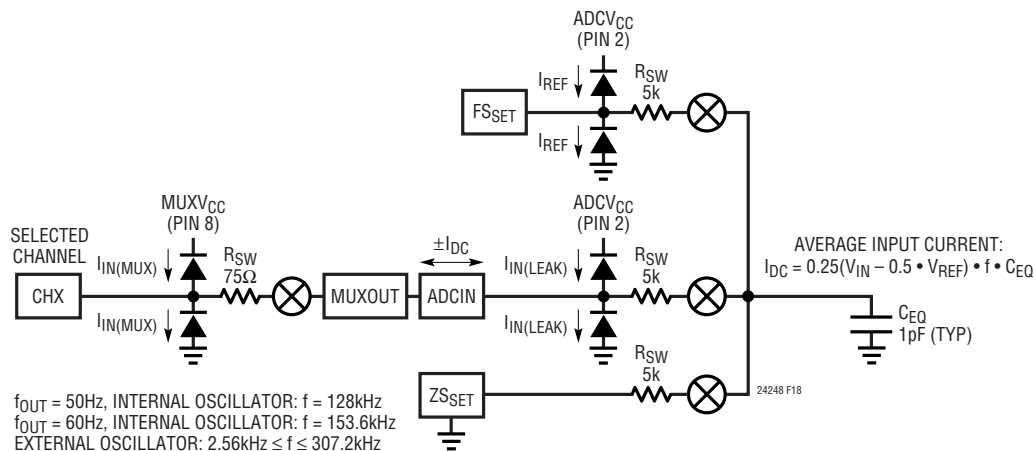

Figure 18. LTC2424/LTC2428 Equivalent Analog Input Circuit

APPLICATIONS INFORMATION

Input Current (V_{IN})

If complete settling occurs on the input, conversion results will be unaffected by the dynamic input current. If the settling is incomplete, it does not degrade the linearity performance of the device. It simply results in an offset/full-scale shift, see Figure 19. To simplify the analysis of input dynamic current, two separate cases are assumed: large capacitance at V_{IN} ($C_{IN} > 0.01\mu\text{F}$) and small capacitance at V_{IN} ($C_{IN} < 0.01\mu\text{F}$).

If the total capacitance at V_{IN} (see Figure 20) is small ($< 0.01\mu\text{F}$), relatively large external source resistances (up to 20k for 20pF parasitic capacitance) can be tolerated without any offset/full-scale error. Figures 21 and 22 show a family of offset and full-scale error curves for various small valued input capacitors ($C_{IN} < 0.01\mu\text{F}$) as a function of input source resistance.

For large input capacitor values ($C_{IN} > 0.01\mu\text{F}$), the input spikes are averaged by the capacitor into a DC current. The gain shift becomes a linear function of input source resistance independent of input capacitance, see Figures 23 and 24. The equivalent input impedance is $16.6\text{M}\Omega$.

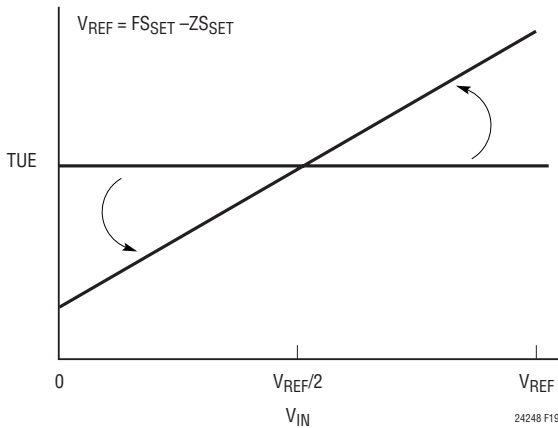

Figure 19. Offset/Full-Scale Shift

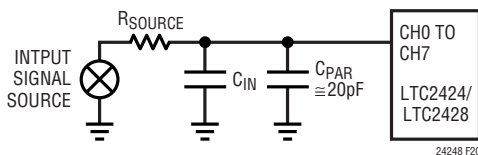

Figure 20. An RC Network at CH0 to CH7

This results in $\pm 150\text{nA}$ of input dynamic current at the extreme values of V_{IN} ($V_{IN} = 0\text{V}$ and $V_{IN} = V_{REF}$, when $V_{REF} = 5\text{V}$). This corresponds to a 0.3ppm shift in offset and full-scale readings for every 10Ω of input source resistance.

While large capacitance applied to one of the multiplexer channel inputs may result in offset/full-scale shifts, large capacitance applied to the MUXOUT/ADCIN results in linearity errors. The 75Ω on-resistance of the multiplexer switch is nonlinear with input voltage. If the capacitance at node MUXOUT/ADCIN is less than $0.01\mu\text{F}$, the linearity is not degraded. On the other hand, excessive capacitance ($> 0.01\mu\text{F}$) results in incomplete settling as a function of the multiplexer on-resistance. Hence, the

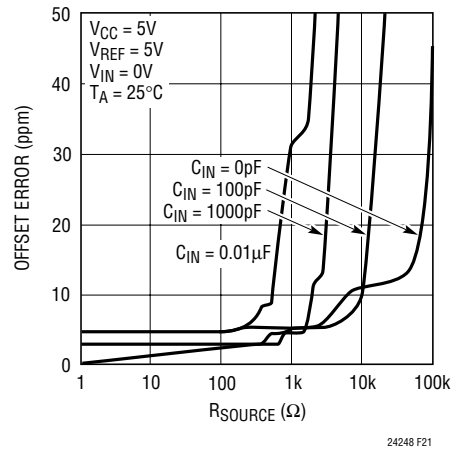

Figure 21. Offset vs R_{SOURCE} (Small C)

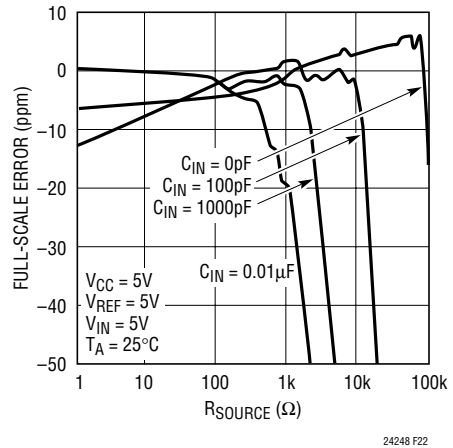
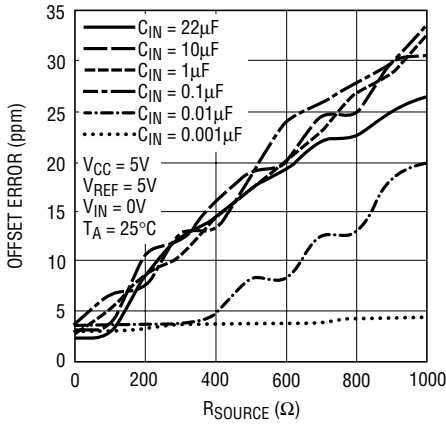
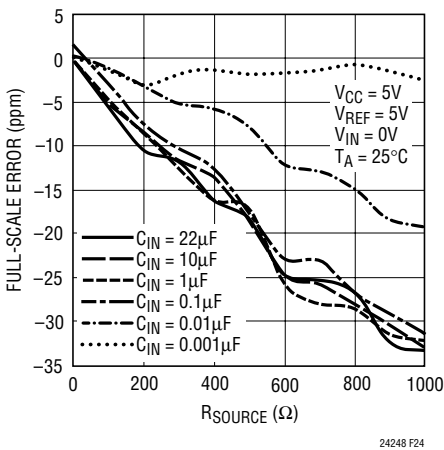

Figure 22. Full-Scale Error vs R_{SOURCE} (Small C)

APPLICATIONS INFORMATION

Figure 23. Offset vs R_{SOURCE} (Large C)Figure 24. Full-Scale Error vs R_{SOURCE} (Large C)

nonlinearity of the multiplexer switch is seen in the overall transfer characteristic.

In addition to the input current spikes, the input ESD protection diodes have a temperature dependent leakage current. This leakage current, nominally 1nA (± 10 nA max), results in a fixed offset shift of 10 μ V for a 10k source resistance.

Reference Current (V_{REF})

Similar to the analog input, the reference input has a dynamic input current. This current has negligible effect on the offset. However, the reference current at $V_{IN} = V_{REF}$ is similar to the input current at full-scale. For large values of reference capacitance ($C_{VREF} > 0.01\mu\text{F}$), the full-scale

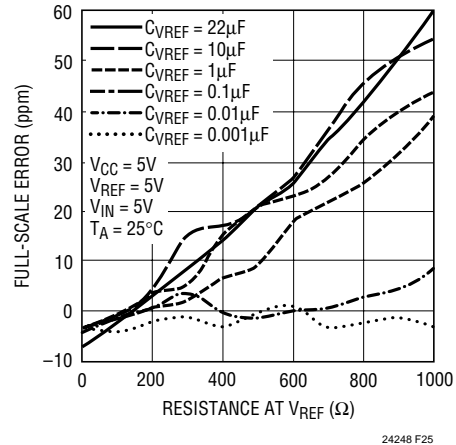
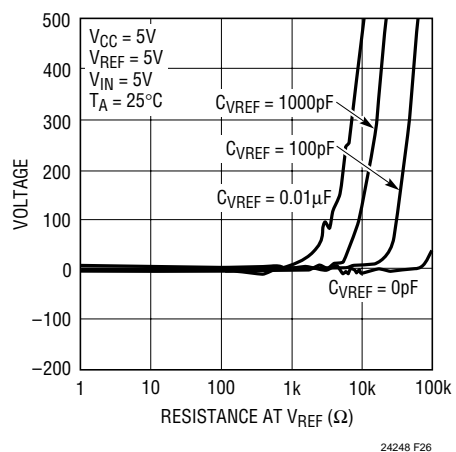
Figure 25. Full-Scale Error vs R_{VREF} (Large C)Figure 26. Full-Scale Error vs R_{VREF} (Small C)

error shift is 0.03ppm/ Ω of external reference resistance independent of the capacitance at V_{REF} , see Figure 25. If the capacitance tied to V_{REF} is small ($C_{VREF} < 0.01\mu\text{F}$), an input resistance of up to 80k (20pF parasitic capacitance at V_{REF}) may be tolerated, see Figure 26.

Unlike the analog input, the integral nonlinearity of the device can be degraded with excessive external RC time constants tied to the reference input. If the capacitance at node V_{REF} is small ($C_{VREF} < 0.01\mu\text{F}$), the reference input can tolerate large external resistances without reduction in INL, see Figure 27. If the external capacitance is large ($C_{VREF} > 0.01\mu\text{F}$), the linearity will be degraded by 0.015ppm/ Ω independent of capacitance at V_{REF} , see Figure 28.

APPLICATIONS INFORMATION

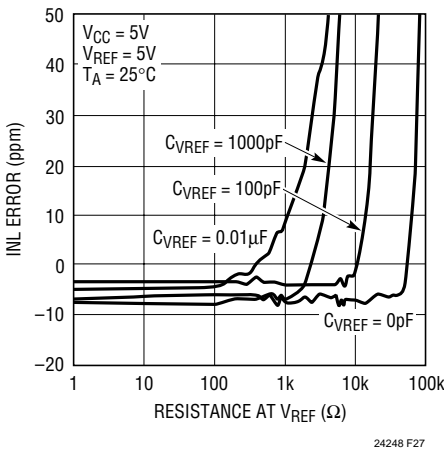

Figure 27. INL Error vs R_{VREF} (Small C)

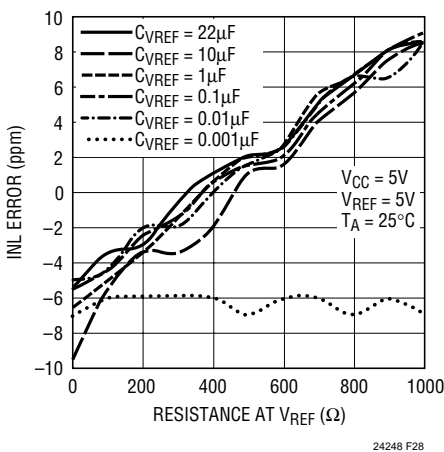

Figure 28. INL Error vs R_{VREF} (Large C)

In addition to the dynamic reference current, the V_{REF} ESD protection diodes have a temperature dependent leakage current. This leakage current, nominally 1nA (±10nA max), results in a fixed full-scale shift of 10μV for a 10k source resistance.

Antialiasing

One of the advantages delta-sigma ADCs offer over conventional ADCs is on-chip digital filtering. Combined with a large oversampling ratio, the LTC2424/LTC2428 significantly simplify antialiasing filter requirements.

The digital filter provides very high rejection except at integer multiples of the modulator sampling frequency (f_s), see Figure 29. The modulator sampling frequency is

256 • F₀, where F₀ is the notch frequency (typically 50Hz or 60Hz). The bandwidth of signals not rejected by the digital filter is narrow (≈ 0.2%) compared to the bandwidth of the frequencies rejected.

As a result of the oversampling ratio (256) and the digital filter, minimal (if any) antialias filtering is required in front of the LTC2424/LTC2428. If passive RC components are placed in front of the LTC2424/LTC2428, the input dynamic current should be considered. In cases where large effective RC time constants are used, an external buffer amplifier may be required to minimize the effects of input dynamic current.

The modulator contained within the LTC2424/LTC2428 can handle large-signal level perturbations without saturating. Signal levels up to 40% of V_{REF} do not saturate the analog modulator. These signals are limited by the input ESD protection to 300mV below ground and 300mV above V_{CC}.

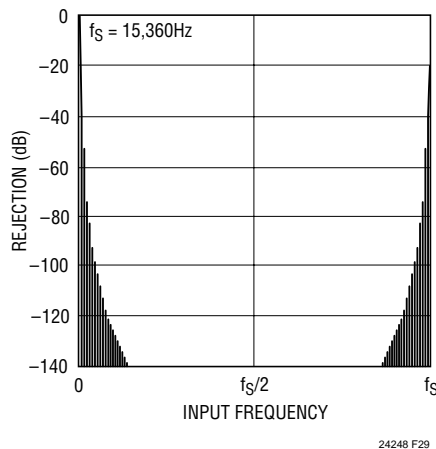

Figure 29. Sync⁴ Filter Rejection

Using a Low Power Precision Reference

The circuit in Figure 30 shows the connections and bypassing for an LT1461-2.5 as a 2.5V reference. The LT1461 is a bandgap reference capable of 3ppm/°C temperature stability yet consumes only 45μA of current. The 1k resistor between the reference and the ADC reduces the transient load changes associated with sampling and produces optimal results. This reference will not impact the noise level of the LTC2424/LTC2428 if signals are less

APPLICATIONS INFORMATION

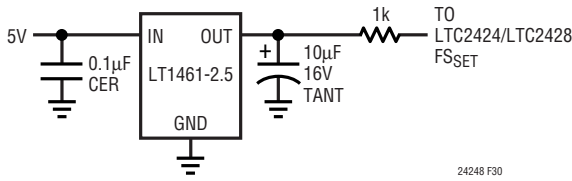

Figure 30. Low Power Reference

than 60% full scale, and only marginally increases noise approaching full scale. Even lower power references can be used if only the lower end of the LTC2424/LTC2428 input range is required.

2.051MHz Oscillator for 100sps Output Ratio

The oscillator circuit shown in Figure 31 can be used to drive the F_0 pin, boosting the conversion rate of the LTC2420 for applications that do not require a notch at 50 or 60Hz. This oscillator is not sensitive to hysteresis voltage of a Schmitt trigger device as are simpler relaxation oscillators using the 74HC14 or similar devices. The circuit can be tuned over a 3-1 range with only one resistor and can be gated. The use of transmission gates could be used to shift the frequency in order to provide settable conversion rates.

Pseudodifferential Multichannel Bridge Digitizer and Digital Cold Junction Compensation

The circuit shown in Figure 32 enables pseudodifferential measurements of several bridge transducers and absolute temperature measurement.

Consecutive readings are performed on each side of the bridge by selecting the appropriate channel on the LTC2428. Each output is digitized and the results digitally subtracted to obtain the pseudodifferential result. Several bridge transducers may be digitized in this manner.

In order to measure absolute temperature with a thermocouple, cold junction compensation must be performed. Channel 6 measures the output of the thermocouple while channel 7 measures the output of the cold junction sensor (diode, thermistor, etc.). This enables digital cold junction compensation of the thermocouple output. The temperature measurement may then be used to compensate the temperature effects of the bridge transducers.

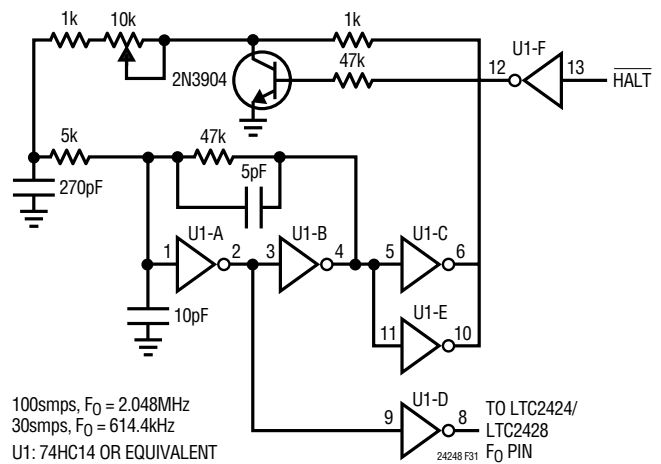

Figure 31. 2.051MHz Oscillator for 100sps Output Rate

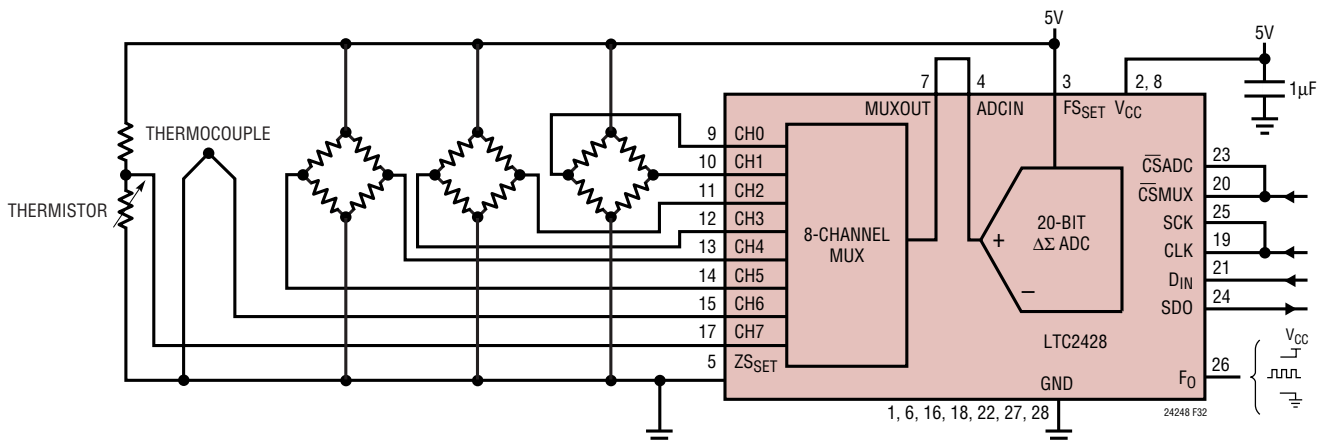

Figure 32. Pseudodifferential Multichannel Bridge Digitizer and Digital Cold Junction Compensation

APPLICATIONS INFORMATION

Adding gain requires that one of the resistors (PT1 to PT7) be a precision resistor in order to eliminate the error associated with the gain setting resistors R2 and R3. Note, that if a precision (100Ω to 400Ω) resistor is used in place of one of the RTDs (PT7 recommended), R1 does not need to be a high precision resistor. Although the substitution of a precision reference resistor for an RTD to determine gain may suggest that R2 and R3 (and R1) need not be precise, temperature fluctuations due to airflow may appear as noise that cannot be removed in firmware. Consequently, these resistors should be low temperature coefficient devices. The use of higher resistance RTDs is not recommended in this topology, although the inclusion of one 1000Ω RTD at the top on the ladder will have minimal impact on the lower elements. The same caveat applies to fast changing temperatures. Any fast changing sensors should be at the top of the ladder.

The LTC2428's Uncommitted Multiplexer Finds Use in a Programmable Gain Scheme

If the multiplexer in the LTC2428 is not committed to channel selection, it can be used to select various signal-processing options such as different gains, filters or attenuator characteristics. In Figure 34, the multiplexer is shown selecting different taps on an R/2R ladder in the feedback loop of an amplifier. This example allows selection of gain from 1 to 128 in binary steps. Other feedback networks could be used to provide gains tailored for specific purposes. (For example, 1x, 1.1x, 1.41x, 2x, 2.028x, 5x, 10x, 40x, etc.) Alternatively, different bandpass characteristics or signal inversion/noninversion could be selected. The R/2R ladder can be purchased as a network to ensure tight temperature tracking. Alternatively, resistors in a ladder or as separate dividers can be assembled from discrete resistors. In the configuration shown, the

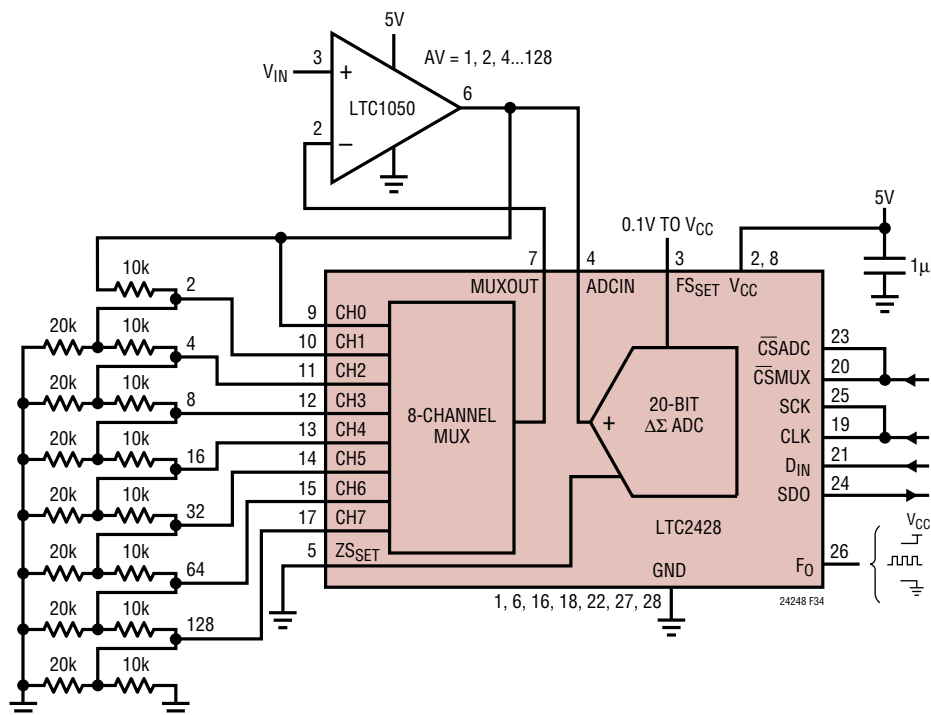

Figure 34. Using the Multiplexer to Produce Programmable Gains of 1 to 128

APPLICATIONS INFORMATION

An 8-Channel DC-to-Daylight Digitizer

The circuit in Figure 36 shows an example of the LTC2428's flexibility in digitizing a number of real-world physical phenomena—from DC voltages to ultraviolet light. All of the examples implement single-ended signal conditioning. Although differential signal conditioning is a preferred approach in applications where the sensor is a bridge-type, is located some distance from the ADC or operates in a high ambient noise environment, the LTC2428's low power dissipation allows circuit operation in close proximity to the sensor. As a result, conditioning the sensor output can be greatly simplified through the use of single-ended arrangements. In those applications where differential signal conditioning is required, chopper amplifier-based or self-contained instrumentation amplifiers (also available from LTC) can be used with the LTC2428.

With the resistor network connected to CH0, the LTC2428 is able to measure DC voltages from 1mV to 1kV in a single range without the need for autoranging. The 990k resistor should be a 1W resistor rated for high voltage operation. Alternatively, the 990k resistor can be replaced with a series connection of several lower cost, lower power metal film resistors.

The circuit connected to CH1 shows an LT1793 FET input operational amplifier used as an electrometer for high impedance, low frequency applications such as measuring pH. The circuit has been configured for a gain of 21; thus, the input signal range is $-15\text{mV} \leq V_{\text{IN}} \leq 250\text{mV}$. An amplifier circuit is necessary in these applications because high output impedance sensors cannot drive switched-capacitor ADCs directly. The LT1793 was chosen for its low input bias current (10pA, max) and low noise (8nV/ $\sqrt{\text{Hz}}$) performance. As shown, the use of a driven guard (and Teflon™ standoffs) is recommended in high impedance sensor applications; otherwise, PC board surface leakage current effects can degrade results.

The circuit connected to CH2 illustrates a precision half-wave rectifier that uses the LTC2428's internal $\Delta\Sigma$ ADC as an integrator. This circuit can be used to measure 60Hz,

120Hz or from 400Hz to 1kHz with good results. The LTC2428's internal sinc⁴ filter effectively eliminates any frequency in this range. Above 1kHz, limited amplifier gain-bandwidth product and transient overshoot behavior can combine to degrade performance. The circuit's dynamic range is limited by operational amplifier input offset voltage and the system's overall noise floor. Using an LTC1050 chopper-stabilized operational amplifier with a V_{OS} of 5 μV , the dynamic range of this application covers approximately 5 orders of magnitude. The circuit configuration is best implemented with a precision, 3-terminal, 2-resistor 10k Ω network (for example, an IRC PFC-D network) for R6 and R7 to maintain gain and temperature stability. Alternatively, discrete resistors with 0.1% initial tolerance and 5ppm/ $^{\circ}\text{C}$ temperature coefficient would also be adequate for most applications.

Two channels (CH3 and CH4) of the LTC2428 are used to accommodate a 3-wire 100 Ω , Pt RTD in a unique circuit that allows true RMS/RF signal power measurement from audio to gigahertz (GHz) frequencies. The unique feature of this circuit is that the signal power dissipated in the 50 Ω termination in the form of heat is measured by the 100 Ω RTD. Two readings are required to compensate for the RTD's lead-wire resistance. The reading on CH4 is multiplied by 2 and subtracted from the reading on CH3 to determine the exact value of the RTD.

While the LTC2428 is capable of measuring signals over a range of five decades, the implementation (mechanical, electrical and thermal) of this technique ultimately determines the performance of the circuit. The thermal resistance of the assembly (the 50 Ω /RTD mass to its enclosure) will determine the sensitivity of the circuit. The dynamic range of the circuit will be determined by the maximum temperature the assembly is rated to withstand, approximately 850 $^{\circ}\text{C}$. Details of the implementation are quite involved and are beyond the scope of this document. Please contact LTC directly for a more comprehensive treatment of this implementation.

In the circuit connected to the LTC2428's CH5 input, a thermistor is configured in a half-bridge arrangement that

Teflon is a trademark of Dupont Company.

APPLICATIONS INFORMATION

could be used to measure the case temperature of the RTD-based thermal power measurement scheme described previously. In general, thermistors yield very good resolution over a limited temperature range. For the half-bridge arrangement shown, the LTC2428 can measure temperature changes over nearly 5 orders of magnitude.

Connected to the LTC2428's CH6 input, an infrared thermocouple (Omega Engineering OS36-1) can be used in limited range, noncontact temperature measurement applications or applications where high levels of infrared light must be measured. Given the LTC2428's $1.2\text{ppm}_{\text{RMS}}$ noise performance, measurement resolution using infrared thermocouples is approximately 0.25°C —equivalent to the resolution of a conventional Type J thermocouple. These infrared thermocouples are self-contained: 1) they do not require external cold junction compensation; 2) they cannot use conventional open thermocouple detection schemes; and 3) their output impedances are high, approximately $3\text{k}\Omega$. Alternatively, conventional thermocouples can be connected directly to the LTC2428 (not shown) and cold junction compensation can be provided by an external temperature sensor connected to a different

channel (see the thermistor circuit on CH5) or by using the LT1025, a monolithic cold-junction compensator IC.

The components connected to CH7 are used to sense daylight or photodiode current with a resolution of 300pA . In the figure, the photodiode is biased in photoconductive mode; however, the LTC2428 can accommodate either photovoltaic or photoconductive configurations. The photodiode chosen (Hamamatsu S1336-5BK) produces an output of 500mA per watt of optical illumination. The output of the photodiode is dependent on two factors: active detector area ($2.4\text{mm} \cdot 2.4\text{mm}$) and illumination intensity. With the 5k resistor, optical intensities up to $368\text{W}/\text{m}^2$ at 960nm (direct sunlight is approximately $1000\text{W}/\text{m}^2$) can be measured by the LTC2428. With a resolution of 1nA , the optical dynamic range covers 5 orders of magnitude.

The application circuits shown connected to the LTC2428 demonstrate the mix-and-match capabilities of this multiplexed-input, high resolution $\Delta\Sigma$ ADC. Very low level signals and high level signals can be accommodated with a minimum of additional circuitry.

PACKAGE DESCRIPTION Dimensions in millimeters (inches) unless otherwise noted.

G Package
28-Lead Plastic SSOP (0.209)
 (LTC DWG # 05-08-1640)

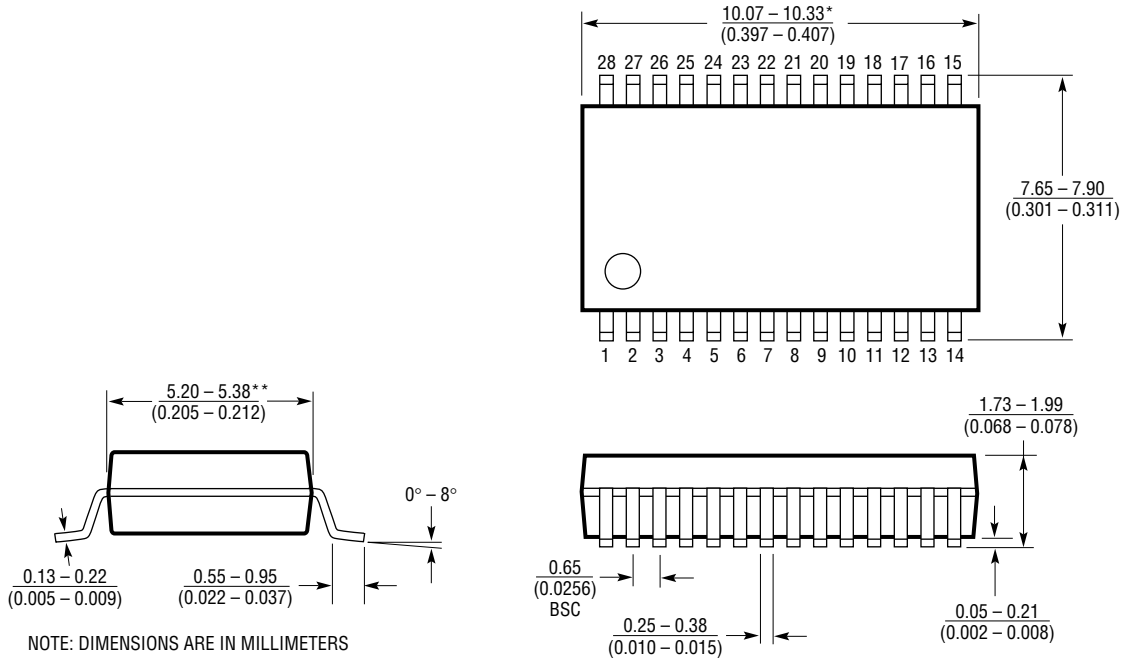

NOTE: DIMENSIONS ARE IN MILLIMETERS
 *DIMENSIONS DO NOT INCLUDE MOLD FLASH. MOLD FLASH SHALL NOT EXCEED 0.152mm (0.006") PER SIDE
 **DIMENSIONS DO NOT INCLUDE INTERLEAD FLASH. INTERLEAD FLASH SHALL NOT EXCEED 0.254mm (0.010") PER SIDE

G28 SSOP 1098

TYPICAL APPLICATION

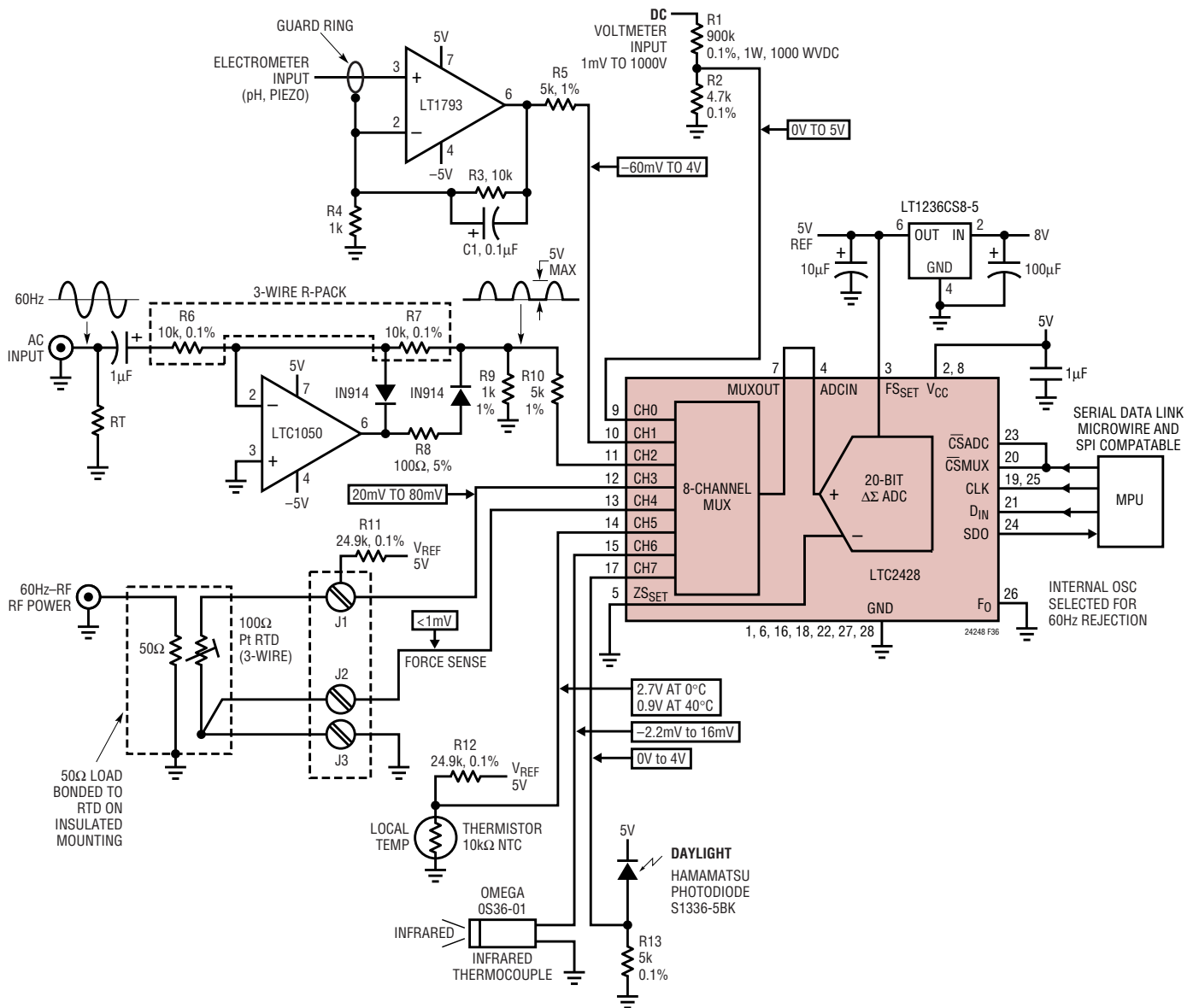

Figure 36. Measure DC to Daylight Using the LTC2428

RELATED PARTS

PART NUMBER	DESCRIPTION	COMMENTS
LTC2400	24-Bit μ Power, No Latency $\Delta\Sigma$ ADC in SO-8	4ppm INL, 10ppm TUE, 200 μ A, Pin Compatible with LTC2420
LTC2401/LTC2402	1-/2-Channel, 24-Bit No Latency $\Delta\Sigma$ ADCs	24 Bits in MSOP Package
LTC2410	24-Bit No Latency $\Delta\Sigma$ ADC with Differential Inputs	800nV Noise, Differential Reference, 2.7V to 5.5V Operation
LTC2411	24-Bit No Latency $\Delta\Sigma$ ADC with Differential Inputs/Reference	1.6 μ V Noise, Fully Differential, 10-Lead MSOP Package
LTC2413	24-Bit No Latency $\Delta\Sigma$ ADC	Simultaneous 50Hz to 60Hz Rejection 0.16ppm Noise
LTC2404/LTC2408	4/8 Channel, 24-Bit $\Delta\Sigma$ ADCs	<4ppm INL, No Missing Codes
LTC2420	20-Bit No Latency $\Delta\Sigma$ ADC	Fast Mode Allows 100sps, Low Cost

Looking for pricing, stock, or lifecycle information?

Click below to explore more details on WIN SOURCE:

 [View LTC2424IG#PBF on WIN SOURCE](#)

 [Linear Technology](#) Information

Optimize Your Supply Chain with WIN SOURCE Solutions

-  Global Sourcing Solution
-  Obsolete Management
-  Cost Control Management
-  Shortage Management
-  Alternative Solution
-  Excess Inventory Management