



**THE DATASHEET OF
LTC2364CMS-16#PBF**



16-Bit, 250ksps, Pseudo-Differential Unipolar SAR ADC with 94.7dB SNR

FEATURES

- 250ksps Throughput Rate
- $\pm 0.75\text{LSB}$ INL (Max)
- Guaranteed 16-Bit No Missing Codes
- Low Power: 3.4mW at 250ksps, 3.4 μW at 250sps
- 94.7dB SNR (Typ) at $f_{\text{IN}} = 2\text{kHz}$
- -120dB THD (Typ) at $f_{\text{IN}} = 2\text{kHz}$
- Guaranteed Operation to 125°C
- 2.5V Supply
- Pseudo-Differential Unipolar Input Range: 0V to V_{REF}
- V_{REF} Input Range from 2.5V to 5.1V
- No Pipeline Delay, No Cycle Latency
- 1.8V to 5V I/O Voltages
- SPI-Compatible Serial I/O with Daisy-Chain Mode
- Internal Conversion Clock
- 16-Lead MSOP and 4mm \times 3mm DFN Packages

APPLICATIONS

- Medical Imaging
- High Speed Data Acquisition
- Portable or Compact Instrumentation
- Industrial Process Control
- Low Power Battery-Operated Instrumentation
- ATE

DESCRIPTION

The LTC[®]2364-16 is a low noise, low power, high speed 16-bit successive approximation register (SAR) ADC. Operating from a 2.5V supply, the LTC2364-16 has a 0V to V_{REF} pseudo-differential unipolar input range with V_{REF} ranging from 2.5V to 5.1V. The LTC2364-16 consumes only 3.4mW and achieves $\pm 0.75\text{LSB}$ INL maximum, no missing codes at 16 bits with 94.7dB SNR.

The LTC2364-16 has a high speed SPI-compatible serial interface that supports 1.8V, 2.5V, 3.3V and 5V logic while also featuring a daisy-chain mode. The fast 250ksps throughput with no cycle latency makes the LTC2364-16 ideally suited for a wide variety of high speed applications. An internal oscillator sets the conversion time, easing external timing considerations. The LTC2364-16 automatically powers down between conversions, leading to reduced power dissipation that scales with the sampling rate.

LT, LT, LTC, LTM, Linear Technology and the Linear logo are registered trademarks and SoftSpan is a trademark of Linear Technology Corporation. All other trademarks are the property of their respective owners. Protected by U.S. Patents, including 7705765.

TYPICAL APPLICATION

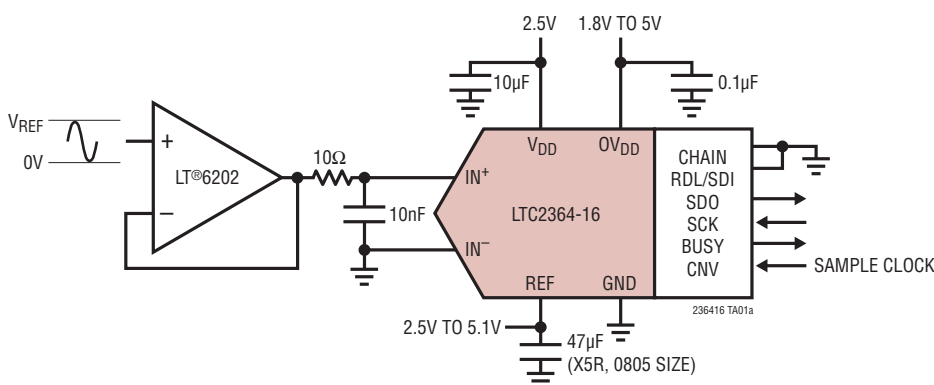

32k Point FFT $f_s = 250\text{ksps}$, $f_{\text{IN}} = 2\text{kHz}$

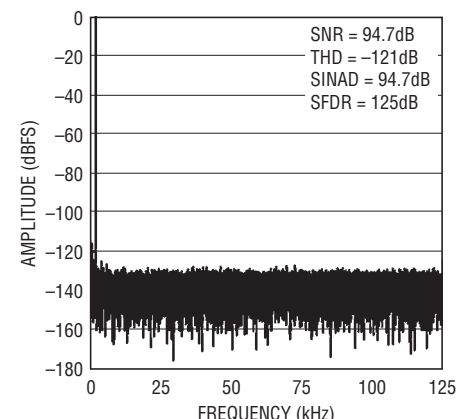

LTC2364-16

ABSOLUTE MAXIMUM RATINGS (Notes 1, 2)

Supply Voltage (V_{DD})	2.8V	Power Dissipation	500mW
Supply Voltage (OV_{DD})	6V	Operating Temperature Range	
Reference Input (REF)	6V	LTC2364C	0°C to 70°C
Analog Input Voltage (Note 3)		LTC2364I	-40°C to 85°C
IN^+ , IN^-	(GND - 0.3V) to (REF + 0.3V)	LTC2364H	-40°C to 125°C
Digital Input Voltage		Storage Temperature Range	-65°C to 150°C
(Note 3)	(GND - 0.3V) to (OV_{DD} + 0.3V)		
Digital Output Voltage			
(Note 3)	(GND - 0.3V) to (OV_{DD} + 0.3V)		

PIN CONFIGURATION

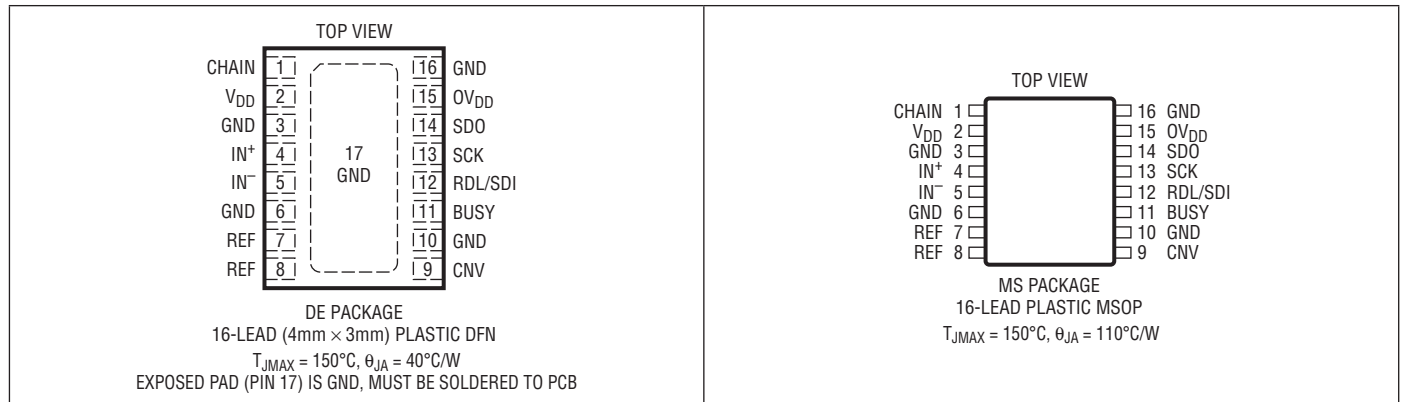

ORDER INFORMATION

LEAD FREE FINISH	TAPE AND REEL	PART MARKING*	PACKAGE DESCRIPTION	TEMPERATURE RANGE
LTC2364CMS-16#PBF	LTC2364CMS-16#TRPBF	236416	16-Lead Plastic MSOP	0°C to 70°C
LTC2364IMS-16#PBF	LTC2364IMS-16#TRPBF	236416	16-Lead Plastic MSOP	-40°C to 85°C
LTC2364HMS-16#PBF	LTC2364HMS-16#TRPBF	236416	16-Lead Plastic MSOP	-40°C to 125°C
LTC2364CDE-16#PBF	LTC2364CDE-16#TRPBF	23646	16-Lead (4mm × 3mm) Plastic DFN	0°C to 70°C
LTC2364IDE-16#PBF	LTC2364IDE-16#TRPBF	23646	16-Lead (4mm × 3mm) Plastic DFN	-40°C to 85°C

Consult LTC Marketing for parts specified with wider operating temperature ranges. *The temperature grade is identified by a label on the shipping container.

Consult LTC Marketing for information on non-standard lead based finish parts.

For more information on lead free part marking, go to: <http://www.linear.com/leadfree/>

For more information on tape and reel specifications, go to: <http://www.linear.com/tapeandreel/>

ELECTRICAL CHARACTERISTICS

The ● denotes the specifications which apply over the full operating temperature range, otherwise specifications are at $T_A = 25^\circ\text{C}$. (Note 4)

SYMBOL	PARAMETER	CONDITIONS	MIN	TYP	MAX	UNITS
V_{IN+}	Absolute Input Range (IN^+)	(Note 5) ●	-0.1		$V_{REF} + 0.1$	V
V_{IN-}	Absolute Input Range (IN^-)	(Note 5) ●	-0.1		0.1	V
$V_{IN+} - V_{IN-}$	Input Differential Voltage Range	$V_{IN} = V_{IN+} - V_{IN-}$ ●	0		V_{REF}	V
I_{IN}	Analog Input Leakage Current	●			± 1	μA
C_{IN}	Analog Input Capacitance	Sample Mode Hold Mode		45 5		pF pF
CMRR	Input Common Mode Rejection Ratio	$f_{IN} = 125\text{kHz}$		80		dB

CONVERTER CHARACTERISTICS

The ● denotes the specifications which apply over the full operating temperature range, otherwise specifications are at $T_A = 25^\circ\text{C}$. (Note 4)

SYMBOL	PARAMETER	CONDITIONS	MIN	TYP	MAX	UNITS
	Resolution	●	16			Bits
	No Missing Codes	●	16			Bits
	Transition Noise			0.5		LSB_{RMS}
INL	Integral Linearity Error	(Note 6) ●	-0.75	± 0.1	0.75	LSB
DNL	Differential Linearity Error	●	-0.5	± 0.1	0.5	LSB
ZSE	Zero-Scale Error	(Note 7) ●	-4	0	4	LSB
	Zero-Scale Error Drift			4		$\text{mLSB}/^\circ\text{C}$
FSE	Full-Scale Error	(Note 7) ●	-20	± 2	20	LSB
	Full-Scale Error Drift			± 0.1		$\text{ppm}/^\circ\text{C}$

DYNAMIC ACCURACY

The ● denotes the specifications which apply over the full operating temperature range, otherwise specifications are at $T_A = 25^\circ\text{C}$ and $A_{IN} = -1\text{dBFS}$. (Notes 4, 8)

SYMBOL	PARAMETER	CONDITIONS	MIN	TYP	MAX	UNITS	
SINAD	Signal-to-(Noise + Distortion) Ratio	$f_{IN} = 2\text{kHz}$, $V_{REF} = 5\text{V}$ ●	91.9	94.7		dB	
		$f_{IN} = 2\text{kHz}$, $V_{REF} = 5\text{V}$, (H-Grade) ●	91.7	94.7		dB	
SNR	Signal-to-Noise Ratio	$f_{IN} = 2\text{kHz}$, $V_{REF} = 5\text{V}$ ●	92.5	94.7		dB	
		$f_{IN} = 2\text{kHz}$, $V_{REF} = 2.5\text{V}$ ●	87.7	90.7		dB	
		$f_{IN} = 2\text{kHz}$, $V_{REF} = 5\text{V}$, (H-Grade) ●	92.2	94.7		dB	
		$f_{IN} = 2\text{kHz}$, $V_{REF} = 2.5\text{V}$, (H-Grade) ●	87.3	90.7		dB	
THD	Total Harmonic Distortion	$f_{IN} = 2\text{kHz}$, $V_{REF} = 5\text{V}$ ●		-120	-102	dB	
		$f_{IN} = 2\text{kHz}$, $V_{REF} = 2.5\text{V}$ ●		-120	-102	dB	
SFDR	Spurious Free Dynamic Range	$f_{IN} = 2\text{kHz}$, $V_{REF} = 5\text{V}$ ●	103	122		dB	
		-3dB Input Bandwidth		34		MHz	
		Aperture Delay		500		ps	
		Aperture Jitter		4		ps	
		Transient Response	Full-Scale Step		3.46		μs

REFERENCE INPUT

The ● denotes the specifications which apply over the full operating temperature range, otherwise specifications are at $T_A = 25^\circ\text{C}$. (Note 4)

SYMBOL	PARAMETER	CONDITIONS	MIN	TYP	MAX	UNITS
V_{REF}	Reference Voltage	(Note 5)	● 2.5		5.1	V
I_{REF}	Reference Input Current	(Note 9)	●	0.12	0.2	mA

DIGITAL INPUTS AND DIGITAL OUTPUTS

The ● denotes the specifications which apply over the full operating temperature range, otherwise specifications are at $T_A = 25^\circ\text{C}$. (Note 4)

SYMBOL	PARAMETER	CONDITIONS	MIN	TYP	MAX	UNITS
V_{IH}	High Level Input Voltage		● $0.8 \cdot OV_{DD}$			V
V_{IL}	Low Level Input Voltage				● $0.2 \cdot OV_{DD}$	V
I_{IN}	Digital Input Current	$V_{IN} = 0V$ to OV_{DD}	● -10		10	μA
C_{IN}	Digital Input Capacitance			5		pF
V_{OH}	High Level Output Voltage	$I_O = -500\mu\text{A}$	● $OV_{DD} - 0.2$			V
V_{OL}	Low Level Output Voltage	$I_O = 500\mu\text{A}$	●		0.2	V
I_{OZ}	Hi-Z Output Leakage Current	$V_{OUT} = 0V$ to OV_{DD}	● -10		10	μA
I_{SOURCE}	Output Source Current	$V_{OUT} = 0V$		-10		mA
I_{SINK}	Output Sink Current	$V_{OUT} = OV_{DD}$		10		mA

POWER REQUIREMENTS

The ● denotes the specifications which apply over the full operating temperature range, otherwise specifications are at $T_A = 25^\circ\text{C}$. (Note 4)

SYMBOL	PARAMETER	CONDITIONS	MIN	TYP	MAX	UNITS
V_{DD}	Supply Voltage		● 2.375	2.5	2.625	V
OV_{DD}	Supply Voltage		● 1.71		5.25	V
I_{VDD}	Supply Current	250ksps Sample Rate	●	1.36	1.7	mA
I_{OVDD}	Supply Current	250ksps Sample Rate ($C_L = 20\text{pF}$)	●	0.1		mA
I_{PD}	Power Down Mode	Conversion Done ($I_{VDD} + I_{OVDD} + I_{REF}$, $V_{REF} > 2V$)	●	0.9	90	μA
I_{PD}	Power Down Mode	Conversion Done ($I_{VDD} + I_{OVDD} + I_{REF}$, $V_{REF} > 2V$, H-Grade)	●	0.9	140	μA
P_D	Power Dissipation	250ksps Sample Rate		3.4	4.25	mW
	Power Down Mode	Conversion Done ($I_{VDD} + I_{OVDD} + I_{REF}$, $V_{REF} > 2V$)		2.25	225	μW
	Power Down Mode	Conversion Done ($I_{VDD} + I_{OVDD} + I_{REF}$, $V_{REF} > 2V$, H-Grade)		2.25	315	μW

ADC TIMING CHARACTERISTICS

The ● denotes the specifications which apply over the full operating temperature range, otherwise specifications are at $T_A = 25^\circ\text{C}$. (Note 4)

SYMBOL	PARAMETER	CONDITIONS	MIN	TYP	MAX	UNITS
f_{SAMPL}	Maximum Sampling Frequency		●		250	ksps
t_{CONV}	Conversion Time		● 1.9		3	μs
t_{ACQ}	Acquisition Time	$t_{ACQ} = t_{CYC} - t_{HOLD}$ (Note 10)	● 3.460			μs
t_{HOLD}	Maximum Time Between Acquisitions		●		540	ns
t_{CYC}	Time Between Conversions		● 4			μs
t_{CNVH}	CNV High Time		● 20			ns
$t_{BUSY\text{LH}}$	CNV \uparrow to BUSY Delay	$C_L = 20\text{pF}$	●		13	ns
t_{CNVL}	Minimum Low Time for CNV	(Note 11)	● 20			ns
t_{QUIET}	SCK Quiet Time from CNV \uparrow	(Note 10)	● 20			ns

ADC TIMING CHARACTERISTICS

The ● denotes the specifications which apply over the full operating temperature range, otherwise specifications are at $T_A = 25^\circ\text{C}$. (Note 4)

SYMBOL	PARAMETER	CONDITIONS	MIN	TYP	MAX	UNITS
t_{SCK}	SCK Period	(Notes 11, 12)	●	10		ns
t_{SCKH}	SCK High Time		●	4		ns
t_{SCKL}	SCK Low Time		●	4		ns
t_{SSDISCK}	SDI Setup Time From SCK \uparrow	(Note 11)	●	4		ns
t_{HSDISCK}	SDI Hold Time From SCK \uparrow	(Note 11)	●	1		ns
t_{SCKCH}	SCK Period in Chain Mode	$t_{\text{SCKCH}} = t_{\text{SSDISCK}} + t_{\text{DSDO}}$ (Note 11)	●	13.5		ns
t_{DSDO}	SDO Data Valid Delay from SCK \uparrow	$C_L = 20\text{pF}$ (Note 11)	●		9.5	ns
t_{HSDO}	SDO Data Remains Valid Delay from SCK \uparrow	$C_L = 20\text{pF}$ (Note 10)	●	1		ns
$t_{\text{DSDOBUSYL}}$	SDO Data Valid Delay from BUSY \downarrow	$C_L = 20\text{pF}$ (Note 10)	●		5	ns
t_{EN}	Bus Enable Time After RDL \downarrow	(Note 11)	●		16	ns
t_{DIS}	Bus Relinquish Time After RDL \uparrow	(Note 11)	●		13	ns

Note 1: Stresses beyond those listed under Absolute Maximum Ratings may cause permanent damage to the device. Exposure to any Absolute Maximum Rating condition for extended periods may effect device reliability and lifetime.

Note 2: All voltage values are with respect to ground.

Note 3: When these pin voltages are taken below ground or above REF or OV_{DD} , they will be clamped by internal diodes. This product can handle input currents up to 100mA below ground or above REF or OV_{DD} without latch-up.

Note 4: $V_{\text{DD}} = 2.5\text{V}$, $OV_{\text{DD}} = 2.5\text{V}$, REF = 5V, $f_{\text{SAMPL}} = 250\text{kHz}$.

Note 5: Recommended operating conditions.

Note 6: Integral nonlinearity is defined as the deviation of a code from a straight line passing through the actual endpoints of the transfer curve. The deviation is measured from the center of the quantization band.

Note 7: Zero-scale error is the offset voltage measured from 0.5LSB when the output code flickers between 0000 0000 0000 0000 and 0000 0000 0000 0001. Full-scale error is the deviation of the last code transition from ideal and includes the effect of offset error.

Note 8: All specifications in dB are referred to a full-scale 5V input with a 5V reference voltage.

Note 9: $f_{\text{SAMPL}} = 250\text{kHz}$, I_{REF} varies proportionately with sample rate.

Note 10: Guaranteed by design, not subject to test.

Note 11: Parameter tested and guaranteed at $OV_{\text{DD}} = 1.71\text{V}$, $OV_{\text{DD}} = 2.5\text{V}$ and $OV_{\text{DD}} = 5.25\text{V}$.

Note 12: t_{SCK} of 10ns maximum allows a shift clock frequency up to 100MHz for rising capture.

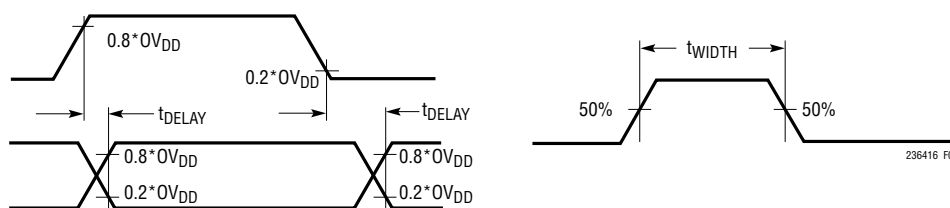
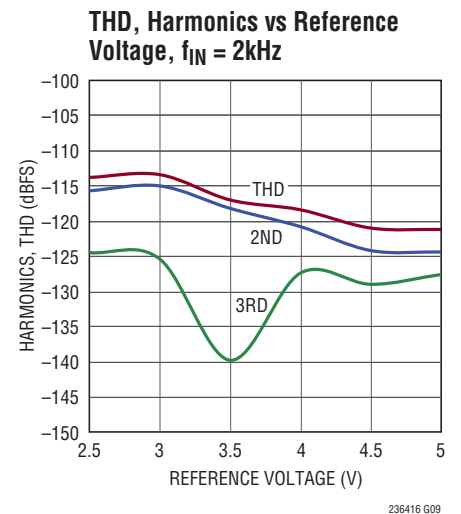
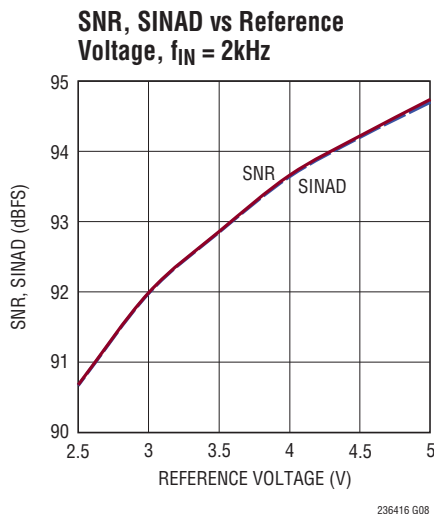
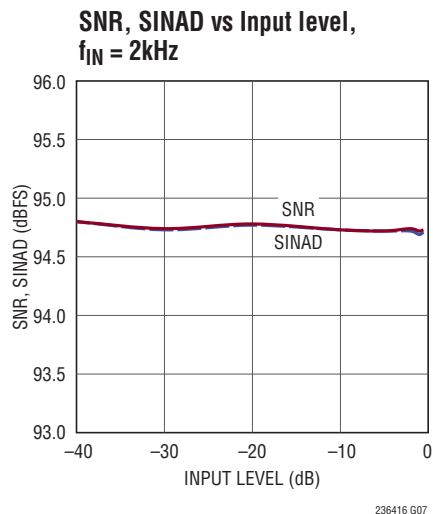
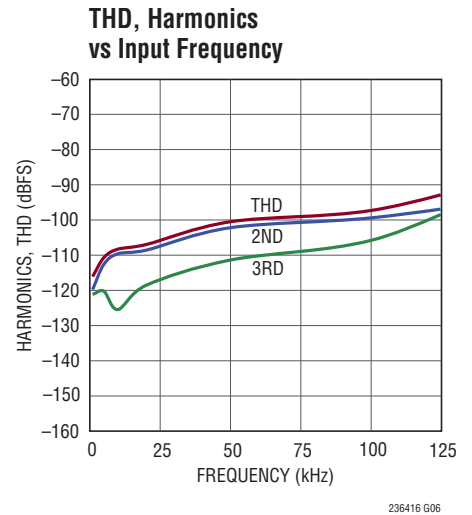
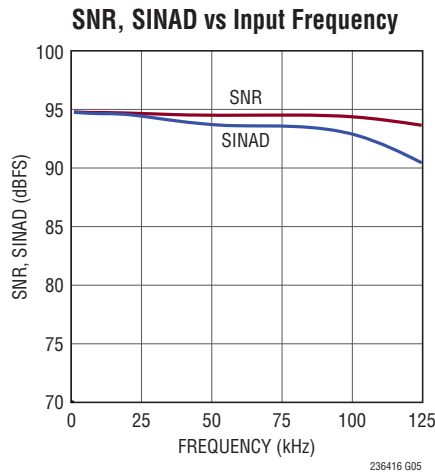
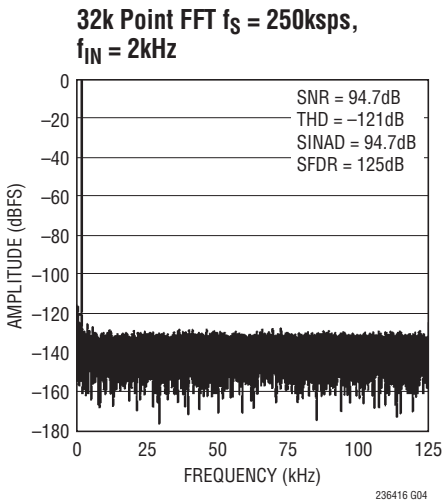
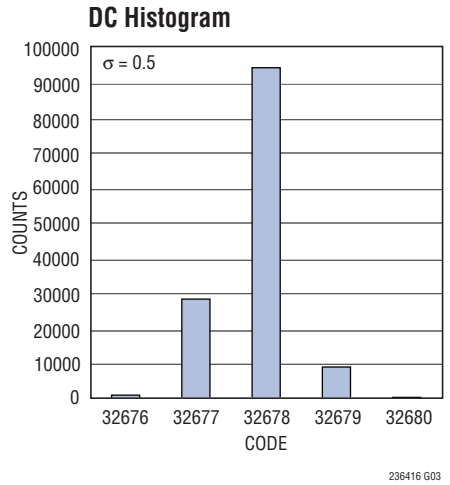
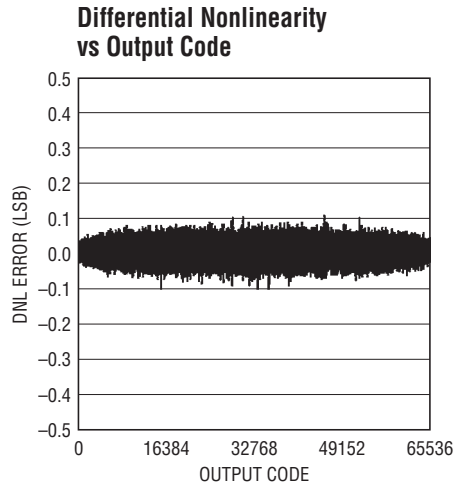
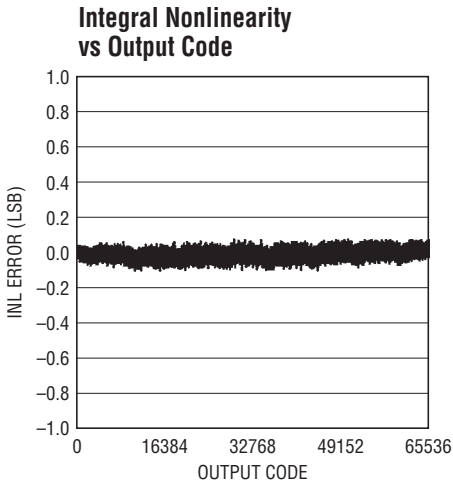

Figure 1. Voltage Levels for Timing Specifications

TYPICAL PERFORMANCE CHARACTERISTICS

$f_{SAMPL} = 250\text{kpsps}$, unless otherwise noted.

$T_A = 25^\circ\text{C}$, $V_{DD} = 2.5\text{V}$, $0V_{DD} = 2.5\text{V}$, $REF = 5\text{V}$,



TYPICAL PERFORMANCE CHARACTERISTICS $T_A = 25^\circ\text{C}$, $V_{DD} = 2.5\text{V}$, $I_{OVDD} = 2.5\text{V}$, $REF = 5\text{V}$, $f_{SAMPL} = 250\text{ksps}$, unless otherwise noted.

SNR, SINAD vs Temperature,
 $f_{IN} = 2\text{kHz}$

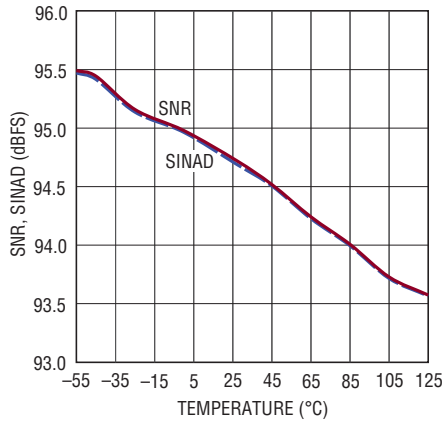

236416 G10

THD, Harmonics vs Temperature,
 $f_{IN} = 2\text{kHz}$

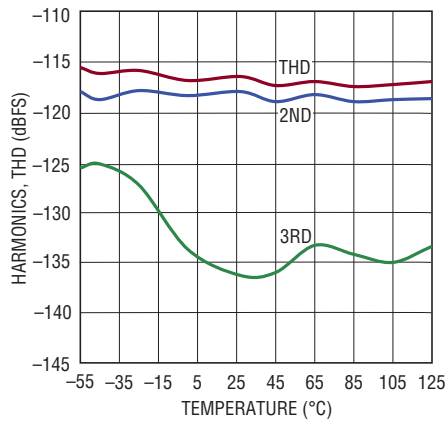

236416 G11

INL/DNL vs Temperature

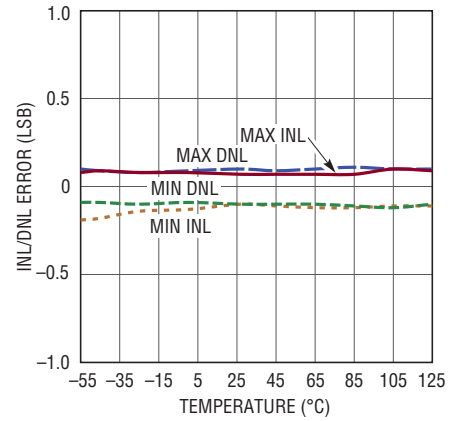

236416 G12

Full-Scale Error vs Temperature

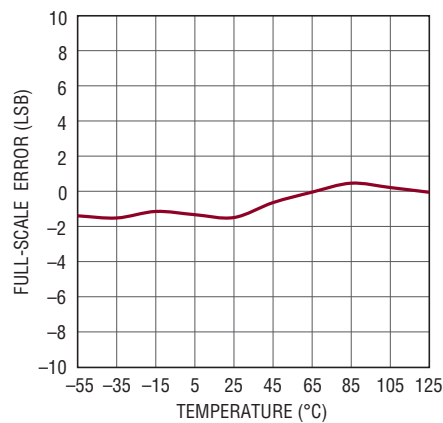

236416 G13

Offset Error vs Temperature

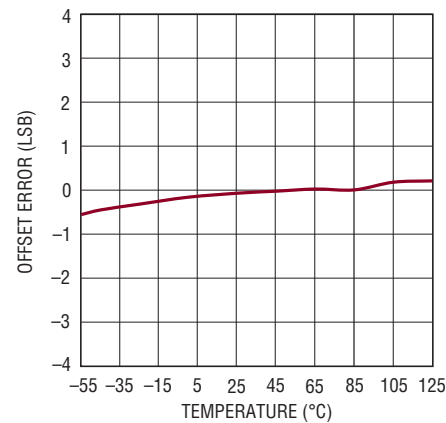

236416 G14

Supply Current vs Temperature

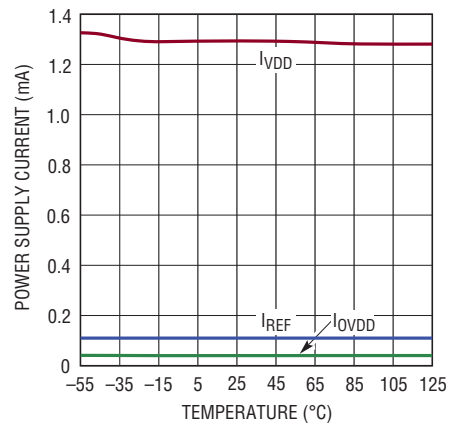

236416 G15

Shutdown Current vs Temperature

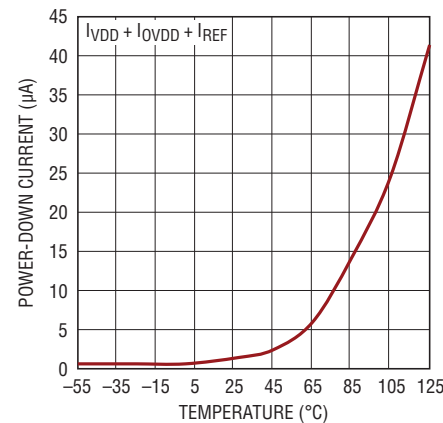

236416 G16

CMRR vs Input Frequency

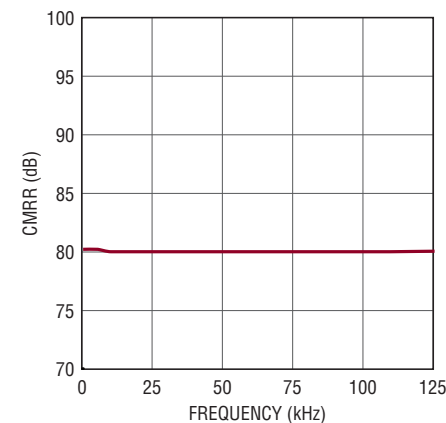

236416 G17

Reference Current vs Reference Voltage

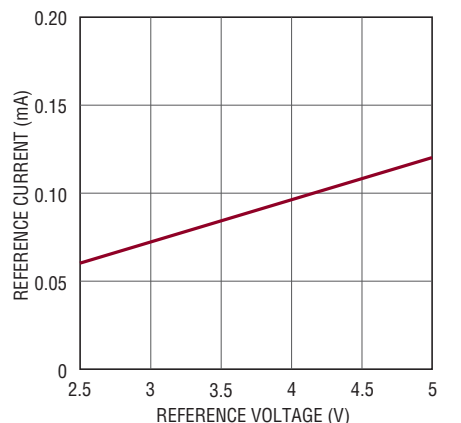

236416 G18

PIN FUNCTIONS

CHAIN (Pin 1): Chain Mode Selector Pin. When low, the LTC2364-16 operates in normal mode and the RDL/SDI input pin functions to enable or disable SDO. When high, the LTC2364-16 operates in chain mode and the RDL/SDI pin functions as SDI, the daisy-chain serial data input. Logic levels are determined by OV_{DD} .

V_{DD} (Pin 2): 2.5V Power Supply. The range of V_{DD} is 2.375V to 2.625V. Bypass V_{DD} to GND with a 10 μ F ceramic capacitor.

GND (Pins 3, 6, 10 and 16): Ground.

IN^+ (Pin 4): Analog Input. IN^+ operates differential with respect to IN^- with an $IN^+ - IN^-$ range of 0V to V_{REF} .

IN^- (Pin 5): Analog Ground Sense. IN^- has an input range of ± 100 mV with respect to GND and must be tied to the ground plane or a remote ground sense.

REF (Pins 7, 8): Reference Inputs. The range of REF is 2.5V to 5.1V. This pin is referred to the GND pin and should be decoupled closely to the pin with a 47 μ F ceramic capacitor (X5R, 0805 size).

CNV (Pin 9): Convert Input. A rising edge on this input powers up the part and initiates a new conversion. Logic levels are determined by OV_{DD} .

BUSY (Pin 11): BUSY Indicator. Goes high at the start of a new conversion and returns low when the conversion has finished. Logic levels are determined by OV_{DD} .

RDL/SDI (Pin 12): When CHAIN is low, the part is in normal mode and the pin is treated as a bus enabling input. When CHAIN is high, the part is in chain mode and the pin is treated as a serial data input pin where data from another ADC in the daisy chain is input. Logic levels are determined by OV_{DD} .

SCK (Pin 13): Serial Data Clock Input. When SDO is enabled, the conversion result or daisy-chain data from another ADC is shifted out on the rising edges of this clock MSB first. Logic levels are determined by OV_{DD} .

SDO (Pin 14): Serial Data Output. The conversion result or daisy-chain data is output on this pin on each rising edge of SCK MSB first. The output data is in straight binary format. Logic levels are determined by OV_{DD} .

OV_{DD} (Pin 15): I/O Interface Digital Power. The range of OV_{DD} is 1.71V to 5.25V. This supply is nominally set to the same supply as the host interface (1.8V, 2.5V, 3.3V, or 5V). Bypass OV_{DD} to GND with a 0.1 μ F capacitor.

GND (Exposed Pad Pin 17, DFN Package Only): Ground. Exposed pad must be soldered directly to the ground plane.

FUNCTIONAL BLOCK DIAGRAM

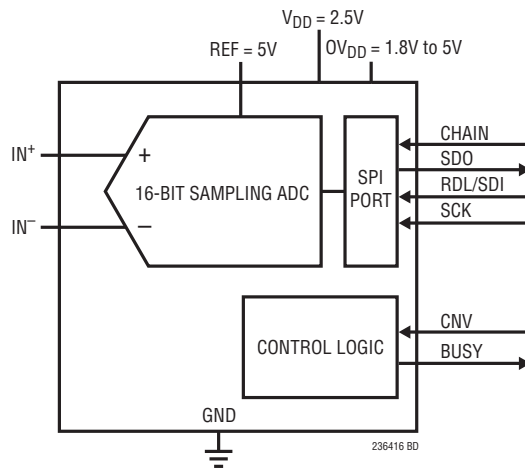

TIMING DIAGRAM

Conversion Timing Using the Serial Interface

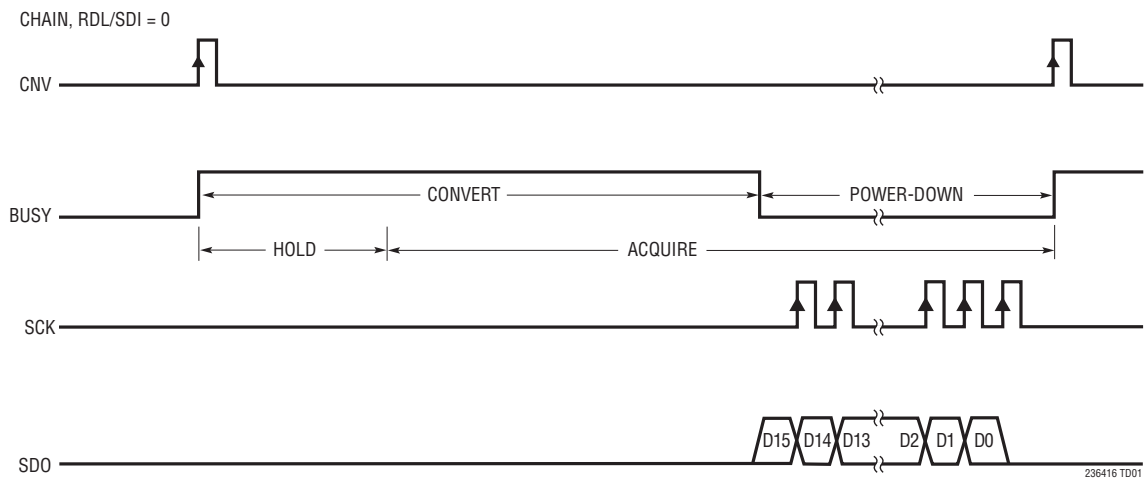

APPLICATIONS INFORMATION

OVERVIEW

The LTC2364-16 is a low noise, low power, high speed 16-bit successive approximation register (SAR) ADC. Operating from a single 2.5V supply, the LTC2364-16 supports a 0V to V_{REF} pseudo-differential unipolar input range with V_{REF} ranging from 2.5V to 5.1V, making it ideal for high performance applications which require a wide dynamic range. The LTC2364-16 achieves $\pm 0.75\text{LSB}$ INL max, no missing codes at 16 bits and 94.7dB SNR.

Fast 250ksps throughput with no cycle latency makes the LTC2364-16 ideally suited for a wide variety of high speed applications. An internal oscillator sets the conversion time, easing external timing considerations. The LTC2364-16 dissipates only 3.4mW at 250ksps, while an auto power-down feature is provided to further reduce power dissipation during inactive periods.

CONVERTER OPERATION

The LTC2364-16 operates in two phases. During the acquisition phase, the charge redistribution capacitor D/A converter (CDAC) is connected to the IN^+ and IN^- pins to sample the pseudo-differential analog input voltage. A rising edge on the CNV pin initiates a conversion. During the conversion phase, the 16-bit CDAC is sequenced through a successive approximation algorithm, effectively comparing the sampled input with binary-weighted fractions of the reference voltage (e.g. $V_{REF}/2$, $V_{REF}/4 \dots V_{REF}/65536$) using the differential comparator. At the end of conversion, the CDAC output approximates the sampled analog input. The ADC control logic then prepares the 16-bit digital output code for serial transfer.

TRANSFER FUNCTION

The LTC2364-16 digitizes the full-scale voltage of REF into 2^{16} levels, resulting in an LSB size of $76\mu\text{V}$ with $REF = 5\text{V}$. The ideal transfer function is shown in Figure 2. The output data is in straight binary format.

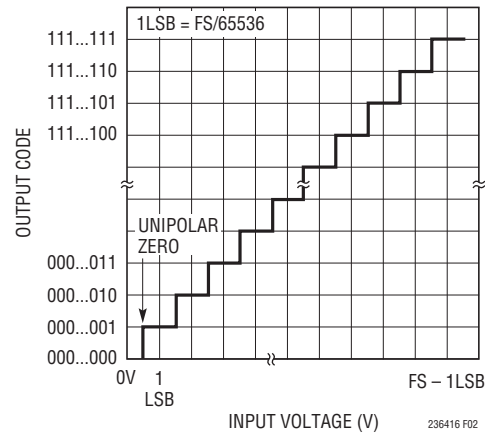

Figure 2. LTC2364-16 Transfer Function

ANALOG INPUT

The analog inputs of the LTC2364-16 are pseudo-differential in order to reduce any unwanted signal that is common to both inputs. The analog inputs can be modeled by the equivalent circuit shown in Figure 3. The diodes at the input provide ESD protection. In the acquisition phase, each input sees approximately 45pF (C_{IN}) from the sampling CDAC in series with 40Ω (R_{ON}) from the on-resistance of the sampling switch. The IN^+ input draws a current spike while charging the C_{IN} capacitor during acquisition. During conversion, the analog inputs draw only a small leakage current.

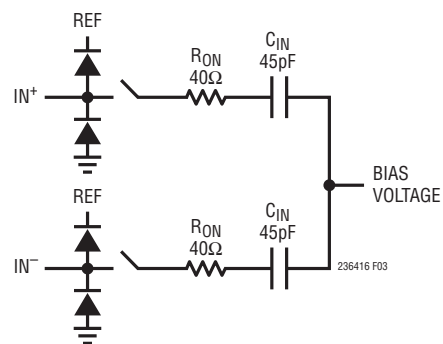

Figure 3. The Equivalent Circuit for the Differential Analog Input of the LTC2364-16

APPLICATIONS INFORMATION

INPUT DRIVE CIRCUITS

A low impedance source can directly drive the high impedance input of the LTC2364-16 without gain error. A high impedance source should be buffered to minimize settling time during acquisition and to optimize the distortion performance of the ADC. Minimizing settling time is important even for DC inputs, because the ADC input draws a current spike when entering acquisition.

For best performance, a buffer amplifier should be used to drive the analog input of the LTC2364-16. The amplifier provides low output impedance, which produces fast settling of the analog signal during the acquisition phase. It also provides isolation between the signal source and the current spike the ADC input draws.

Input Filtering

The noise and distortion of the buffer amplifier and signal source must be considered since they add to the ADC noise and distortion. Noisy input signals should be filtered prior to the buffer amplifier input with an appropriate filter to minimize noise. The simple 1-pole RC lowpass filter (LPF1) shown in Figure 4 is sufficient for many applications.

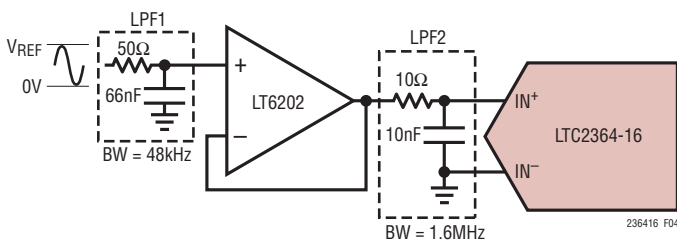

Figure 4. Input Signal Chain

Another filter network consisting of LPF2 should be used between the buffer and ADC input to both minimize the noise contribution of the buffer and to help minimize disturbances reflected into the buffer from sampling transients. Long RC time constants at the analog inputs will slow down the settling of the analog inputs. Therefore, LPF2 requires a wider bandwidth than LPF1. A buffer amplifier with a low noise density must be selected to minimize degradation of the SNR.

High quality capacitors and resistors should be used in the RC filters since these components can add distortion. NPO and silver mica type dielectric capacitors have excellent linearity. Carbon surface mount resistors can generate distortion from self heating and from damage that may occur during soldering. Metal film surface mount resistors are much less susceptible to both problems.

Pseudo-Differential Unipolar Inputs

For most applications, we recommend the low power LT6202 ADC driver to drive the LTC2364-16. With a low noise density of $1.9\text{nV}/\sqrt{\text{Hz}}$ and a low supply current of 3mA, the LT6202 is flexible and may be configured to convert signals of various amplitudes to the 0V to 5V input range of the LTC2364-16.

To achieve the full distortion performance of the LTC2364-16, a low distortion single-ended signal source driven through the LT6202 configured as a unity-gain buffer as shown in Figure 4 can be used to get the full data sheet THD specification of -120dB .

The LT6202 can also be used to buffer and convert large true bipolar signals which swing below ground to the 0V to 5V input range of the LTC2364-16. Figure 5a shows the LT6202 being used to convert a $\pm 10\text{V}$ true bipolar signal for use by the LTC2364-16. In this case, the LT6202 is configured as an inverting amplifier stage, which acts to attenuate and level shift the input signal to the 0V to 5V input range of the LTC2364-16. In the inverting configuration, the single-ended input signal source no longer directly drives a high impedance input. The input impedance is instead set by resistor R_{IN} . R_{IN} must be chosen carefully based on the source impedance of the signal source. Higher values of R_{IN} tend to degrade both the noise and distortion of the LT6202 and LTC2364-16 as a system. Table 1 shows the resulting SNR and THD for several values of R_{IN} , R_1 , R_2 , R_3 and R_4 in this configuration. Figure 5b shows the resulting FFT when using the LT6202 as shown in Figure 5a.

APPLICATIONS INFORMATION

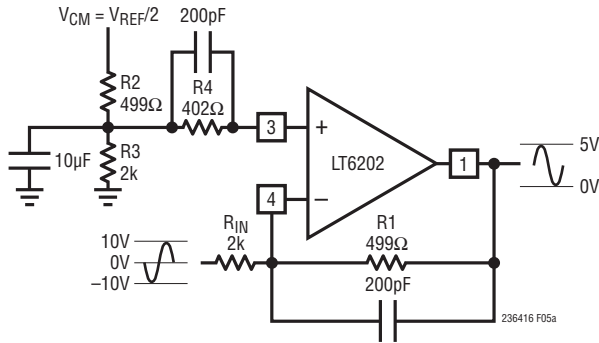

Figure 5a. LT6202 Converting a ±10V Bipolar Signal to a 0V to 5V Input Signal

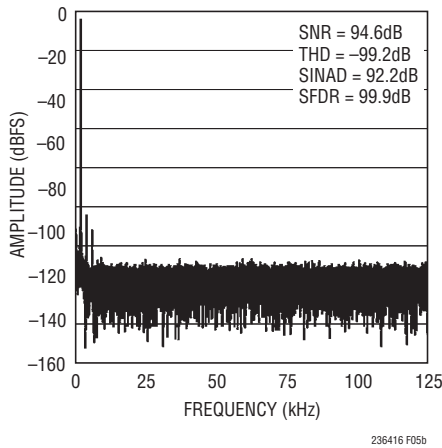

Figure 5b. 32k Point FFT Plot with $f_{IN} = 2\text{kHz}$ for Circuit Shown in Figure 5a

Table 1. SNR, THD vs R_{IN} for ±10V Input Signal

R_{IN} (Ω)	R1 (Ω)	R2 (Ω)	R3 (Ω)	R4 (Ω)	SNR (dB)	THD (dB)
2k	499	499	2k	402	94.6	-99.2
10k	2.49k	2.49k	10k	2k	94.4	-93.8
100k	24.9k	24.9k	100k	20k	92.4	-93.7

ADC REFERENCE

The LTC2364-16 requires an external reference to define its input range. A low noise, low temperature drift reference is critical to achieving the full data sheet performance of the ADC. Linear Technology offers a portfolio of high performance references designed to meet the needs of many applications. With its small size, low power and high accuracy, the LTC6655-5 is particularly well suited for use with the LTC2364-16. The LTC6655-5 offers 0.025% (max) initial accuracy and 2ppm/°C (max) temperature coefficient for high precision applications. The LTC6655-5 is fully specified over the H-grade temperature range and complements the extended temperature operation of the LTC2364-16 up to 125°C. We recommend bypassing the LTC6655-5 with a 47μF ceramic capacitor (X5R, 0805 size) close to the REF pin.

The REF pin of the LTC2364-16 draws charge (Q_{CONV}) from the 47μF bypass capacitor during each conversion cycle. The reference replenishes this charge with a DC current, $I_{REF} = Q_{CONV}/t_{CYC}$. The DC current draw of the REF pin, I_{REF} , depends on the sampling rate and output code. If the LTC2364-16 is used to continuously sample a signal at a constant rate, the LTC6655-5 will keep the deviation of the reference voltage over the entire code span to less than 0.5LSBs.

When idling, the REF pin on the LTC2364-16 draws only a small leakage current (< 1μA). In applications where a burst of samples is taken after idling for long periods as shown in Figure 6, I_{REF} quickly goes from approximately 0μA to a maximum of 0.2mA at 250ksps. This step in DC current draw triggers a transient response in the reference that must be considered since any deviation in the reference output voltage will affect the accuracy of the output

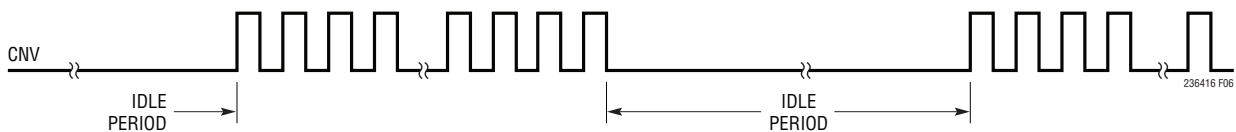

Figure 6. CNV Waveform Showing Burst Sampling

APPLICATIONS INFORMATION

code. In applications where the transient response of the reference is important, the fast settling LTC6655-5 reference is also recommended.

In applications where power management is critical and the external reference may be powered down, it is recommended that REF is kept greater than 2V in order to guarantee a maximum shutdown current of 140 μ A. In such applications, a Schottky diode can be placed between REF and V_{DD}, as shown in Figure 7.

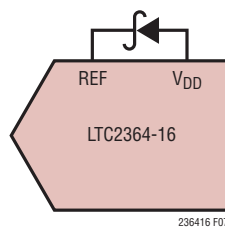

Figure 7. A Schottky Diode Between REF and V_{DD} Maintains REF > 2V for Applications Where the Reference May Be Powered Down

DYNAMIC PERFORMANCE

Fast Fourier Transform (FFT) techniques are used to test the ADC's frequency response, distortion and noise at the rated throughput. By applying a low distortion sine wave and analyzing the digital output using an FFT algorithm, the ADC's spectral content can be examined for frequencies outside the fundamental. The LTC2364-16 provides guaranteed tested limits for both AC distortion and noise measurements.

Signal-to-Noise and Distortion Ratio (SINAD)

The signal-to-noise and distortion ratio (SINAD) is the ratio between the RMS amplitude of the fundamental input frequency and the RMS amplitude of all other frequency components at the A/D output. The output is band-limited to frequencies from above DC and below half the sampling frequency. Figure 8 shows that the LTC2364-16 achieves a typical SINAD of 94.7dB at a 250kHz sampling rate with a 2kHz input.

Signal-to-Noise Ratio (SNR)

The signal-to-noise ratio (SNR) is the ratio between the RMS amplitude of the fundamental input frequency and

the RMS amplitude of all other frequency components except the first five harmonics and DC. Figure 8 shows that the LTC2364-16 achieves a typical SNR of 94.7dB at a 250kHz sampling rate with a 2kHz input.

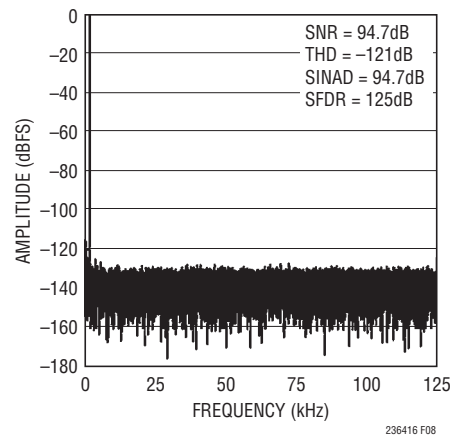

Figure 8. 32k Point FFT with $f_{IN} = 2$ kHz of the LTC2364-16

Total Harmonic Distortion (THD)

Total Harmonic Distortion (THD) is the ratio of the RMS sum of all harmonics of the input signal to the fundamental itself. The out-of-band harmonics alias into the frequency band between DC and half the sampling frequency ($f_{SAMPL}/2$). THD is expressed as:

$$THD = 20 \log \frac{\sqrt{V_2^2 + V_3^2 + V_4^2 + \dots + V_N^2}}{V_1}$$

where V₁ is the RMS amplitude of the fundamental frequency and V₂ through V_N are the amplitudes of the second through Nth harmonics.

POWER CONSIDERATIONS

The LTC2364-16 provides two power supply pins: the 2.5V power supply (V_{DD}), and the digital input/output interface power supply (OV_{DD}). The flexible OV_{DD} supply allows the LTC2364-16 to communicate with any digital logic operating between 1.8V and 5V, including 2.5V and 3.3V systems.

Power Supply Sequencing

The LTC2364-16 does not have any specific power supply sequencing requirements. Care should be taken to adhere

236416fa

APPLICATIONS INFORMATION

to the maximum voltage relationships described in the Absolute Maximum Ratings section. The LTC2364-16 has a power-on-reset (POR) circuit that will reset the LTC2364-16 at initial power-up or whenever the power supply voltage drops below 1V. Once the supply voltage re-enters the nominal supply voltage range, the POR will reinitialize the ADC. No conversions should be initiated until 20 μ s after a POR event to ensure the reinitialization period has ended. Any conversions initiated before this time will produce invalid results.

TIMING AND CONTROL

CNV Timing

The LTC2364-16 conversion is controlled by CNV. A rising edge on CNV will start a conversion and power up the LTC2364-16. Once a conversion has been initiated, it cannot be restarted until the conversion is complete. For optimum performance, CNV should be driven by a clean low jitter signal. Converter status is indicated by the BUSY output which remains high while the conversion is in progress. To ensure that no errors occur in the digitized results, any additional transitions on CNV should occur within 40ns from the start of the conversion or after the conversion has been completed. Once the conversion has completed, the LTC2364-16 powers down and begins acquiring the input signal.

Acquisition

A proprietary sampling architecture allows the LTC2364-16 to begin acquiring the input signal for the next conversion 527ns after the start of the current conversion. This extends the acquisition time to 3.460 μ s, easing settling requirements and allowing the use of extremely low power ADC drivers. (Refer to the Timing Diagram.)

Internal Conversion Clock

The LTC2364-16 has an internal clock that is trimmed to achieve a maximum conversion time of 3 μ s.

Auto Power-Down

The LTC2364-16 automatically powers down after a conversion has been completed and powers up once a

new conversion is initiated on the rising edge of CNV. During power down, data from the last conversion can be clocked out. To minimize power dissipation during power down, disable SDO and turn off SCK. The auto power-down feature will reduce the power dissipation of the LTC2364-16 as the sampling frequency is reduced. Since power is consumed only during a conversion, the LTC2364-16 remains powered down for a larger fraction of the conversion cycle (t_{CYC}) at lower sample rates, thereby reducing the average power dissipation which scales with the sampling rate as shown in Figure 9.

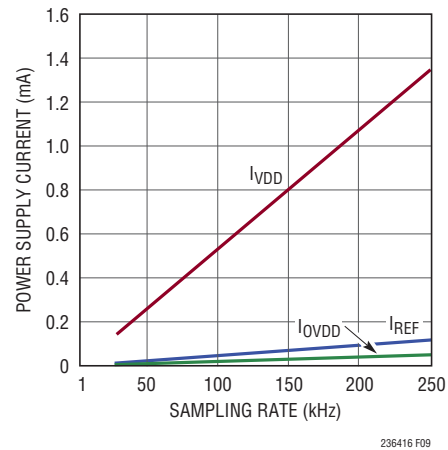

Figure 9. Power Supply Current of the LTC2364-16 Versus Sampling Rate

DIGITAL INTERFACE

The LTC2364-16 has a serial digital interface. The flexible OV_{DD} supply allows the LTC2364-16 to communicate with any digital logic operating between 1.8V and 5V, including 2.5V and 3.3V systems.

The serial output data is clocked out on the SDO pin when an external clock is applied to the SCK pin if SDO is enabled. Clocking out the data after the conversion will yield the best performance. With a shift clock frequency of at least 20MHz, a 250ksps throughput is still achieved. The serial output data changes state on the rising edge of SCK and can be captured on the falling edge or next rising edge of SCK. D15 remains valid till the first rising edge of SCK.

The serial interface on the LTC2364-16 is simple and straightforward to use. The following sections describe the operation of the LTC2364-16. Several modes are provided

236416fa

TIMING DIAGRAMS

depending on whether a single or multiple ADCs share the SPI bus or are daisy chained.

Normal Mode, Single Device

When CHAIN = 0, the LTC2364-16 operates in normal mode. In normal mode, RDL/SDI enables or disables the serial data output pin SDO. If RDL/SDI is high, SDO is in high impedance. If RDL/SDI is low, SDO is driven.

Figure 10 shows a single LTC2364-16 operated in normal mode with CHAIN and RDL/SDI tied to ground. With RDL/SDI grounded, SDO is enabled and the MSB(D15) of the new conversion data is available at the falling edge of BUSY. This is the simplest way to operate the LTC2364-16.

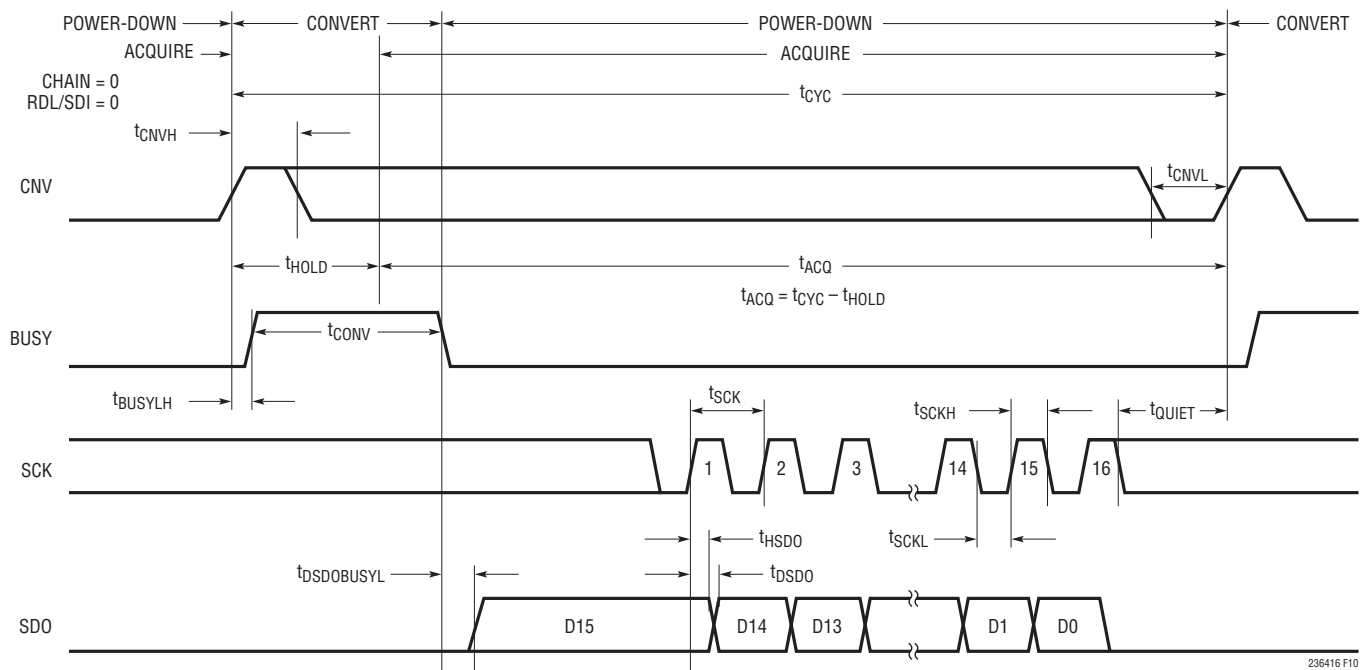
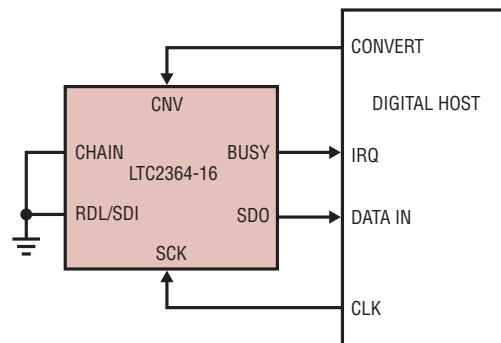

Figure 10. Using a Single LTC2364-16 in Normal Mode

TIMING DIAGRAMS

Normal Mode, Multiple Devices

Figure 11 shows multiple LTC2364-16 devices operating in normal mode (CHAIN = 0) sharing CNV, SCK and SDO. By sharing CNV, SCK and SDO, the number of required signals to operate multiple ADCs in parallel is reduced. Since SDO is shared, the RDL/SDI input of each ADC must

be used to allow only one LTC2364-16 to drive SDO at a time in order to avoid bus conflicts. As shown in Figure 11, the RDL/SDI inputs idle high and are individually brought low to read data out of each device between conversions. When RDL/SDI is brought low, the MSB of the selected device is output onto SDO.

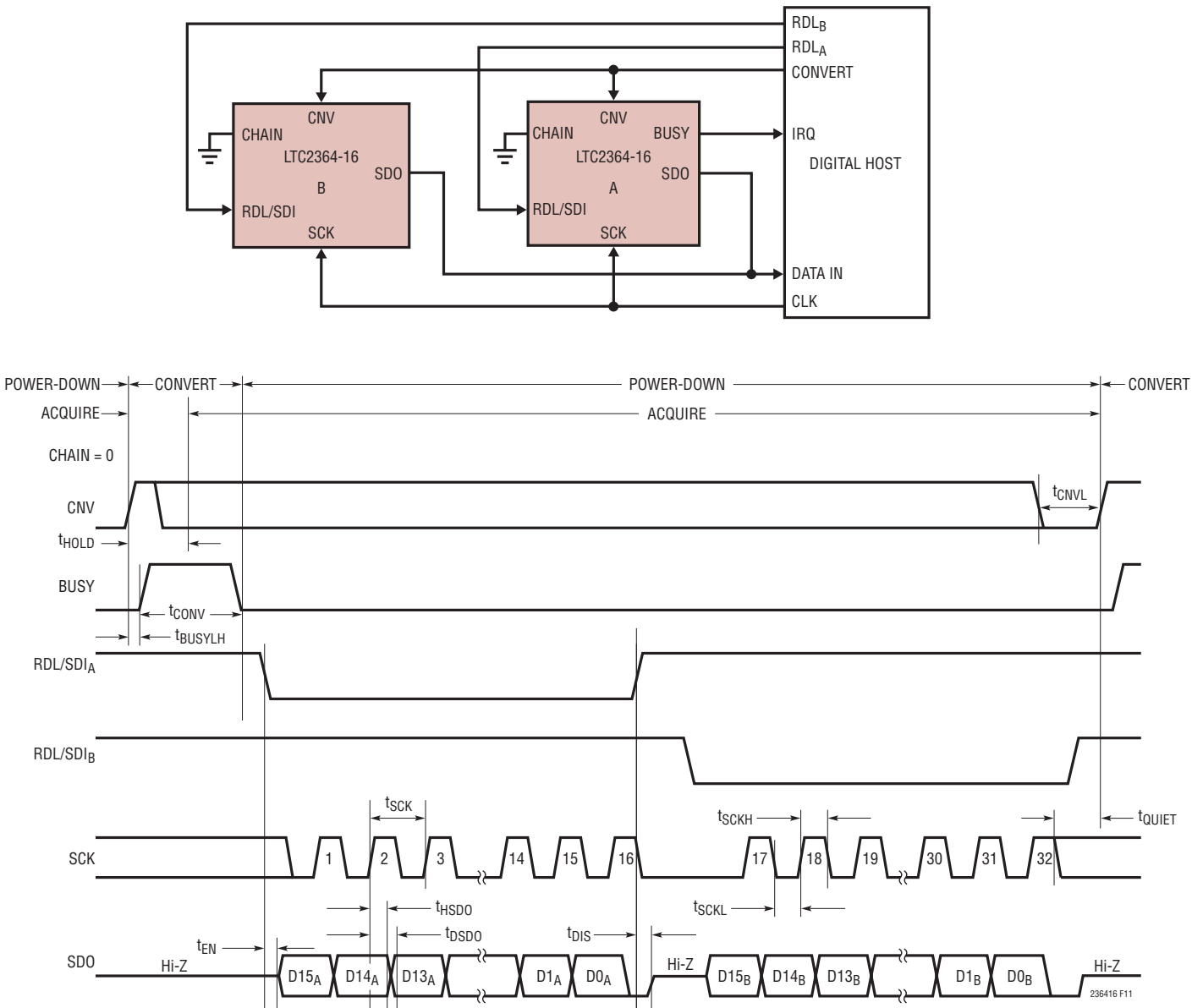

Figure 11. Normal Mode With Multiple Devices Sharing CNV, SCK and SDO

TIMING DIAGRAMS

Chain Mode, Multiple Devices

When CHAIN = OV_{DD} , the LTC2364-16 operates in chain mode. In chain mode, SDO is always enabled and RDL/SDI serves as the serial data input pin (SDI) where daisy-chain data output from another ADC can be input.

This is useful for applications where hardware constraints may limit the number of lines needed to interface to a large

number of converters. Figure 12 shows an example with two daisy-chained devices. The MSB of converter A will appear at SDO of converter B after 16 SCK cycles. The MSB of converter A is clocked in at the SDI/RDL pin of converter B on the rising edge of the first SCK.

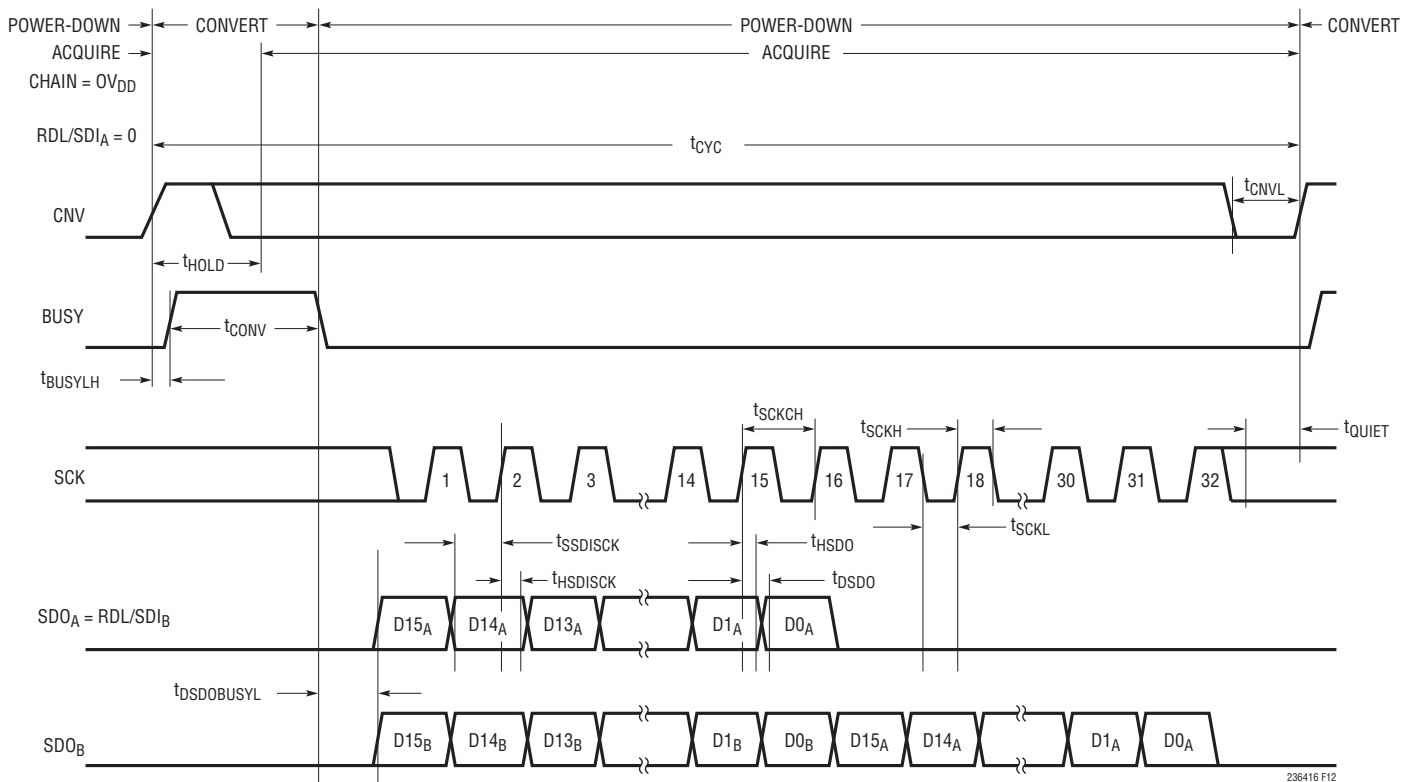
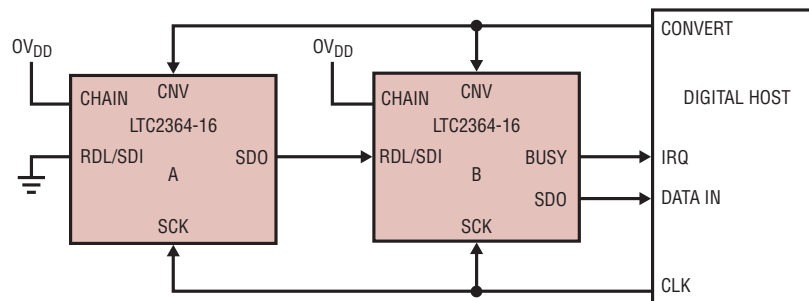

Figure 12. Chain Mode Timing Diagram

BOARD LAYOUT

To obtain the best performance from the LTC2364-16 a printed circuit board is recommended. Layout for the printed circuit board (PCB) should ensure the digital and analog signal lines are separated as much as possible. In particular, care should be taken not to run any digital clocks or signals alongside analog signals or underneath the ADC.

Recommended Layout

The following is an example of a recommended PCB layout. A single solid ground plane is used. Bypass capacitors to the supplies are placed as close as possible to the supply pins. Low impedance common returns for these bypass capacitors are essential to the low noise operation of the ADC. The analog input traces are screened by ground. For more details and information refer to DC1813A, the evaluation kit for the LTC2364-16.

Partial Top Silkscreen

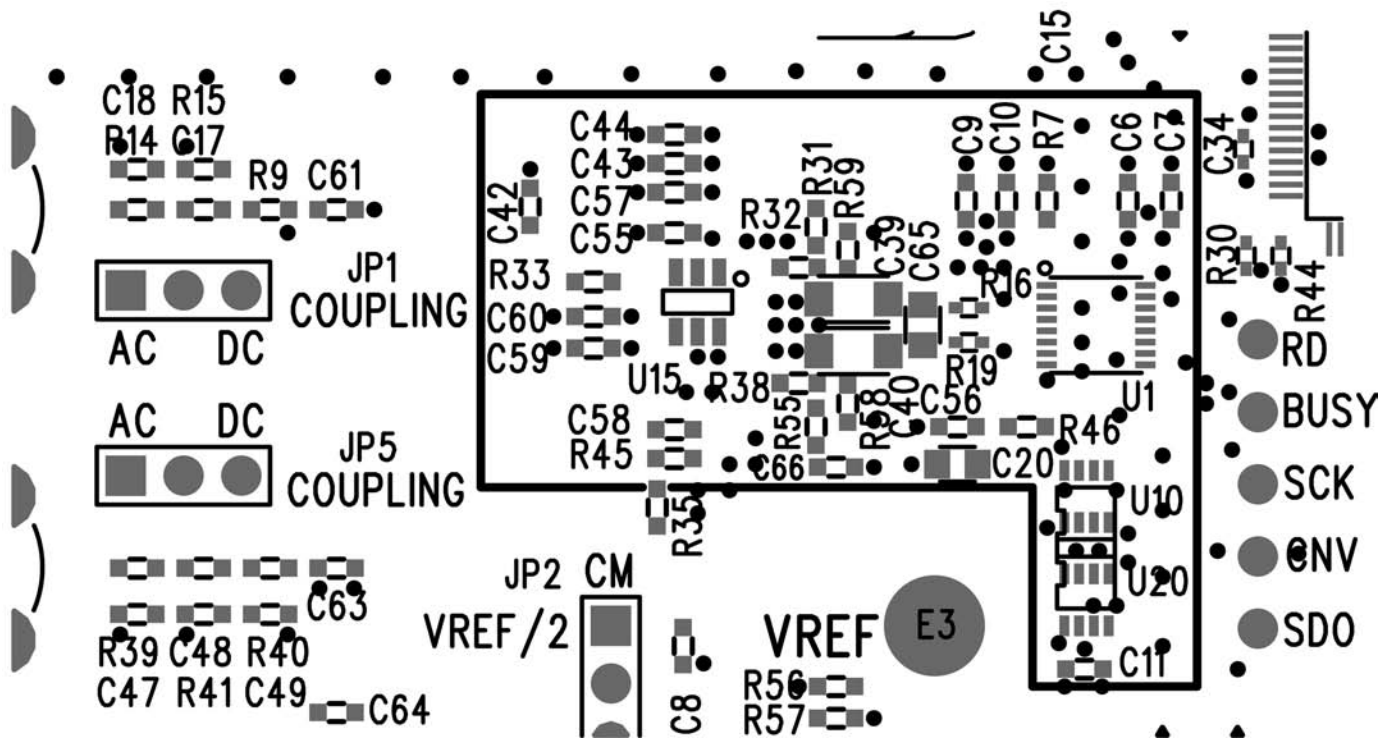

BOARD LAYOUT

Partial Layer 1 Component Side

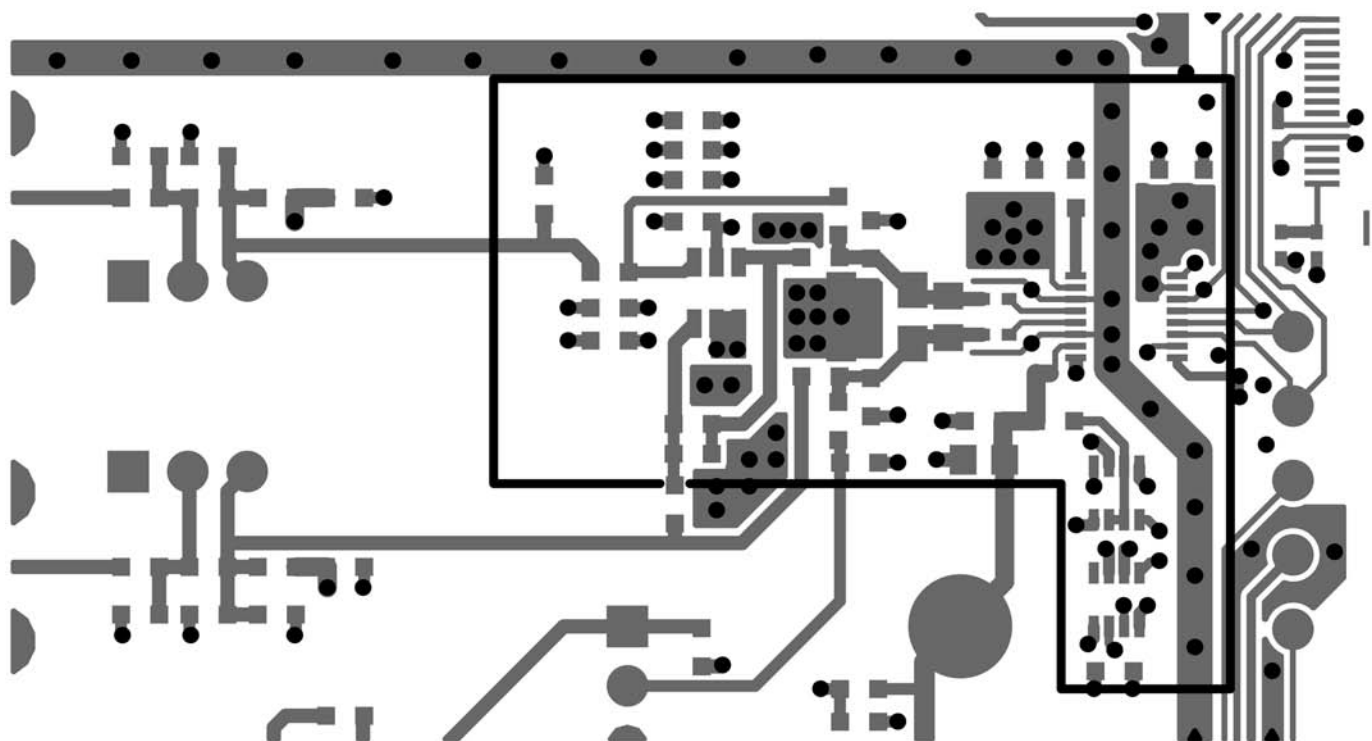

Partial Layer 2 Ground Plane

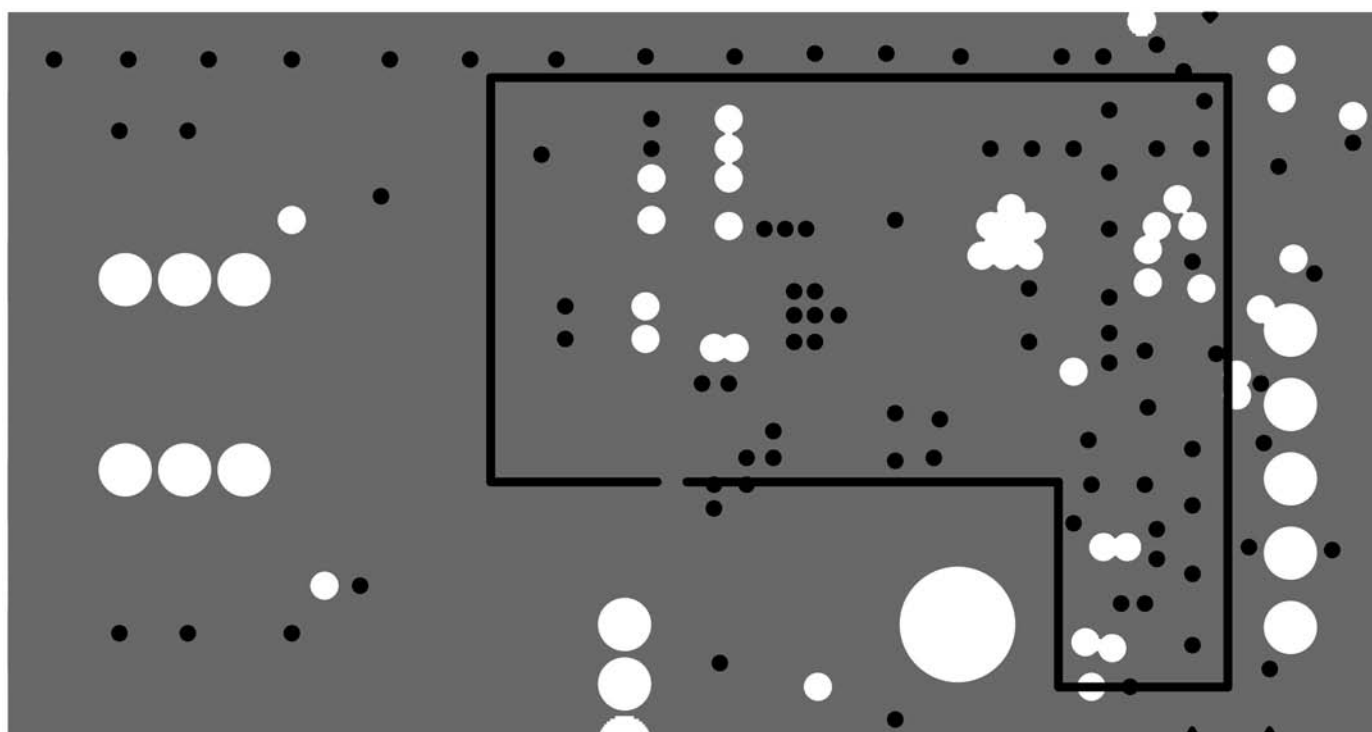

236416fa

BOARD LAYOUT

Partial Layer 3 PWR Plane

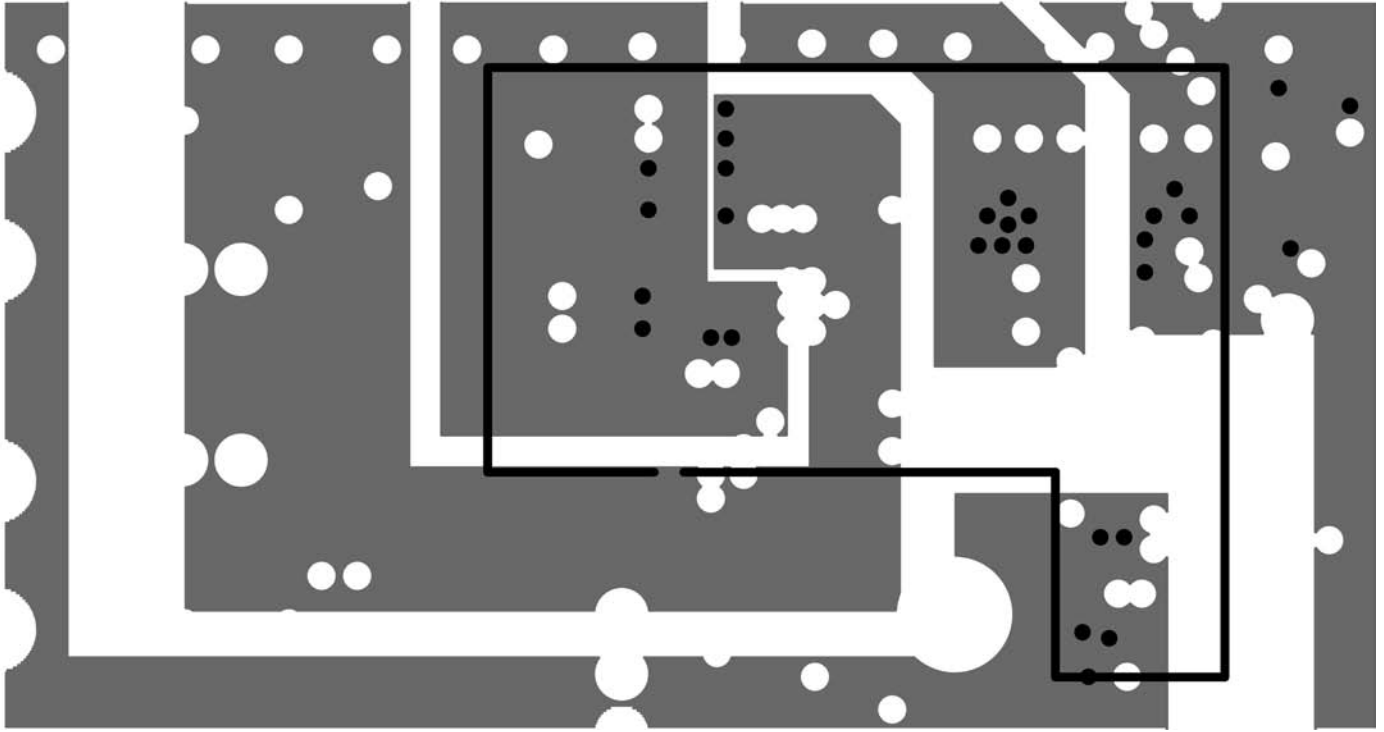

Partial Layer 4 Bottom Layer

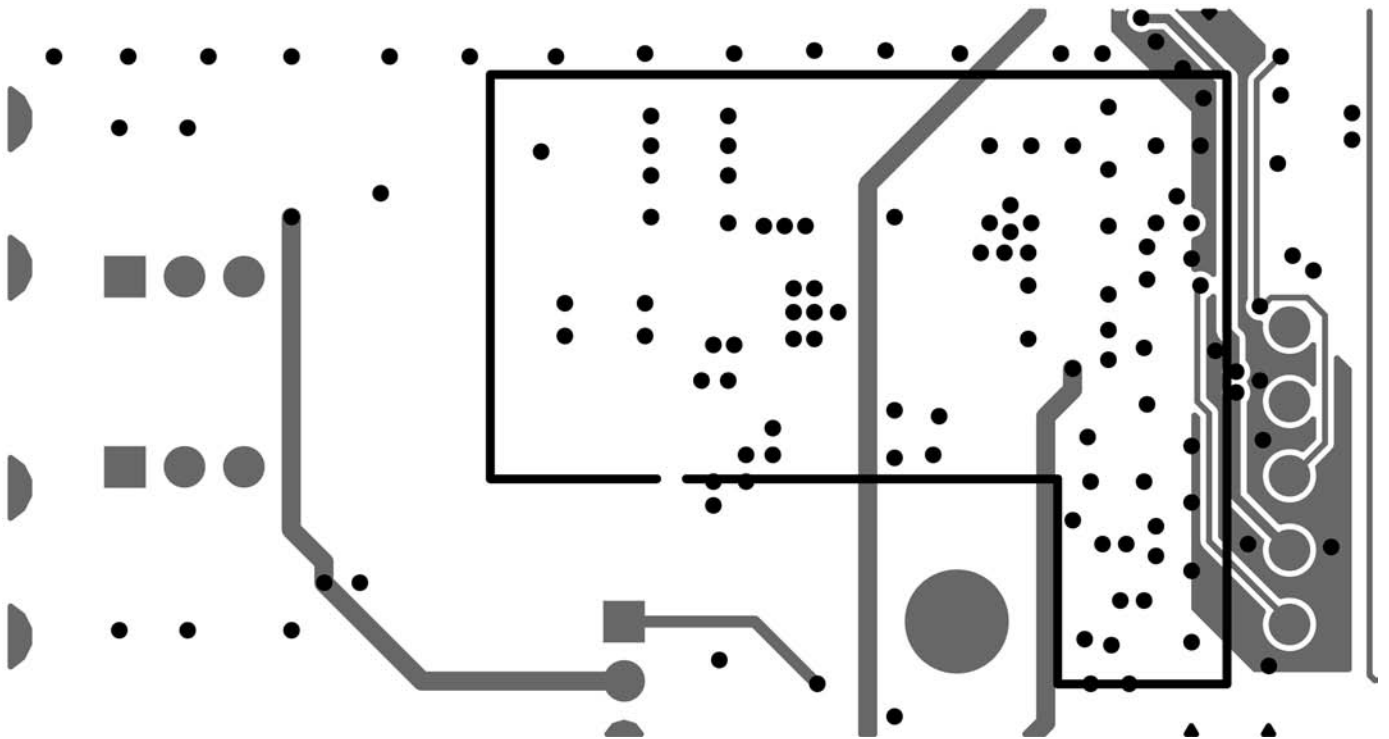

236416fa

BOARD LAYOUT

Partial Schematic of Demoboard

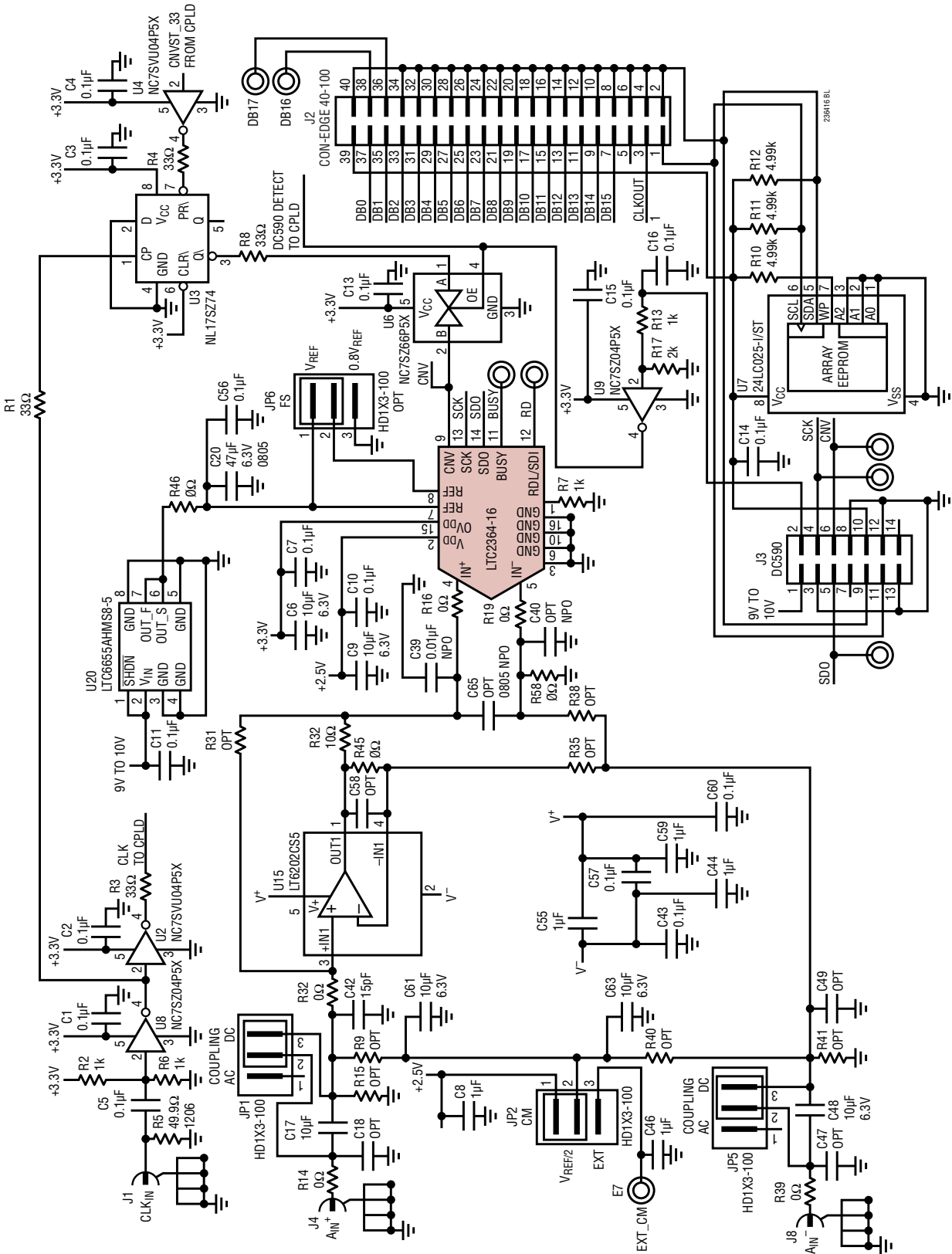

236416fa

PACKAGE DESCRIPTION

Please refer to <http://www.linear.com/designtools/packaging/> for the most recent package drawings.

MS Package 16-Lead Plastic MSOP (Reference LTC DWG # 05-08-1669 Rev 0)

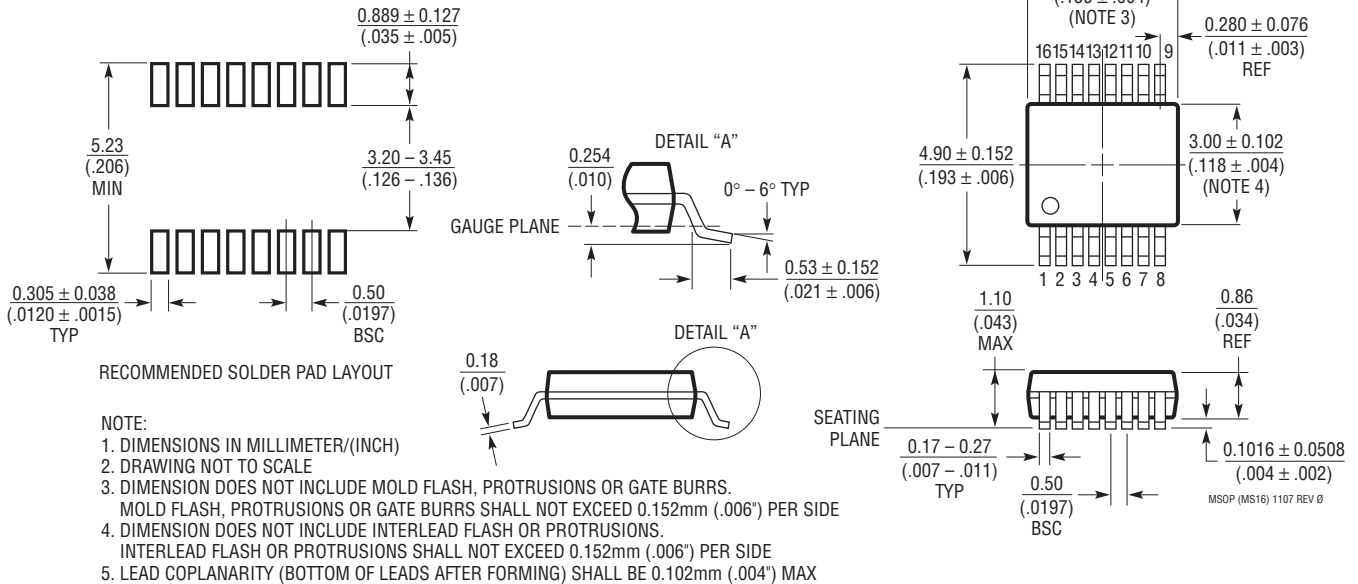

DE Package 16-Lead Plastic DFN (4mm × 3mm) (Reference LTC DWG # 05-08-1732 Rev 0)

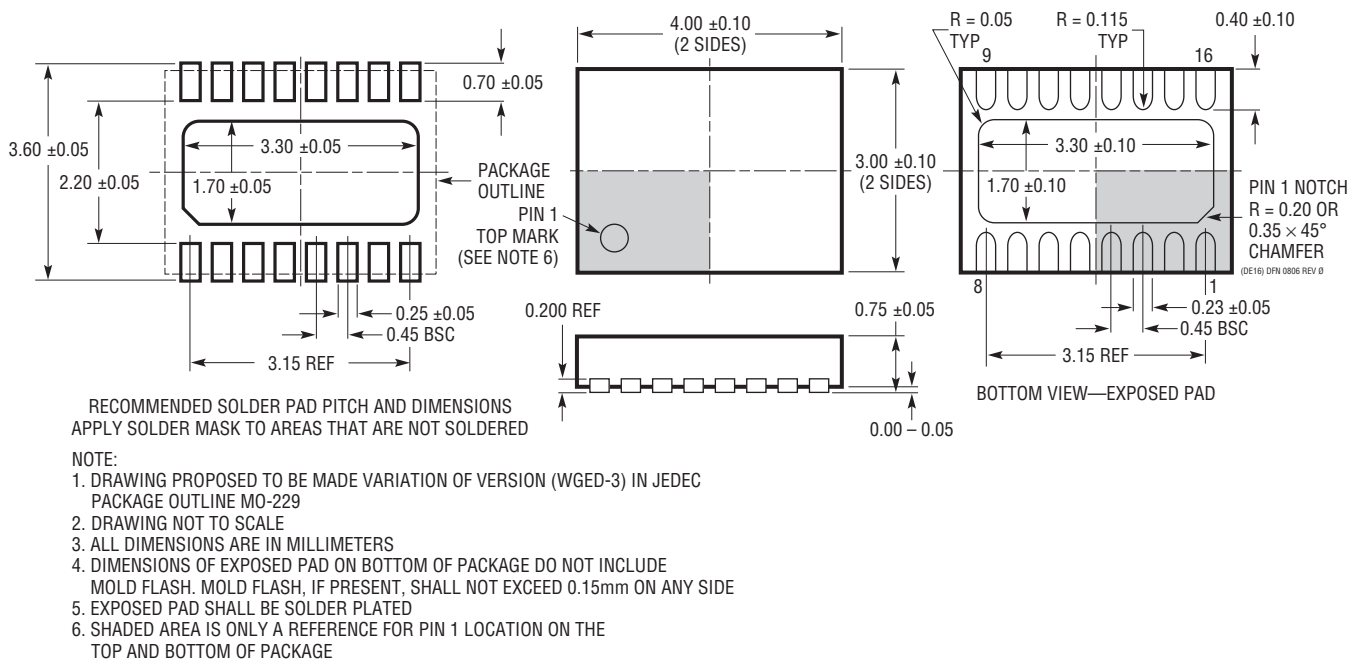

REVISION HISTORY

REV	DATE	DESCRIPTION	PAGE NUMBER
A	08/12	Corrected resolution from 18-bit to 16-bit in Description section	1

TYPICAL APPLICATION

LT6202 Converting a ±10V Bipolar Signal to a 0V to 5V Input Signal Into the LTC2364-16

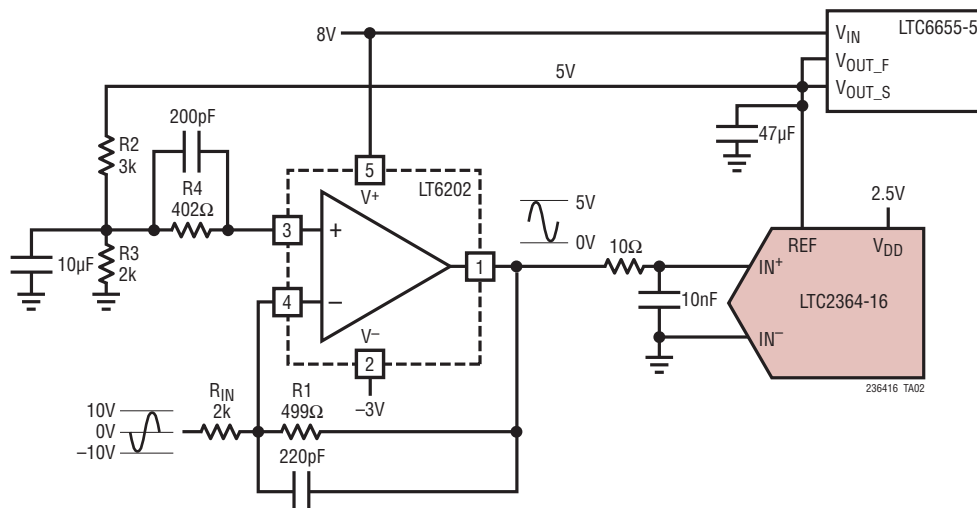

RELATED PARTS

PART NUMBER	DESCRIPTION	COMMENTS
ADCs		
LTC2379-18/LTC2378-18 LTC2377-18/LTC2376-18	18-Bit, 1.6Msps/1Msps/500ksps/250ksps Serial, Low Power ADC	2.5V Supply, Differential Input, 101.2dB SNR, ±5V Input Range, DGC, Pin-Compatible Family in MSOP-16 and 4mm × 3mm DFN-16 Packages
LTC2380-16/LTC2378-16 LTC2377-16/LTC2376-16	16-Bit, 2Msps/1Msps/500ksps/250ksps Serial, Low Power ADC	2.5V Supply, Differential Input, 96.2dB SNR, ±5V Input Range, DGC, Pin-Compatible Family in MSOP-16 and 4mm × 3mm DFN-16 Packages
LTC2383-16/LTC2382-16/LTC2381-16	16-Bit, 1Msps/500ksps/250ksps Serial, Low Power ADC	2.5V Supply, Differential Input, 92dB SNR, ±2.5V Input Range, Pin-Compatible Family in MSOP-16 and 4mm × 3mm DFN-16 Packages
LTC2393-16/LTC2392-16/LTC2391-16	16-Bit, 1Msps/500ksps/250ksps Parallel/Serial ADC	5V Supply, Differential Input, 94dB SNR, ±4.096V Input Range, Pin-Compatible Family in 7mm × 7mm LQFP-48 and QFN-48 Packages
LTC1864/LTC1864L	16-Bit, 250ksps/150ksps 1-Channel μPower ADC	5V/3V Supply, 1-Channel, 4.3mW/1.5mW, MSOP-8 Package
LTC1865/LTC1865L	16-Bit, 250ksps/150ksps 2-Channel μPower ADC	5V/3V Supply, 2-Channel, 4.3mW/1.3mW, MSOP-10 Package
DACS		
LTC2757	18-Bit, Single Parallel I _{OUT} SoftSpan™ DAC	±1LSB INL/DNL, Software-Selectable Ranges, 7mm × 7mm LQFP-48 Package
LTC2641	16-Bit/14-Bit/12-Bit Single Serial V _{OUT} DACs	±1LSB INL/DNL, MSOP-8, 3mm × 3mm DFN, SO-8 Packages, 0V to 5V Output
LTC2630	12-Bit/10-Bit/8-Bit Single V _{OUT} DACs	SC70 6-Pin Package, Internal Reference, ±1LSB INL (12 Bits)
References		
LTC6655	Precision Low Drift Low Noise Buffered Reference	5V/2.5V, 2ppm/°C, 0.25ppm Peak-to-Peak Noise, MSOP-8 Package
LTC6652	Precision Low Drift Low Noise Buffered Reference	5V/2.5V, 5ppm/°C, 2.1ppm Peak-to-Peak Noise, MSOP-8 Package
Amplifiers		
LT6202/LT6203	Single/Dual 100MHz Rail-to-Rail Input/Output Noise Low Power Amplifiers	1.9nV/√Hz, 3mA Maximum, 100MHz Gain Bandwidth
LT6200/LT6200-5/ LT6200-10	165MHz/800MHz/1.6GHz Op Amp with Unity Gain/AV = 5/AV = 10	Low Noise Voltage: 0.95nV/√Hz (100kHz), Low Distortion: -80dB at 1MHz, TSOT23-6, SO-8 Packages

Looking for pricing, stock, or lifecycle information?

Click below to explore more details on WIN SOURCE:

 [View LTC2364CMS-16#PBF on WIN SOURCE](#)

 [Linear Technology](#) Information

Optimize Your Supply Chain with WIN SOURCE Solutions

-  Global Sourcing Solution
-  Obsolete Management
-  Cost Control Management
-  Shortage Management
-  Alternative Solution
-  Excess Inventory Management