



**THE DATASHEET OF
LTC2323CUFD-16#TRPBF**



Dual, 16-Bit, 5MSPS Differential Input ADC with Wide Input Common Mode Range

FEATURES

- 5MSPS Throughput Rate
- ± 4 LSB INL (Typ)
- Guaranteed 16-Bit, No Missing Codes
- 8V_{P-P} Differential Inputs with Wide Input Common Mode Range
- 81dB SNR (Typ) at $f_{IN} = 2$ MHz
- -85dB THD (Typ) at $f_{IN} = 2$ MHz
- Guaranteed Operation to 125°C
- Single 3.3V or 5V Supply
- Low Drift (20ppm/°C Max) 2.048V or 4.096V Internal Reference
- 1.8V to 2.5V I/O Voltages
- CMOS or LVDS SPI-Compatible Serial I/O
- Power Dissipation 40mW/Ch (Typ)
- Small 28-Lead (4mm × 5mm) QFN Package

APPLICATIONS

- High Speed Data Acquisition Systems
- Communications
- Remote Data Acquisition
- Imaging
- Optical Networking
- Automotive
- Multiphase Motor Control

DESCRIPTION

The LTC[®]2323-16 is a low noise, high speed dual 16-bit successive approximation register (SAR) ADC with differential inputs and wide input common mode range. Operating from a single 3.3V or 5V supply, the LTC2323-16 has an 8V_{P-P} differential input range, making it ideal for applications which require a wide dynamic range with high common mode rejection. The LTC2323-16 achieves ± 4 LSB INL typical, no missing codes at 16 bits and 81dB SNR.

The LTC2323-16 has an onboard low drift (20ppm/°C max) 2.048V or 4.096V temperature-compensated reference. The LTC2323-16 also has a high speed SPI-compatible serial interface that supports CMOS or LVDS. The fast 5MSPS per channel throughput with one-cycle latency makes the LTC2323-16 ideally suited for a wide variety of high speed applications. The LTC2323-16 dissipates only 40mW per channel and offers nap and sleep modes to reduce the power consumption to 5 μ W for further power savings during inactive periods.

LT, LT, LTC, LTM, Linear Technology and the Linear Logo are registered trademarks of Analog Devices, Inc. All other trademarks are the property of their respective owners.

TYPICAL APPLICATION

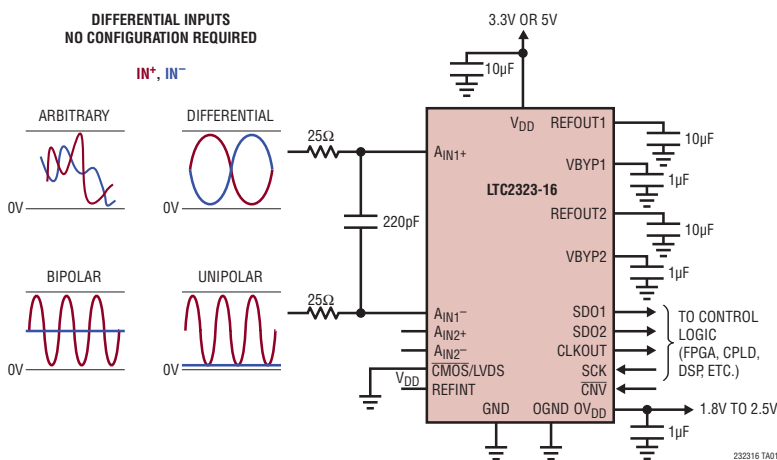

32k Point FFT $f_S = 5$ MSPS, $f_{IN} = 2.2$ MHz

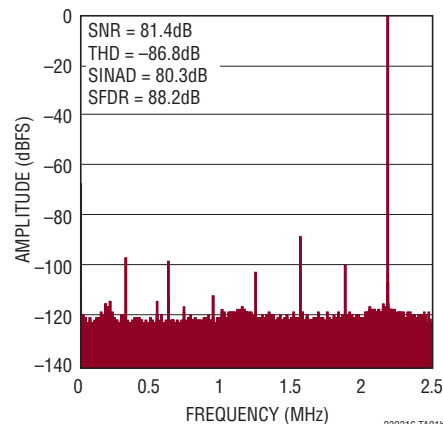

LTC2323-16

ABSOLUTE MAXIMUM RATINGS

(Notes 1, 2)

Supply Voltage (V_{DD})	6V
Supply Voltage (OV_{DD})	3V
Supply Bypass Voltage (V_{BYP1} , V_{BYP2})	3V
Analog Input Voltage	
A_{IN+} , A_{IN-} (Note 3)	-0.3V to ($V_{DD} + 0.3V$)
REFOUT1,2	-0.3V to ($V_{DD} + 0.3V$)
CNV (Note 15)	-0.3V to ($V_{DD} + 0.3V$)
Digital Input Voltage	
(Note 3)	(GND - 0.3V) to ($OV_{DD} + 0.3V$)
Digital Output Voltage	
(Note 3)	(GND - 0.3V) to ($OV_{DD} + 0.3V$)
Power Dissipation	200mW
Operating Temperature Range	
LTC2323C	0°C to 70°C
LTC2323I	-40°C to 85°C
LTC2323H	-40°C to 125°C
Storage Temperature Range	-65°C to 150°C

PIN CONFIGURATION

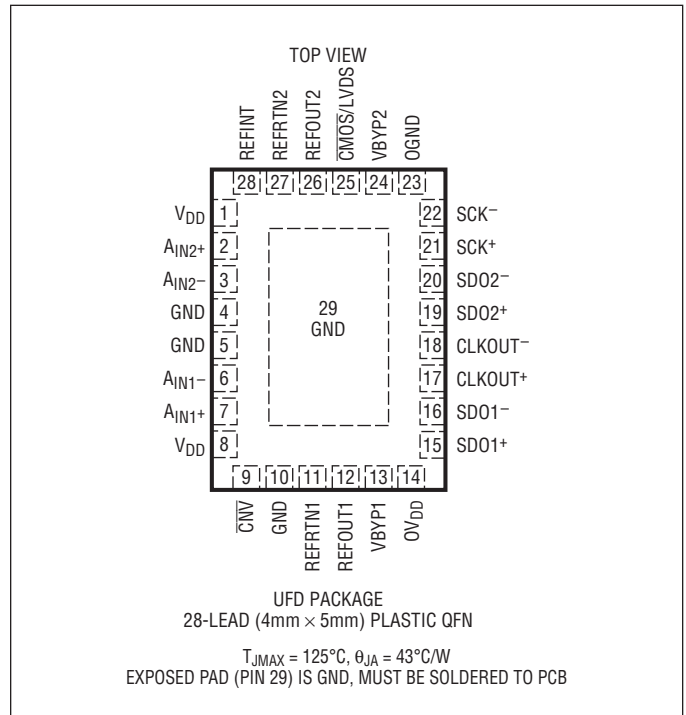

ORDER INFORMATION <http://www.linear.com/product/LTC2323-16#orderinfo>

LEAD FREE FINISH	TAPE AND REEL	PART MARKING*	PACKAGE DESCRIPTION	TEMPERATURE RANGE
LTC2323CUFD-16#PBF	LTC2323CUFD-16#TRPBF	23236	28-Lead (4mm × 5mm) Plastic QFN	0°C to 70°C
LTC2323IUFD-16#PBF	LTC2323IUFD-16#TRPBF	23236	28-Lead (4mm × 5mm) Plastic QFN	-40°C to 85°C
LTC2323HUFD-16#PBF	LTC2323HUFD-16#TRPBF	23236	28-Lead (4mm × 5mm) Plastic QFN	-40°C to 125°C

Consult LTC Marketing for parts specified with wider operating temperature ranges. *The temperature grade is identified by a label on the shipping container.

For more information on lead free part marking, go to: <http://www.linear.com/leadfree/>

For more information on tape and reel specifications, go to: <http://www.linear.com/tapeandreeel/>. Some packages are available in 500 unit reels through designated sales channels with #TRMPBF suffix.

ELECTRICAL CHARACTERISTICS

The ● denotes the specifications which apply over the full operating temperature range, otherwise specifications are at $T_A = 25^{\circ}C$ (Note 4).

SYMBOL	PARAMETER	CONDITIONS	MIN	TYP	MAX	UNITS
V_{IN+}	Absolute Input Range (A_{IN1+} , A_{IN2+})	(Note 5)	●	0	V_{DD}	V
V_{IN-}	Absolute Input Range (A_{IN1-} , A_{IN2-})	(Note 5)	●	0	V_{DD}	V
$V_{IN+} - V_{IN-}$	Input Differential Voltage Range	$V_{IN} = V_{IN+} - V_{IN-}$	●	-REFOUT1,2	REFOUT1,2	V
V_{CM}	Common Mode Input Range	$V_{IN} = (V_{IN+} + V_{IN-})/2$	●	0	V_{DD}	V
I_{IN}	Analog Input DC Leakage Current		●	-1	1	μA
C_{IN}	Analog Input Capacitance			10		pF
CMRR	Input Common Mode Rejection Ratio	$f_{IN} = 2.2MHz$		85		dB
I_{REFOUT}	External Reference Current	REFINT = 0V, REFOUT = 4.096V		675		μA

232316fc

CONVERTER CHARACTERISTICS

The ● denotes the specifications which apply over the full operating temperature range, otherwise specifications are at $T_A = 25^\circ\text{C}$ (Note 4).

SYMBOL	PARAMETER	CONDITIONS	MIN	TYP	MAX	UNITS	
	Resolution		●	16		Bits	
	No Missing Codes		●	16		Bits	
	Transition Noise			1.5		LSB_{RMS}	
INL	Integral Linearity Error	(Note 6)	●	-12	±4	12	LSB
DNL	Differential Linearity Error		●	-0.99	±0.4	0.99	LSB
BZE	Bipolar Zero-Scale Error	(Note 7)	●	-12	0	12	LSB
	Bipolar Zero-Scale Error Drift			0.01			$\text{LSB}/^\circ\text{C}$
FSE	Bipolar Full-Scale Error	$V_{\text{REFOUT}1,2} = 4.096\text{V}$ (REFINT Grounded) (Note 7)	●	-90	±10	90	LSB
	Bipolar Full-Scale Error Drift	$V_{\text{REFOUT}1,2} = 4.096\text{V}$ (REFINT Grounded)		15			$\text{ppm}/^\circ\text{C}$

DYNAMIC ACCURACY

The ● denotes the specifications which apply over the full operating temperature range, otherwise specifications are at $T_A = 25^\circ\text{C}$ and $A_{\text{IN}} = -1\text{dBFS}$ (Notes 4, 8).

SYMBOL	PARAMETER	CONDITIONS	MIN	TYP	MAX	UNITS	
SINAD	Signal-to-(Noise + Distortion) Ratio	$f_{\text{IN}} = 2.2\text{MHz}$, $V_{\text{REFOUT}1,2} = 4.096\text{V}$, Internal Reference	●	76	80		dB
		$f_{\text{IN}} = 2.2\text{MHz}$, $V_{\text{REFOUT}1,2} = 5\text{V}$, External Reference			80		dB
SNR	Signal-to-Noise Ratio	$f_{\text{IN}} = 2.2\text{MHz}$, $V_{\text{REFOUT}1,2} = 4.096\text{V}$, Internal Reference	●	76.5	81		dB
		$f_{\text{IN}} = 2.2\text{MHz}$, $V_{\text{REFOUT}1,2} = 5\text{V}$, External Reference			81.7		dB
THD	Total Harmonic Distortion	$f_{\text{IN}} = 2.2\text{MHz}$, $V_{\text{REFOUT}1,2} = 4.096\text{V}$, Internal Reference	●		-87	-80	dB
		$f_{\text{IN}} = 2.2\text{MHz}$, $V_{\text{REFOUT}1,2} = 5\text{V}$, External Reference			-88		dB
SFDR	Spurious Free Dynamic Range	$f_{\text{IN}} = 2.2\text{MHz}$, $V_{\text{REFOUT}1,2} = 4.096\text{V}$, Internal Reference	●	78	91		dB
		$f_{\text{IN}} = 2.2\text{MHz}$, $V_{\text{REFOUT}1,2} = 5\text{V}$, External Reference			88		dB
	-3dB Input Linear Bandwidth			10		MHz	
	Aperture Delay			500		ps	
	Aperture Delay Matching			500		ps	
	Aperture Jitter			1		ps_{RMS}	
	Transient Response	Full-Scale Step		3		ns	

INTERNAL REFERENCE CHARACTERISTICS

The ● denotes the specifications which apply over the full operating temperature range, otherwise specifications are at $T_A = 25^\circ\text{C}$ (Note 4).

SYMBOL	PARAMETER	CONDITIONS	MIN	TYP	MAX	UNITS	
$V_{\text{REFOUT}1,2}$	Internal Reference Output Voltage	$4.75\text{V} < V_{\text{DD}} < 5.25\text{V}$	●	4.088	4.096	4.106	V
		$3.13\text{V} < V_{\text{DD}} < 3.47\text{V}$	●	2.044	2.048	2.053	
	V_{REFIN} Temperature Coefficient	(Note 14)	●	3	20	$\text{ppm}/^\circ\text{C}$	
	REFOUT1,2 Output Impedance			0.25		Ω	
	$V_{\text{REFOUT}1,2}$ Line Regulation	$V_{\text{DD}} = 4.75\text{V}$ to 5.25V		0.3		mV/V	

DIGITAL INPUTS AND DIGITAL OUTPUTS

The ● denotes the specifications which apply over the full operating temperature range, otherwise specifications are at $T_A = 25^\circ\text{C}$ (Note 4).

SYMBOL	PARAMETER	CONDITIONS		MIN	TYP	MAX	UNITS
V_{IH}	High Level Input Voltage		●	$0.8 \cdot OV_{DD}$			V
V_{IL}	Low Level Input Voltage		●			$0.2 \cdot OV_{DD}$	V
I_{IN}	Digital Input Current	$V_{IN} = 0V$ to OV_{DD}	●	-10		10	μA
C_{IN}	Digital Input Capacitance				5		pF
V_{OH}	High Level Output Voltage	$I_O = -500\mu\text{A}$	●	$OV_{DD} - 0.2$			V
V_{OL}	Low Level Output Voltage	$I_O = 500\mu\text{A}$	●			0.2	V
I_{OZ}	Hi-Z Output Leakage Current	$V_{OUT} = 0V$ to OV_{DD}	●	-10		10	μA
I_{SOURCE}	Output Source Current	$V_{OUT} = 0V$			-10		mA
I_{SINK}	Output Sink Current	$V_{OUT} = OV_{DD}$			10		mA
V_{ID}	LVDS Differential Input Voltage	100 Ω Differential Termination, $OV_{DD} = 2.5V$	●	240		600	mV
V_{IS}	LVDS Common Mode Input Voltage	100 Ω Differential Termination, $OV_{DD} = 2.5V$	●	1		1.45	V
V_{OD}	LVDS Differential Output Voltage	100 Ω Differential Load, LVDS Mode, $OV_{DD} = 2.5V$	●	100	150	300	mV
V_{OS}	LVDS Common Mode Output Voltage	100 Ω Differential Load, LVDS Mode, $OV_{DD} = 2.5V$	●	0.85	1.2	1.4	V
V_{OD_LP}	Low Power LVDS Differential Output Voltage	100 Ω Differential Load, Low Power, LVDS Mode, $OV_{DD} = 2.5V$	●	75	100	250	mV
V_{OS_LP}	Low Power LVDS Common Mode Output Voltage	100 Ω Differential Load, Low Power, LVDS Mode, $OV_{DD} = 2.5V$	●	0.9	1.2	1.4	V

POWER REQUIREMENTS

The ● denotes the specifications which apply over the full operating temperature range, otherwise specifications are at $T_A = 25^\circ\text{C}$ (Note 4).

SYMBOL	PARAMETER	CONDITIONS		MIN	TYP	MAX	UNITS
V_{DD}	Supply Voltage	5V Operation	●	4.75		5.25	V
		3.3V Operation	●	3.13		3.47	V
OV_{DD}	Supply Voltage		●	1.71		2.63	V
I_{VDD}	Supply Current	5Msps Sample Rate ($IN^+ = IN^- = 0V$)	●		14.5	18	mA
I_{OVDD}	Supply Current	5Msps Sample Rate ($C_L = 5pF$) CMOS Mode	●		4	5	mA
		5Msps Sample Rate ($R_L = 100\Omega$) LVDS Mode	●		8	12	mA
I_{NAP}	Nap Mode Current	Conversion Done (I_{VDD})	●		3	5	mA
I_{SLEEP}	Sleep Mode Current	Sleep Mode ($I_{VDD} + I_{OVDD}$) CMOS Mode	●		1	5	μA
		Sleep Mode ($I_{VDD} + I_{OVDD}$) LVDS Mode	●		1	5	μA
$P_{D_3.3V}$	Power Dissipation	$V_{DD} = 3.3V$ 5Msps Sample Rate ($IN^+ = IN^- = 0V$) CMOS Mode	●		55	58	mW
		$V_{DD} = 3.3V$ 5Msps Sample Rate ($IN^+ = IN^- = 0V$) LVDS Mode	●		65	86	mW
	Nap Mode	$V_{DD} = 3.3V$ Conversion Done ($I_{VDD} + I_{OVDD}$) CMOS Mode	●		10	13	mW
		$V_{DD} = 3.3V$ Conversion Done ($I_{VDD} + I_{OVDD}$) LVDS Mode	●		31	41	mW
P_{D_5V}	Power Dissipation	$V_{DD} = 5V$ 5Msps Sample Rate ($IN^+ = IN^- = 0V$) CMOS Mode	●		80	100	mW
		$V_{DD} = 5V$ 5Msps Sample Rate ($IN^+ = IN^- = 0V$) LVDS Mode	●		95	110	mW
	Nap Mode	$V_{DD} = 5V$ Conversion Done ($I_{VDD} + I_{OVDD}$) CMOS Mode	●		15	25	mW
		$V_{DD} = 5V$ Conversion Done ($I_{VDD} + I_{OVDD}$) LVDS Mode	●		31	40	mW
	Sleep Mode	$V_{DD} = 5V$ Sleep Mode ($I_{VDD} + I_{OVDD}$) CMOS Mode	●		5	25	μW
		$V_{DD} = 5V$ Sleep Mode ($I_{VDD} + I_{OVDD}$) LVDS Mode	●		5	25	μW

ADC TIMING CHARACTERISTICS

The ● denotes the specifications which apply over the full operating temperature range, otherwise specifications are at $T_A = 25^\circ\text{C}$ (Note 4).

SYMBOL	PARAMETER	CONDITIONS	MIN	TYP	MAX	UNITS
f_{SMPL}	Maximum Sampling Frequency		●		5	Msps
t_{CYC}	Time Between Conversions	(Note 11)	●	200	1000000	ns
t_{ACQ}	Acquisition Time	(Note 11)	●	28.5		ns
t_{CONV}	Conversion Time		●	171.5		ns
t_{CNVH}	$\overline{\text{CNV}}$ High Time		●	25		ns
t_{DCNVSCKL}	SCK Quiet Time from $\overline{\text{CNV}}\downarrow$	(Note 11)	●	9.5		ns
$t_{\text{DSCKL CNVH}}$	SCK Delay Time from $\overline{\text{CNV}}\downarrow$	(Note 11)	●	19.1		ns
t_{SCK}	SCK Period	(Notes 12, 13)	●	9.4		ns
t_{SCKH}	SCK High Time		●	4		ns
t_{SCKL}	SCK Low Time		●	4		ns
$t_{\text{DSCKCLKOUT}}$	SCK to CLKOUT Delay	(Note 12)	●	3		ns
$t_{\text{DCLKOUTSDOV}}$	SDO Data Valid Delay from $\text{CLKOUT}\downarrow$	$C_L = 5\text{pF}$ (Note 12)	●		2	ns
t_{HSDO}	SDO Data Remains Valid Delay from $\text{CLKOUT}\downarrow$	$C_L = 5\text{pF}$ (Note 11)	●		2	ns
t_{DCNVSDOV}	SDO Data Valid Delay from $\overline{\text{CNV}}\downarrow$	$C_L = 5\text{pF}$ (Note 11)	●	2.5	3	ns
t_{DCNVSDOZ}	Bus Relinquish Time After $\overline{\text{CNV}}\uparrow$	(Note 11)	●		3	ns
t_{WAKE}	REFOUT1,2 Wakeup Time	$C_{\text{REFOUT1,2}} = 10\mu\text{F}$		10		ms

Note 1: Stresses beyond those listed under Absolute Maximum Ratings may cause permanent damage to the device. Exposure to any Absolute Maximum Rating condition for extended periods may affect device reliability and lifetime.

Note 2: All voltage values are with respect to ground.

Note 3: When these pin voltages are taken below ground, or above V_{DD} or OV_{DD} , they will be clamped by internal diodes. This product can handle input currents up to 100mA below ground, or above V_{DD} or OV_{DD} , without latch-up.

Note 4: $V_{\text{DD}} = 5\text{V}$, $\text{OV}_{\text{DD}} = 2.5\text{V}$, $\text{REFOUT1,2} = 4.096\text{V}$, $f_{\text{SMPL}} = 5\text{MHz}$.

Note 5: Recommended operating conditions.

Note 6: Integral nonlinearity is defined as the deviation of a code from a straight line passing through the actual endpoints of the transfer curve. The deviation is measured from the center of the quantization band.

Note 7: Bipolar zero error is the offset voltage measured from -0.5LSB when the output code flickers between 0000 0000 0000 0000 and 1111 1111 1111 1111. Full-scale bipolar error is the worst-case of $-\text{FS}$ or

$+\text{FS}$ un-trimmed deviation from ideal first and last code transitions and includes the effect of offset error.

Note 8: All specifications in dB are referred to a full-scale $\pm 4.096\text{V}$ input with $\text{REFIN} = 4.096\text{V}$.

Note 9: When REFOUT1,2 is overdriven, the internal reference buffer must be turned off by setting $\text{REFINT} = 0\text{V}$.

Note 10: $f_{\text{SMPL}} = 5\text{MHz}$, I_{REFBUF} varies proportionally with sample rate.

Note 11: Guaranteed by design, not subject to test.

Note 12: Parameter tested and guaranteed at $\text{OV}_{\text{DD}} = 1.71\text{V}$ and $\text{OV}_{\text{DD}} = 2.5\text{V}$.

Note 13: t_{SCK} of 9.4ns maximum allows a shift clock frequency up to 105MHz for rising edge capture.

Note 14: Temperature coefficient is calculated by dividing the maximum change in output voltage by the specified temperature range.

Note 15: $\overline{\text{CNV}}$ is driven from a low jitter digital source, typically at OV_{DD} logic levels. This input pin has a TTL style input that will draw a small amount of current.

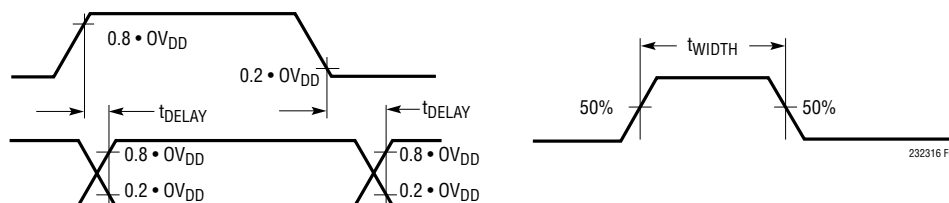
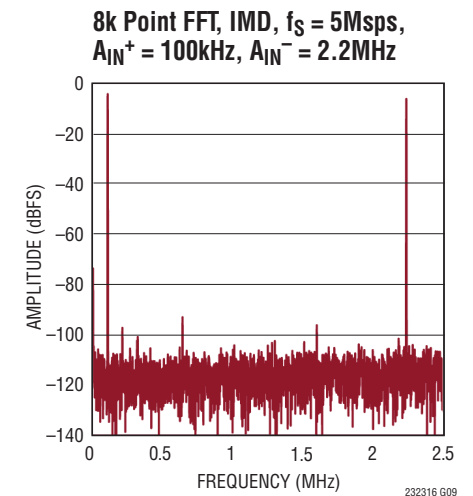
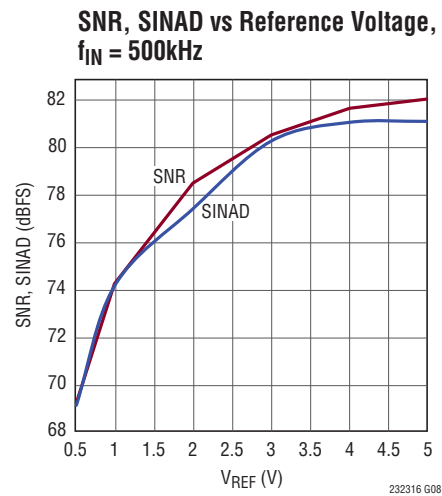
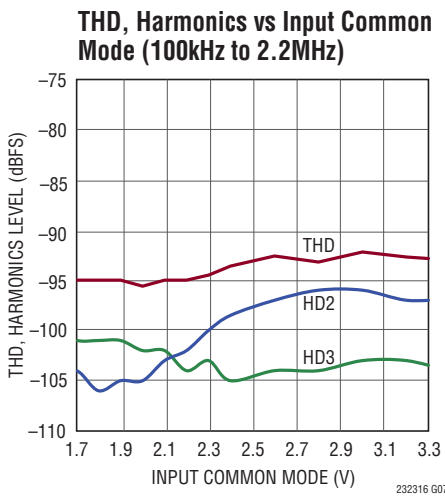
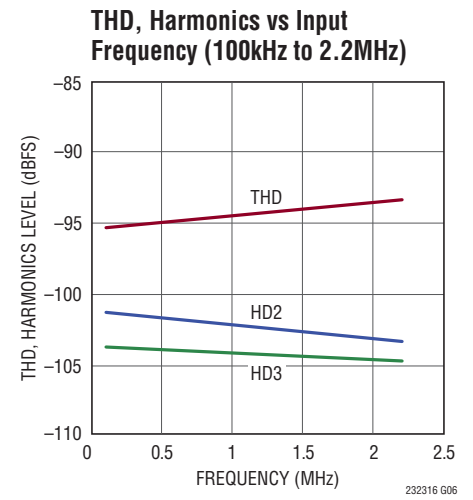
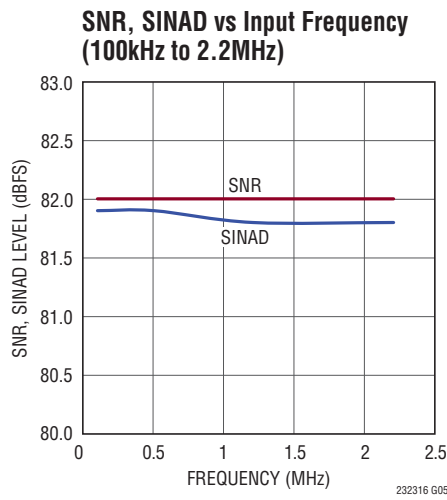
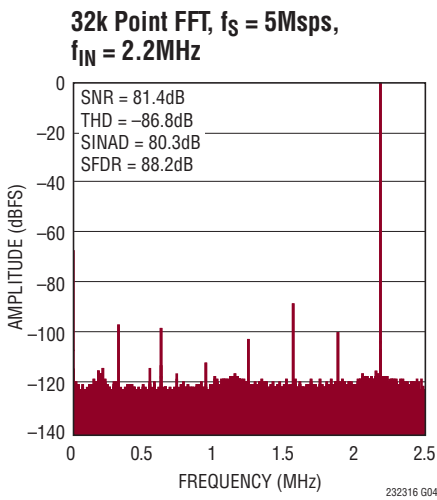
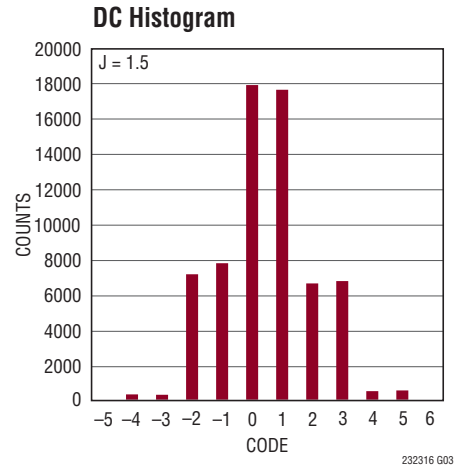
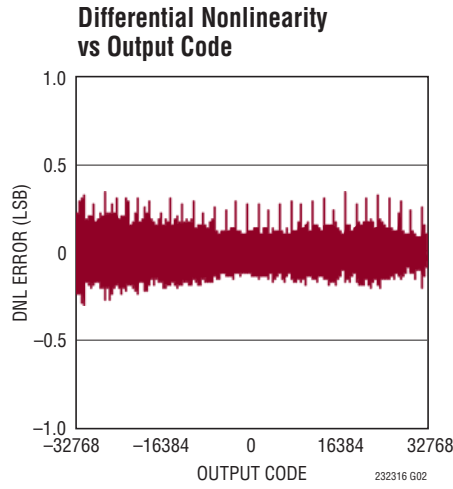
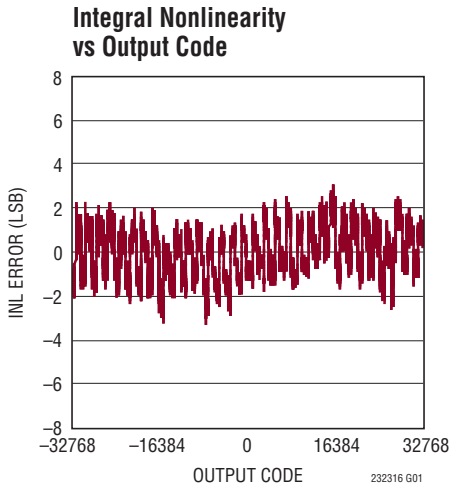

Figure 1. Voltage Levels for Timing Specifications

TYPICAL PERFORMANCE CHARACTERISTICS

4.096V, $f_{SAMPL} = 5\text{Mpsps}$, unless otherwise noted.

$T_A = 25^\circ\text{C}$, $V_{DD} = 5\text{V}$, $OV_{DD} = 2.5\text{V}$, $REFOUT1,2 =$



TYPICAL PERFORMANCE CHARACTERISTICS $T_A = 25^\circ\text{C}$, $V_{DD} = 5\text{V}$, $OV_{DD} = 2.5\text{V}$, $REF_{OUT1,2} = 4.096\text{V}$, $f_{SAMPL} = 5\text{Mps}$, unless otherwise noted.

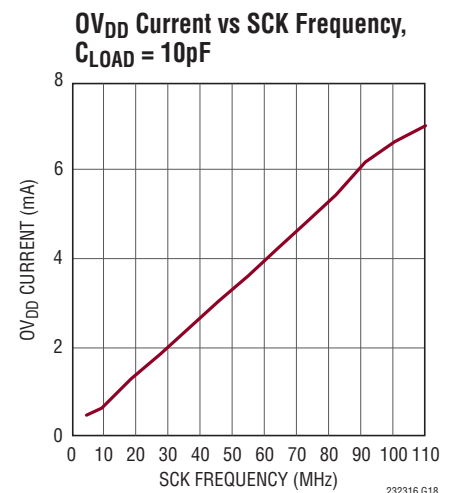
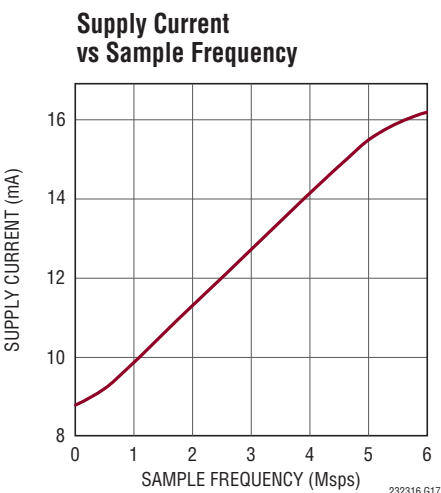
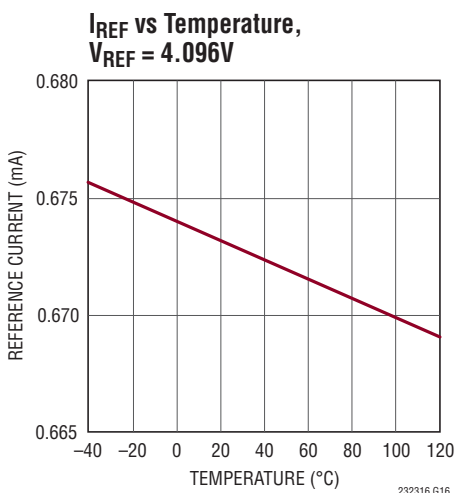
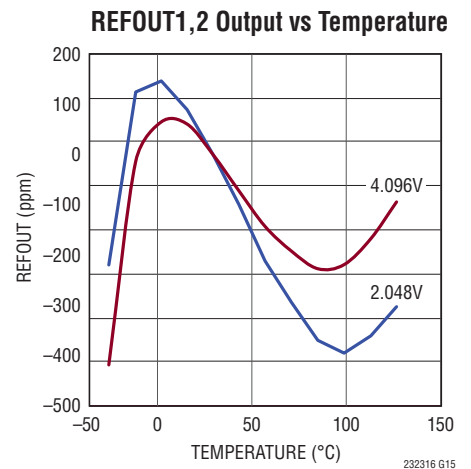
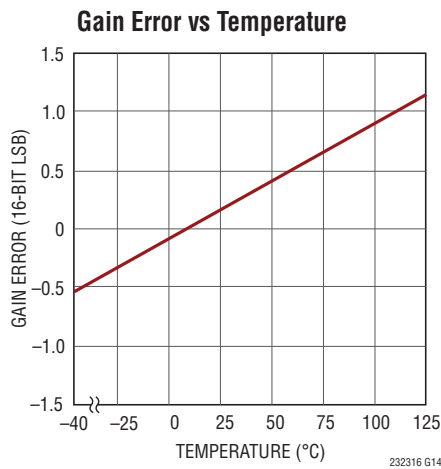
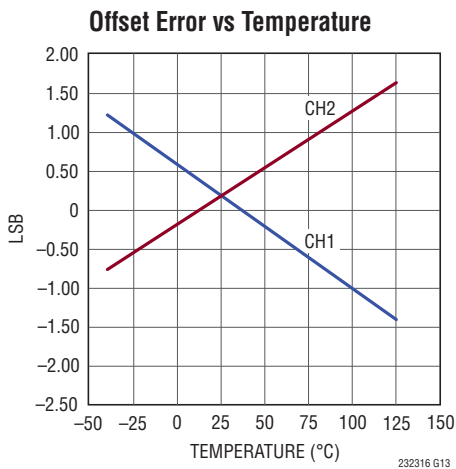
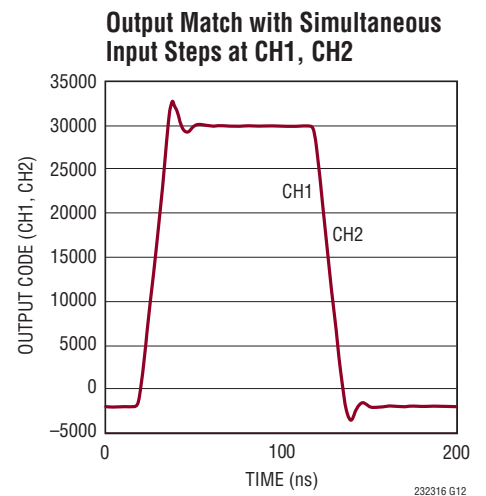
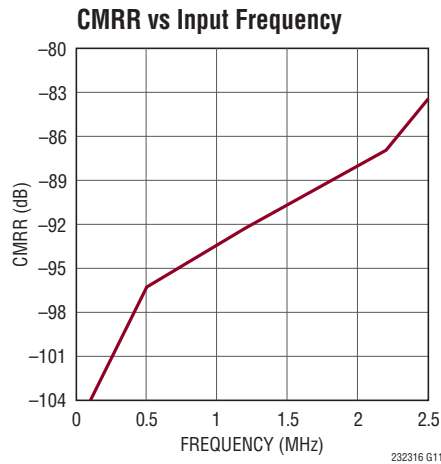
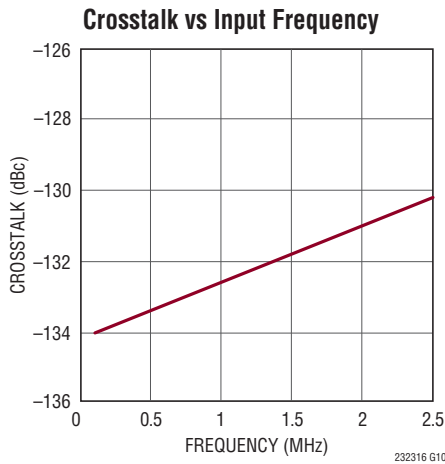

PIN FUNCTIONS

V_{DD} (Pins 1, 8): Power Supply. Bypass V_{DD} to GND with a 10μF ceramic and a 0.1μF ceramic close to the part. The V_{DD} pins should be shorted together and driven from the same supply.

A_{IN2+}, A_{IN2-} (Pins 2, 3): Analog Differential Input Pins. Full-scale range (A_{IN2+} – A_{IN2-}) is ±REFOUT2 voltage. These pins can be driven from V_{DD} to GND.

GND (Pins 4, 5, 10, 29): Ground. These pins and exposed pad (Pin 29) must be tied directly to a solid ground plane.

A_{IN1-}, A_{IN1+} (Pins 6, 7): Analog Differential Input Pins. Full-scale range (A_{IN1+} – A_{IN1-}) is ±REFOUT1 voltage. These pins can be driven from V_{DD} to GND.

CNV (Pin 9): Conversion Start Input. A falling edge on CNV puts the internal sample-and-hold into the hold mode and starts a conversion cycle. CNV must be driven by a low jitter clock as shown in the application circuit on page 26. The CNV pin is unaffected by the CMOS/LVDS pin.

REFRTN1 (Pin 11): Reference Buffer 1 Output Return. Bypass REFRTN1 to REFOUT1. Do not tie the REFRTN1 pin to the ground plane.

REFOUT1 (Pin 12): Reference Buffer 1 Output. An onboard buffer nominally outputs 4.096V to this pin. This pin is referred to REFRTN1 and should be decoupled closely to the pin (no vias) with a 0.1μF (X7R, 0402 size) capacitor and a 10μF (X5R, 0805 size) ceramic capacitor in parallel. The internal buffer driving this pin may be disabled by grounding the REFINT pin. If the buffer is disabled, an external reference may drive this pin in the range of 1.25V to 5V.

VBYP1 (Pin 13): Bypass this internally supplied pin to ground with a 1μF ceramic capacitor. The nominal output voltage on this pin is 1.6V.

OV_{DD} (Pin 14): I/O Interface Digital Power. The range of OV_{DD} is 1.71V to 2.5V. This supply is nominally set to the same supply as the host interface (CMOS: 1.8V or 2.5V, LVDS: 2.5V). Bypass OV_{DD} to OGND with a 0.1μF capacitor.

SDO1⁺, SDO1⁻ (Pins 15, 16): Channel 1 Serial Data Output. The conversion result is shifted MSB first on each falling edge of SCK. In CMOS mode, the result is output on SDO1⁺. The logic level is determined by OV_{DD}. Do not connect SDO1⁻. In LVDS mode, the result is output differentially on SDO1⁺ and SDO1⁻. These pins must be differentially terminated by an external 100Ω resistor at the receiver (FPGA).

CLKOUT⁺, CLKOUT⁻ (Pins 17, 18): Serial Data Clock Output. CLKOUT provides a skew-matched clock to latch the SDO output at the receiver. In CMOS mode, the skew-matched clock is output on CLKOUT⁺. The logic level is determined by OV_{DD}. Do not connect CLKOUT⁻. For low throughput applications using SCK to latch the SDO output, CLKOUT⁺ can be disabled by tying CLKOUT⁻ to OV_{DD}. In LVDS mode, the skew-matched clock is output differentially on CLKOUT⁺ and CLKOUT⁻. These pins must be differentially terminated by an external 100Ω resistor at the receiver (FPGA).

SDO2⁺, SDO2⁻ (Pins 19, 20): Channel 2 Serial Data Output. The conversion result is shifted MSB first on each falling edge of SCK. In CMOS mode, the result is output on SDO2⁺. The logic level is determined by OV_{DD}. Do not connect SDO2⁻. In LVDS mode, the result is output differentially on SDO2⁺ and SDO2⁻. These pins must be differentially terminated by an external 100Ω resistor at the receiver (FPGA).

SCK⁺, SCK⁻ (Pins 21, 22): Serial Data Clock Input. The falling edge of this clock shifts the conversion result MSB first onto the SDO pins. In CMOS mode, drive SCK⁺ with a single-ended clock. The logic level is determined by OV_{DD}. Do not connect SCK⁻. In LVDS mode, drive SCK⁺ and SCK⁻ with a differential clock. These pins must be differentially terminated by an external 100Ω resistor at the receiver (ADC).

OGND (Pin 23): I/O Ground. This ground must be tied to the ground plane at a single point. OV_{DD} is bypassed to this pin.

PIN FUNCTIONS

VBYP2 (Pin 24): Bypass this internally supplied pin to ground with a 1 μ F ceramic capacitor. The nominal output voltage on this pin is 1.6V

CMOS/LVDS (Pin 25): I/O Mode Select. Ground this pin to enable CMOS mode, tie to OV_{DD} to enable LVDS mode. Float this pin to enable low power LVDS mode.

REFOUT2 (Pin 26): Reference Buffer 2 Output. An onboard buffer nominally outputs 4.096V to this pin. This pin is referred to REFRTN2 and should be decoupled closely to the pin (no vias) with a 0.1 μ F (X7R, 0402 size) capacitor and a 10 μ F (X5R, 0805 size) ceramic capacitor in parallel. The internal buffer driving this pin may be disabled by grounding the REFINT pin. If the buffer is disabled, an external reference may drive this pin in the range of 1.25V to V_{DD} .

REFRTN2 (Pin 27): Reference Buffer 2 Output Return. Bypass REFRTN2 to REFOUT2. Do not tie the REFRTN2 pin to the ground plane.

REFINT (Pin 28): Reference Buffer Output Enable. Tie to V_{DD} when using the internal reference. Tie to ground to disable the internal REFOUT1 and REFOUT2 buffers for use with external voltage references. This pin has a 500k internal pull-up to V_{DD} .

Exposed Pad (Pin 29): Ground. Solder this pad to ground.

FUNCTIONAL BLOCK DIAGRAM

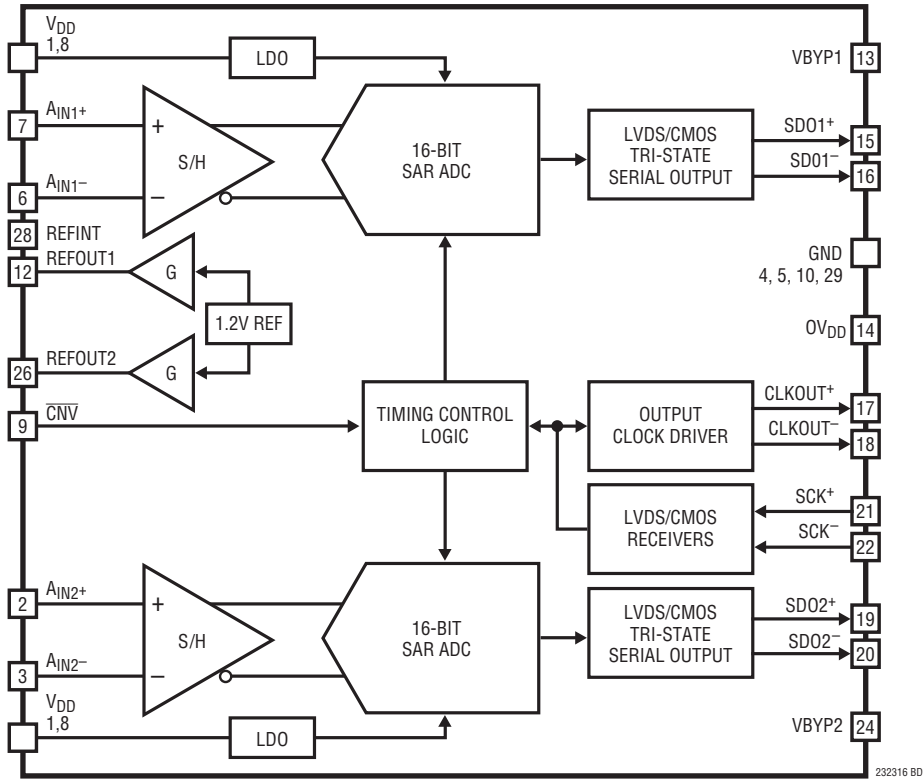

TIMING DIAGRAM

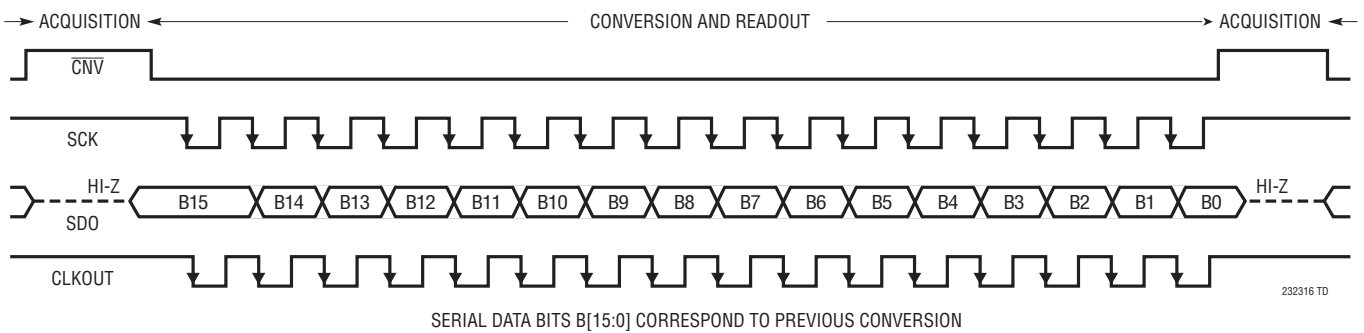

APPLICATIONS INFORMATION

OVERVIEW

The LTC2323-16 is a low noise, high speed 16-bit successive approximation register (SAR) ADC with differential inputs and a wide input common mode range. Operating from a single 3.3V or 5V supply, the LTC2323-16 has an $8V_{P-P}$ differential input range, making it ideal for applications which require a wide dynamic range. The LTC2323-16 achieves $\pm 4\text{LSB}$ INL typical, no missing codes at 16 bits and 81dB SNR.

The LTC2323-16 has an onboard reference buffer and low drift ($20\text{ppm}/^\circ\text{C}$ max) 4.096V temperature-compensated reference. The LTC2323-16 also has a high speed SPI-compatible serial interface that supports CMOS or LVDS. The fast 5MSPS per channel throughput with one-cycle latency makes the LTC2323-16 ideally suited for a wide variety of high speed applications. The LTC2323-16 dissipates only 45mW per channel. Nap and sleep modes are also provided to reduce the power consumption of the LTC2323-16 during inactive periods for further power savings.

CONVERTER OPERATION

The LTC2323-16 operates in two phases. During the acquisition phase, the sample capacitor is connected to the analog input pins A_{IN+} and A_{IN-} to sample the differential analog input voltage, as shown in Figure 3. A falling edge on the \overline{CNV} pin initiates a conversion. During the conversion phase, the 16-bit CDAC is sequenced through a successive approximation algorithm for each

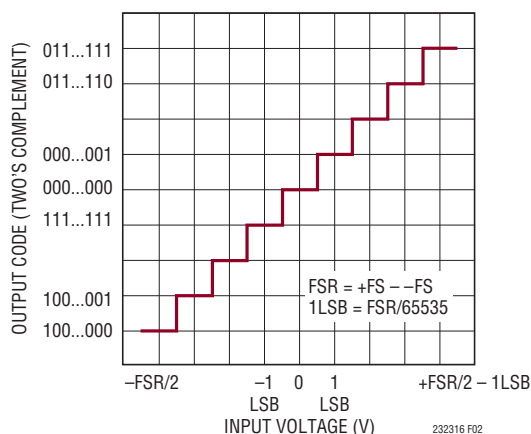

Figure 2. LTC2323-16 Transfer Function

input SCK pulse, effectively comparing the sampled input with binary-weighted fractions of the reference voltage (e.g., $V_{\text{REFOUT}}/2$, $V_{\text{REFOUT}}/4$... $V_{\text{REFOUT}}/32768$) using a differential comparator. At the end of conversion, a CDAC output approximates the sampled analog input. The ADC control logic then prepares the 16-bit digital output code for serial transfer.

TRANSFER FUNCTION

The LTC2323-16 digitizes the full-scale voltage of $2 \times \text{REFOUT}_{1,2}$ into 2^{16} levels, resulting in an LSB size of $125\mu\text{V}$ with $\text{REFBUF} = 4.096\text{V}$. The ideal transfer function is shown in Figure 2. The output data is in 2's complement format.

Analog Input

The differential inputs of the LTC2323-16 provide great flexibility to convert a wide variety of analog signals with no configuration required. The LTC2323-16 digitizes the difference voltage between the A_{IN+} and A_{IN-} pins while supporting a wide common mode input range. The analog input signals can have an arbitrary relationship to each other, provided that they remain between V_{DD} and GND. The LTC2323-16 can also digitize more limited classes of analog input signals such as pseudo-differential unipolar/bipolar and fully differential with no configuration required.

The analog inputs of the LTC2323-16 can be modeled by the equivalent circuit shown in Figure 3. The back-to-back diodes at the inputs form clamps that provide ESD

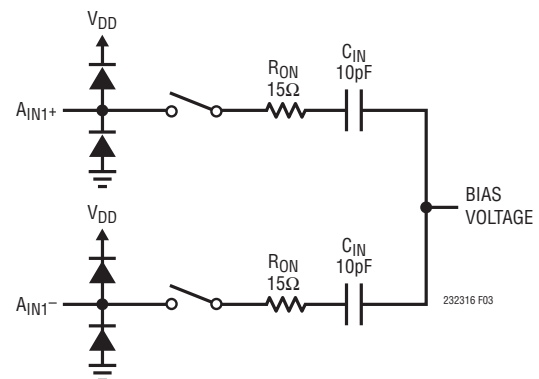

Figure 3. The Equivalent Circuit for the Differential Analog Input of the LTC2323-16

APPLICATIONS INFORMATION

protection. In the acquisition phase, 10pF (C_{IN}) from the sampling capacitor in series with approximately 15Ω (R_{ON}) from the on-resistance of the sampling switch is connected to the input. Any unwanted signal that is common to both inputs will be reduced by the common mode rejection of the ADC sampler. The inputs of the ADC core draw a small current spike while charging the C_{IN} capacitors during acquisition.

Single-Ended Signals

Single-ended signals can be directly digitized by the LTC2323-16. These signals should be sensed pseudo-differentially for improved common mode rejection. By connecting the reference signal (e.g., ground sense) of the main analog signal to the other A_{IN} pin, any noise or disturbance common to the two signals will be rejected by the high CMRR of the ADC. The LTC2323-16 flexibility handles both pseudo-differential unipolar and bipolar

signals, with no configuration required. The wide common mode input range relaxes the accuracy requirements of any signal conditioning circuits prior to the analog inputs.

Pseudo-Differential Bipolar Input Range

The pseudo-differential bipolar configuration represents driving one of the analog inputs at a fixed voltage, typically $V_{REF}/2$, and applying a signal to the other A_{IN} pin. In this case the analog input swings symmetrically around the fixed input yielding bipolar two's complement output codes with an ADC span of half of full-scale. This configuration is illustrated in Figure 4, and the corresponding transfer function in Figure 5. The fixed analog input pin need not be set at $V_{REF}/2$, but at some point within the V_{DD} rails allowing the alternate input to swing symmetrically around this voltage. If the input signal ($A_{IN+} - A_{IN-}$) swings beyond $\pm REFOUT1,2/2$, valid codes will be generated by the ADC and must be clamped by the user, if necessary.

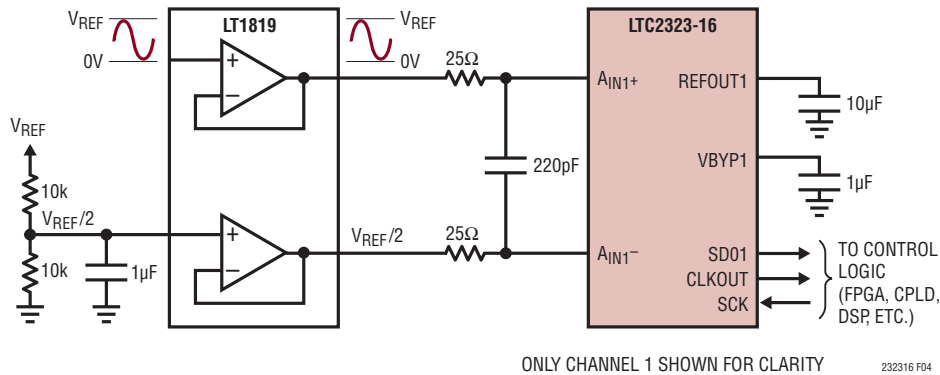

Figure 4. Pseudo-Differential Bipolar Application Circuit

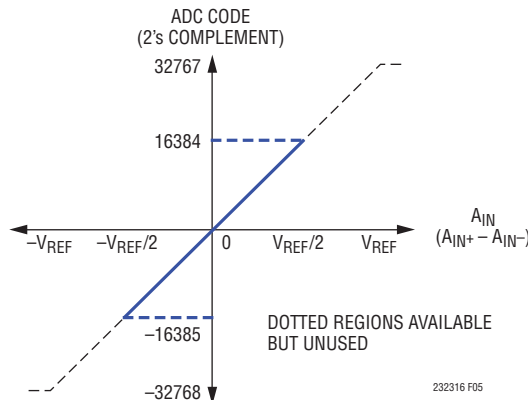

Figure 5. Pseudo-Differential Bipolar Transfer Function

APPLICATIONS INFORMATION

Pseudo-Differential Unipolar Input Range

The pseudo-differential unipolar configuration represents driving one of the analog inputs at ground and applying a signal to the other A_{IN} pin. In this case, the analog input swings between ground and V_{REF} yielding unipolar two's

complement output codes with an ADC span of half of full-scale. This configuration is illustrated in Figure 6, and the corresponding transfer function in Figure 7. If the input signal ($A_{IN+} - A_{IN-}$) swings negative, valid codes will be generated by the ADC and must be clamped by the user, if necessary.

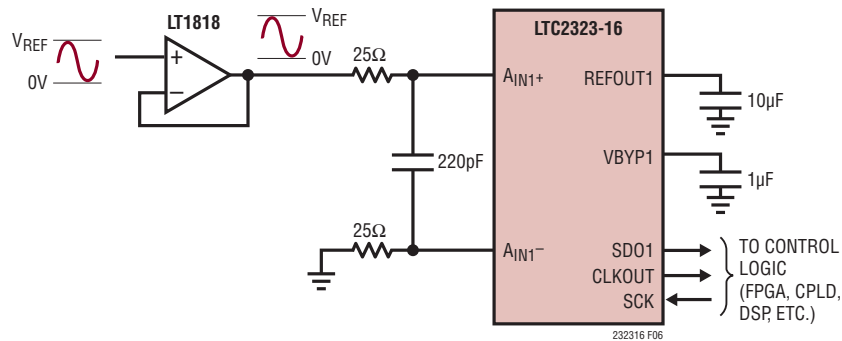

Figure 6. Pseudo-Differential Unipolar Application Circuit

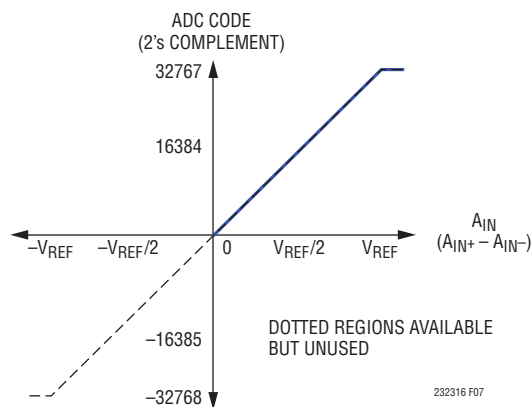

Figure 7. Pseudo-Differential Unipolar Transfer Function

APPLICATIONS INFORMATION

Single-Ended-to-Differential Conversion

While single-ended signals can be directly digitized as previously discussed, single-ended to differential conversion circuits may also be used when higher dynamic range is desired. By producing a differential signal at the inputs of the LTC2323-16, the signal swing presented to the ADC is maximized, thus increasing the achievable SNR.

The LT[®]1819 high speed dual operational amplifier is recommended for performing single-ended-to-differential conversions, as shown in Figure 8. In this case, the first amplifier is configured as a unity-gain buffer and the single-ended input signal directly drives the high impedance input of this amplifier.

Fully-Differential Inputs

To achieve the full distortion performance of the LTC2323-16, a low distortion fully-differential signal source driven through the LT1819 configured as two unity-gain buffers, as shown in Figure 9, can be used. This circuit achieves the full data sheet THD specification of -85dB at input frequencies of 500kHz and less. Data sheet typical performance curves taken at higher frequencies used a harmonic

rejection filter between the ADC and the signal source to eliminate the op amp as the dominant source of distortion.

The fully-differential configuration yields an analog input span ($A_{IN+} - A_{IN-}$) of $\pm\text{REFOUT}_{1,2}$. In this configuration, the input signal is driven on each AIN pin, typically at equal spans but opposite polarity. This yields a high common mode rejection on the input signals. The common mode voltage of the analog input can be anywhere within the V_{DD} input range, but will be limited by the peak swing of the full-range input signal. For example, if the internal reference is used with $V_{DD} = 5V_{DC}$, the full-range input span will be $\pm 4.096V$. Half of the input span is typically driven on each AIN pin, yielding a signal span for each AIN pin of $4.096V_{P-P}$. This leaves $\sim 0.9V$ of common mode variation tolerance. When using external references, it is possible to increase common mode tolerance by compressing the ADC full-range codes into a tighter range. For example, using an external $2.048V$ reference with $V_{DD} = 5V$ the total span would be $\pm 2.048V$ and each AIN span would be limited to $2.048V_{P-P}$ allowing a common mode range of $\sim 3V$. Compressing the input span would incur a SNR penalty of approximately 2dB. Input span compression may be useful if single-supply analog input drivers

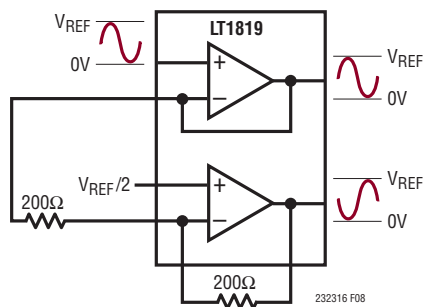

Figure 8. Single-Ended to Differential Driver

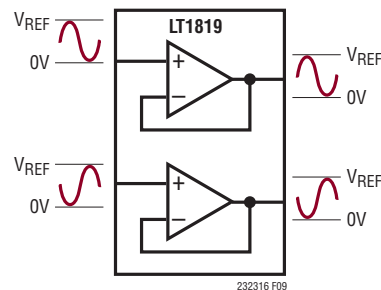

Figure 9. LT1819 Buffering a Fully-Differential Signal Source

APPLICATIONS INFORMATION

are used which cannot swing rail-to-rail. The fully-differential configuration is illustrated in Figure 10, with the corresponding transfer function illustrated in Figure 11.

INPUT DRIVE CIRCUITS

A low impedance source can directly drive the high impedance inputs of the LTC2323-16 without gain error. A high impedance source should be buffered to minimize settling time during acquisition and to optimize the distortion performance of the ADC. Minimizing settling time is

important even for DC inputs, because the ADC inputs draw a current spike when during acquisition.

For best performance, a buffer amplifier should be used to drive the analog inputs of the LTC2323-16. The amplifier provides low output impedance to minimize gain error and allow for fast settling of the analog signal during the acquisition phase. It also provides isolation between the signal source and the ADC inputs, which draw a small current spike during acquisition.

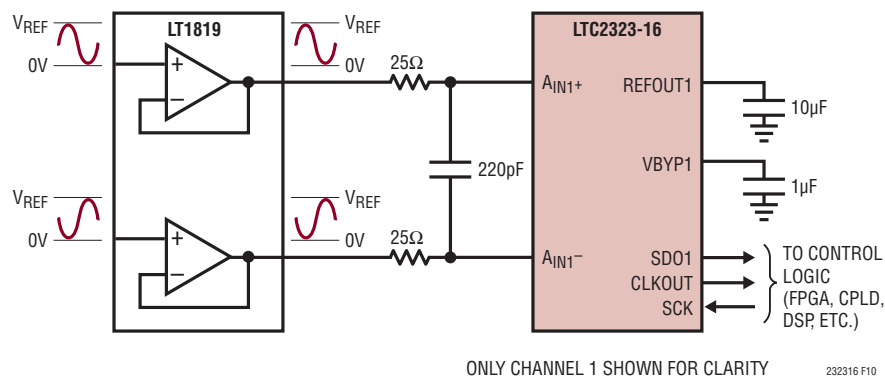

Figure 10. Fully-Differential Application Circuit

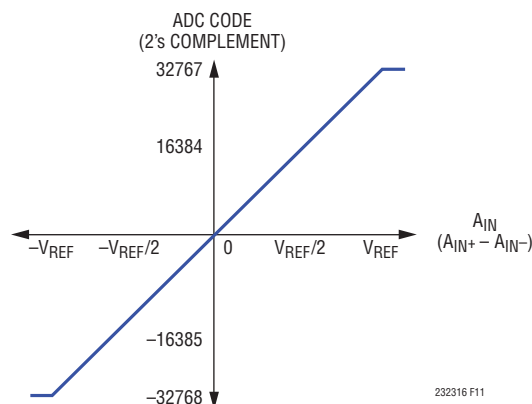

Figure 11. Fully-Differential Transfer Function

APPLICATIONS INFORMATION

Input Filtering

The noise and distortion of the buffer amplifier and signal source must be considered since they add to the ADC noise and distortion. Noisy input signals should be filtered prior to the buffer amplifier input with a low bandwidth filter to minimize noise. The simple 1-pole RC lowpass filter shown in Figure 12 is sufficient for many applications.

The input resistor divider network, sampling switch on-resistance (R_{ON}) and the sample capacitor (C_{IN}) form a second lowpass filter that limits the input bandwidth to the ADC core to 110MHz. A buffer amplifier with a low noise density must be selected to minimize the degradation of the SNR over this bandwidth.

High quality capacitors and resistors should be used in the RC filters since these components can add distortion. NPO and silver mica type dielectric capacitors have excellent linearity. Carbon surface mount resistors can generate distortion from self heating and from damage that may occur during soldering. Metal film surface mount resistors are much less susceptible to both problems.

ADC REFERENCE

Internal Reference

The LTC2323-16 has an on-chip, low noise, low drift (20ppm/°C max), temperature compensated bandgap reference. It is internally buffered and is available at REFOUT1,2 (Pins 12, 26). The reference buffer gains the internal reference voltage to 4.096V for supply voltages $V_{DD} = 5V$ and to 2.048V for $V_{DD} = 3.3V$. Bypass REFOUT1,2 to REFRTN1,2 with the parallel combination of a 0.1 μ F (X7R, 0402 size) capacitor and a 10 μ F (X5R, 0805 size) ceramic capacitor to compensate the reference buffer and minimize noise. The 0.1 μ F capacitor should be as close as possible to the LTC2323-16 package to minimize wiring inductance. Tie the REFINT pin to V_{DD} to enable the internal reference buffer.

Table 1. REFOUT1,2 Sources and Ranges vs V_{DD}

V_{DD}	REFINT PIN	REFOUT1,2 PIN	DIFFERENTIAL SPAN
5V	5V	Internal 4.096V	$\pm 4.096V$
5V	0V	External (1.25V to 5V)	$\pm 1.25V$ to $\pm 5V$
3.3V	3.3V	Internal 2.048V	$\pm 2.048V$
3.3V	0V	External (1.25V to 3.3V)	$\pm 1.25V$ to $\pm 3.3V$

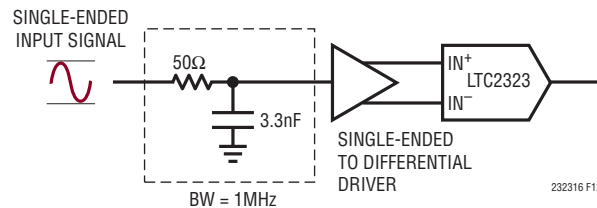

Figure 12. Input Signal Chain

APPLICATIONS INFORMATION

External Reference

The internal reference buffer can also be overdriven from 1.25V to 5V with an external reference at REFOUT1,2 as shown in Figure 13 (b and c). To do so, REFINT must be grounded to disable the reference buffer. A 55k internal resistance loads the REFOUT1,2 pins when the reference buffer is disabled. To maximize the input signal swing and corresponding SNR, the LTC6655-5 is recommended when overdriving REFOUT. The LTC6655-5 offers the same small size, accuracy, drift and extended temperature range as the LTC6655-4.096. By using a 5V reference, a higher SNR can be achieved. We recommend bypassing the LTC6655-5 with a parallel combination of

a 0.1 μ F (X7R, 0402 size) ceramic capacitor and a 10 μ F ceramic capacitor (X5R, 0805 size) close to each of the REFOUT1,2 and REFRTN1,2 pins.

Internal Reference Buffer Transient Response

The REFOUT1,2 pins of the LTC2323-16 draw charge (Q_{CONV}) from the external bypass capacitors during each conversion cycle. If the internal reference buffer is overdriven, the external reference must provide all of this charge with a DC current equivalent to $I_{REF} = Q_{CONV}/t_{CYC}$. Thus, the DC current draw of REFOUT1,2 depends on the sampling rate and output code. In applications where a burst of samples is taken after idling for long

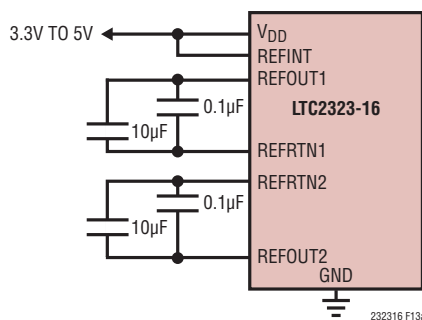

(13a) LTC2323-16 Internal Reference Circuit

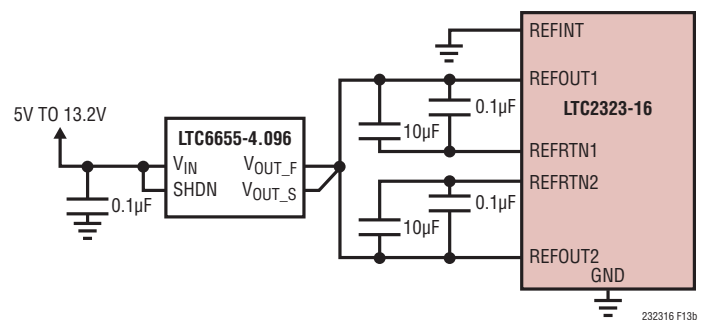

(13b) LTC2323-16 with a Shared External Reference Circuit

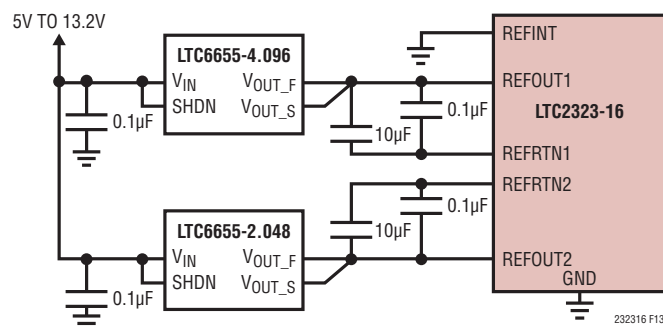

(13c) LTC2323-16 with Different External Reference Voltages

Figure 13. Reference Connections

APPLICATIONS INFORMATION

periods, as shown in Figure 14, I_{REFBUF} quickly goes from approximately $\sim 75\mu A$ to a maximum of $500\mu A$ for $REFOUT = 5V$ at $5Mps$. This step in DC current draw triggers a transient response in the external reference that must be considered since any deviation in the voltage at $REFOUT$ will affect the accuracy of the output code. Due to the one-cycle conversion latency, the first conversion result at the beginning of a burst sampling period will be invalid. If an external reference is used to overdrive $REFOUT_{1,2}$ the fast settling LTC6655 reference is recommended.

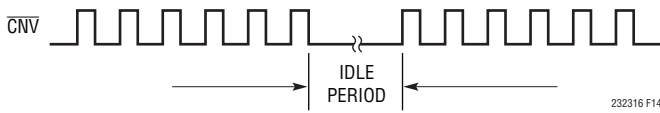

Figure 14. \overline{CNV} Waveform Showing Burst Sampling

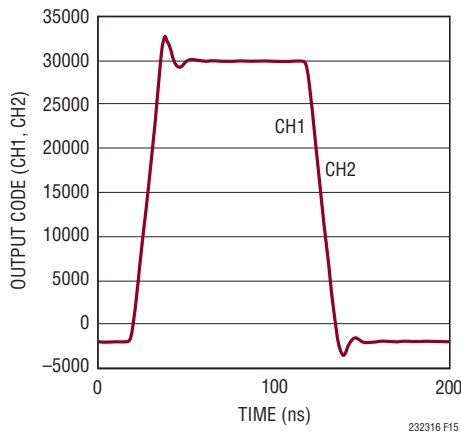

Figure 15. Transient Response of the LTC2323-16

DYNAMIC PERFORMANCE

Fast Fourier transform (FFT) techniques are used to test the ADC's frequency response, distortion and noise at the rated throughput. By applying a low distortion sine wave and analyzing the digital output using an FFT algorithm, the ADC's spectral content can be examined for frequencies outside the fundamental. The LTC2323-16 provides guaranteed tested limits for both AC distortion and noise measurements.

Signal-to-Noise and Distortion Ratio (SINAD)

The signal-to-noise and distortion ratio (SINAD) is the ratio between the RMS amplitude of the fundamental input frequency and the RMS amplitude of all other frequency components at the A/D output. The output is bandlimited to frequencies from above DC and below half the sampling frequency. Figure 16 shows that the LTC2323-16 achieves a typical SINAD of 80dB at a 5MHz sampling rate with a 2.2MHz input.

Signal-to-Noise Ratio (SNR)

The signal-to-noise ratio (SNR) is the ratio between the RMS amplitude of the fundamental input frequency and the RMS amplitude of all other frequency components except the first five harmonics and DC. Figure 16 shows that the LTC2323-16 achieves a typical SNR of 81dB at a 5MHz sampling rate with a 2.2MHz input.

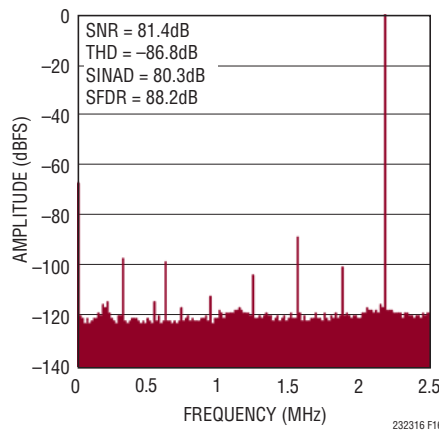

Figure 16. 32k Point FFT of the LTC2323-16

APPLICATIONS INFORMATION

Total Harmonic Distortion (THD)

Total harmonic distortion (THD) is the ratio of the RMS sum of all harmonics of the input signal to the fundamental itself. The out-of-band harmonics alias into the frequency band between DC and half the sampling frequency ($f_{\text{SAMPL}}/2$). THD is expressed as:

$$\text{THD} = 20 \log \frac{\sqrt{V_2^2 + V_3^2 + V_4^2 + \dots + V_N^2}}{V_1}$$

where V_1 is the RMS amplitude of the fundamental frequency and V_2 through V_N are the amplitudes of the second through Nth harmonics.

POWER CONSIDERATIONS

The LTC2323-16 requires two power supplies: the 5V power supply (V_{DD}), and the digital input/output interface power supply (OV_{DD}). The flexible OV_{DD} supply allows

the LTC2323-16 to communicate with any digital logic operating between 1.8V and 2.5V. When using LVDS I/O, the OV_{DD} supply must be set to 2.5V.

Power Supply Sequencing

The LTC2323-16 does not have any specific power supply sequencing requirements. Care should be taken to adhere to the maximum voltage relationships described in the Absolute Maximum Ratings section. The LTC2323-16 has a power-on-reset (POR) circuit that will reset the LTC2323-16 at initial power-up or whenever the power supply voltage drops below 2V. Once the supply voltage re-enters the nominal supply voltage range, the POR will reinitialize the ADC. No conversions should be initiated until 10ms after a POR event to ensure the reinitialization period has ended. Any conversions initiated before this time will produce invalid results.

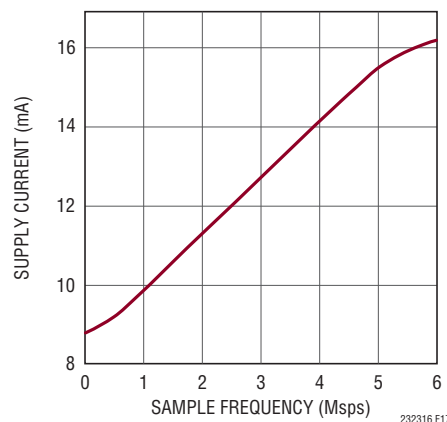

Figure 17. Power Supply Current of the LTC2323-16 Versus Sampling Rate

APPLICATIONS INFORMATION

TIMING AND CONTROL

$\overline{\text{CNV}}$ Timing

A rising edge on $\overline{\text{CNV}}$ initiates the acquisition phase and puts the internal sample-and-hold into the sample mode. A falling edge on $\overline{\text{CNV}}$ puts the internal sample-and-hold into the hold mode and starts a conversion cycle. The $\overline{\text{CNV}}$ pulse must be at least 25ns wide for proper operation. $\overline{\text{CNV}}$ must be driven by a fast low jitter signal with a fall time from OV_{DD} to below 100mV of less than 1ns. To achieve this fast falling edge, the distance from the $\overline{\text{CNV}}$ source to the $\overline{\text{CNV}}$ pin should be minimized. The trace for this pulse should be kept as narrow as possible and routed away from adjacent traces or planes to minimize capacitance. The drive strength of the gate driving the $\overline{\text{CNV}}$ line must be sufficient to yield a fast falling edge at the ADC pin to below 100mV. We recommend the applications circuit on page 26, which uses a high speed flip-flop to generate the $\overline{\text{CNV}}$ pulse to the ADC, eliminating the effect of jitter from the FPGA. If jitter from the FPGA is not a concern, the flip-flop can be eliminated and replaced with an inverter such as the NC7SZ04P5X

SCK Serial Data Clock Input

The falling edge of this clock shifts the conversion result MSB first onto the SDO pins. A 105MHz external clock must be applied at the SCK pin to achieve 5MSPS throughput.

CLKOUT Serial Data Clock Output

The CLKOUT output provides a skew-matched clock to latch the SDO output at the receiver. The timing skew of the CLKOUT and SDO outputs are matched. For high throughput applications, using CLKOUT instead of SCK to

capture the SDO output eases timing requirements at the receiver. For low throughput speed applications, CLKOUT+ can be disabled by tying CLKOUT- to OV_{DD} .

Nap/Sleep Modes

Nap mode is a method to save power without sacrificing power-up delays for subsequent conversions. Sleep mode has substantial power savings, but a power-up delay is incurred to allow the reference and power systems to become valid. To enter nap mode on the LTC2323-16, the SCK signal must be held high or low and a series of two $\overline{\text{CNV}}$ pulses must be applied. This is the case for both CMOS and LVDS modes. The second rising edge of $\overline{\text{CNV}}$ initiates the nap state. The nap state will persist until either a single rising edge of SCK is applied, or further $\overline{\text{CNV}}$ pulses are applied. The SCK rising edge will put the LTC2323-16 back into the operational (full-power) state. When in nap mode, two additional pulses will put the LTC2323-16 in sleep mode. When configured for CMOS I/O operation, a single rising edge of SCK can return the LTC2323-16 into operational mode. A 10ms delay is necessary after exiting sleep mode to allow the reference buffer to recharge the external filter capacitor. In LVDS mode, exit sleep mode by supplying a fifth $\overline{\text{CNV}}$ pulse. The fifth pulse will return the LTC2323-16 to operational mode, and further SCK pulses will keep the part from re-entering nap and sleep modes. The fifth SCK pulse also works in CMOS mode as a method to exit sleep. In the absence of SCK pulses, repetitive $\overline{\text{CNV}}$ pulses will cycle the LTC2323-16 between operational, nap and sleep modes indefinitely.

Refer to the timing diagrams in Figure 18, Figure 19, Figure 20 and Figure 21 for more detailed timing information about sleep and nap modes.

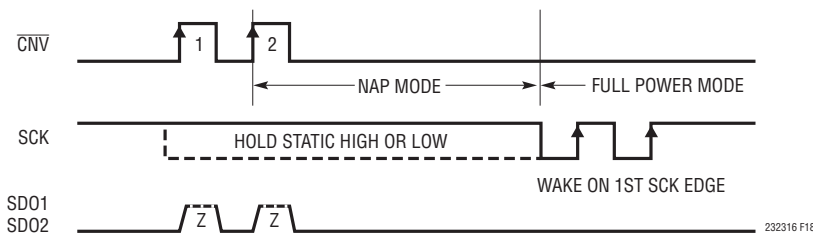

Figure 18. CMOS and LVDS Mode NAP and WAKE Using SCK

APPLICATIONS INFORMATION

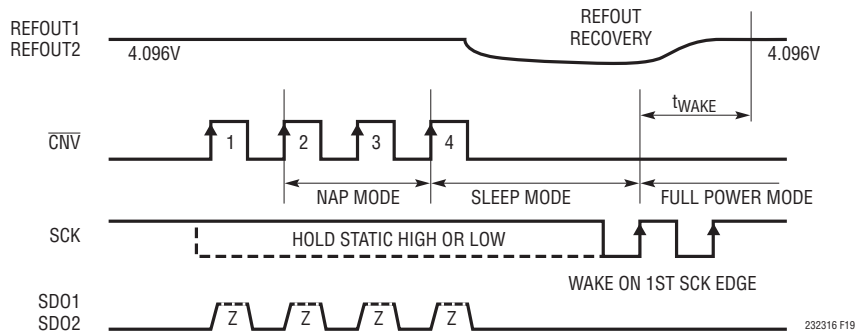

Figure 19. CMOS Mode SLEEP and WAKE Using SCK

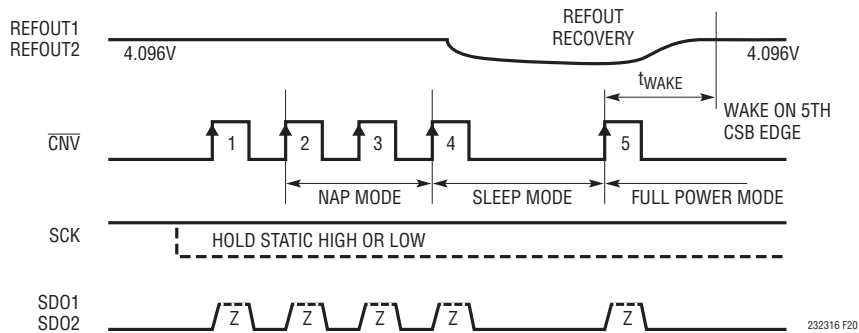

Figure 20. LVDS and CMOS Mode SLEEP and WAKE Using $\overline{\text{CNV}}$

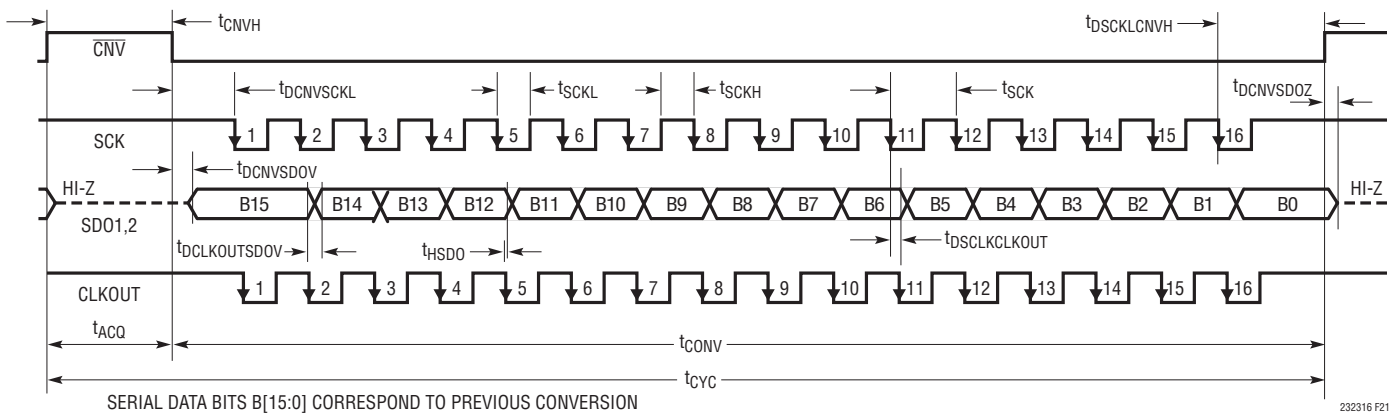

Figure 21. LTC2323-16 Timing Diagram

APPLICATIONS INFORMATION

DIGITAL INTERFACE

The LTC2323-16 features a serial digital interface that is simple and straight forward to use. The flexible OV_{DD} supply allows the LTC2323-16 to communicate with any digital logic operating between 1.8V and 2.5V. A 105MHz external clock must be applied at the SCK pin to achieve 5Msps throughput.

In addition to a standard CMOS SPI interface, the LTC2323-16 provides an optional LVDS SPI interface to support low noise digital design. The CMOS/LVDS pin is used to select the digital interface mode.

The falling edge of SCK outputs the conversion result MSB first on the SDO pins. CLKOUT provides a skew-matched clock to latch the SDO output at the receiver. The timing

skew of the CLKOUT and SDO outputs are matched. For high throughput applications, using CLKOUT instead of SCK to capture the SDO output eases timing requirements at the receiver.

In CMOS mode, use the SDO1⁺, SDO2⁺ and CLKOUT⁺ pins as outputs. Use the SCK⁺ pin as an input. Do not connect the SDO1⁻, SDO2⁻, SCK⁻ and CLKOUT⁻ pins, as they each have internal pull-down circuitry to OGND.

In LVDS mode, use the SDO1⁺/SDO1⁻, SDO2⁺/SDO2⁻ and CLKOUT⁺/CLKOUT⁻ pins as differential outputs. These pins must be differentially terminated by an external 100Ω resistor at the receiver (FPGA). The SCK⁺/SCK⁻ pins are differential inputs and must be terminated differentially by an external 100Ω resistor at the receiver (ADC).

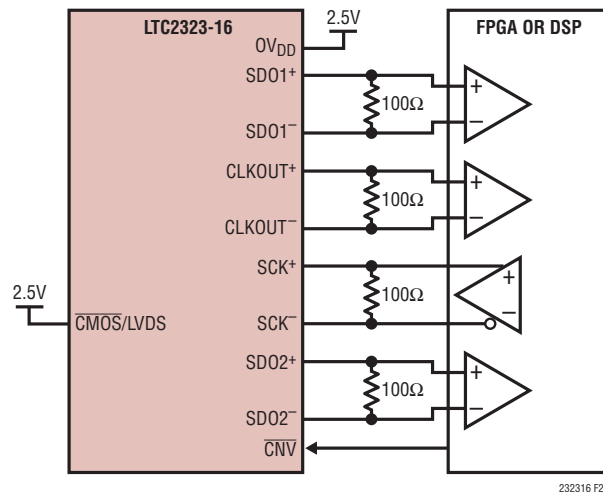

Figure 22. LTC2323 Using the LVDS Interface

APPLICATIONS INFORMATION

BOARD LAYOUT

To obtain the best performance from the LTC2323-16, a printed circuit board is recommended. Layout for the printed circuit board (PCB) should ensure the digital and analog signal lines are separated as much as possible. In particular, care should be taken not to run any digital clocks or signals adjacent to analog signals or underneath the ADC.

Recommended Layout

The following is an example of a recommended PCB layout. A single solid ground plane is used. Bypass capacitors to the supplies are placed as close as possible to the supply pins. Low impedance common returns for these bypass capacitors are essential to the low noise operation of the ADC. The analog input traces are screened by ground. For more details and information, refer to the DC1996, the evaluation kit for the LTC2323-16.

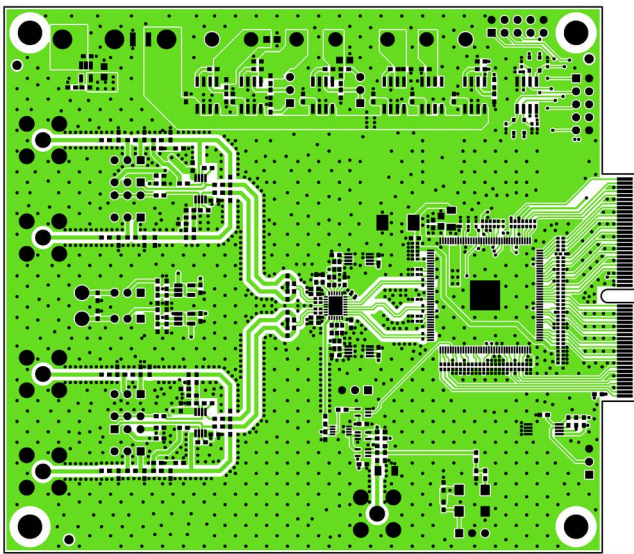

Figure 23. Layer 1, Top Layer

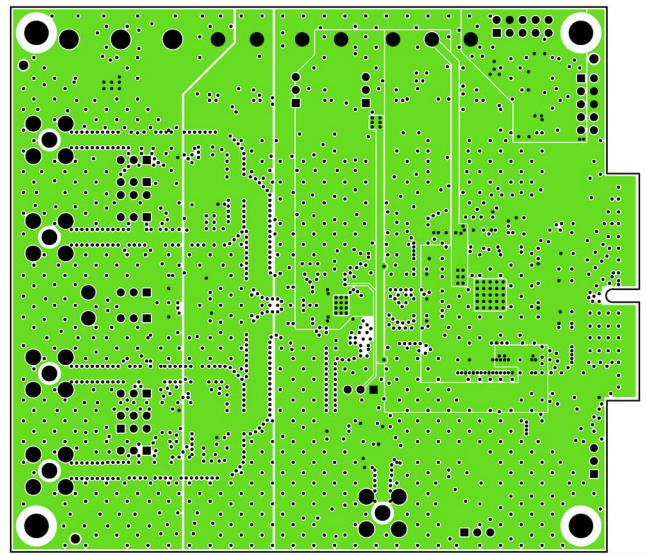

Figure 25. Layer 3, Power Plane

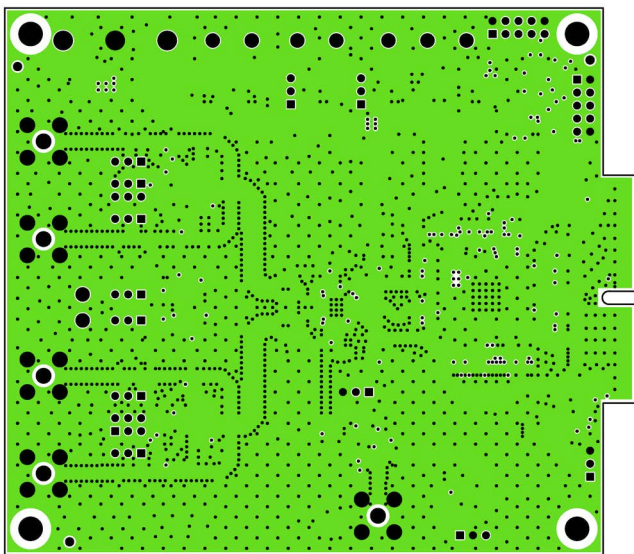

Figure 24. Layer 2, Ground Plane

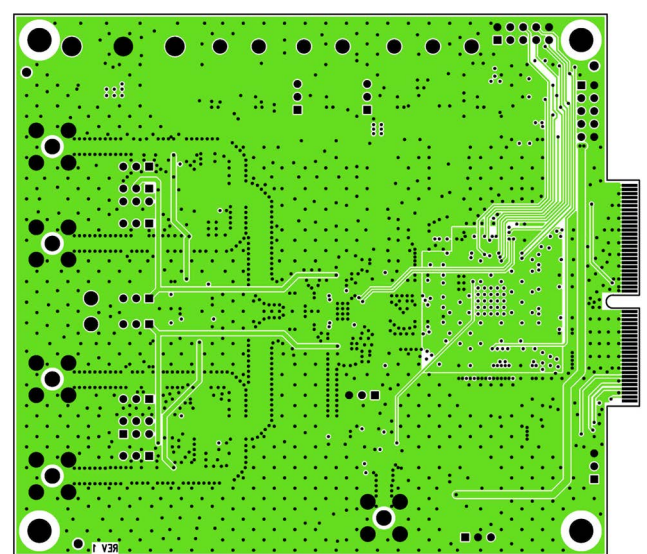
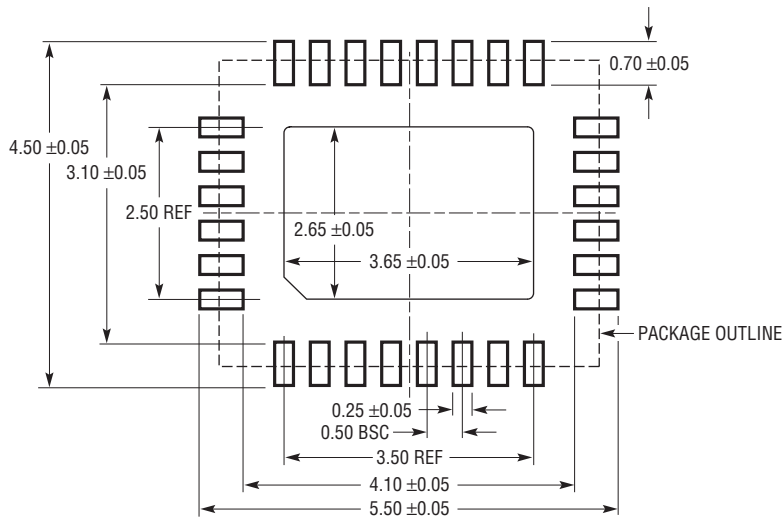

Figure 26. Layer 4, Bottom Layer

PACKAGE DESCRIPTION

Please refer to <http://www.linear.com/product/LTC2323-16#packaging> for the most recent package drawings.

UFD Package
28-Lead Plastic QFN (4mm × 5mm)
 (Reference LTC DWG # 05-08-1712 Rev C)



RECOMMENDED SOLDER PAD PITCH AND DIMENSIONS
 APPLY SOLDER MASK TO AREAS THAT ARE NOT SOLDERED

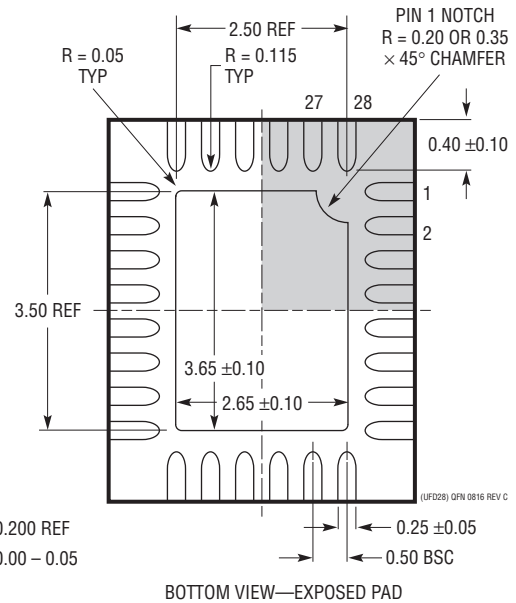
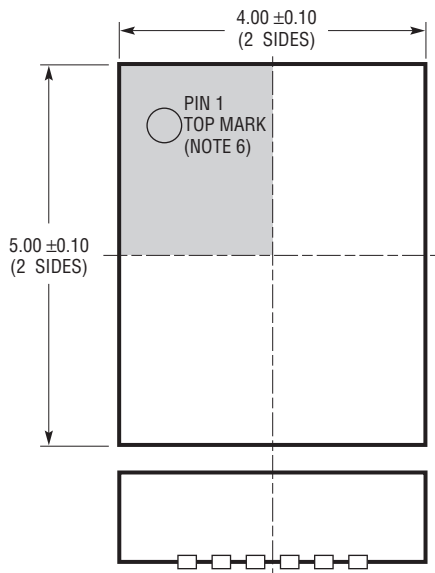

- NOTE:
1. DRAWING PROPOSED TO BE MADE A JEDEC PACKAGE OUTLINE MO-220 VARIATION (WGHD-3).
 2. DRAWING NOT TO SCALE
 3. ALL DIMENSIONS ARE IN MILLIMETERS
 4. DIMENSIONS OF EXPOSED PAD ON BOTTOM OF PACKAGE DO NOT INCLUDE MOLD FLASH. MOLD FLASH, IF PRESENT, SHALL NOT EXCEED 0.15mm ON ANY SIDE
 5. EXPOSED PAD SHALL BE SOLDER PLATED
 6. SHADED AREA IS ONLY A REFERENCE FOR PIN 1 LOCATION ON THE TOP AND BOTTOM OF PACKAGE

REVISION HISTORY

REV	DATE	DESCRIPTION	PAGE NUMBER
A	05/14	Changed y-axis units to dBFS	6
		Updated SCK, CLKOUT SDO function descriptions	8, 20, 22
		Changed SNR penalty to 2dB from 6dB	14
B	4/17	Changed \overline{CNV} pin description and Applications Information	8, 20
		Changed Fairchild components on Typical Application	26
C	10/17	Corrected minimum \overline{CNV} pulse width to 25ns.	20

TYPICAL APPLICATION

Low Jitter Clock Timing with RF Sine Generator Using Clock Squaring/Level-Shifting Circuit and Retiming Flip-Flop

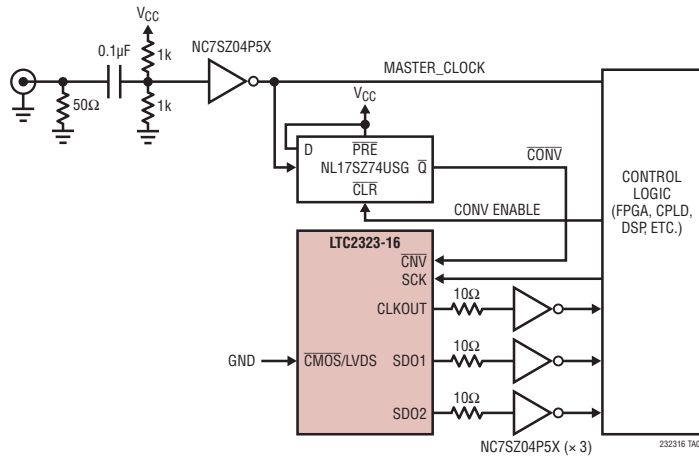

RELATED PARTS

PART NUMBER	DESCRIPTION	COMMENTS
ADCs		
LTC1407A/LTC1407A-1	12-/14-Bit, 3Msps Simultaneous Sampling ADC	3V Supply, 2-Channel Differential, 1.5Msps per Channel Throughput, Unipolar/Bipolar Inputs, 14mW, MSOP Package
LTC2314-14	14-Bit, 4.5Msps Serial ADC	3V/5V Supply, 18mW/31mW, 20ppm/°C Max Internal Reference, Unipolar Inputs, 8-Lead TSOT-23 Package
LTC2321-16/LTC2321-14/LTC2321-12	16-/14-/12-Bit, 2Msps, Simultaneous Sampling ADCs	3.3V/5V Supply, 33mW/Ch, 10ppm/°C Max Internal Reference, Flexible Inputs, 4mm × 5mm QFN-28 Package
LTC2370-16/LTC2368-16/LTC2367-16/LTC2364-16	16-Bit, 2Msps/1Msps/500ksps/250ksps Serial, Low Power ADC	2.5V Supply, Pseudo-Differential Unipolar Input, 94dB SNR, 5V Input Range, DGC, Pin-Compatible Family in MSOP-16 and 4mm × 3mm DFN-16 Packages
LTC2380-16/LTC2378-16/LTC2377-16/LTC2376-16	16-Bit, 2Msps/1Msps/500ksps/250ksps Serial, Low Power ADC	2.5V Supply, Differential Input, 96.2dB SNR, ±5V Input Range, DGC, Pin-Compatible Family in MSOP-16 and 4mm × 3mm DFN-16 Packages
DACs		
LTC2632	Dual 12-/10-/8-Bit, SPI V _{OUT} DACs with Internal Reference	2.7V to 5.5V Supply Range, 10ppm/°C Reference, External REF Mode, Rail-to-Rail Output, 8-Pin ThinSOT™ Package
LTC2602/LTC2612/LTC2622	Dual 16-/14-/12-Bit SPI V _{OUT} DACs with External Reference	300μA per DAC, 2.5V to 5.5V Supply Range, Rail-to-Rail Output, 8-Lead MSOP Package
References		
LTC6655	Precision Low Drift, Low Noise Buffered Reference	5V/4.096V/3.3V/3V/2.5V/2.048V/1.25V, 5ppm/°C, 0.25ppm Peak-to-Peak Noise, MSOP-8 Package
LTC6652	Precision Low Drift, Low Noise Buffered Reference	5V/4.096V/3.3V/3V/2.5V/2.048V/1.25V, 5ppm/°C, 2.1ppm Peak-to-Peak Noise, MSOP-8 Package
Amplifiers		
LT1818/LT1819	400MHz, 2500V/μs, 9mA Single/Dual Operational Amplifiers	–85dBc Distortion at 5MHz, 6nV/√Hz Input Noise Voltage, 9mA Supply Current, Unity-Gain Stable
LT1806	325MHz, Single, Rail-to-Rail Input and Output, Low Distortion, Low Noise Precision Op Amps	–80dBc Distortion at 5MHz, 3.5nV/√Hz Input Noise Voltage, 9mA Supply Current, Unity-Gain Stable
LT6200	165MHz, Rail-to-Rail Input and Output, 0.95nV/√Hz Low Noise, Op Amp Family	Low Noise, Low Distortion, Unity-Gain Stable

Looking for pricing, stock, or lifecycle information?

Click below to explore more details on WIN SOURCE:

- ⊖ [View LTC2323CUFD-16#TRPBF on WIN SOURCE](#)
- ⊖ [Linear Technology Information](#)

Optimize Your Supply Chain with WIN SOURCE Solutions

- ✓ Global Sourcing Solution
- ✓ Obsolete Management
- ✓ Cost Control Management
- ✓ Shortage Management
- ✓ Alternative Solution
- ✓ Excess Inventory Management