



**THE DATASHEET OF  
LTC1729CMS8-4.1#PBF**



# Li-Ion Battery Charger Termination Controllers

## FEATURES

- **Built-In Termination: 3-Hour Time-Out**
- **C/10 Detection with Status Indicator**
- Trickle Charge Preconditioning If Cell < 2.7V
- Charging Enabled When  $0^{\circ}\text{C} < T < 50^{\circ}\text{C}$
- Automatic Charger Present Detection
- Automatic Battery Present Detection
- 1- or 2-Cell, 4.1V/Cell or 4.2V/Cell Options
- Precision Internal 0.2% Voltage Feedback Divider
- Compatible with LT1505/LT1510/LT1511/LT1512/LT1513/LT1769
- Small Footprint/Low Profile

## APPLICATIONS

- Cellular Phones
- PDAs
- Cradle Chargers
- Camcorders

## DESCRIPTION

The LTC<sup>®</sup>1729 series is a family of smart termination controllers for lithium-ion battery chargers. These ICs provide trickle charge preconditioning, temperature charge qualification, time or charge current termination, automatic charger and battery detection and status output.

Combining the LTC1729 series part with the LT<sup>®</sup>1510 (1.5A), LT1769 (2A), LT1511 (3A) and LT1505 (>4A) step-down chargers is a simple operation. Connecting six pins from the LTC1729 series part to the step-down chargers completes the integration. The LTC1729 termination controllers are also compatible with step-down/step-up (SEPIC) chargers, including the LT1512 (2A switch) and LT1513 (3A switch).

The LTC1729 series is available in the 8-pin MSOP and SO packages.

 LTC and LT are registered trademarks of Linear Technology Corporation.

## TYPICAL APPLICATION

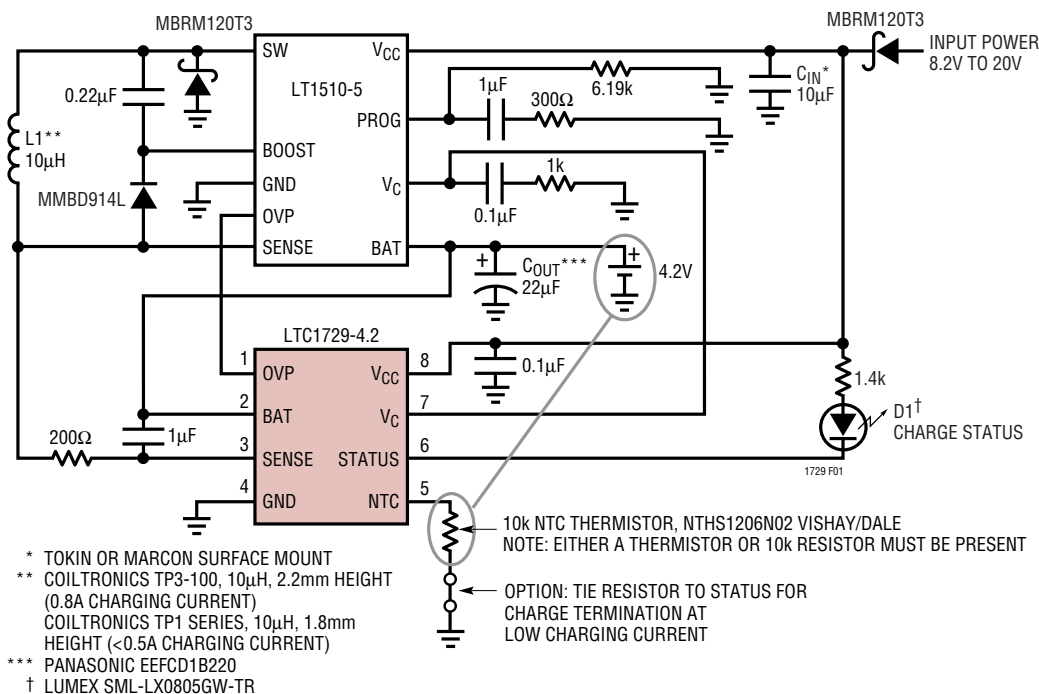

Figure 1. 500kHz Li-Ion Cell Phone Charger (0.8A)

# LTC1729 Series

## ABSOLUTE MAXIMUM RATINGS (Note 1)

$V_{CC}$ .....	30V	STATUS .....	-0.3V to 30V
SENSE, $V_{BAT}$ , NTC .....	-0.3V to 15V	Operating Temperature Range .....	0°C to 70°C
$V_C$ .....	-0.3V to 15V	Storage Temperature Range .....	-65°C to 150°C
OVP .....	-0.3V to 5V	Lead Temperature (Soldering, 10 sec) .....	300°C

## PACKAGE/ORDER INFORMATION

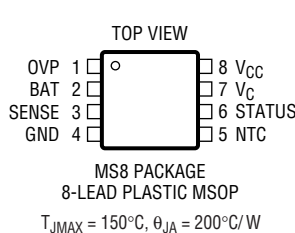
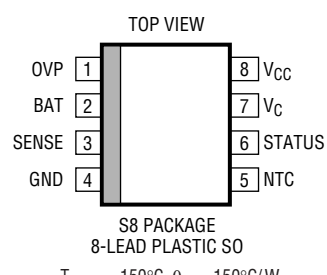
 <p>MS8 PACKAGE 8-LEAD PLASTIC MSOP <math>T_{JMAX} = 150^{\circ}C, \theta_{JA} = 200^{\circ}C/W</math></p>	ORDER PART NUMBER	 <p>S8 PACKAGE 8-LEAD PLASTIC SO <math>T_{JMAX} = 150^{\circ}C, \theta_{JA} = 150^{\circ}C/W</math></p>	ORDER PART NUMBER
	LTC1729CMS8-4.1 LTC1729CMS8-4.2 LTC1729CMS8-8.2 LTC1729CMS8-8.4		LTC1729CS8-4.1 LTC1729CS8-4.2 LTC1729CS8-8.2 LTC1729CS8-8.4
	MS8 PART MARKING		S8 PART MARKING
	LTLY LTJH LTLZ LTJG		172941 172942 172982 172984

Consult factory for Industrial and Military grade parts.

## ELECTRICAL CHARACTERISTICS

The ● denotes specifications which apply over the full operating temperature range, otherwise specifications are  $T_A = 25^{\circ}C, V_{IN} = 8V$

SYMBOL	PARAMETER	CONDITIONS	LTC1729-4.1/LTC1729-4.2			UNITS	
			MIN	TYP	MAX		
<b>DC CHARACTERISTICS</b>							
$I_{CC}$	$V_{CC}$ Supply Current	$V_{IN} = 5V$ (Below UVLO) $V_{IN} = 8V, V_{BAT} > 4.5V$ , No Bat $V_{IN} = 8V, V_{BAT} = 2.5V$ Trickle $V_{IN} = 8V, V_{BAT} = 3.5V$ Charge	● ● ● ●	1 1.0 10 0.5	5 1.4 17 3.0	12 2.0 21 5.0	$\mu A$ mA mA mA
$V_{LKOH}$	$V_{IN}$ Undervoltage Lockout High		●	5.5	6.5	7.5	V
$V_{LKOL}$	$V_{IN}$ Undervoltage Lockout Low		●	5.0	6.0	7.0	V
$I_{VBAT}$	$V_{BAT}$ Current	$V_{IN} = 5V$ (Below UVLO), $V_{BAT} = 4.2V$ $V_{IN} = 8V, V_{BAT} = 4.25V$ No Bat $V_{IN} = 8V, V_{BAT} = 2.5V$ Trickle $V_{IN} = 8V, V_{BAT} = 3.5V$ Charge	● ● ● ●	-1 40 -19 -2.7	-0.1 73 -12 -1.3	1 120 -9.5 -0.5	$\mu A$ $\mu A$ mA mA
$V_{CLAMP}$	$V_{BAT}$ Clamp	No Bat (External 200 $\mu A$ Pull-Up on $V_{BAT}$ )	●	4.25	4.5	4.75	V
$V_{MAX}$	High $V_{BAT}$ Threshold	High Going Threshold	●	4.25	4.51	4.75	V
		Low Going Threshold	●	4.25	4.50	4.75	V
$V_{MIN}$	Low $V_{BAT}$ Threshold	High Going Threshold	●	2.55	2.7	2.85	V
		Low Going Threshold	●	2.45	2.6	2.75	V
$I_{SENSE}$	SENSE Pin Current	Charge State, $V_{SENSE} = 3V$	●	85	100	115	$\mu A$
$V_{C10}$	SENSE Pin C/10 Offset	Charge State, $V_{C10} = (V_{BAT} - V_{SENSE})$	●		$\pm 1$	$\pm 2.5$	mV

**ELECTRICAL CHARACTERISTICS**The ● denotes specifications which apply over the full operating temperature range, otherwise specifications are  $T_A = 25^\circ\text{C}$ ,  $V_{IN} = 8\text{V}$ 

SYMBOL	PARAMETER	CONDITIONS		LTC1729-4.1/LTC1729-4.2			UNITS
				MIN	TYP	MAX	
$I_{NTC}$	NTC Pin Current	$V_{NTC} = 1\text{V}$	●	90	100	110	$\mu\text{A}$
$V_{NTC-RESET}$	Thermistor Pin Reset Threshold		●	0.160	0.206	0.240	V
$V_{NTC-HOT}$	Thermistor Pin Hot Hold Threshold	High Going Threshold	●	0.460	0.486	0.510	V
		Low Going Threshold	●	0.380	0.405	0.430	V
$V_{NTC-COLD}$	Thermistor Pin Cold Hold Threshold	High Going Threshold	●	2.70	2.79	2.90	V
		Low Going Threshold	●	2.10	2.23	2.35	V
$V_{OVP}$	OVP Pin Voltage	$V_{BAT} = 4.1\text{V}$ or $V_{BAT} = 4.2\text{V}$	●	2.455	2.465	2.475	V
				2.460	2.465	2.470	V
$V_{OL-ST}$	Output Low Voltage-STATUS Pin	$I_O = 3\text{mA}$	●	0.5	0.9	1.2	V
$V_{OL-VC}$	Output Low Voltage- $V_C$ Pin	$I_O = 1\text{mA}$	●	0.35	0.6	0.75	V
$I_{SOFT}$	Status Soft Pull-Down Current	$V_{STATUS} = 4.5\text{V}$	●	40	50	65	$\mu\text{A}$

The ● denotes specifications which apply over the full operating temperature range, otherwise specifications are  $T_A = 25^\circ\text{C}$ ,  $V_{IN} = 12\text{V}$ 

SYMBOL	PARAMETER	CONDITIONS		LTC1729-8.2/LTC1729-8.4			UNITS
				MIN	TYP	MAX	
<b>DC CHARACTERISTICS</b>							
$I_{CC}$	$V_{CC}$ Supply Current	$V_{IN} = 9\text{V}$ (Below UVLO)	●	1	6	12	$\mu\text{A}$
		$V_{IN} = 12\text{V}$ , $V_{BAT} > 9\text{V}$ , No Bat	●	1.0	1.4	2.0	mA
		$V_{IN} = 12\text{V}$ , $V_{BAT} = 5\text{V}$ Trickle		10	17	21	mA
		$V_{IN} = 12\text{V}$ , $V_{BAT} = 7\text{V}$ Charge	●	0.5	3.0	5.0	mA
$V_{LKO H}$	$V_{IN}$ Undervoltage Lockout High		●	9.5	10.4	11.4	V
$V_{LKO L}$	$V_{IN}$ Undervoltage Lockout Low		●	8.5	9.6	10.5	V
$I_{VBAT}$	$V_{BAT}$ Current	$V_{IN} = 9\text{V}$ (Below UVLO), $V_{BAT} = 8.4\text{V}$	●	-1	-0.1	1	$\mu\text{A}$
		$V_{IN} = 12\text{V}$ , $V_{BAT} = 8.5\text{V}$ No Bat	●	60	95	140	$\mu\text{A}$
		$V_{IN} = 12\text{V}$ , $V_{BAT} = 5\text{V}$ Trickle		-19	-12	-9.5	mA
		$V_{IN} = 12\text{V}$ , $V_{BAT} = 7\text{V}$ Charge	●	-2.7	-1.3	-0.5	mA
$V_{CLAMP}$	$V_{BAT}$ Clamp	No Bat (External $200\mu\text{A}$ Pull-Up on $V_{BAT}$ )	●	8.5	9	9.5	V
$V_{MAX}$	High $V_{BAT}$ Threshold	High Going Threshold	●	8.5	9.013	9.5	V
		Low Going Threshold	●	8.5	9	9.5	V
$V_{MIN}$	Low $V_{BAT}$ Threshold	High Going Threshold	●	5.1	5.4	5.7	V
		Low Going Threshold	●	4.9	5.2	5.5	V
$I_{SENSE}$	SENSE Pin Current	Charge State, $V_{SENSE} = 7\text{V}$	●	85	100	115	$\mu\text{A}$
$V_{C10}$	SENSE Pin C/10 Offset	Charge State, $V_{C10} = (V_{BAT} - V_{SENSE})$	●		$\pm 1$	$\pm 2.5$	mV
$I_{NTC}$	NTC Pin Current	$V_{NTC} = 1\text{V}$	●	90	100	110	$\mu\text{A}$
$V_{NTC-RESET}$	Thermistor Pin Reset Threshold		●	0.160	0.206	0.240	V
$V_{NTC-HOT}$	Thermistor Pin Hot Hold Threshold	High Going Threshold	●	0.460	0.486	0.510	V
		Low Going Threshold	●	0.380	0.405	0.430	V
$V_{NTC-COLD}$	Thermistor Pin Cold Hold Threshold	High Going Threshold	●	2.70	2.79	2.90	V
		Low Going Threshold	●	2.10	2.23	2.35	V
$V_{OVP}$	OVP Pin Voltage	$V_{BAT} = 8.2\text{V}$ or $V_{BAT} = 8.4\text{V}$	●	2.455	2.465	2.475	V
				2.460	2.465	2.470	V
$V_{OL-ST}$	Output Low Voltage-STATUS Pin	$I_O = 3\text{mA}$	●	0.5	0.9	1.2	V
$V_{OL-VC}$	Output Low Voltage- $V_C$ Pin	$I_O = 1\text{mA}$	●	0.35	0.6	0.75	V
$I_{SOFT}$	Status Soft Pull-Down Current	$V_{STATUS} = 4.5\text{V}$	●	40	50	65	$\mu\text{A}$

## ELECTRICAL CHARACTERISTICS

The ● denotes specifications which apply over the full operating temperature range, otherwise specifications are  $T_A = 25^\circ\text{C}$ . (Note 2)

SYMBOL	PARAMETER	CONDITIONS	MIN	TYP	MAX	UNITS
<b>AC CHARACTERISTICS</b>						
TIMER1	Timer for Trickle-Charge Preconditioning		● 0.869	1	1.305	Hr
TIMER2	Timer for Charging		● 2.61	3	3.55	Hr
TIMER3	Timer for $V_{MAX}$ Filter		● 0.764	0.859	1.043	sec
TIMER4	Timer for $V_{C/10}$ Filter		● 3.055	3.5	4.17	sec
$t_{OSC}$	Oscillator Period		● 6.66	7.63	9.09	$\mu\text{s}$

**Note 1:** Absolute Maximum Ratings are those values beyond which the life of a device may be impaired.

**Note 2:**  $V_{IN} = 8\text{V}$  for LTC1729-4.1/LTC1729-4.2;  $V_{IN} = 12\text{V}$  for LTC1729-8.2/LTC1729-8.4

## TYPICAL PERFORMANCE CHARACTERISTICS

$I_{VBAT}$  vs Temperature (4.2V Version)

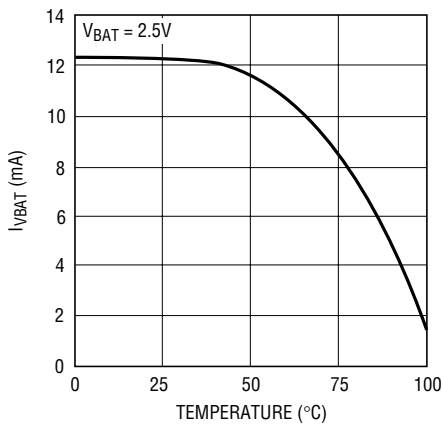

1729 G01

$I_{VBAT}$  vs Temperature (8.4V Version)

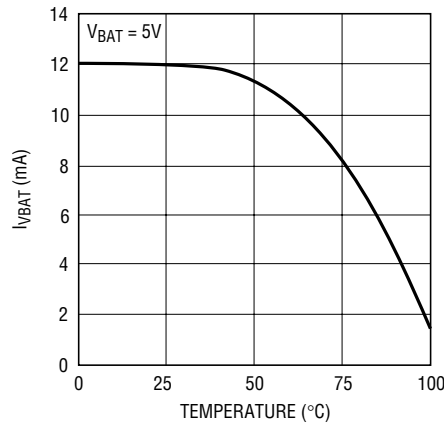

1729 G02

$I_{VBAT}$  vs  $V_{CC}$  (4.2V Version)

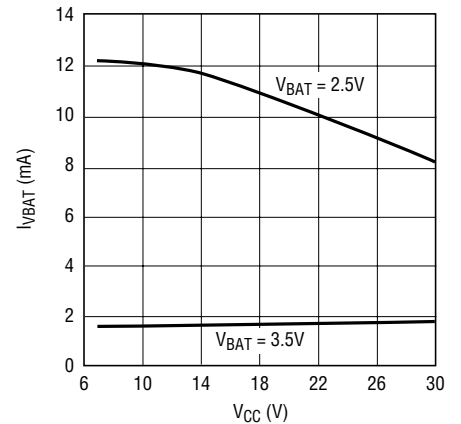

1729 G03

$I_{VBAT}$  vs  $V_{CC}$  (8.4V Version)

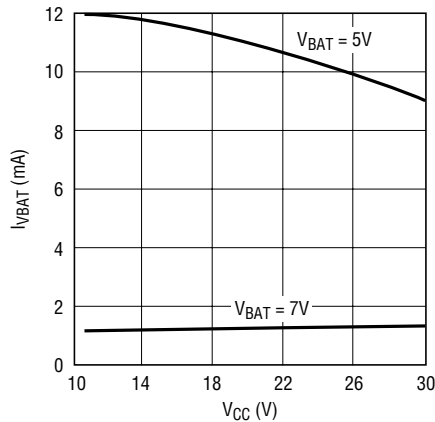

1729 G04

$I_{CC}$  vs  $V_{CC}$  (4.2V Version)

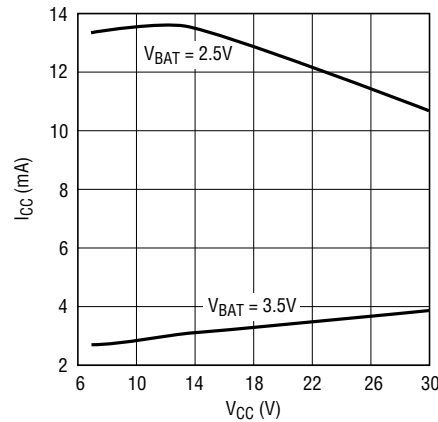

1729 G05

$I_{CC}$  vs  $V_{CC}$  (8.4V Version)

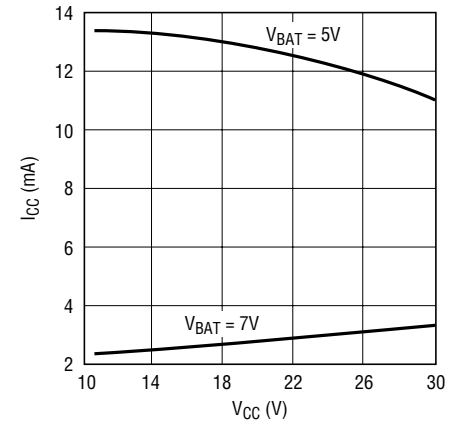

1729 G06

## PIN FUNCTIONS

**OVP (Pin 1):** Connection to an Internal Precision Resistor Divider Used as a Voltage Feedback Monitor for Constant-Voltage Mode Charging.

**BAT (Pin 2):** Input to Battery Monitor Circuits and OVP Resistor Divider. The battery monitor circuits activate trickle charge preconditioning, battery present detection and C/10 current detection. This pin is in a high impedance state when  $V_{CC}$  is below the undervoltage lockout threshold. During trickle charge preconditioning and charging the BAT pin sources 12mA and 1.3mA respectively. The current sources are clamped from driving the BAT pin above 4.5V/cell with an internal pull-down transistor.

In the No Bat, Done and Pause states or the Hold and Reset modes, the current sources are turned off, leaving only the 55k OVP divider as a load on the BAT pin. Most chargers have a 200 $\mu$ A current source that will compensate for this 50 $\mu$ A to 80 $\mu$ A load.

**SENSE (Pin 3):** Input to C/10 Current Detection Circuit. This pin sinks 100 $\mu$ A during the Charge state which is used to program the C/10 current threshold.

**GND (Pin 4):** Ground.

**NTC (Pin 5):** Input to the NTC Thermistor Monitoring Circuits. When the voltage on this pin is above 2.79V (cold) or below 0.405V (hot), the state machine is locked in the present state and the timer is stopped. This is called the Hold mode. While in the Hold mode, the charger is turned off via the  $V_C$  pin and the current sources on BAT and SENSE pins are turned off. The STATUS pin is not affected.

If the NTC pin is below 0.2V, the state machine is forced in the reset mode with all the timers cleared to zero. The current sources on the BAT pin and SENSE pin are disabled leaving the 55k OVP divider. The STATUS pin is pulled low in the Reset mode.

There is a 100 $\mu$ A current source on the NTC pin to bias the NTC thermistor. This current source is active when the  $V_{CC}$  is greater than the undervoltage lockout threshold.

**STATUS (Pin 6):** Open-Drain Output for C/10 Charge Termination Detection Circuit. When in the Charge state, this pin is pulled low. Once the charge current drops below the C/10 current threshold for three seconds, the pull-down transistor is disabled, and a 50 $\mu$ A pull-down current sink remains activated until the 1- or 3-hour time-out or the battery or wall adapter is removed.

**$V_C$  (Pin 7):** Open-Drain Output for Turning Off the Charger. When this pin is open circuit, the charger is active. Normally this pin allows the charger to be active for three hours.

**$V_{CC}$  (Pin 8):** Input Supply. For 4.1V or 4.2V single cell operation,  $V_{CC}$  should be between 8V and 28V with the IC turning off when  $V_{CC}$  drops below 6V. For 2-cell applications, the undervoltage lockout is 10.4V with a minimum  $V_{CC}$  of 12V. Removing the wall adapter will trigger an undervoltage lockout and put the IC in a high impedance condition. When the supply is connected, the IC is initialized in the Reset mode with the state machine forced in the Charge state with all the timers set to zero.

**BLOCK DIAGRAM**

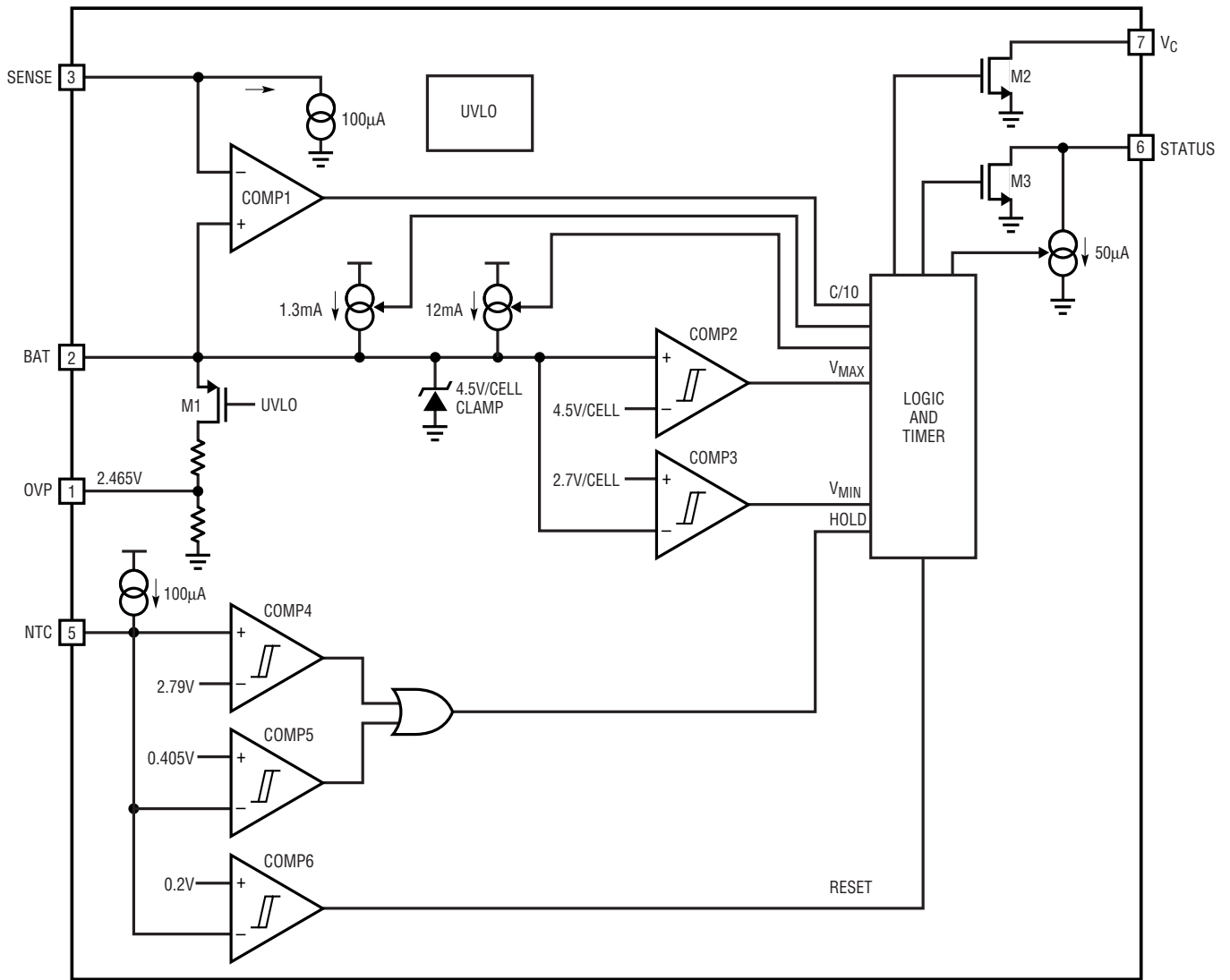

1729 F02

Figure 2. Block Diagram

## APPLICATIONS INFORMATION

### Overview

The LTC1729 is a charge termination controller for the LT1505/LT1510/LT1511/LT1512/LT1513/LT1769 constant-voltage/constant-current battery charger family. Table 1 details these chargers. The primary function of this IC is to stop the charger after three hours of constant-voltage/constant-current charging. The secondary function of this controller includes an indication when the charge current (during constant-voltage mode) drops below a user-selected threshold. A 500kHz Li-Ion cell phone charger is shown in Figure 1. The LTC1729 requires only six external components when combined with the standard LT1510 application. The LTC1729 provides a complete and tiny solution for cellular phones and other portable applications.

**Table 1. Battery Chargers**

LT1505	4A Step-Down Charger with Input Current Limit
LT1510	1.5A Step-Down Charger
LT1510-5	1.5A 500kHz Step-Down Charger
LT1511	3A Step-Down Charger with Input Current Limit
LT1512	2A Switch SEPIC Charger
LT1513	3A Switch SEPIC Charger
LT1769	2A Step-Down Charger with Input Current Limit

### Block Diagram

Figure 2 shows the block diagram of the LTC1729. The IC consists of six comparators, a resistive divider, a UVLO block and a logic and timer block.

Comparator COMP1 is used to indicate **C**/10 charge current threshold. (“**C**” is a term used to indicate the Ampere-hour capacity of a cell.) Figure 3 details the **C**/10 detection circuit. The resistor and capacitor on the SENSE pin filter the signal from the 0.2Ω current sense resistor R1. The 100μA current sink on the SENSE pin develops 20mV across the 200Ω resistor R2. This sets a 20mV offset on COMP1 that sense resistor R1 must equal before **C**/10 current is indicated. The **C**/10 is not recognized by the logic until it passes through a 3-second digital filter.

For cases where there are multiple batteries to be charged, the LTC1729 detects when a battery is removed and resets the timers for the next charge cycle. The battery present detection is the primary function of comparator COMP2. When the battery is disconnected from the LTC1729, the voltage at the BAT pin will begin ramping upward. This is due to a current source inside the charger or an external pull-up resistor. Once the voltage on the BAT pin exceeds the 4.5V/cell limit, COMP2 signals a  $V_{MAX} = \text{true}$  to the logic and turns on a transistor that clamps the voltage.

There is the possibility of an overvoltage transient at the charging terminals. This occurs if the battery protection circuit, which is often included in the battery pack, opens the connection to the battery during high current charging (constant-current mode). This is a result of energy storage in the inductor. COMP2 senses the overvoltage and clamps the  $V_C$  pin, reducing the duty cycle of the charger. If the battery protection circuit quickly returns battery connection to the charger (in less than one second), then the LTC1729 continues charging without resetting the timers.

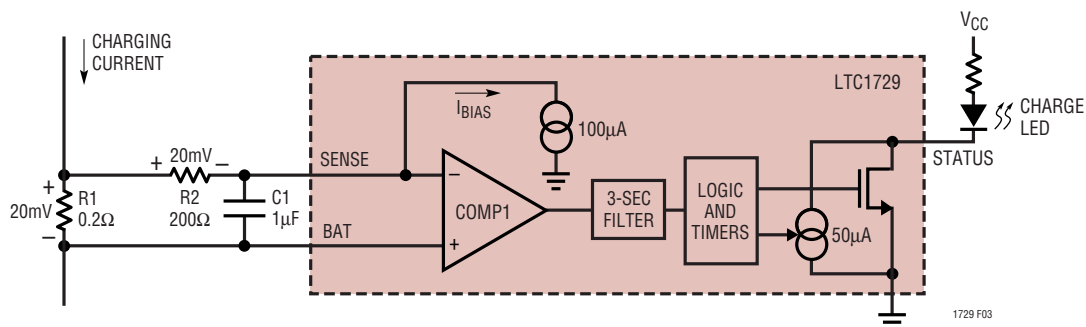

**Figure 3. C/10 Detection Circuit**

## APPLICATIONS INFORMATION

For a battery that has been deeply discharged, the LTC1729 provides a 12mA start-up current. This preconditioning trickle charge begins when the battery voltage drops below 2.7V/cell. Comparator COMP3 is used to determine when this condition exists. The battery operating range is summarized in Figure 4.

With a 10k negative TC thermistor connected to the NTC pin, the LTC1729 will disable charging if the temperature is not in the 0°C to 50°C range. A thermistor must be present at this pin, or if the temperature qualification feature is not used, a 10k resistor must be used in its place. This pin should not be left open. The NTC thermistor monitoring circuits consist of COMP4, COMP5 and COMP6. The NTC pin voltage range is shown in Figure 5.

Comparators COMP4 and COMP5 signal the logic when the temperature is below 0°C or above 50°C. The 100µA bias current through the 10kΩ thermistor will generate 2.79V at 0°C and 0.405V at 50°C. The voltage hysteresis on COMP4 and COMP5 is designed to give 10°C of temperature hysteresis. If the voltage on the NTC pin drops below 0.2V, the comparator COMP6 generates a reset to the logic and timer block.

To provide accurate charge voltages, the internal resistor divider is trimmed to provide a precise ±0.2% voltage of 2.465V at the OVP pin for the four battery voltage options of 4.1V, 4.2V, 8.2V and 8.4V.

When the input supply is removed in step-down charger designs, the V<sub>CC</sub> pin does not drop to 0V, but is held to a diode drop below the battery voltage. This is due to the internal parasitic diode from the SW pin to the V<sub>CC</sub> pin that is present in the LT1510, LT1511, LT1769, and the body diode of the top MOSFET in the LT1505 charger. Removing the input supply will result in the V<sub>CC</sub> pin dropping below the UVLO threshold, thus shutting down the LTC1729 and minimizing battery drain. Once the input supply is connected, the LTC1729 resets the timers and begins another charge cycle. There is a disconnect transistor that will remove the OVP resistor divider from the battery when the V<sub>CC</sub> voltage drops below the UVLO threshold.

If external circuitry is connected directly to the V<sub>CC</sub> pin and the input power is removed, battery current will flow through the charger's internal parasitic diode (SW pin to V<sub>CC</sub> pin), discharging the battery and possibly damaging the charger if currents greater than 1A are present. If external circuitry is used, connect it directly to the input power source (which is the anode of the input Schottky diode).

The logic and timer block consists of a state machine, oscillator and counter. The state machine will be discussed in detail in the next section. The oscillator is internally trimmed to 131kHz. The counter is composed of a chain of 25 flip-flops that includes self-test circuitry.

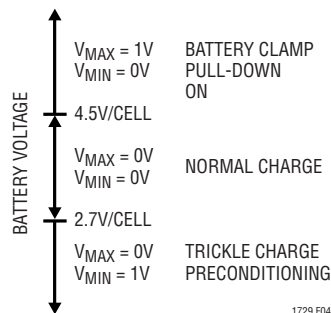

Figure 4. BAT Voltage Operating Range

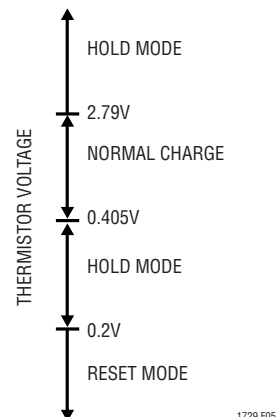

Figure 5. NTC Voltage Operating Range

## APPLICATIONS INFORMATION

### State Machine

The state machine is responsible for the following items:

1. When to start and stop the charger. The internal timer must be initialized every time a new battery is installed or when the input supply is applied.
2. When a battery is installed, the state machine must determine if it is a new battery or if the previous battery has been reinstalled.
3. When a deeply discharged battery is installed, trickle charge conditioning must take place before the full charge current.

The state machine diagram is shown in Figure 6. Note that the Charge state includes the Precondition state, the charger “ON” state and the Reset mode.

Reset and Hold are the two modes that will cause the charger to stop charging ( $V_C$  pin pulled low) and ignore the state machine. The Reset mode clears all the timers and forces the state machine to begin in the Charge state (STATUS pin pulled low). This mode is only activated momentarily at power-up or when the NTC pin is below the Reset threshold. The other interrupt condition is called the Hold mode. When the voltage on the NTC pin is above 2.79V (cold) or below 0.405V (hot), the state machine is locked in the present state until the NTC pin voltage returns to the proper range. While in the Hold mode, the charging is disabled and the timers are frozen.

The charger is enabled only during the charger “ON” state. There are three ways that the state machine can exit the charger “ON” state. The first is for a 3-hour time-out which is denoted as the time  $> t_{MAX}$  transition to the Done state.

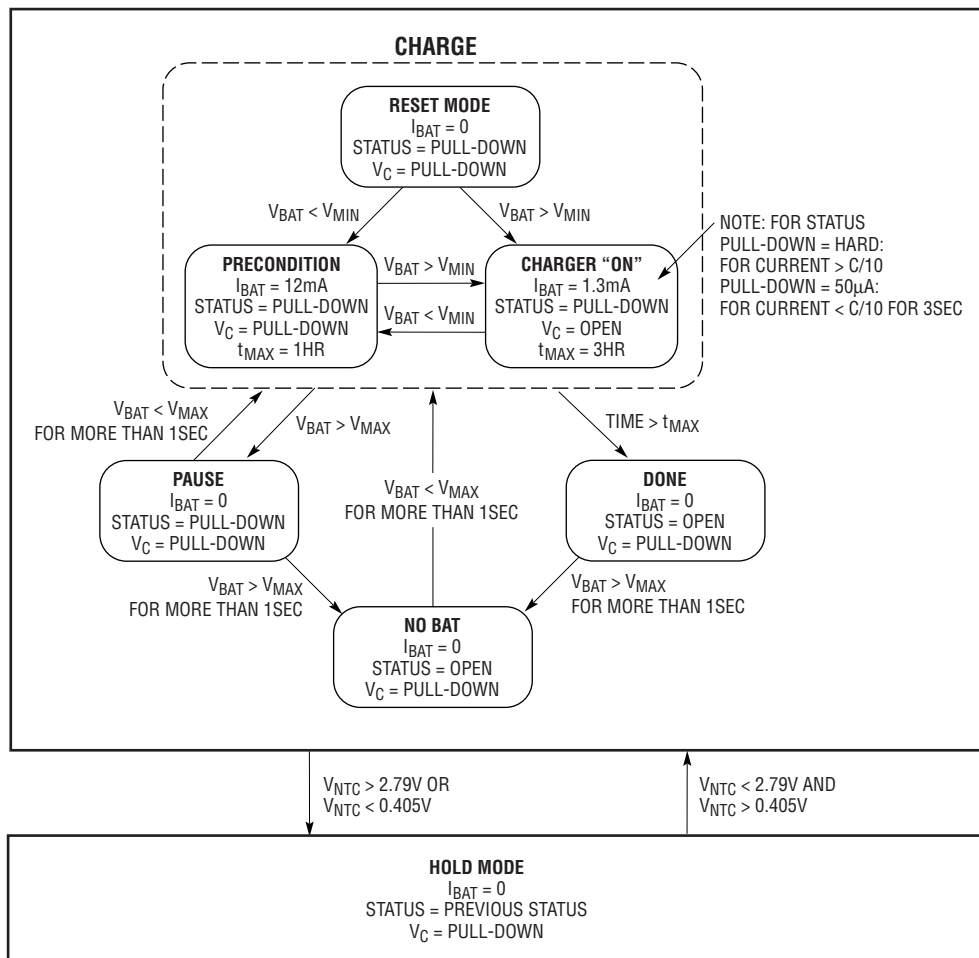

1729 F06

Figure 6. State Diagram

## APPLICATIONS INFORMATION

Second, if the battery is removed from the charger, the  $V_{MAX}$  signal is activated as mentioned in the Block Diagram section. This causes the state machine to make the  $V_{BAT} > V_{MAX}$  transition to the Pause state. The third way to exit the charger “ON” state is with a  $V_{BAT} < V_{MIN}$  transition to the Precondition state. The battery will need to drop below 2.6V/cell to be less than  $V_{MIN}$ . This is not a likely scenario.

Once in the Pause state, there are two ways to proceed. The first is to go to the No Bat state. This requires that the  $V_{BAT}$  remain greater than  $V_{MAX}$  for more than one second. From these conditions, the LTC1729 interprets that a battery has been removed. If the voltage on the BAT pin stays less than  $V_{MAX}$  for more than one second, then the state machine returns to the Charge state (Precondition and charger “ON”). This is interpreted as a momentary open caused by the battery pack protection circuitry or loose contact.

The Done state can only proceed to the No Bat state. From outside the LTC1729 this transition is undetectable. The requirement for this transition is for the BAT pin voltage to exceed  $V_{MAX}$  for more than one second. The IC now assumes that the battery has been removed.

From the No Bat state, there is only one possible transition. The No Bat state can move to the Charge state if the voltage on the BAT pin remains less than  $V_{MAX}$  for one second. The LTC1729 will now work on the assumption that a new battery has been installed.

Although the Precondition and Charger “ON” both reside in the Charge state, there are differences between these states. The main purpose of the Precondition state is to slowly bring a heavily discharged battery up to a minimum level before full charge current begins. The Precondition state uses a 12mA current source to trickle charge the battery with a 1-hour time-out transition to the Done state. The Charger “ON” state enables the external charger and the time-out is increased to three hours. For the entire time in the Precondition state, the STATUS pin uses a hard pull-down. In the Charger “ON” state the STATUS pin uses two types of pull-down: hard pull-down and soft 50 $\mu$ A pull-down.

### Status Output Pin

The STATUS pin is designed to provide an indication that the battery is charging. Once the current drops below the **C/10** threshold, the battery is close to being fully charged. The LTC1729 turns off the hard pull-down once the **C/10** comparator is active for more than three seconds. The 50 $\mu$ A soft pull down remains in effect until the 3-hour time-out is completed or the input power is removed.

By using two different value pull-up resistors, a microprocessor can detect three states from this pin (charging, **C/10** and stop charging). See Figure 7.

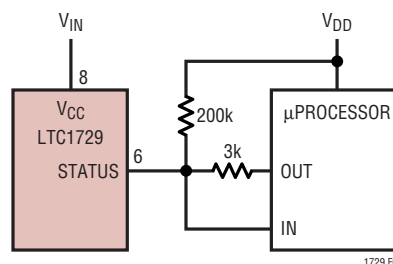

Figure 7. Microprocessor Interface

When the LTC1729 is in charge mode, the STATUS pin is pulled down by an internal N-channel MOSFET. To detect this mode, force the digital output pin, OUT, high and measure the voltage at the STATUS pin. The N-channel MOSFET will pull the pin low even with a 3k pull-up resistor. Once the charge current drops to 10% of the full-scale current (**C/10**), the N-channel MOSFET is turned off and a 50 $\mu$ A current source is connected to the STATUS pin. The IN pin will then be pulled high by the 3k pull-up. By forcing the OUT pin into a high impedance state, the current source will pull the pin low through the 200k resistor. When the internal timer has expired, the STATUS pin will change to high impedance state and the 200k resistor will then pull the pin high to indicate the charging has stopped.

### Terminate at **C/10** Current

Charging can also be terminated using **C/10** detection before the 3-hour time-out. By connecting the low side of the NTC thermistor to the STATUS pin instead of ground,

## APPLICATIONS INFORMATION

the NTC pin will float to 5V as soon as the Status pull-down is open. This will force the state machine into the Hold mode. The  $V_C$  pin is pulled low which turns off the charger. This circuit is shown in Figure 8.

In order to restart the charging process for a new battery, the NTC pin will need to be momentarily brought below 0.2V or the  $V_{CC}$  pin brought below the UVLO threshold. The automatic battery detection features are disabled during the Hold mode.

### Using Status as a Charging Indicator

In many applications circuits shown in this data sheet, the STATUS pin is used to indicate when C/10 has occurred (charge current has dropped to 10% of the full charge

current). This C/10 number is not fixed, but is set by an external resistor connected to the LTC1729 SENSE pin. A 100 $\mu$ A bias current through this resistor develops a voltage which is compared with the voltage across the charge current sense resistor. When these voltages are equal, the open-drain STATUS pin turns off. Connecting an LED to the STATUS pin will give a visual indication during the precondition trickle charge and the portion of the main charge before C/10 has occurred.

By reducing the LTC1729 SENSE pin resistor to 0 $\Omega$ , the STATUS pin function can be changed to a *charging indicator* (Figure 9). The LED on the STATUS pin will always go off after the 3-hour charge cycle is completed, regardless of the C/10 circuitry.

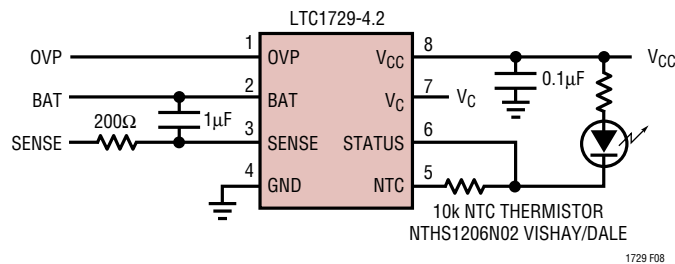

Figure 8. Terminate Charging at C/10

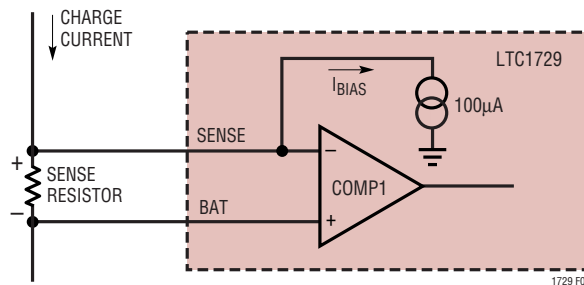
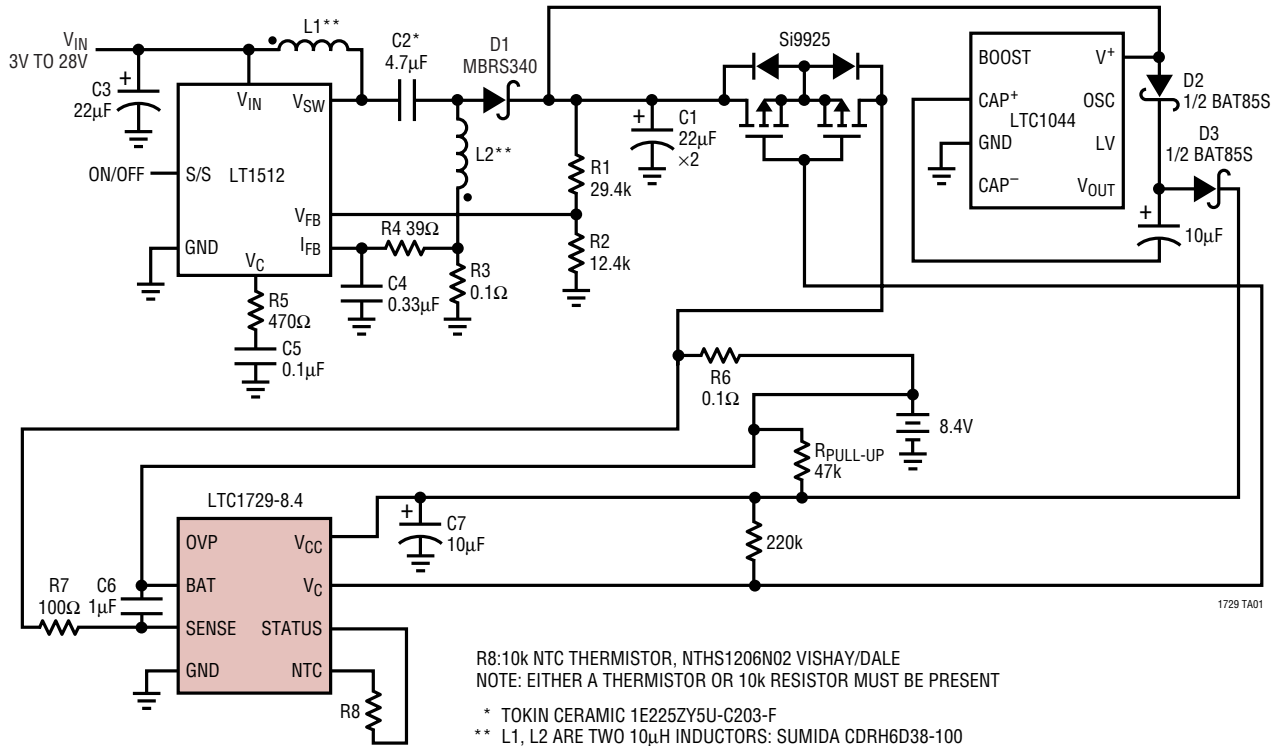

Figure 9. Modify C/10 Indication to Create Charging Indicator

**TYPICAL APPLICATIONS**

**Wide Input Voltage Range 1A Charger**



**Using STATUS Pin to Indicate Charge Status**

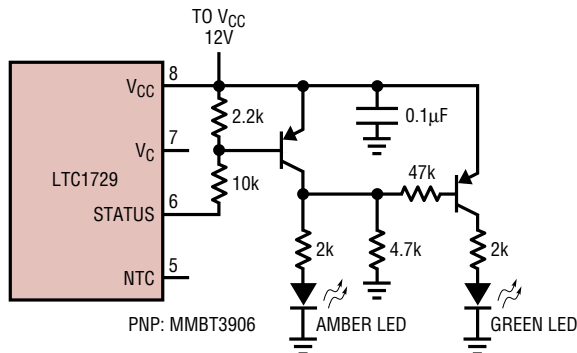

CONDITION	AMBER	GREEN
NO WALL ADAPTER	OFF	OFF
CHARGING ( $I_{BAT} > C/10$ )	ON	OFF
CHARGING ( $I_{BAT} < C/10$ )	OFF	ON
TIMER EXPIRED	OFF	ON

1729 TA03

TYPICAL APPLICATIONS

4A, 2-Cell Lithium-Ion Battery Charger

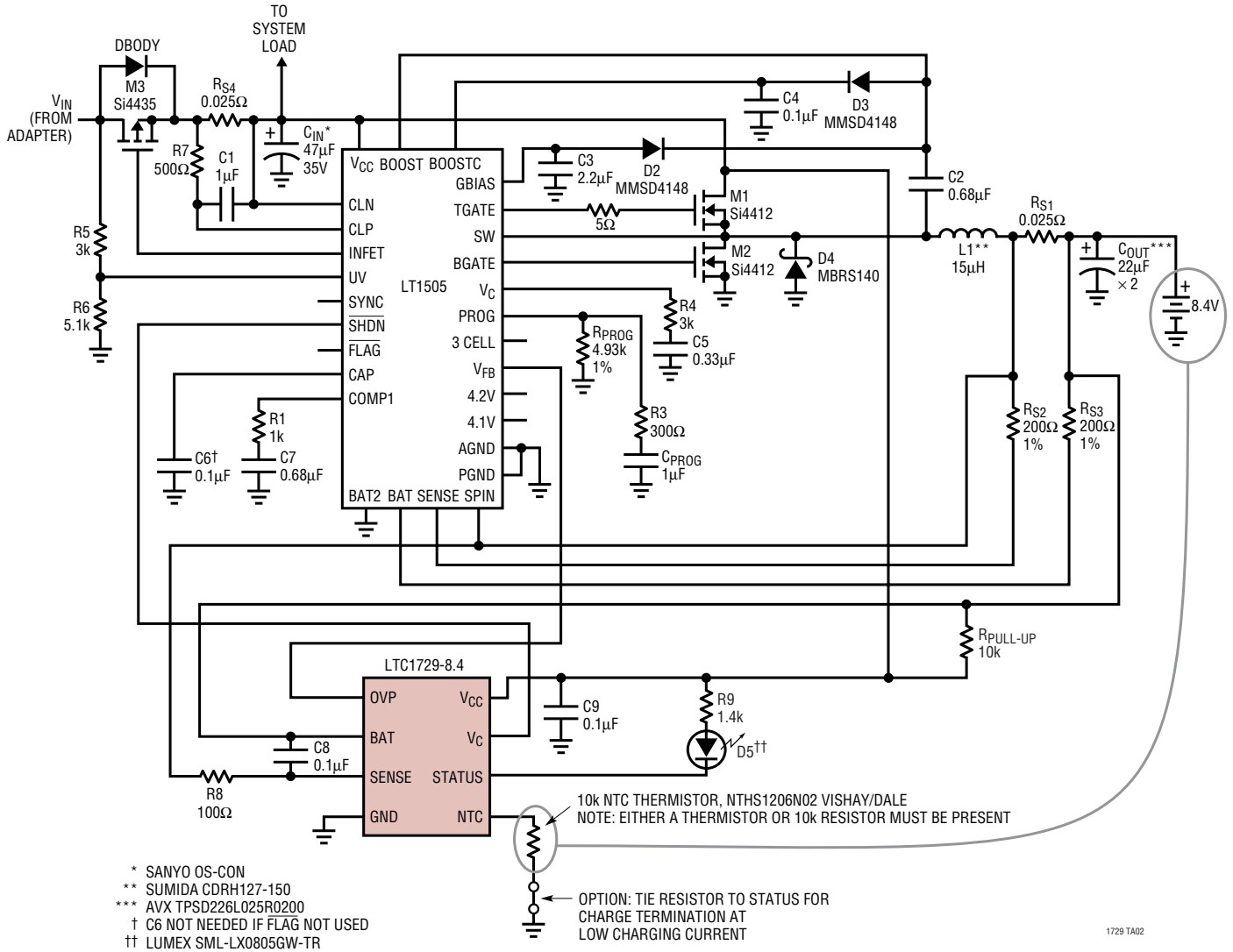

**PACKAGE DESCRIPTION** Dimensions in inches (millimeters) unless otherwise noted.

**MS8 Package**  
**8-Lead Plastic MSOP**  
 (LTC DWG # 05-08-1660)

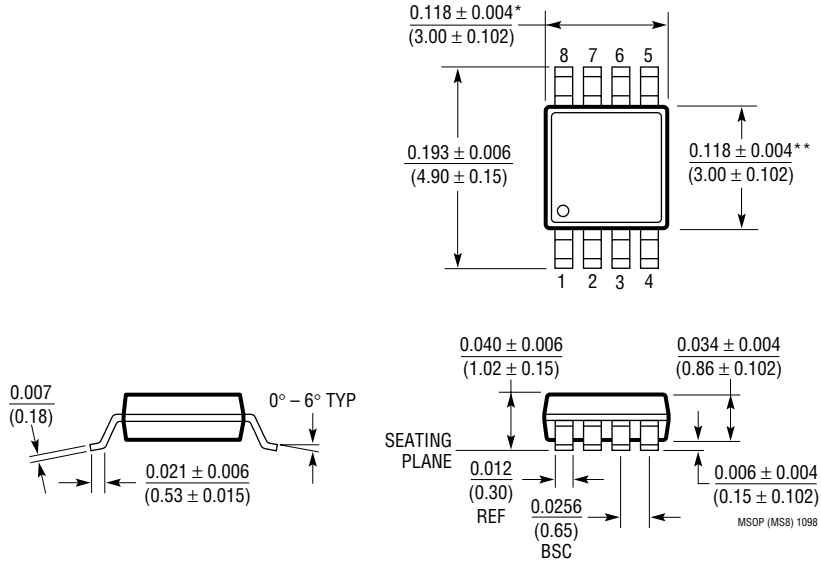

\* DIMENSION DOES NOT INCLUDE MOLD FLASH, PROTRUSIONS OR GATE BURRS. MOLD FLASH, PROTRUSIONS OR GATE BURRS SHALL NOT EXCEED 0.006\* (0.152mm) PER SIDE

\*\* DIMENSION DOES NOT INCLUDE INTERLEAD FLASH OR PROTRUSIONS. INTERLEAD FLASH OR PROTRUSIONS SHALL NOT EXCEED 0.006\* (0.152mm) PER SIDE

**PACKAGE DESCRIPTION** Dimensions in inches (millimeters) unless otherwise noted.

**S8 Package**  
**8-Lead Plastic Small Outline (Narrow 0.150)**  
 (LTC DWG # 05-08-1610)

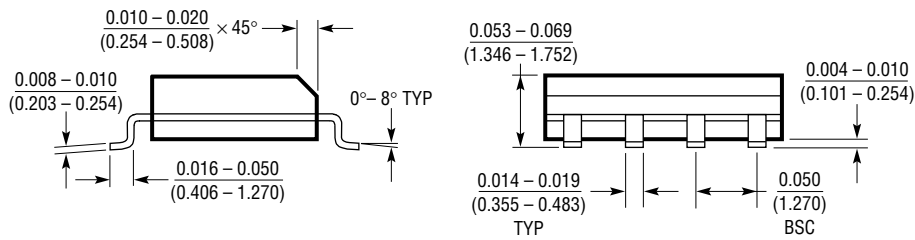
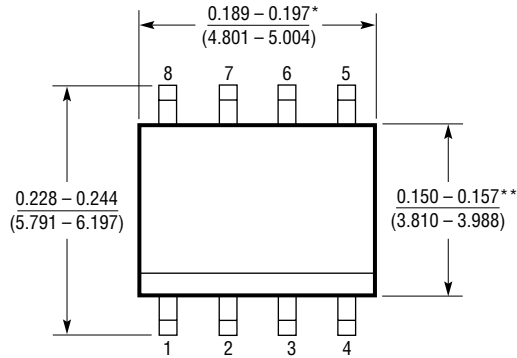

\*DIMENSION DOES NOT INCLUDE MOLD FLASH. MOLD FLASH SHALL NOT EXCEED 0.006" (0.152mm) PER SIDE  
 \*\*DIMENSION DOES NOT INCLUDE INTERLEAD FLASH. INTERLEAD FLASH SHALL NOT EXCEED 0.010" (0.254mm) PER SIDE

S08 1298

## TYPICAL APPLICATION

### 3A (LT1511) Or 2A (LT1769), 2-Cell Lithium-Ion Battery Charger

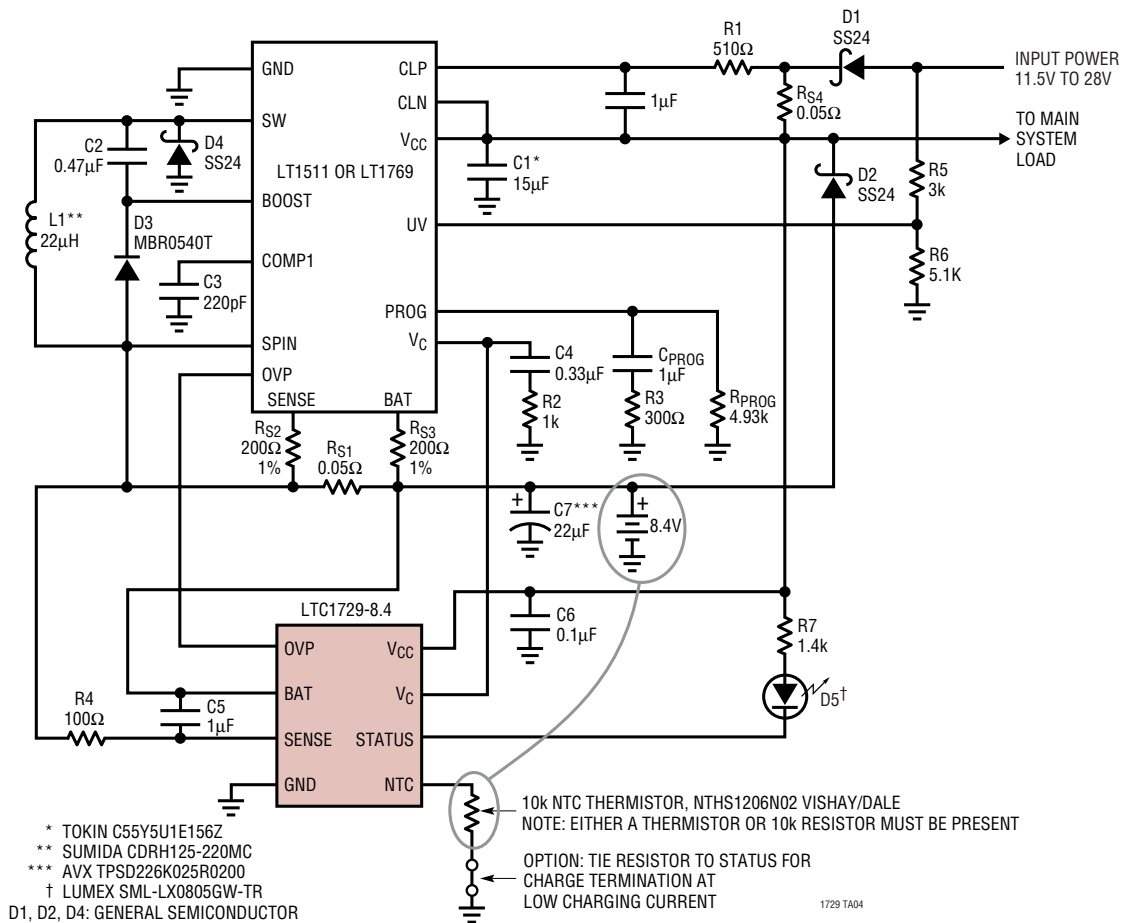

## RELATED PARTS

PART NUMBER	DESCRIPTION	COMMENTS
LT1505	High Efficiency Constant-Voltage/Constant-Current Battery Charger	Uses External Synchronous N-Channel FETs
LT1510	Constant-Voltage/Constant-Current Battery charger	Up to 1.5A Charge Current for Lithium-Ion, NiCd and NiMH Batteries, Internal R <sub>SENSE</sub>
LT1511	3A Constant-Voltage/Constant-Current Battery Charger	Charges Lithium, NiCd and NiMH Batteries
LT1512	SEPIC Battery Charger	V <sub>IN</sub> Can Be Higher or Lower Than Battery Voltage, 2A Switch
LT1513	SEPIC Battery Charger	V <sub>IN</sub> Can Be Higher or Lower Than Battery Voltage, 3A Switch
LT1571-1/LT1571-2 LT1571-5	200kHz/500kHz Constant-Current/Constant-Voltage Battery Charger Family	Up to 1.5A Charge Current for 1- or 2-Cell Li-Ion Batteries, Preset and Adjustable Battery Voltages, C/10 Charge Detection
LTC1731	Linear Charger	Programmable Timer, C/10 Flag, 8-Pin MSOP
LTC1732	Linear Charger	Programmable Timer, C/10 Flag, AC Power Good, 10-Pin MSOP
LTC1759	SMBus-Controlled Smart Battery Charger	LT1505 Charger Functionality with SMBus Control
LT1769	2A Constant-Voltage/Constant-Current Battery Charger	28-Pin SSOP Package

## Looking for pricing, stock, or lifecycle information?

Click below to explore more details on WIN SOURCE:

- ⊖ [View LTC1729CMS8-4.1#PBF](#) on WIN SOURCE
- ⊖ [Linear Technology](#) Information

## Optimize Your Supply Chain with WIN SOURCE Solutions

- ✓ Global Sourcing Solution
- ✓ Obsolete Management
- ✓ Cost Control Management
- ✓ Shortage Management
- ✓ Alternative Solution
- ✓ Excess Inventory Management