



**THE DATASHEET OF
LTC1565-31CS8#TRPBF**



650kHz Continuous Time, Linear Phase Lowpass Filter

FEATURES

- 7th Order, 650kHz Linear Phase Filter in an SO-8
- Differential Inputs and Outputs
- Operates on a Single 5V or a $\pm 5V$ Supply
- Low Offset: 5mV Typical
- 75dB THD and SNR
- 78dB SNR
- Shutdown Mode
- Requires No External Components
- Requires No External Clock Signal

APPLICATIONS

- CDMA Basestations
- Data Communications
- Antialiasing Filters
- Smoothing or Reconstruction Filters
- Matched Filter Pairs
- Replacement for LC Filters

DESCRIPTION

The LTC[®]1565-31 is a 7th order, continuous time, linear phase lowpass filter. The selectivity of the LTC1565-31, combined with its linear phase and dynamic range, make it suitable for filtering in data communications or data acquisition systems. The filter attenuation is 36dB at $2 \times f_{\text{CUTOFF}}$ and at least 72dB for frequencies above $3 \times f_{\text{CUTOFF}}$. Unlike comparable LC filters, the LTC1565-31 achieves this selectivity with a linear phase response in the passband.

With 5% accuracy of the cutoff frequency, the LTC1565-31 can be used in applications requiring pairs of matched filters, such as transceiver I and Q channels. Furthermore, the differential inputs and outputs provide a simple interface for these wireless systems.

With a single 5V supply and a $2V_{\text{P-P}}$ input, the LTC1565-31 features an impressive spurious free dynamic range of 75dB. The maximum signal-to-noise ratio is 78dB and it is achieved with a $2.5V_{\text{P-P}}$ input signal.

The LTC1565-31 features a shutdown mode where power supply current is typically less than 10 μ A.

For W-CDMA, 3G, CDMA 2000 and other cellular and noncellular cutoff frequencies or single-ended I/O, please contact LTC Marketing for additional information.

LT, LT, LTC, LTM, Linear Technology and the Linear logo are registered trademarks of Linear Technology Corporation. All other trademarks are the property of their respective owners.

TYPICAL APPLICATION

Single 5V Supply, Differential 650kHz Lowpass Filter

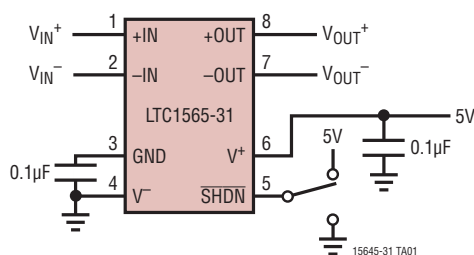

Frequency Response

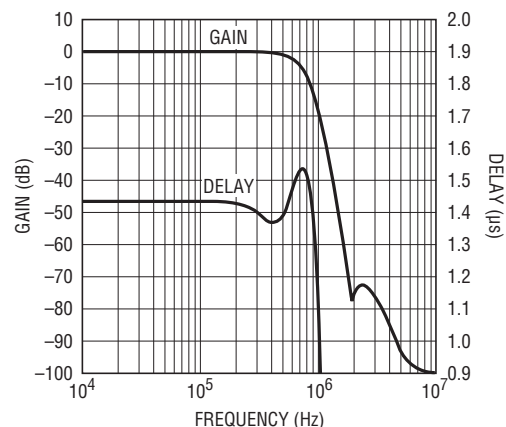

1565 G01

156531fa

LTC1565-31

ABSOLUTE MAXIMUM RATINGS

(Note 1)

Total Supply Voltage	11V
Power Dissipation	500mW
Operating Temperature Range	
LTC1565-31CS8	0°C to 70°C
LTC1565-31IS8	-40°C to 85°C
Storage Temperature Range	-65°C to 150°C
Lead Temperature (Soldering, 10 sec)	300°C

PIN CONFIGURATION

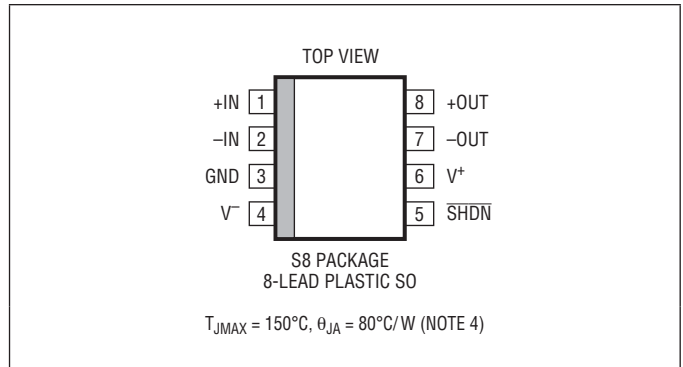

ORDER INFORMATION

LEAD FREE FINISH	TAPE AND REEL	PART MARKING	PACKAGE DESCRIPTION	TEMPERATURE RANGE
LTC1565-31CS8#PBF	LTC1565-31CS8#TRPBF	156531	8-Lead Plastic SO	0°C to 70°C
LTC1565-31IS8#PBF	LTC1565-31IS8#TRPBF	565311	8-Lead Plastic SO	-40°C to 85°C

Consult LTC Marketing for parts specified with wider operating temperature ranges.

Consult LTC Marketing for information on non-standard lead based finish parts.

For more information on lead free part marking, go to: <http://www.linear.com/leadfree/>

For more information on tape and reel specifications, go to: <http://www.linear.com/tapeandreeel/>

ELECTRICAL CHARACTERISTICS

The ● denotes the specifications which apply over the full operating temperature range, otherwise specifications are at $T_A = 25^\circ\text{C}$. $V_S = 5\text{V}$, $R_{LOAD} = 10\text{k}$ from each output to AC ground, and Pin 5 open unless otherwise specified.

PARAMETER	CONDITIONS	MIN	TYP	MAX	UNITS
Operating Supply Voltage		4.75		11	V
Filter Gain	$V_{IN} = 1V_{P-P}$ $f_{IN} = 25\text{kHz}$ $f_{IN} = 200\text{kHz}$ (Gain Relative to 25kHz) $f_{IN} = 300\text{kHz}$ (Gain Relative to 25kHz) $f_{IN} = 500\text{kHz}$ (Gain Relative to 25kHz) $f_{IN} = 650\text{kHz}$ (Gain Relative to 25kHz) $f_{IN} = 900\text{kHz}$ (Gain Relative to 25kHz) $f_{IN} = 1.3\text{MHz}$ (Gain Relative to 25kHz) $f_{IN} = 2.3\text{MHz}$ (Gain Relative to 25kHz)	● ● ● ● ● ● ● ●	-0.3 0 -0.4 -1.6 -3 -11 -36 -72	0.3 0.1 -0.1 -0.95 -2 -7 -31	dB dB dB dB dB dB dB dB
Filter Phase	$V_{IN} = 1V_{P-P}$ $f_{IN} = 25\text{kHz}$ $f_{IN} = 200\text{kHz}$ $f_{IN} = 300\text{kHz}$ $f_{IN} = 500\text{kHz}$ $f_{IN} = 600\text{kHz}$ $f_{IN} = 650\text{kHz}$ $f_{IN} = 900\text{kHz}$	● ●	-13 -101 -162 113 34 36 -92	-138 85	Deg Deg Deg Deg Deg Deg Deg
Phase Linearity	Ratio of 600kHz Phase/300kHz Phase	●	1.95	2	2.03
Wideband Noise	Noise BW = DC to $2 \cdot f_{CUTOFF}$			118	μV_{RMS}
THD	$f_{IN} = 100\text{kHz}$, $1V_{P-P}$ (Note 2)			86	dB
Filter Differential DC Swing	Maximum Difference Between Pins 7 and 8 $V_S = 5\text{V}$ $V_S = \pm 5\text{V}$	● ●	± 1.4 ± 2.2	± 1.7 ± 2.3	V V

156531fa

ELECTRICAL CHARACTERISTICS

The ● denotes the specifications which apply over the full operating temperature range, otherwise specifications are at $T_A = 25^\circ\text{C}$. $V_S = 5\text{V}$, $R_{\text{LOAD}} = 10\text{k}$ from each output to AC ground, and Pin 5 open unless otherwise specified.

PARAMETER	CONDITIONS	MIN	TYP	MAX	UNITS	
Input Bias Current		0.1	0.3	0.6	μA	
Input Offset Current			± 10		nA	
Input Resistance	Common Mode, $V_{\text{IN}} = 2.5\text{V}$ Differential		75 145		$\text{M}\Omega$ $\text{M}\Omega$	
Input Capacitance			3		pF	
Output DC Offset (Note 3)	$V_S = 5\text{V}$ $V_S = \pm 5\text{V}$ (Note 5)		± 5 ± 5	± 12 ± 12	mV mV	
Output DC Offset Drift	$V_S = 5\text{V}$ $V_S = \pm 5\text{V}$		-400 -400		$\mu\text{V}/^\circ\text{C}$ $\mu\text{V}/^\circ\text{C}$	
Ground Voltage (Pin 3) in Single Supply Applications	$V_S = 5\text{V}$	●	2.49	2.51	2.52	V
SHDN Pin Logic Thresholds	$V_S = 5\text{V}$, Minimum Logical "1" $V_S = 5\text{V}$, Maximum Logical "0"	●	3.3	4.2	V	
	$V_S = \pm 5\text{V}$, Minimum Logical "1" $V_S = \pm 5\text{V}$, Maximum Logical "0"	●				
SHDN Pin Pull-Up Current	$V_S = 5\text{V}$ $V_S = \pm 5\text{V}$		5 9		μA μA	
	$V_S = 5\text{V}$ $V_S = \pm 5\text{V}$	●	24 25	31 33	mA mA	
Power Supply Current in Shutdown Mode	Shutdown. Includes SHDN Pull-Up Current $V_S = 5\text{V}$ $V_S = \pm 5\text{V}$	●	8 20	16 40	μA μA	

Note 1: Stresses beyond those listed under Absolute Maximum Ratings may cause permanent damage to the device. Exposure to any Absolute Maximum Rating condition for extended periods may affect device reliability and lifetime.

Note 2: Input and output voltages expressed as peak-to-peak numbers are assumed to be fully differential.

Note 3: Output DC offset is measured between Pin 8 and Pin 7 with Pin 1 and Pin 2 connected to Pin 3.

Note 4: Thermal resistance varies depending upon the amount of PC board metal attached to the device. θ_{JA} is specified for a 3.8 square inch test board covered with 2 oz copper on both sides.

Note 5: Output DC offset measurements are performed by automatic test equipment approximately 0.5 seconds after application of power.

TYPICAL PERFORMANCE CHARACTERISTICS

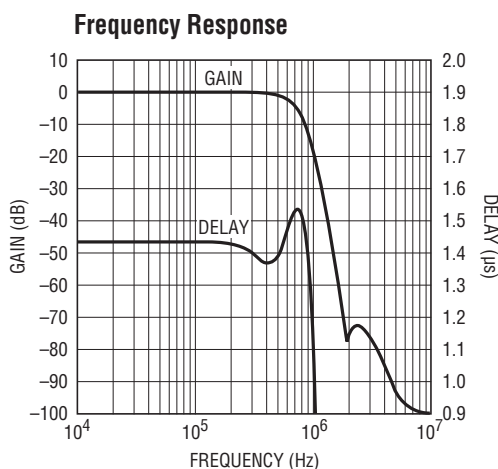

1565 G01

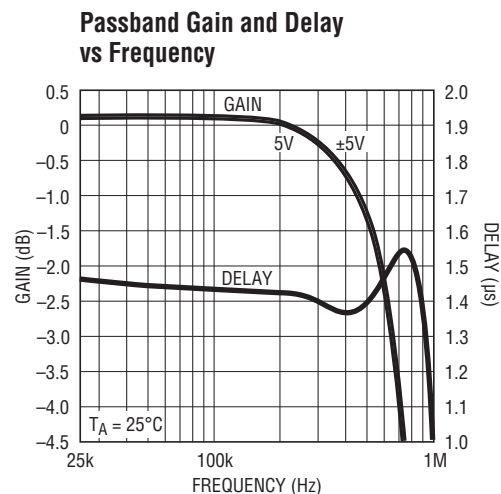

1565 G02

156531fa

TYPICAL PERFORMANCE CHARACTERISTICS

Passband Gain vs Frequency Over Temperature

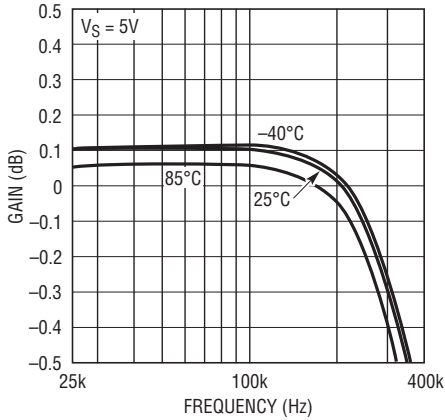

1565 G03

Stopband Gain vs Frequency

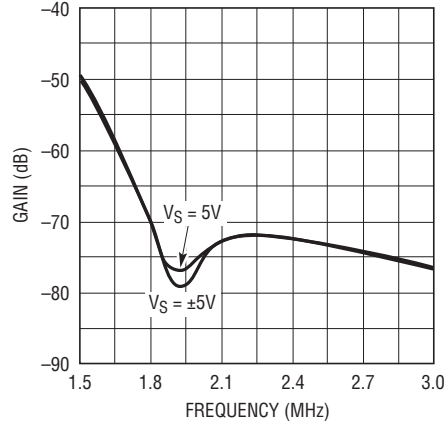

1565 G04

Stopband Gain vs Frequency Over Temperature

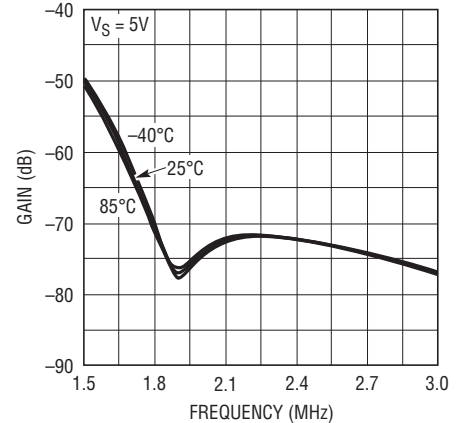

1565 G05

Common Mode Rejection Ratio

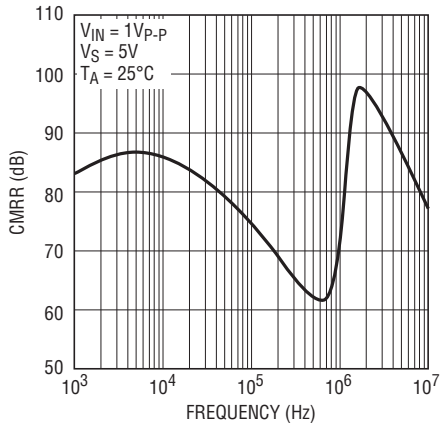

1565 G06

Power Supply Rejection Ratio

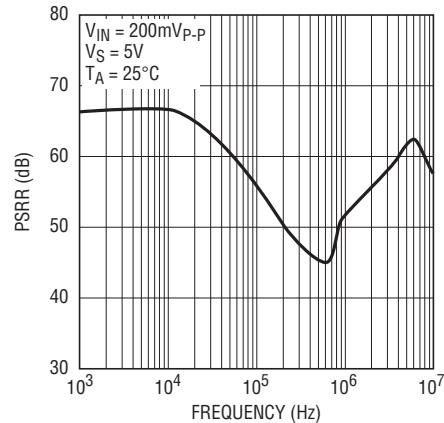

1565 G07

Supply Current vs Temperature

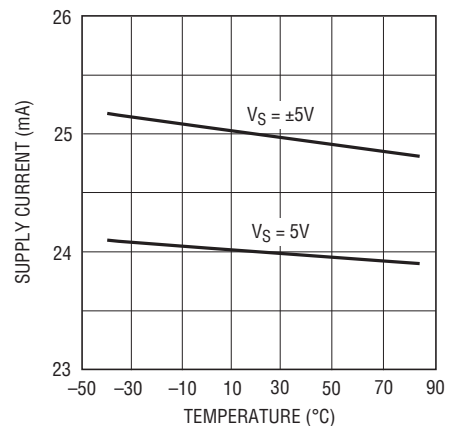

1565 G08

PIN FUNCTIONS

+IN, -IN (Pins 1, 2): Input Pins. Signals can be applied to either or both input pins. The typical DC gain from differential inputs (Pin 1 to Pin 2) to the differential outputs (Pin 8 to Pin 7) is 1.0V/V. The input range is described in the Applications Information section.

GND (Pin 3): Ground. The ground pin is the reference voltage for the filter and is internally biased to one-half the total power supply voltage of the filter, maximizing the dynamic range of the filter. For single supply operation, the ground pin should be bypassed with a quality 0.1 μ F

ceramic capacitor to Pin 4. For dual supply operation, connect Pin 3 to a high quality DC ground. A ground plane should be used. A poor ground will increase noise and distortion.

The impedance seen at Pin 3 is 2.5k Ω in normal mode. In shutdown, the pin is internally biased to the same levels as normal mode. The impedance in shutdown mode is typically 500k Ω but varies with supply voltage and temperature.

PIN FUNCTIONS

V⁻, V⁺ (Pins 4, 6): Power Supply Pins. For a single 5V supply (Pin 4 grounded), a quality 0.1 μ F ceramic bypass capacitor is required from the positive supply pin (Pin 6) to the negative supply pin (Pin 4). The bypass should be as close as possible to the IC. For dual supply applications (Pin 3 is grounded), bypass Pin 6 to Pin 3 and Pin 4 to Pin 3 with a quality 0.1 μ F ceramic capacitor.

The maximum voltage difference between the ground pin (Pin 3) and the positive supply pin (Pin 6) should not exceed 5.5V.

SHDN (Pin 5): Shutdown. When the Pin 5 voltage is low, the LTC1565-31 goes into the current saving shutdown mode. Pin 5 has a 4 μ A pull-up current. Leaving Pin 5 open will place the LTC1565-31 in its normal operating mode.

-OUT, +OUT (Pins 7, 8): Output Pins. Pins 7 and 8 are the filter differential output. Each pin can drive 1k Ω or 300pF loads. The common mode voltage at the output pins is the same as the voltage at Pin 3.

BLOCK DIAGRAM

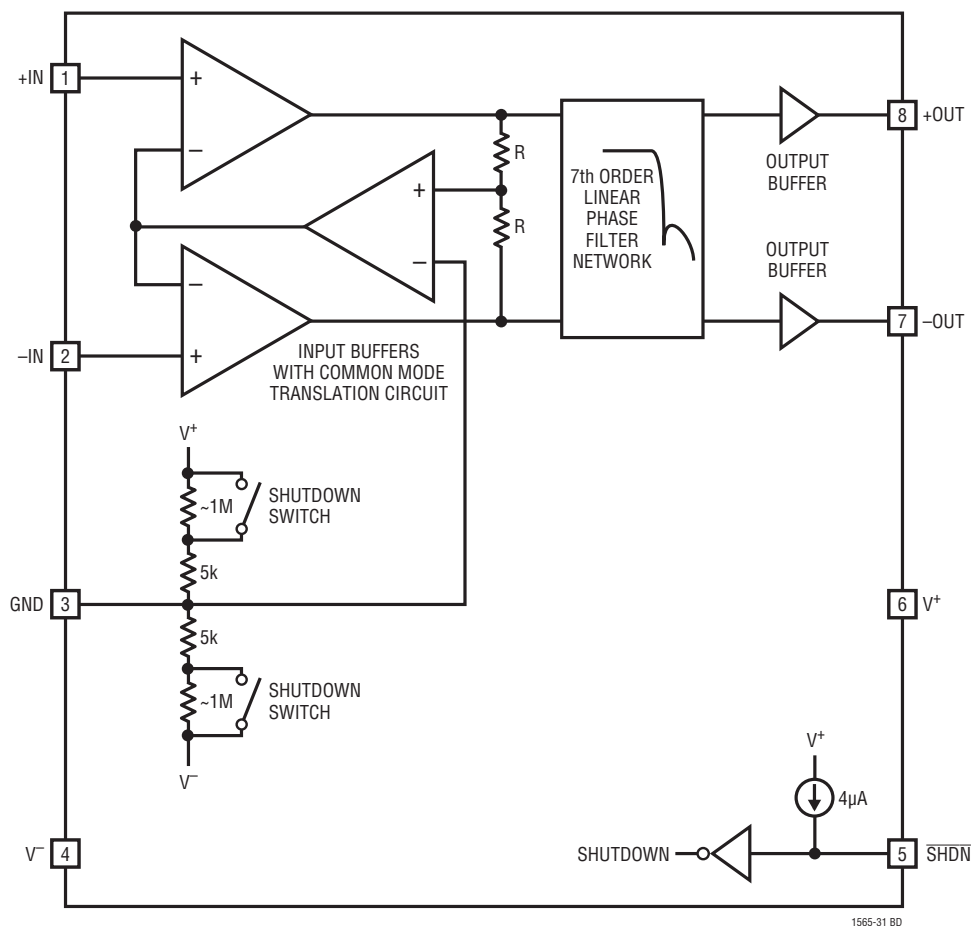

APPLICATIONS INFORMATION

Interfacing to the LTC1565-31

The difference between the voltages at Pin 1 and Pin 2 is the “differential input voltage.” The average of the voltages at Pin 1 and Pin 2 is the “common mode input voltage.” The difference between the voltages at Pin 7 and Pin 8 is the “differential output voltage.” The average of the voltages at Pin 7 and Pin 8 is the “common mode output voltage.” The input and output common mode voltages are independent. The input common mode voltage is set by the signal source, if DC coupled, or by the biasing network if AC coupled (Figures 1 and 2). The output common mode voltage is equal to the voltage of Pin 3, the GND pin. The GND pin is biased to one-half of the supply voltage by an internal resistive divider (see Block Diagram). To alter the common mode output voltage, Pin 3 can be driven with an external voltage source or resistor network. If external resistors are used, it is important to note that the internal 5k resistors can vary $\pm 20\%$ (their ratio only varies $\pm 1\%$). The output can also be AC coupled.

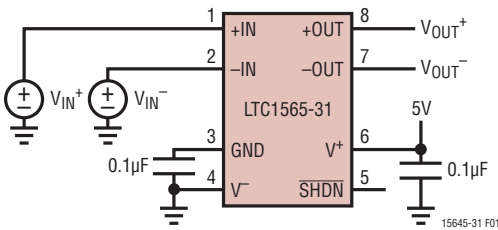

DC COUPLED INPUT

$$V_{IN} \text{ (COMMON MODE)} = \frac{V_{IN+} + V_{IN-}}{2}$$

$$V_{OUT} \text{ (COMMON MODE)} = \frac{V_{OUT+} + V_{OUT-}}{2} = \frac{V^+}{2}$$

Figure 1

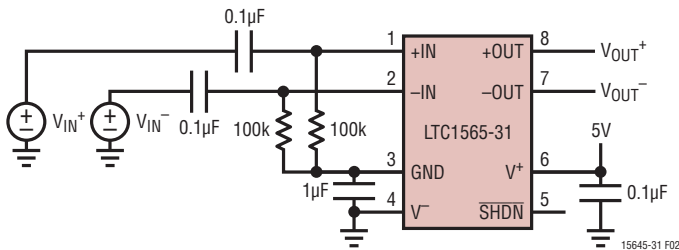

AC COUPLED INPUT

$$V_{IN} \text{ (COMMON MODE)} = V_{OUT} \text{ (COMMON MODE)}$$

$$= \frac{V^+}{2}$$

Figure 2

Input Common Mode and Differential Voltage Range

The range of voltage each input can support while operating in its linear region is typically 0.8V to 3.7V for a single 5V supply and $-4.2V$ to $3.2V$ for a $\pm 5V$ supply. Therefore, the filter can accept a variety of common mode input voltages. Figures 3 and 4 show the THD of the filter versus common mode input voltage with a $2V_{P-P}$ differential input signal.

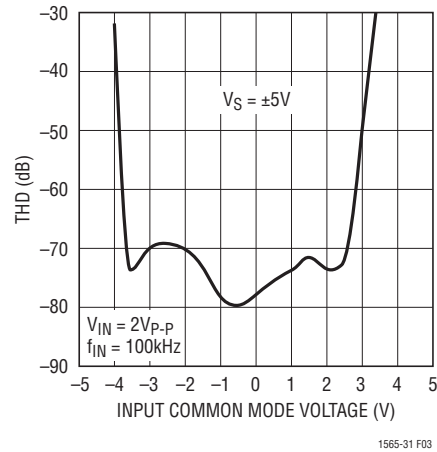

Figure 3. THD vs Common Mode Input Voltage

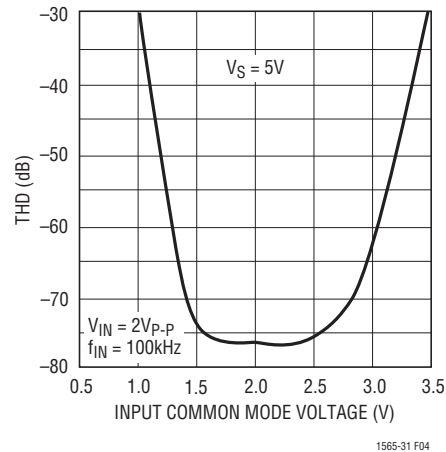

Figure 4. THD vs Common Mode Input Voltage

Figure 5 shows the THD and S/N ratio versus differential input voltage level for both a single 5V supply and a $\pm 5V$ supply. The common mode voltage of the input signal is one-half the total power supply voltage of the filter. The spurious free dynamic range, where the THD and S/N ratio are equal, is 75dB to 76dB when the differential input voltage level is $2V_{P-P}$; that is, for a single 5V supply, the

156531fa

APPLICATIONS INFORMATION

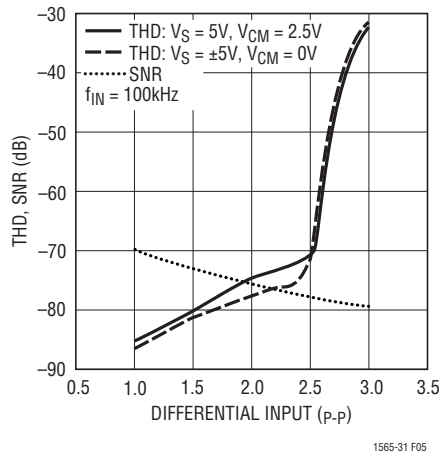

Figure 5. Dynamic Range Diff-In, Diff-Out

input voltages are Pin 1 = 2.5V DC \pm 0.5V and Pin 2 = 2.5V DC \pm 0.5V. Also note Figure 5 shows a 78dB SNR ratio for higher THD levels.

As seen in Figures 3 and 4, the spurious free dynamic range can be optimized by setting the input common mode voltage slightly below one-half of the power supply voltage, i.e., 2V for a single 5V supply and $-0.5V$ for a $\pm 5V$ supply. Figure 6 shows the THD and SNR ratio versus differential input voltage level for both a single 5V supply and a $\pm 5V$ supply when the common mode input voltage is 2V and $-0.5V$ respectively.

For best performance, the inputs should be driven differentially. For single-ended signals, connect the unused input to Pin 3 or a common mode reference.

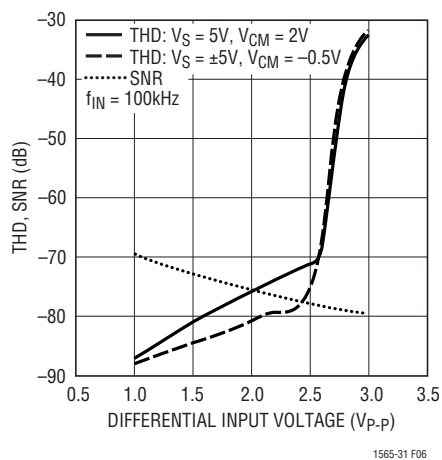

Figure 6. THD vs V_{IN} for a Common Mode Input Voltage 0.5V Below Mid Supply

Output Common Mode and Differential Voltage Range

The output is a fully differential signal with a common mode level equal to the voltage at Pin 3. The specifications in the Electrical Characteristics table assume the inputs are driven differentially and the output is observed differentially. However, Pin 8 can be used as a single-ended output by simply floating Pin 7. Pin 7 can be used as an inverting single-ended output by floating Pin 8. Using Pins 7 or 8 as single-ended outputs will decrease the performance.

The common mode output voltage can be adjusted by overdriving the voltage present on Pin 3. The best performance is achieved using a common mode output voltage that is equal to mid supply (the default Pin 3 voltage). Figures 7 and 8 illustrate the THD versus output common mode voltage for a 2V_{p-p} differential input voltage and a common mode input voltage that is 0.5V below mid supply.

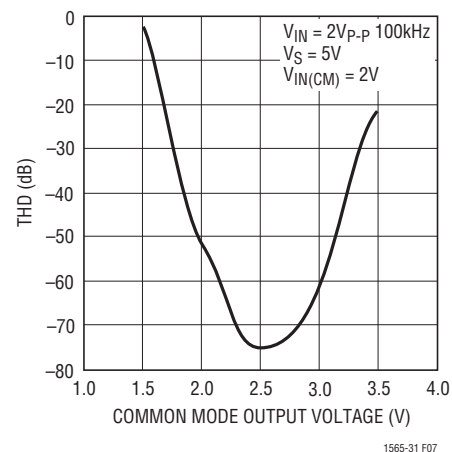

Figure 7. THD vs Common Mode Output Voltage

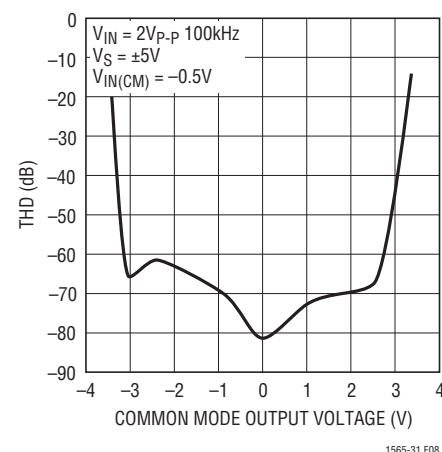

Figure 8. THD vs Common Mode Output Voltage

APPLICATIONS INFORMATION

Output Drive

Pin 7 and Pin 8 can drive a 1kΩ or 300pF load connected to AC ground with a ±0.5V signal (corresponding to a 2V_{P-P} differential signal). For differential loads (loads connected from Pin 7 to Pin 8) the outputs can produce a 2V_{P-P} differential signal across 2kΩ or 150pF. For smaller signal amplitudes the outputs can drive correspondingly larger loads.

Noise

The wideband noise of the filter is the RMS value of the device's output noise spectral density. The wideband noise data is used to determine the operating signal-to-noise at a given distortion level. Most of the noise is concentrated

in the filter passband and cannot be removed with post filtering (Table 1). Table 2 lists the typical change in wideband noise with supply voltage.

Table 1. Wideband Noise vs Bandwidth, Single 5V Supply

BANDWIDTH	TOTAL INTEGRATED NOISE
DC to f_{CUTOFF}	104μV _{RMS}
DC to $2 \cdot f_{CUTOFF}$	118μV _{RMS}

Table 2. Wideband Noise vs Supply Voltage, $f_{CUTOFF} = 650kHz$

POWER SUPPLY	TOTAL INTEGRATED NOISE DC TO $2 \cdot f_{CUTOFF}$
5V	118μV _{RMS}
±5V	120μV _{RMS}

TYPICAL APPLICATIONS

Test Circuit for Single 5V Supply Operation

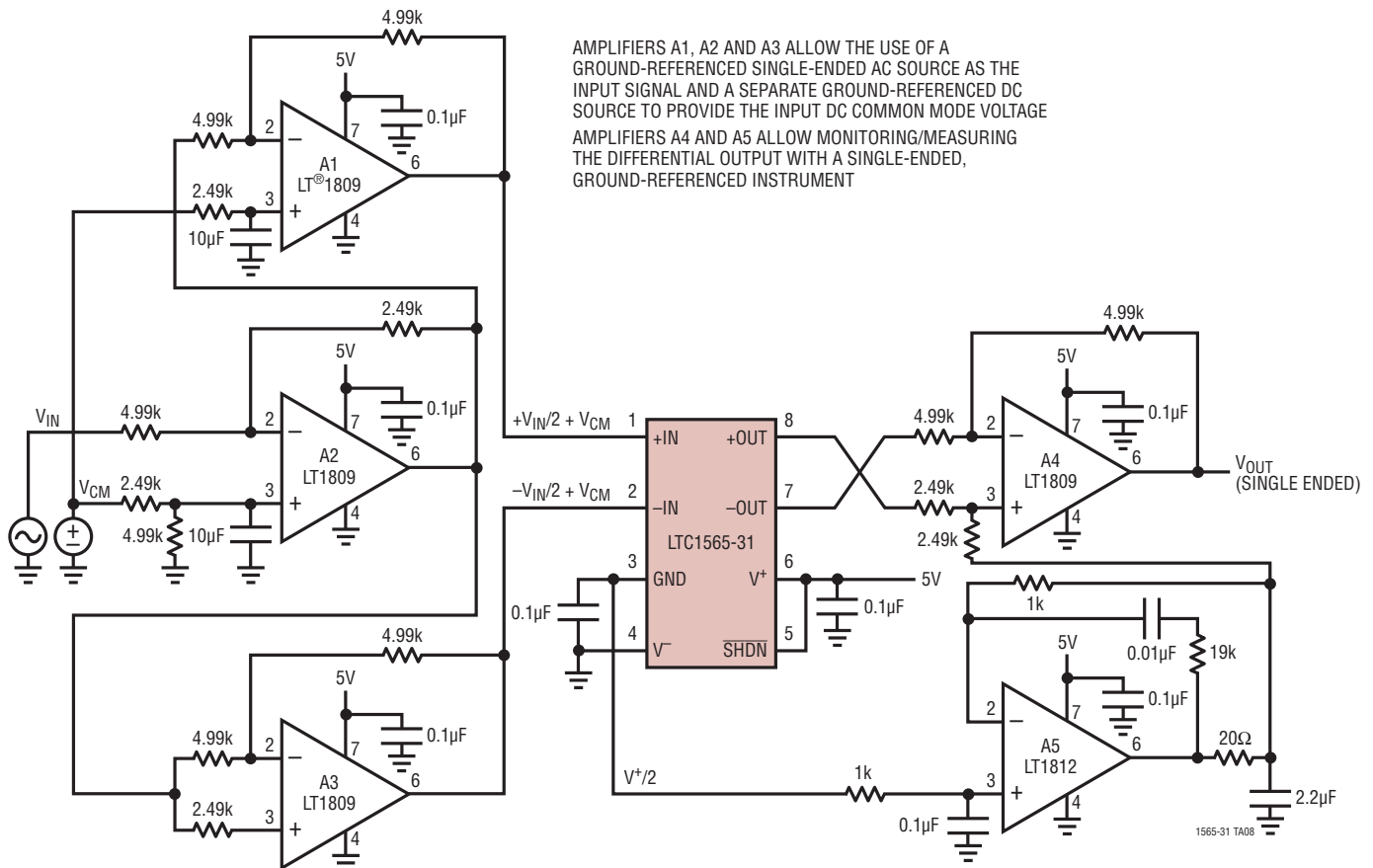

TYPICAL APPLICATIONS

Single-Ended Input/Output Dual Supply Filter

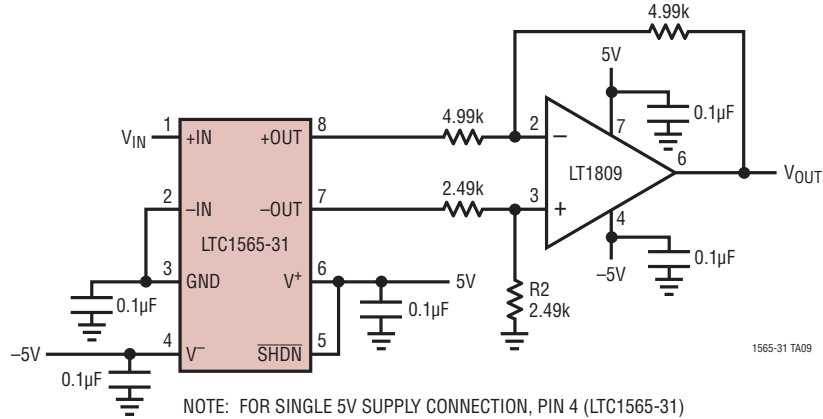

NOTE: FOR SINGLE 5V SUPPLY CONNECTION, PIN 4 (LTC1565-31) AND PIN 4 (LT1809) SHOULD BE GROUNDED AND RESISTOR R2 SHOULD BE DC BIASED AT APPROXIMATELY 2.5V (SEE TEST CIRCUIT FOR SINGLE SUPPLY OPERATION)

A Fully Differential Filter with Adjustable Output Common Mode Voltage

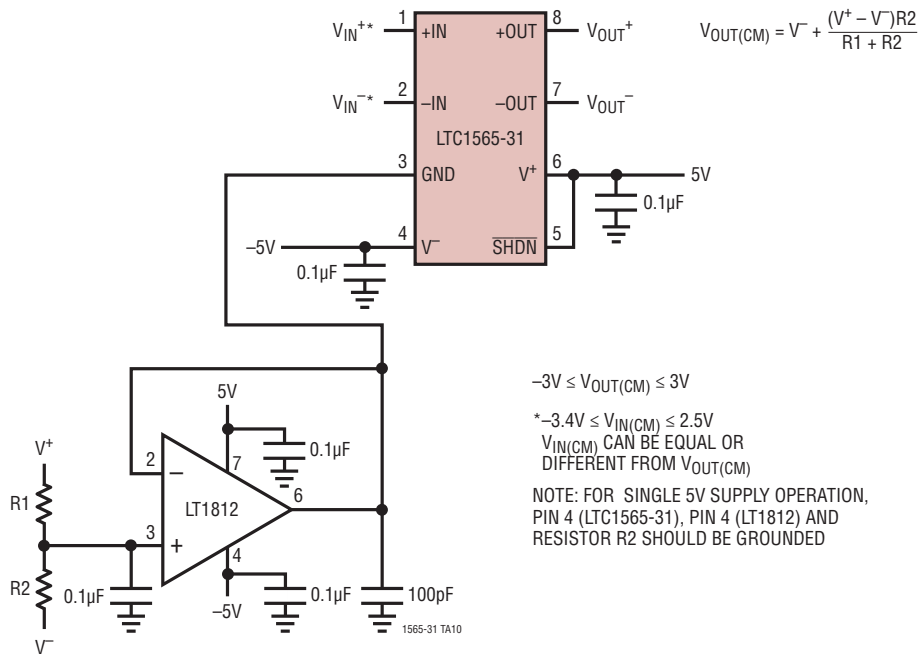

$$-3V \leq V_{OUT(CM)} \leq 3V$$

* $-3.4V \leq V_{IN(CM)} \leq 2.5V$
 $V_{IN(CM)}$ CAN BE EQUAL OR DIFFERENT FROM $V_{OUT(CM)}$

NOTE: FOR SINGLE 5V SUPPLY OPERATION, PIN 4 (LTC1565-31), PIN 4 (LT1812) AND RESISTOR R2 SHOULD BE GROUNDED

TYPICAL APPLICATIONS

Simple Pulse Shaping Circuit for Single 5V Operation, 1.25Mbps 2 Level Data

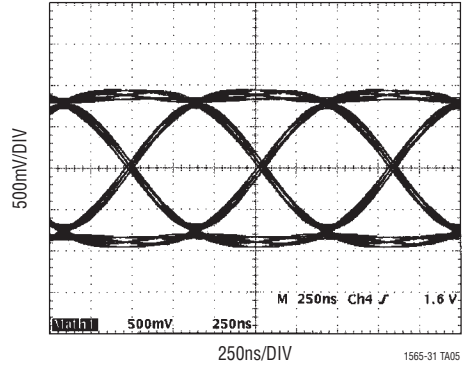
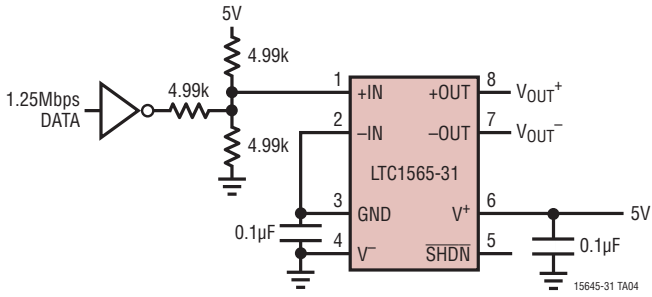

Simple Pulse Shaping Circuit for Single 5V Operation, 2Mbps (1Msps) 4 Level Data

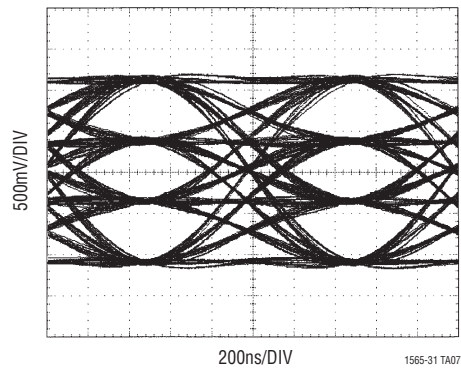
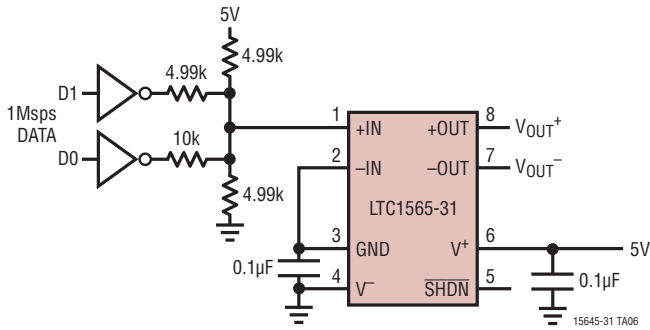

TYPICAL APPLICATIONS

Narrowband Cellular Basestation Receiver

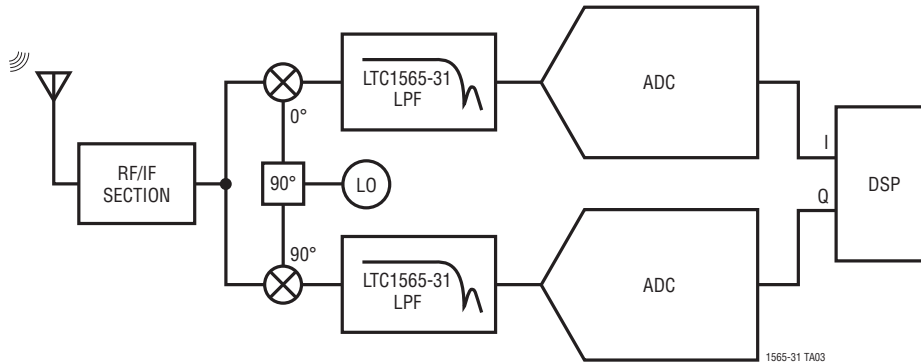

PACKAGE DESCRIPTION

S8 Package 8-Lead Plastic Small Outline (Narrow .150 Inch) (Reference LTC DWG # 05-08-1610)

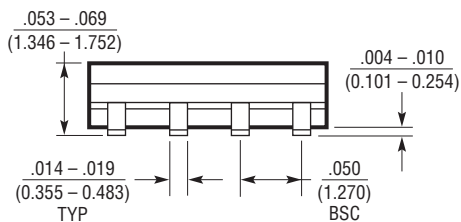
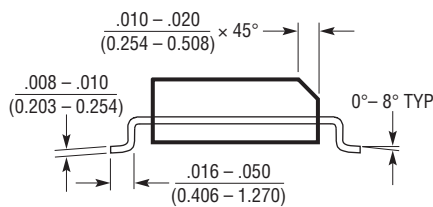
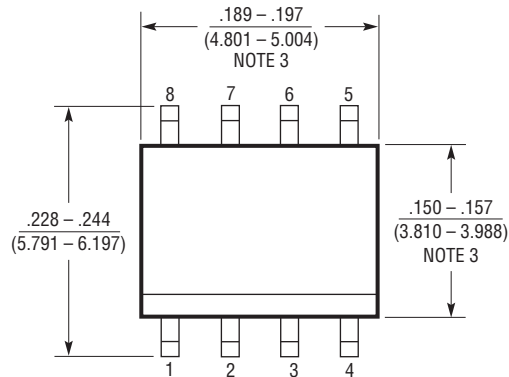
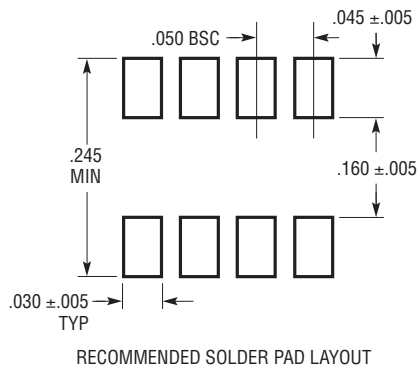

- NOTE:
 1. DIMENSIONS IN $\frac{\text{INCHES}}{\text{MILLIMETERS}}$
 2. DRAWING NOT TO SCALE
 3. THESE DIMENSIONS DO NOT INCLUDE MOLD FLASH OR PROTRUSIONS.
 MOLD FLASH OR PROTRUSIONS SHALL NOT EXCEED .006" (0.15mm)

S08 0303

TYPICAL APPLICATION

Selective 620kHz CDMA Filter

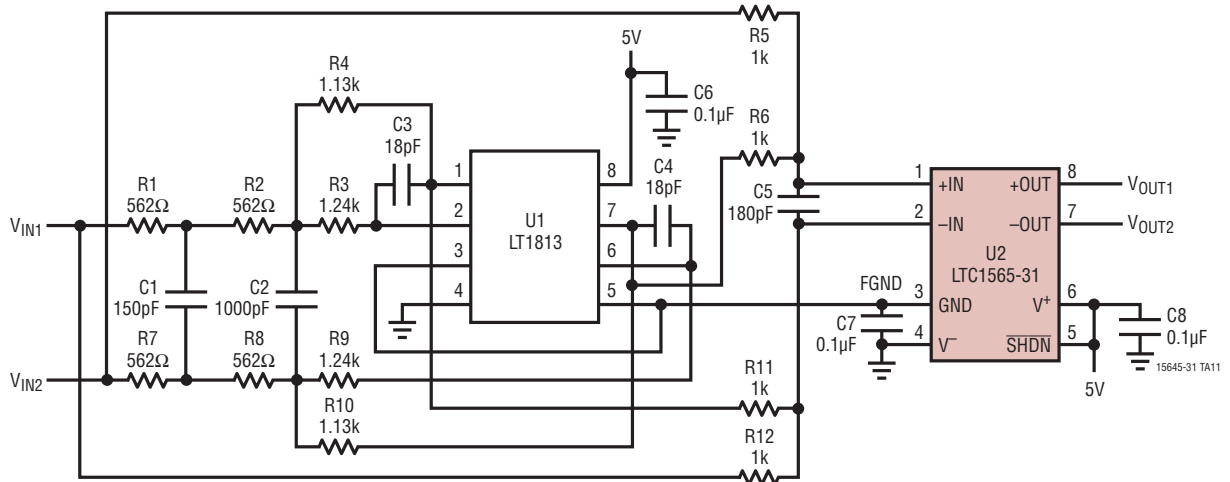

Frequency Response

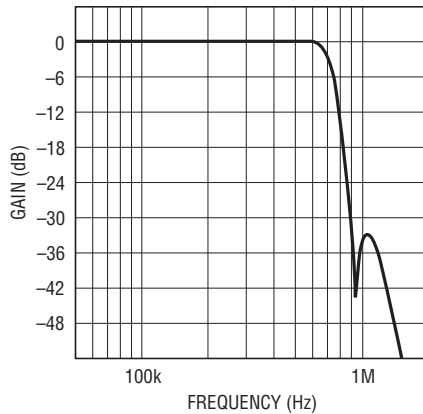

1565 TA12

RELATED PARTS

PART NUMBER	DESCRIPTION	COMMENTS
LTC1560-1	1MHz/500kHz Continuous Time, Low Noise, Lowpass Elliptic Filter	$f_{\text{CUTOFF}} = 500\text{kHz}$ or 1MHz
LTC1562/LTC1562-2	Universal 8th Order Active RC Filters	$f_{\text{CUTOFF(MAX)}} = 150\text{kHz}$ (LTC1562), $f_{\text{CUTOFF(MAX)}} = 300\text{kHz}$ (LTC1562-2)
LTC1563-2/LTC1563-3	4th Order Active RC Lowpass Filters	$f_{\text{CUTOFF(MAX)}} = 256\text{kHz}$
LTC1569-6/LTC1569-7	Self Clocked, 10th Order Linear Phase Lowpass Filters	$f_{\text{CLK}}/f_{\text{CUTOFF}} = 64/1$, $f_{\text{CUTOFF(MAX)}} = 75\text{kHz}$ (LTC1569-6) $f_{\text{CLK}}/f_{\text{CUTOFF}} = 32/1$, $f_{\text{CUTOFF(MAX)}} = 300\text{kHz}$ (LTC1569-7)

Looking for pricing, stock, or lifecycle information?

Click below to explore more details on WIN SOURCE:

- ⊖ [View LTC1565-31CS8#TRPBF on WIN SOURCE](#)
- ⊖ [Linear Technology Information](#)

Optimize Your Supply Chain with WIN SOURCE Solutions

- ✓ Global Sourcing Solution
- ✓ Obsolete Management
- ✓ Cost Control Management
- ✓ Shortage Management
- ✓ Alternative Solution
- ✓ Excess Inventory Management