



**THE DATASHEET OF  
LTC1562IG-2#TRPBF**



## FEATURES

- Continuous Time—No Clock
- Four 2nd Order Filter Sections, 20kHz to 300kHz Center Frequency
- Butterworth, Chebyshev, Elliptic or Equiripple Delay Response
- Lowpass, Bandpass, Highpass Responses
- 99dB Typical S/N,  $\pm 5V$  Supply ( $Q = 1$ )
- 93dB Typical S/N, Single 5V Supply ( $Q = 1$ )
- Rail-to-Rail Input and Output Voltages
- DC Accurate to 3mV (Typ)
- $\pm 0.5\%$  Typical Center Frequency Accuracy
- “Zero-Power” Shutdown Mode
- Single or Dual Supply, 5V to 10V Total
- Resistor-Programmable  $f_0$ ,  $Q$ , Gain

## APPLICATIONS

- High Resolution Systems (14 Bits to 18 Bits)
- Antialiasing/Reconstruction Filters
- Data Communications, Equalizers
- Dual or I-and-Q Channels (Two Matched 4th Order Filters in One Package)
- Linear Phase Filtering
- Replacing LC Filter Modules

## DESCRIPTION

The LTC<sup>®</sup>1562-2 is a low noise, low distortion continuous time filter with rail-to-rail inputs and outputs, optimized for a center frequency ( $f_0$ ) of 20kHz to 300kHz. Unlike most monolithic filters, no clock is needed. Four independent 2nd order filter blocks can be cascaded in any combination, such as one 8th order or two 4th order filters. Each block's response is programmed with three external resistors for center frequency,  $Q$  and gain, using simple design formulas. Each 2nd order block provides lowpass and bandpass outputs. Highpass response is available if an external capacitor replaces one of the resistors. Allpass, notch and elliptic responses can also be realized.

The LTC1562-2 is designed for applications where dynamic range is important. For example, by cascading 2nd order sections in pairs, the user can configure the IC as a dual 4th order Butterworth lowpass filter with 90dB signal-to-noise ratio from a single 5V power supply. Low level signals can exploit the built-in gain capability of the LTC1562-2. Varying the gain of a section can achieve a dynamic range as high as 114dB with a  $\pm 5V$  supply.

Other cutoff frequency ranges can be provided upon request. Please contact LTC Marketing.

 LTC and LT are registered trademarks of Linear Technology Corporation.

## TYPICAL APPLICATION

Dual 4th Order 200kHz Butterworth Lowpass Filter, SNR 96dB

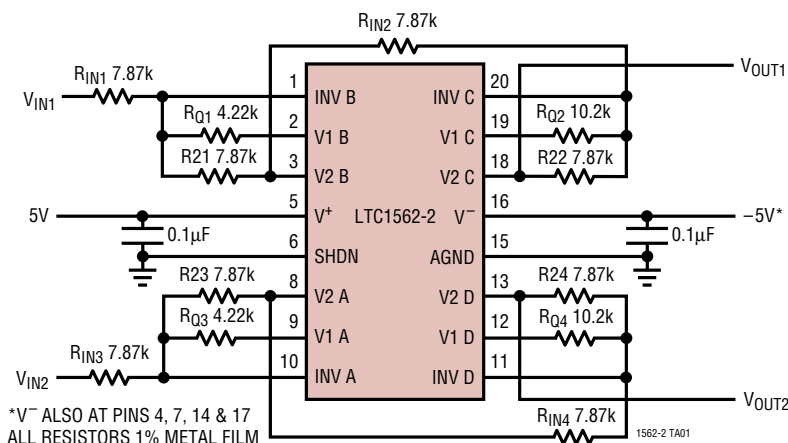

Amplitude Response

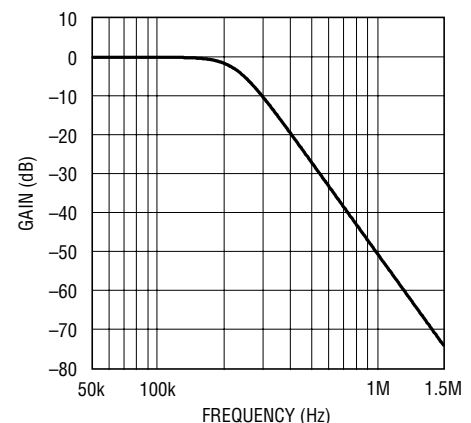

1562-2 TA02

15622fa

## ABSOLUTE MAXIMUM RATINGS

(Note 1)

Total Supply Voltage ( $V^+$ to $V^-$ ) .....	11V
Maximum Input Voltage at Any Pin .....	$(V^- - 0.3V) \leq V \leq (V^+ + 0.3V)$
Storage Temperature Range .....	$-65^\circ\text{C}$ to $150^\circ\text{C}$
Operating Temperature Range	
LTC1562C-2 .....	$0^\circ\text{C}$ to $70^\circ\text{C}$
LTC1562I-2 .....	$-40^\circ\text{C}$ to $85^\circ\text{C}$
Lead Temperature (Soldering, 10 sec) .....	$300^\circ\text{C}$

## PACKAGE/ORDER INFORMATION

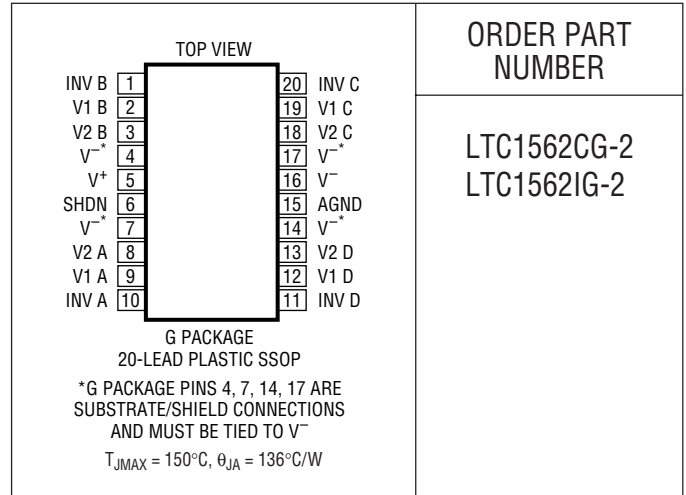

ORDER PART NUMBER

LTC1562CG-2  
LTC1562IG-2

Consult LTC Marketing for parts specified with wider operating temperature ranges.

## ELECTRICAL CHARACTERISTICS

The ● denotes specifications that apply over the full operating temperature range, otherwise specifications are at  $T_A = 25^\circ\text{C}$ .  $V_S = \pm 5\text{V}$ , outputs unloaded, SHDN pin to logic "low", unless otherwise noted. AC specs are for a single 2nd order section,  $R_{IN} = R_2 = 10.4\text{k}\Omega \pm 0.1\%$ ,  $R_Q = 9.09\text{k}\Omega \pm 0.1\%$ ,  $f_0 = 175\text{kHz}$ .

SYMBOL	PARAMETER	CONDITIONS	MIN	TYP	MAX	UNITS	
$V_S$	Total Supply Voltage		4.75		10.5	V	
$I_S$	Supply Current	$V_S = \pm 2.375\text{V}$ , $R_L = 5\text{k}$ , $C_L = 30\text{pF}$ , Outputs at 0V		21	23.5	mA	
		$V_S = \pm 5\text{V}$ , $R_L = 5\text{k}$ , $C_L = 30\text{pF}$ , Outputs at 0V		22.5	25	mA	
		$V_S = \pm 2.375\text{V}$ , $R_L = 5\text{k}$ , $C_L = 30\text{pF}$ , Outputs at 0V $V_S = \pm 5\text{V}$ , $R_L = 5\text{k}$ , $C_L = 30\text{pF}$ , Outputs at 0V	● ●		28 30	mA mA	
	Output Voltage Swing, V2 Outputs	$V_S = \pm 2.375\text{V}$ , $R_L = 5\text{k}$ , $C_L = 30\text{pF}$	●	4.2	4.6	$V_{P-P}$	
		$V_S = \pm 5\text{V}$ , $R_L = 5\text{k}$ , $C_L = 30\text{pF}$	●	9.3	9.8	$V_{P-P}$	
	Output Voltage Swing, V1 Outputs	$V_S = \pm 2.375\text{V}$ , $R_L = 5\text{k}$ , $C_L = 30\text{pF}$ , $f = 250\text{kHz}$		4.5		$V_{P-P}$	
		$V_S = \pm 5\text{V}$ , $R_L = 5\text{k}$ , $C_L = 30\text{pF}$ , $f = 250\text{kHz}$		8.4	9.7	$V_{P-P}$	
$V_{OS}$	DC Offset Magnitude, V2 Outputs	$V_S = \pm 2.375\text{V}$ , Input at AGND Voltage		3	17	mV	
		$V_S = \pm 5\text{V}$ , Input at AGND Voltage		3	17	mV	
	DC AGND Reference Point	$V_S = \text{Single } 5\text{V Supply}$		2.5		V	
	Center Frequency ( $f_0$ ) Error (Notes 2, 3)	$V_S = \pm 5\text{V}$ , V2 Output Has $R_L = 5\text{k}$ , $C_L = 30\text{pF}$		0.5	1.7	%	
$H_L$	Lowpass Passband Gain at V2 Output	$V_S = \pm 2.375\text{V}$ , $f_{IN} = 10\text{kHz}$ , V2 Output Has $R_L = 5\text{k}$ , $C_L = 30\text{pF}$	●	0	+0.05	+0.1	dB
	Q Accuracy	$V_S = \pm 2.375\text{V}$ , V2 Output Has $R_L = 5\text{k}$ , $C_L = 30\text{pF}$		+2		%	
	Wideband Output Noise	$V_S = \pm 2.375\text{V}$ , BW = 400kHz, Input AC GND		39		$\mu\text{V}_{RMS}$	
		$V_S = \pm 5\text{V}$ , BW = 400kHz, Input AC GND		39		$\mu\text{V}_{RMS}$	
	Input-Referred Noise, Gain = 100	BW = 400kHz, $f_0 = 200\text{kHz}$ , Q = 1, Input AC GND		7.3		$\mu\text{V}_{RMS}$	

**ELECTRICAL CHARACTERISTICS** The ● denotes specifications that apply over the full operating temperature range, otherwise specifications are at  $T_A = 25^\circ\text{C}$ .  $V_S = \pm 5\text{V}$ , outputs unloaded, SHDN pin to logic “low”, unless otherwise noted. AC specs are for a single 2nd order section,  $R_{IN} = R_2 = 10.4\text{k} \pm 0.1\%$ ,  $R_Q = 9.09\text{k} \pm 0.1\%$ ,  $f_0 = 175\text{kHz}$ .

SYMBOL	PARAMETER	CONDITIONS	MIN	TYP	MAX	UNITS
THD	Total Harmonic Distortion, V2 Output	$f_{IN} = 20\text{kHz}$ , $2.8\text{V}_{p-p}$ , V1 and V2 Outputs Have $R_L = 5\text{k}$ , $C_L = 30\text{pF}$		-100		dB
		$f_{IN} = 20\text{kHz}$ , $9\text{V}_{p-p}$ , V1 and V2 Outputs Have $R_L = 5\text{k}$ , $C_L = 30\text{pF}$		-82		dB
	Shutdown Supply Current	SHDN Pin to $V^+$ SHDN Pin to $V^+$ , $V_S = \pm 2.375\text{V}$		1.5 1.0	15	$\mu\text{A}$ $\mu\text{A}$
	Shutdown-Input Logic Threshold			2.5		V
	Shutdown-Input Bias Current	SHDN Pin to 0V		-10	-20	$\mu\text{A}$
	Shutdown Delay	SHDN Pin Steps from 0V to $V^+$		20		$\mu\text{s}$
	Shutdown Recovery Delay	SHDN Pin Steps from $V^+$ to 0V		100		$\mu\text{s}$
	Inverting Input Bias Current, Each Biquad			5		$\rho\text{A}$

**Note 1:** Absolute Maximum Ratings are those values beyond which the life of a device may be impaired.

**Note 3:** Tighter frequency tolerance is available, consult factory.

**Note 2:**  $f_0$  change from  $\pm 5\text{V}$  to  $\pm 2.375$  supplies is  $-0.2\%$  typical,  $f_0$  temperature coefficient magnitude,  $25^\circ\text{C}$  to  $85^\circ\text{C}$ , is  $50\text{ppm}/^\circ\text{C}$  typical.

As with the LTC1562,  $f_0$  decreases with increasing temperature.

**TYPICAL PERFORMANCE CHARACTERISTICS**

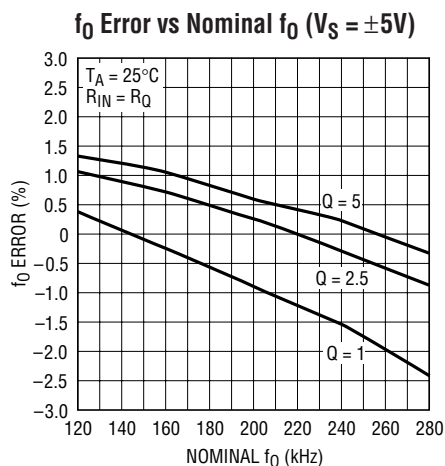

1562-2 G01

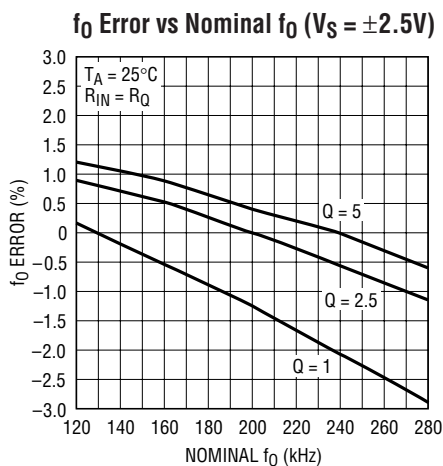

1562-2 G02

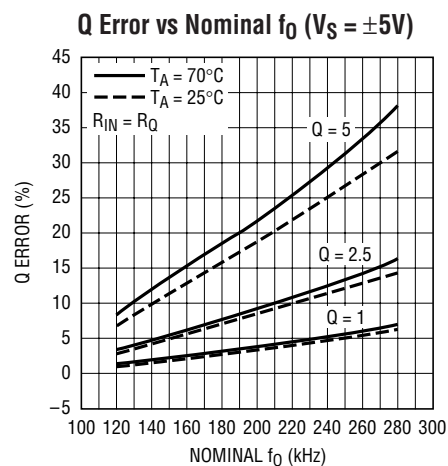

1562-2 G03

## TYPICAL PERFORMANCE CHARACTERISTICS

Q Error vs Nominal  $f_0$  ( $V_S = \pm 2.5V$ )

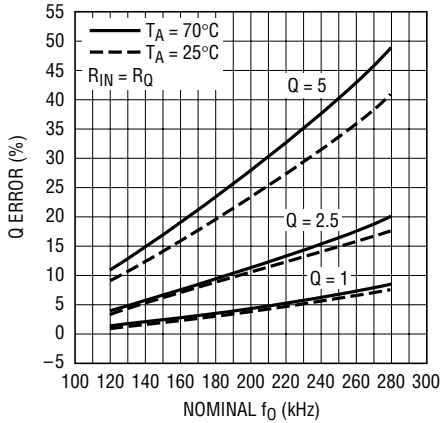

1562-2 G04

Peak BP Gain vs Nominal  $f_0$  ( $V_S = \pm 5V$ ) (Figure 3, V1 Output)

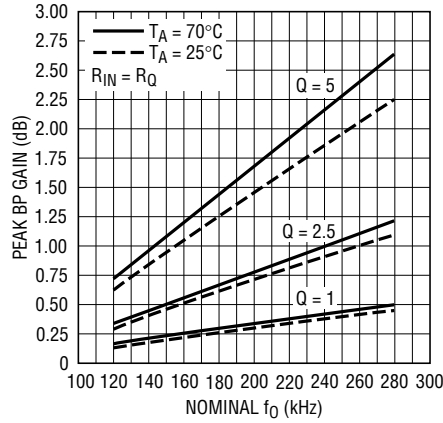

1562-2 G5

Peak BP Gain vs Nominal  $f_0$  ( $V_S = \pm 2.5V$ ) (Figure 3, V1 Output)

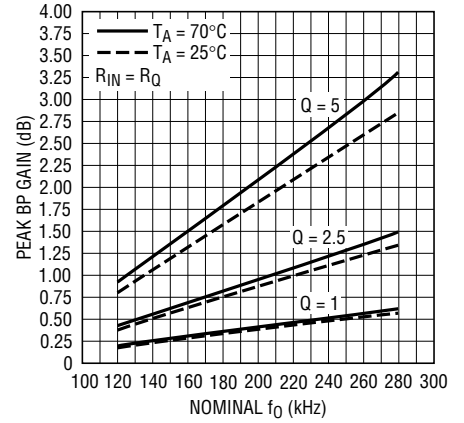

1562-2 G6

LP Noise vs Nominal  $f_0$  ( $V_S = \pm 5V$ , 25°C) (Figure 3, V2 Output) ( $R_{IN} = R_2$ )

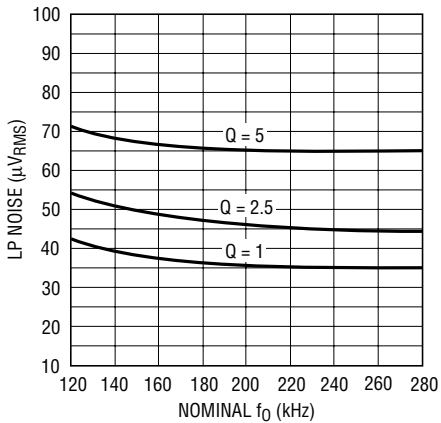

1562-2 G07

BP Noise vs Nominal  $f_0$  ( $V_S = \pm 5V$ , 25°C) (Figure 3, V1 Output) ( $R_{IN} = R_Q$ )

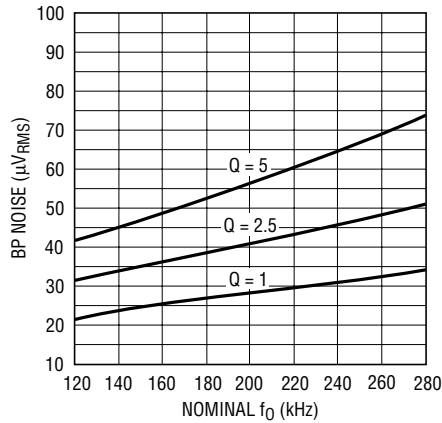

1562-2 G08

Distortion vs External Load Resistance and Frequency ( $V_S = \pm 5V$ , 25°C) (Figure 8)

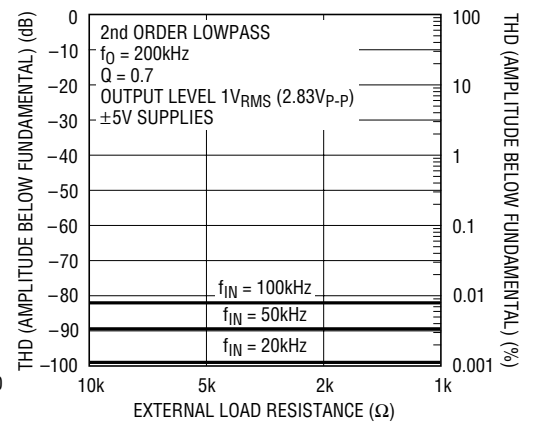

1562-2 G09

## PIN FUNCTIONS

**Power Supply Pins:** The  $V^+$  and  $V^-$  pins should be bypassed with 0.1µF capacitors to an adequate analog ground or ground plane. These capacitors should be connected as closely as possible to the supply pins. Pins 4, 7, 14 and 17 are internally connected to  $V^-$  (Pin 16) and should also be tied to the same point as Pin 16 for best shielding. Low noise linear supplies are recommended. Switching supplies are not recommended as they will lower the filter dynamic range.

**Analog Ground (AGND):** The AGND pin is the midpoint of a resistive voltage divider, developing a potential halfway between the  $V^+$  and  $V^-$  pins, with an equivalent series resistance nominally 7k. This serves as an internal ground reference. Filter performance will reflect the quality of the analog signal ground and an analog ground plane surrounding the package is recommended. The analog ground plane should be connected to any digital ground at a single point. For dual supply operation, the AGND pin

## PIN FUNCTIONS

should be connected to the ground plane (Figure 1). For single supply operation, the AGND pin should be bypassed to the ground plane with at least a 0.1  $\mu\text{F}$  capacitor (at least 1  $\mu\text{F}$  for best AC performance) (Figure 2).

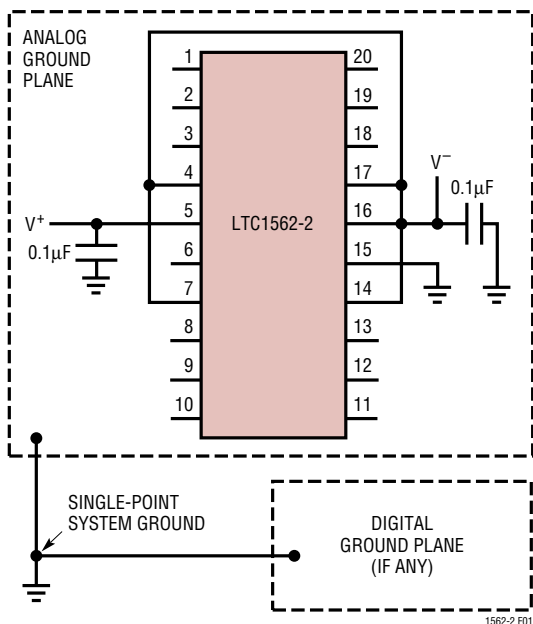

Figure 1. Dual Supply Ground Plane Connection (Including Substrate Pins 4, 7, 14, 17)

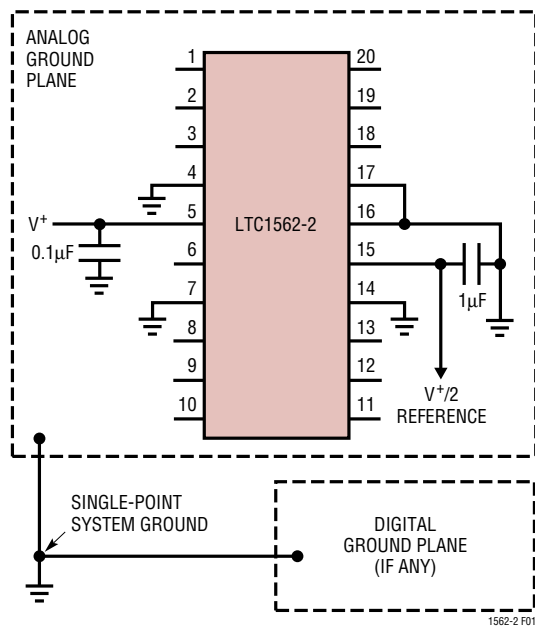

Figure 2. Single Supply Ground Plane Connection (Including Substrate Pins 4, 7, 14, 17)

**Shutdown (SHDN):** When the SHDN input goes high or is open-circuited, the LTC1562-2 enters a “zero-power” shutdown state and only junction leakage currents flow. The AGND pin and the amplifier outputs (see Figure 3) assume a high impedance state and the amplifiers effectively disappear from the circuit. (If an input signal is applied to a complete filter circuit while the LTC1562-2 is in shutdown, some signal will normally flow to the output through passive components around the inactive op amps.)

A small pull-up current source at the SHDN input *defaults the LTC1562-2 to the shutdown state if the SHDN pin is left floating*. Therefore, the user *must* connect the SHDN pin to a logic “low” (0V for  $\pm 5\text{V}$  supplies,  $V^-$  for 5V total supply) for normal operation of the LTC1562-2. (This convention permits true “zero-power” shutdown since not even the driving logic must deliver current while the part is in shutdown.) With a single supply voltage, use  $V^-$  for logic “low,” do not connect SHDN to the AGND pin.

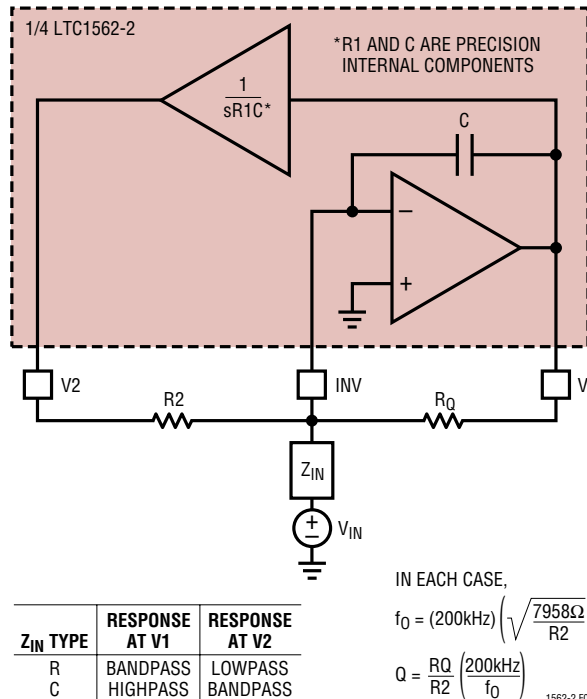

Figure 3. Equivalent Circuit of a Single 2nd Order Section (Inside Dashed Line) Shown in Typical Connection. Form of  $Z_{IN}$  Determines Response Types at the Two Outputs (See Table)

## PIN FUNCTIONS

**INV A, INV B, INV C, INV D:** Each of the INV pins is a virtual-ground summing point for the corresponding 2nd order section. For each section, all three external components  $Z_{IN}$ ,  $R_2$ ,  $R_Q$  connect to the INV pin as shown in Figure 3 and described further in the Applications Information. Note that the INV pins are sensitive internal nodes of the filter and will readily receive any unintended signals that are capacitively coupled into them. Capacitance to the INV nodes will also affect the frequency response of the filter sections. For these reasons, printed circuit connections to the INV pins must be kept as short as possible, less than one inch (2.5cm) total and surrounded by a ground plane.

**V1 A, V1 B, V1 C, V1 D:** Output Pins. Provide a bandpass, highpass or other response depending on external circuitry (see Applications Information section). Each V1 pin

also connects to the  $R_Q$  resistor of the corresponding 2nd order filter section (see Figure 3 and Applications Information). Each output is designed to drive a nominal net load of  $4k\Omega$  and  $30pF$ , which includes the loading due to the external  $R_Q$ . Distortion performance improves when the outputs are loaded as lightly as possible.

**V2 A, V2 B, V2 C, V2 D:** Output Pins. Provide a lowpass, bandpass or other response depending on external circuitry (see Applications Information section). Each V2 pin also connects to the  $R_2$  resistor of the corresponding 2nd order filter section (see Figure 3 and Applications Information). Each output is designed to drive a nominal net load of  $4k\Omega$  and  $30pF$ , which includes the loading due to the external  $R_2$ . Distortion performance improves when the outputs are loaded as lightly as possible.

## BLOCK DIAGRAM

Overall Block Diagram Showing Four 3-Terminal 2nd Order Sections

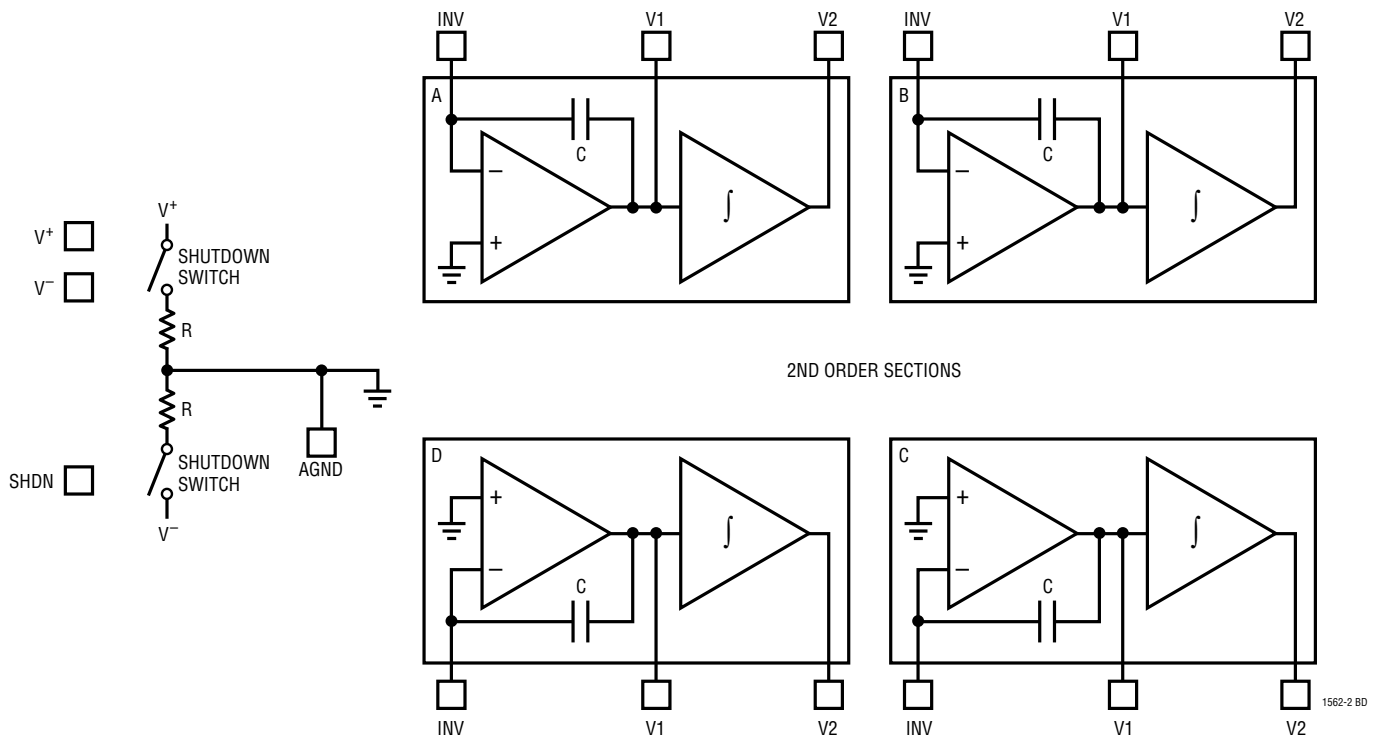

## APPLICATIONS INFORMATION

The LTC1562-2 contains four matched, 2nd order, 3-terminal universal continuous-time filter blocks, each with a virtual-ground input node (INV) and two rail-to-rail outputs (V1, V2). In the most basic application, one such block and three external resistors provide 2nd order lowpass and bandpass responses simultaneously (Figure 3, with a resistor for  $Z_{IN}$ ). The three external resistors program  $f_0$ , Q and gain. A combination of internal precision components and external resistor R2 sets the center frequency  $f_0$  of each 2nd order block. The LTC1562-2 is trimmed at manufacture so that  $f_0$  will be  $200\text{kHz} \pm 0.5\%$  if the external resistor R2 is exactly  $7958\Omega$ . The LTC1562-2 is a higher frequency, pin compatible variant of the LTC1562, with different internal R and C values and higher speed amplifiers.

However, lowpass/bandpass filtering is only one specific application for the 2nd order building blocks in the LTC1562-2. Highpass response results if the external impedance  $Z_{IN}$  in Figure 3 becomes a capacitor  $C_{IN}$  (whose value sets only gain, not critical frequencies) as described below. Responses with zeroes (e.g, elliptic or notch responses) are available by feedforward connections with multiple 2nd order blocks (see Typical Applications). Moreover, the virtual-ground input gives each 2nd order section the built-in capability for analog operations such as gain (preamplification), summing and weighting of multiple inputs, or accepting current or charge signals directly. **These Operational Filter™ frequency-selective building blocks are nearly as versatile as op amps.**

The user who is not copying exactly one of the Typical Applications schematics shown later in this data sheet is urged to read carefully the next few sections through at least Signal Swings, for orientation about the LTC1562-2, before attempting to design custom application circuits. Also available free from LTC, and recommended for designing custom filters, is the general-purpose analog filter design software FilterCAD™ for Windows®. This software includes tools for finding the necessary  $f_0$ , Q and gain parameters to meet target filter specifications such as frequency response.

### Setting $f_0$ and Q

Each of the four 2nd order sections in the LTC1562-2 can be programmed for a standard filter function (lowpass, bandpass or highpass) when configured as in Figure 3 with a resistor or capacitor for  $Z_{IN}$ . These transfer functions all have the same denominator, a complex pole pair with center frequency  $\omega_0 = 2\pi f_0$  and quality parameter Q. (The numerators depend on the response type as described below.) External resistors R2 and  $R_Q$  set  $f_0$  and Q as follows:

$$f_0 = \frac{1}{2\pi C\sqrt{(R1)R2}} = \left( \sqrt{\frac{7958\Omega}{R2}} \right) (200\text{kHz})$$

$$Q = \frac{R_Q}{\sqrt{(R1)R2}} = \frac{R_Q}{\sqrt{(7958\Omega)R2}} = \frac{R_Q}{R2} \left( \frac{200\text{kHz}}{f_0} \right)$$

$R1 = 7958\Omega$  and  $C = 100\text{pF}$  are internal to the LTC1562-2 while R2 and  $R_Q$  are external.

A typical design procedure proceeds from the desired  $f_0$  and Q as follows, using finite-tolerance fixed resistors. First find the ideal R2 value for the desired  $f_0$ :

$$R2(\text{Ideal}) = \left( \frac{200\text{kHz}}{f_0} \right)^2 (7958\Omega)$$

Then select a practical R2 value from the available finite-tolerance resistors. Use the actual R2 value to find the desired  $R_Q$ , which also will be approximated with finite tolerance:

$$R_Q = Q\sqrt{(7958\Omega)R2}$$

The  $f_0$  range is approximately 20kHz to 300kHz, limited mainly by the magnitudes of the external resistors required. As shown above, R2 varies with the inverse square of  $f_0$ . This relationship desensitizes  $f_0$  to R2's tolerance (by a factor of 2 incrementally), but it also implies that R2 has a wider range than  $f_0$ . ( $R_Q$  and  $R_{IN}$  also

Operational Filter and FilterCAD are trademarks of Linear Technology Corporation. Windows is a registered trademark of Microsoft Corporation.

## APPLICATIONS INFORMATION

tend to scale with R2.) At high  $f_0$  these resistors fall below 4k, heavily loading the outputs of the LTC1562-2 and leading to increased THD and other effects. At the other extreme, a lower  $f_0$  limit of 20kHz reflects an arbitrary upper resistor limit of 1MΩ. The LTC1562-2's MOS input circuitry can accommodate higher resistor values than this, but junction leakage current from the input protection circuitry may cause DC errors.

The 2nd order transfer functions  $H_{LP}(s)$ ,  $H_{BP}(s)$  and  $H_{HP}(s)$  (below) are all inverting so that, for example, at DC the lowpass gain is  $-H_L$ . If two such sections are cascaded, these phase inversions cancel. Thus, the filter in the application schematic on the first page of this data sheet is a dual DC preserving, noninverting, rail-to-rail lowpass filter, approximating two “straight wires with frequency selectivity.”

Figure 4 shows further details of 2nd order lowpass, bandpass and highpass responses. Configurations to obtain these responses appear in the next three sections.

### Basic Lowpass

When  $Z_{IN}$  of Figure 3 is a resistor of value  $R_{IN}$ , a standard 2nd order lowpass transfer function results from  $V_{IN}$  to  $V_2$  (Figure 5):

$$\frac{V_2(s)}{V_{IN}(s)} = H_{LP}(s) = \frac{-H_L \omega_0^2}{s^2 + (\omega_0 / Q)s + \omega_0^2}$$

$H_L = R_2/R_{IN}$  is the DC gain magnitude. (Note that the transfer function includes a sign inversion.) Parameters

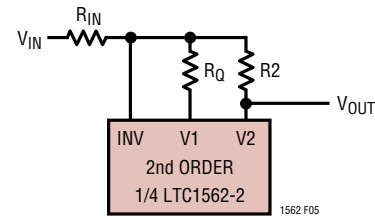

Figure 5. Basic Lowpass Configuration

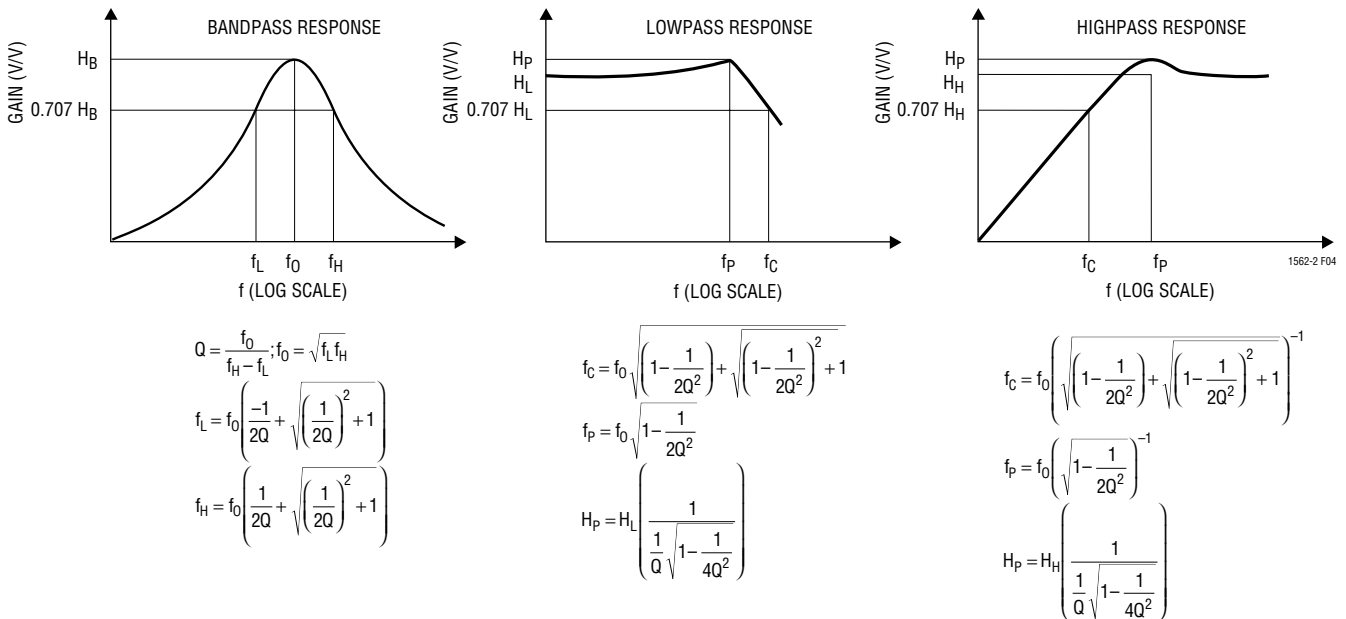

Figure 4. Characteristics of Standard 2nd Order Filter Responses

## APPLICATIONS INFORMATION

$\omega_0 (= 2\pi f_0)$  and  $Q$  are set by  $R_2$  and  $R_Q$  as above. For a 2nd order lowpass response the gain magnitude becomes  $QH_L$  at frequency  $f_0$ , and for  $Q > 0.707$ , a gain peak occurs at a frequency below  $f_0$ , as shown in Figure 4.

### Basic Bandpass

There are two different ways to obtain a bandpass function in Figure 3, both of which give the following transfer function form:

$$H_{BP}(s) = \frac{-H_B(\omega_0 / Q)s}{s^2 + (\omega_0 / Q)s + \omega_0^2}$$

The value of the gain parameter  $H_B$  depends on the circuit configuration as follows. When  $Z_{IN}$  is a resistor of value  $R_{IN}$ , a bandpass response results at the V1 output (Figure 6a) with a gain parameter  $H_B = R_Q/R_{IN}$ . Alternatively, a capacitor of value  $C_{IN}$  gives a bandpass response at the V2 output (Figure 6b), with the same  $H_{BP}(s)$  expression, and the gain parameter now  $H_B = (R_Q/7958\Omega)(C_{IN}/100\text{pF})$ . This transfer function has a gain magnitude of  $H_B$  (its peak value) when the frequency equals  $f_0$  and has a phase shift of  $180^\circ$  at that frequency.  $Q$  measures the sharpness of the peak (the ratio of  $f_0$  to  $-3\text{dB}$  bandwidth) in a 2nd order bandpass function, as illustrated in Figure 4.  $\omega_0 = 2\pi f_0$  and  $Q$  are set by  $R_2$  and  $R_Q$  as described previously in Setting  $f_0$  and  $Q$ .

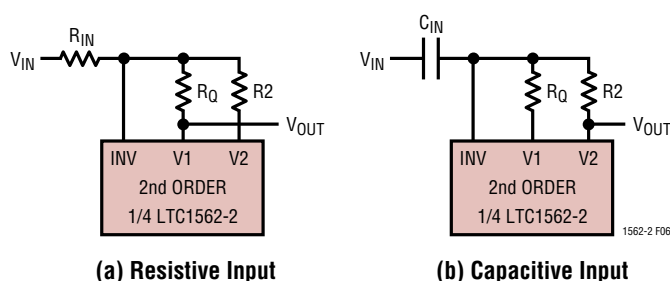

Figure 6. Basic Bandpass Configurations

### Basic Highpass

When  $Z_{IN}$  of Figure 3 is a capacitor of value  $C_{IN}$ , a highpass response appears at the V1 output (Figure 7).

$$\frac{V1(s)}{V_{IN}(s)} = H_{HP}(s) = \frac{-H_H s^2}{s^2 + (\omega_0 / Q)s + \omega_0^2}$$

$H_H = C_{IN}/100\text{pF}$  is the highpass gain parameter. Parameters  $\omega_0 = 2\pi f_0$  and  $Q$  are set by  $R_2$  and  $R_Q$  as above. For a 2nd order highpass response the gain magnitude at frequency  $f_0$  is  $QH_H$ , and approaches  $H_H$  at high frequencies ( $f \gg f_0$ ). For  $Q > 0.707$ , a gain peak occurs at a frequency above  $f_0$  as shown in Figure 4. The transfer function includes a sign inversion.

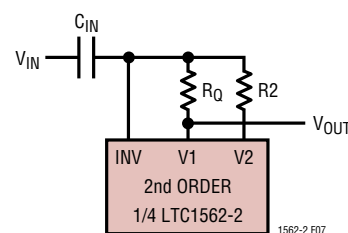

Figure 7. Basic Highpass Configuration

### Signal Swings

The V1 and V2 outputs are capable of swinging to within roughly 100mV of each power supply rail. As with any analog filter, the signal swings in each 2nd order section must be scaled so that no output overloads (saturates), even if it is not used as a signal output. (Filter literature often calls this the “dynamics” issue.) When an unused output has a larger swing than the output of interest, the section’s gain or input amplitude must be scaled down to avoid overdriving the unused output. The LTC1562-2 can still be used with high performance in such situations as long as this constraint is followed.

For an LTC1562-2 section as in Figure 3, the magnitudes of the two outputs V2 and V1, at a frequency  $\omega = 2\pi f$ , have the ratio,

$$\frac{|V2(j\omega)|}{|V1(j\omega)|} = \frac{(200\text{kHz})}{f}$$

regardless of the details of  $Z_{IN}$ . Therefore, an input frequency above or below 200kHz produces larger output amplitude at V1 or V2, respectively. This relationship can guide the choice of filter design for maximum dynamic range in situations (such as bandpass responses) where there is more than one way to achieve the desired frequency response with an LTC1562-2 section.

## APPLICATIONS INFORMATION

Because 2nd order sections with  $Q \geq 1$  have response peaks near  $f_0$ , the gain ratio above implies some rules of thumb:

- $f_0 < 200\text{kHz} \Rightarrow V2$  tends to have the larger swing
- $f_0 > 200\text{kHz} \Rightarrow V1$  tends to have the larger swing.

The following situations are convenient because the relative swing issue does not arise. The unused output's swing is naturally the smaller of the two in these cases:

- Lowpass response (resistor input, V2 output, Figure 5) with  $f_0 < 200\text{kHz}$
- Bandpass response (capacitor input, V2 output, Figure 6b) with  $f_0 < 200\text{kHz}$
- Bandpass response (resistor input, V1 output, Figure 6a) with  $f_0 > 200\text{kHz}$
- Highpass response (capacitor input, V1 output, Figure 7) with  $f_0 > 200\text{kHz}$

The LTC1562, a lower frequency variant of the LTC1562-2, has a design center  $f_0$  of 100kHz compared to 200kHz in the LTC1562-2. The rules summarized above apply to the LTC1562 but with 100kHz replacing the 200kHz limits. Thus, an LTC1562 highpass filter section with  $f_0$  above 100kHz automatically satisfies the desirable condition of the unused output carrying the smaller signal swing.

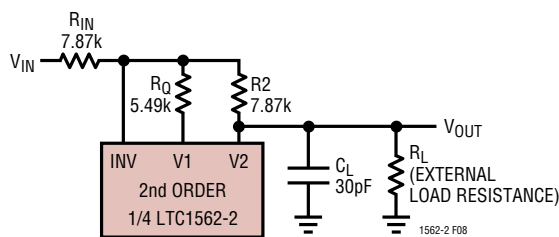

Figure 8. 200kHz,  $Q = 0.7$  Lowpass Circuit for Distortion vs Loading Test

### Low Level or Wide Range Input Signals

The LTC1562-2 contains a built-in capability for low noise amplification of low level signals. The  $Z_{IN}$  impedance in each 2nd order section controls the block's gain. When set for unity passband gain, a 2nd order section can deliver an output signal 99dB above the noise level. If low level inputs

require further dynamic range, reducing the value of  $Z_{IN}$  boosts the signal gain while reducing the input referred noise. This feature can increase the SNR for low level signals. Varying or switching  $Z_{IN}$  is also an efficient way to effect automatic gain control (AGC). From a system viewpoint, this technique boosts the ratio of maximum signal to minimum noise, for a typical 2nd order lowpass response ( $Q = 1$ ,  $f_0 = 200\text{kHz}$ ), to 114dB.

### Input Voltages Beyond the Power Supplies

Properly used, the LTC1562-2 can accommodate input voltage excursions well beyond its supply voltage. This requires care in design but can be useful, for example, when large out-of-band interference is to be removed from a smaller desired signal. The flexibility for different input voltages arises because the INV inputs are at virtual ground potential, like the inverting input of an op amp with negative feedback. The LTC1562-2 fundamentally responds to input *current* and the external voltage  $V_{IN}$  appears only across the external impedance  $Z_{IN}$  in Figure 3.

To accept beyond-the-supply input voltages, it is important to keep the LTC1562-2 powered on, not in shutdown mode, and to avoid saturating the V1 or V2 output of the 2nd order section that receives the input. If any of these conditions is violated, the INV input will depart from a virtual ground, leading to an overload condition whose recovery timing depends on circuit details. In the event that this overload drives the INV input beyond the supply voltages, the LTC1562-2 could be damaged.

The most subtle part of preventing overload is to consider the possible input signals or spectra and take care that none of them can drive either V1 or V2 to the supply limits. Note that neither output can be allowed to saturate, even if it is not used as the signal output. If necessary the passband gain can be reduced (by increasing the impedance of  $Z_{IN}$  in Figure 3) to reduce output swings.

The final issue to be addressed with beyond-the-supply inputs is current and voltage limits. Current entering the virtual ground INV input flows eventually through the output circuitry that drives V1 and V2. The input current magnitude ( $|V_{IN}| / |Z_{IN}|$  in Figure 3) should be limited by design to less than 1mA for good distortion performance. On the other hand, the input voltage  $V_{IN}$  appears across the

## APPLICATIONS INFORMATION

external component  $Z_{IN}$ , usually a resistor or capacitor. This component must of course be rated to sustain the magnitude of voltage imposed on it.

### Lowpass “T” Input Circuit

The virtual ground INV input in the Operational Filter block provides a means for adding an “extra” lowpass pole to any resistor-input application (such as the basic lowpass, Figure 5, or bandpass, Figure 6a). The resistor that would otherwise form  $Z_{IN}$  is split into two parts and a capacitor to ground added, forming an R-C-R “T” network (Figure 9). This adds an extra, independent real pole at a frequency:

$$f_P = \frac{1}{2\pi R_P C_T}$$

where  $C_T$  is the new external capacitor and  $R_P$  is the parallel combination of the two input resistors  $R_{INA}$  and  $R_{INB}$ . This pair of resistors must normally have a prescribed series total value  $R_{IN}$  to set the filter’s gain as described above. The parallel value  $R_P$  can however be set arbitrarily (to  $R_{IN}/4$  or less) which allows choosing a convenient standard capacitor value for  $C_T$  and fine tuning the new pole with  $R_P$ .

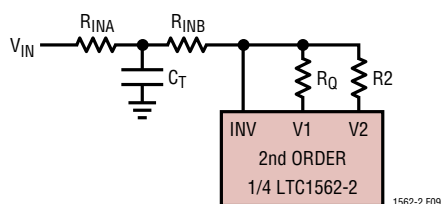

Figure 9. Lowpass “T” Input Circuit

The procedure therefore is to begin with the target extra pole frequency  $f_P$ . Determine the series value  $R_{IN}$  from the gain requirement. Select a capacitor value  $C_T$  such that  $R_P = 1/(2\pi f_P C_T)$  is no greater than  $R_{IN}/4$ , and then choose  $R_{INA}$  and  $R_{INB}$  that will simultaneously have the parallel value  $R_P$  and the series value  $R_{IN}$ . Such  $R_{INA}$  and  $R_{INB}$  can be found directly from the expression:

$$\frac{1}{2}R_{IN} \pm \frac{1}{2}\sqrt{R_{IN}^2 - (4R_{IN}R_P)}$$

A practical limitation of this technique is that the  $C_T$  capacitor values that tend to be required (hundreds or thousands of pF) can destabilize the op amp in Figure 3 if  $R_{INB}$  is too small, leading to AC errors such as Q enhancement. For this reason, when  $R_{INA}$  and  $R_{INB}$  are unequal, preferably the larger of the two should be placed in the  $R_{INB}$  position.

### Highpass “T” Input Circuit

A method similar to the preceding technique adds an “extra” highpass pole to any capacitor-input application (such as the bandpass of Figure 6b or the highpass of Figure 7). This method splits the input capacitance  $C_{IN}$  into two series parts  $C_{INA}$  and  $C_{INB}$ , with a resistor  $R_T$  to ground between them (Figure 10). This adds an extra 1st order highpass corner with a zero at DC and a pole at the frequency:

$$f_P = \frac{1}{2\pi R_T C_P}$$

where  $C_P = C_{INA} + C_{INB}$  is the parallel combination of the two capacitors. At the same time, the total series capacitance  $C_{IN}$  will control the filter’s gain parameter ( $H_H$  in Basic Highpass). For a given series value  $C_{IN}$ , the parallel value  $C_P$  can still be set arbitrarily (to  $4C_{IN}$  or greater).

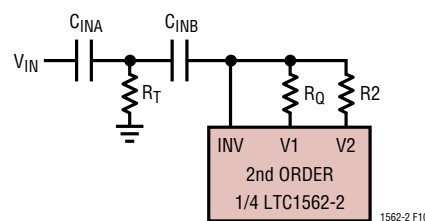

Figure 10. Highpass “T” Input Circuit

The procedure then is to begin with the target corner (pole) frequency  $f_P$ . Determine the series value  $C_{IN}$  from the gain requirement (for example,  $C_{IN} = H_H(100\text{pF})$  for a highpass). Select a resistor value  $R_T$  such that  $C_P = 1/(2\pi R_T f_P)$  is at least  $4C_{IN}$ , and select  $C_{INA}$  and  $C_{INB}$  that will simultaneously have the parallel value  $C_P$  and the series value  $C_{IN}$ . Such  $C_{INA}$  and  $C_{INB}$  can be found directly from the expression:

$$\frac{1}{2}C_P \pm \frac{1}{2}\sqrt{C_P^2 - (4C_{IN}C_P)}$$

# LTC1562-2

This procedure can be iterated, adjusting the value of  $R_T$ , to find convenient values for  $C_{INA}$  and  $C_{INB}$  since resistor values are generally available in finer increments than capacitor values.

resistors and capacitors are provided to build application-specific filters. Also provided are terminals for inputs, outputs and power supplies.

## LTC1562/LTC1562-2 Demo Board

The LTC demonstration board DC266 is assembled with an LTC1562 or LTC1562-2 in a 20-pin SSOP package and power supply decoupling capacitors. Jumpers on the board configure the filter chip for dual or single supply operation and power shutdown. Pads for surface mount

## Notches and Elliptic Responses

Further circuit techniques appear in the LTC1562 data sheet under the heading “Notches and Elliptic Responses.” These techniques are directly applicable to the LTC1562-2 with the substitution of the different values for the internal components R1 and C. In the LTC1562-2, R1 is  $7958\Omega$  and C is  $100\text{pF}$ .

# TYPICAL APPLICATIONS

175kHz 8th Order Elliptic Highpass Filter

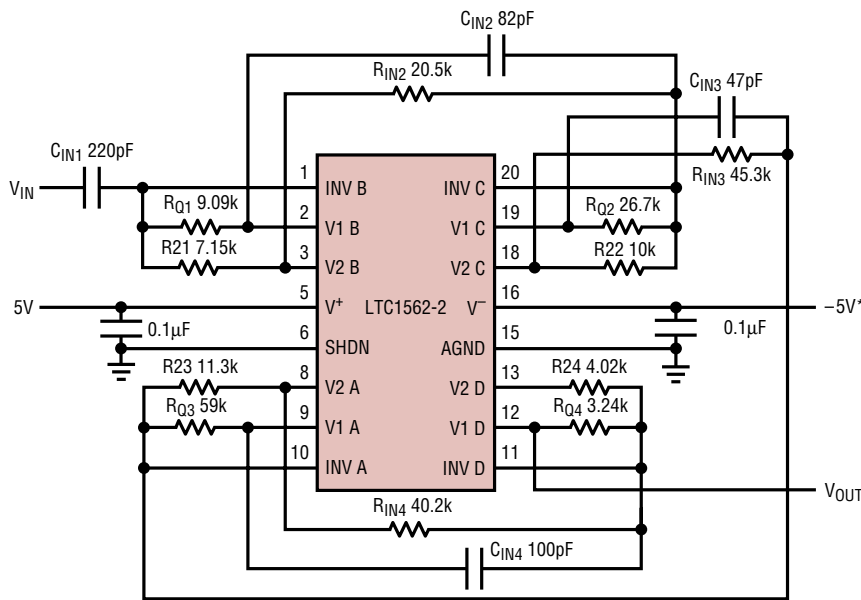

\* $V^-$  ALSO AT PINS 4, 7, 14 & 17  
 ALL RESISTORS 1% METAL FILM  
 ALL CAPACITORS 5% STANDARD VALUES

1562-2 TA03a

Amplitude Response

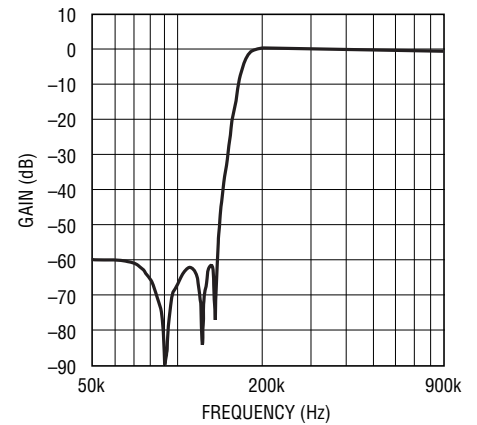

1562-2 TA03b

# TYPICAL APPLICATIONS

Dual 5th Order 170kHz Elliptic Highpass Filter, Single 5V Supply

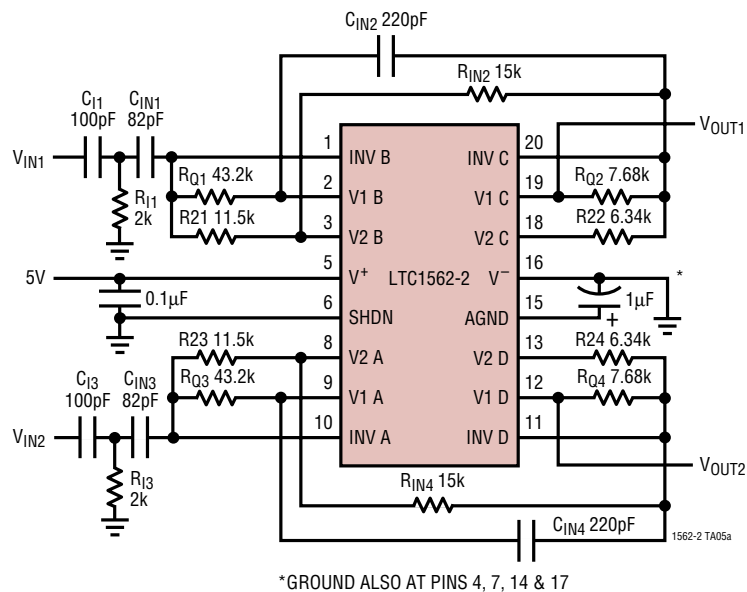

Amplitude Response

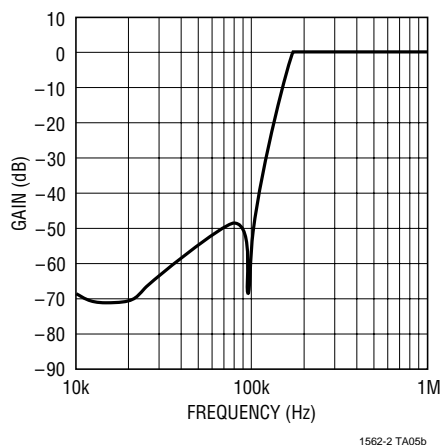



# TYPICAL APPLICATIONS

## LTC1562-2 9th Order 200kHz Lowpass Elliptic Filter

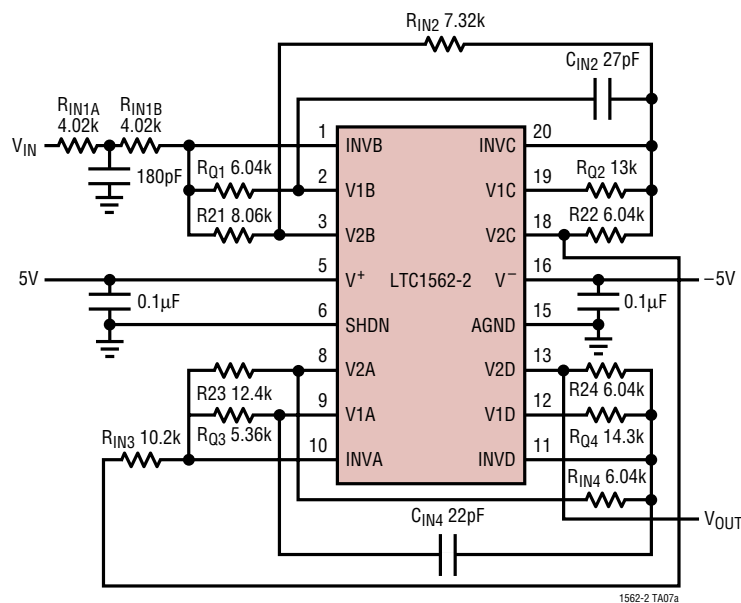

PINS 4, 7, 14, 17 (NOT SHOWN) ALSO CONNECT TO V<sup>-</sup>  
ALL RESISTORS ARE ±1%, ALL CAPACITORS ARE ±5%

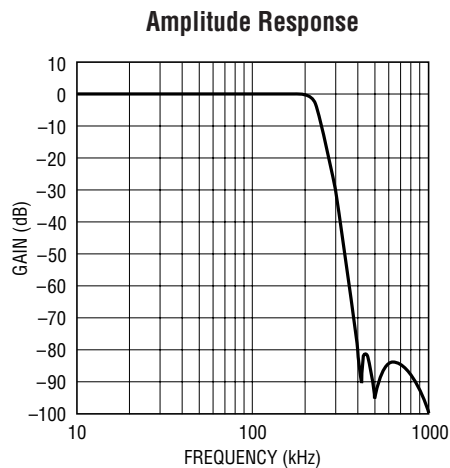

# PACKAGE DESCRIPTION

## G Package 20-Lead Plastic SSOP (5.3mm) (Reference LTC DWG # 05-08-1640)

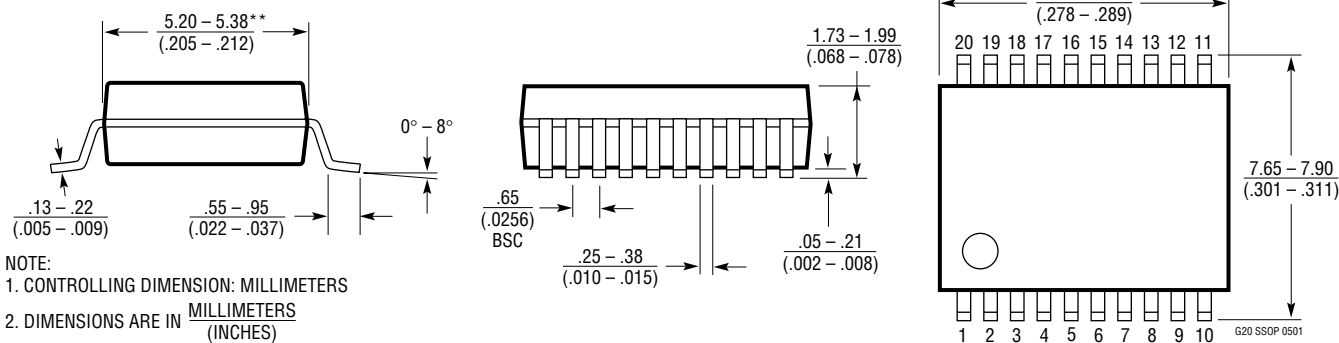

- NOTE:
1. CONTROLLING DIMENSION: MILLIMETERS
  2. DIMENSIONS ARE IN MILLIMETERS (INCHES)
  3. DRAWING NOT TO SCALE
- \*DIMENSIONS DO NOT INCLUDE MOLD FLASH. MOLD FLASH SHALL NOT EXCEED .152mm (.006") PER SIDE
- \*\*DIMENSIONS DO NOT INCLUDE INTERLEAD FLASH. INTERLEAD FLASH SHALL NOT EXCEED .254mm (.010") PER SIDE

**TYPICAL APPLICATION**

**256kHz Linear Phase 6th Order Lowpass Filter with a 2nd Order Allpass Phase Equalizer, Single Supply**

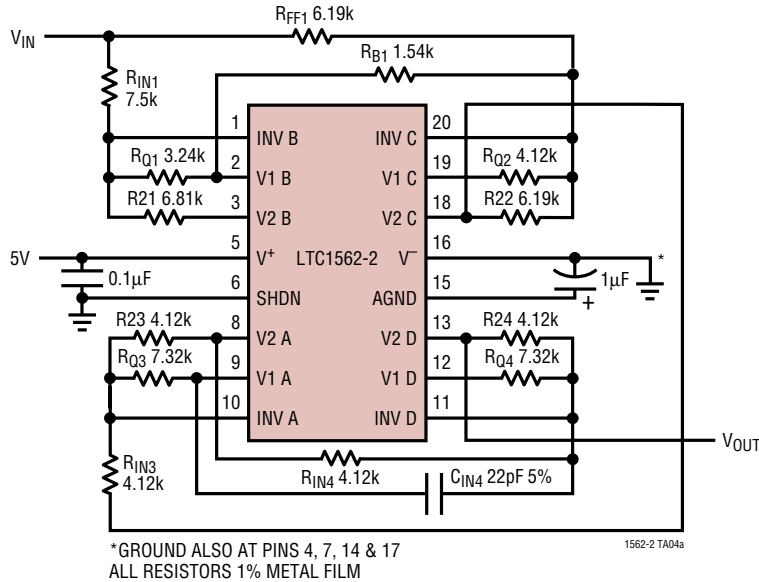

**Amplitude Response**

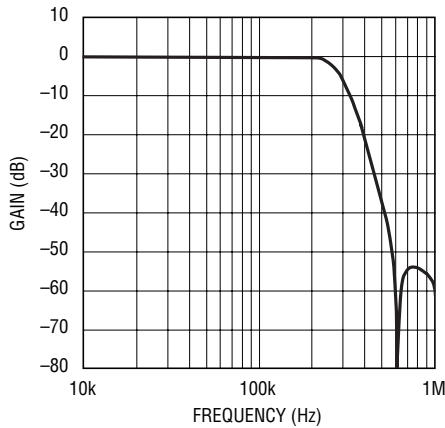

**Group Delay Response**

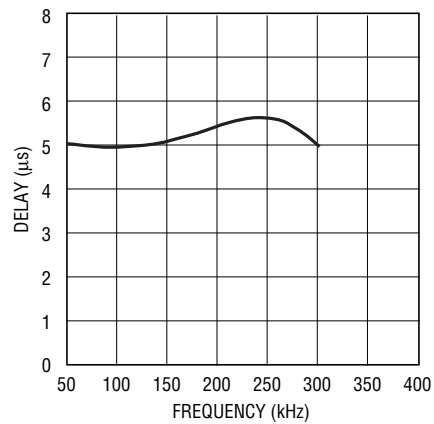

**RELATED PARTS**

PART NUMBER	DESCRIPTION	COMMENTS
LTC1068-X	Quad 2-Pole Switched Capacitor Building Block	Clock Tuned
LTC1560-1	5-Pole Elliptic Lowpass, $f_C = 1\text{MHz}/0.5\text{MHz}$	No External Components, S08
LTC1562	Quad 2-Pole Active RC, 10kHz to 150kHz	Same Pinout as LTC1562-2
LTC1563-2/LTC1563-3	4th Order Active RC Lowpass Filters	$f_{\text{CUTOFF(MAX)}} = 256\text{kHz}$ , Resistor Programmable
LTC1564	10kHz to 150kHz Digitally Controlled Filter and PGA	Continuous Time Low Noise 8th Order with PGA
LTC1565-31	650kHz Continuous Time, Linear Phase Lowpass Filter	7th Order, Differential Inputs and Outputs
LTC1566-1	2.3MHz Continuous Time Lowpass Filter	7th Order, Differential Inputs and Outputs

15622fa

## Looking for pricing, stock, or lifecycle information?

Click below to explore more details on WIN SOURCE:

 [View LTC1562IG-2#TRPBF on WIN SOURCE](#)

 [Linear Technology](#) Information

## Optimize Your Supply Chain with WIN SOURCE Solutions

-  Global Sourcing Solution
-  Obsolete Management
-  Cost Control Management
-  Shortage Management
-  Alternative Solution
-  Excess Inventory Management