



**THE DATASHEET OF
LTC1458LIG#PBF**



LTC1458/LTC1458L

ABSOLUTE MAXIMUM RATINGS

(Note 1)

V_{CC} to GND	-0.5V to 7.5V
Logic Inputs to GND	-0.5V to 7.5V
$V_{OUT A}$, $V_{OUT B}$, $V_{OUT C}$, $V_{OUT D}$, X1/X2 A, X1/X2 B, X1/X2 C, X1/X2 D	-0.5V to $V_{CC} + 0.5V$
REFHI A, REFHI B, REFHI C, REFHI D, REFLO A, REFLO B, REFLO C, REFLO D	-0.5V to $V_{CC} + 0.5V$
Maximum Junction Temperature	125°C
Operating Temperature Range	
LTC1458C/LTC1458LC	0°C to 70°C
LTC1458I/LTC1458LI	-40°C to 85°C
Storage Temperature Range	-65°C to 150°C
Lead Temperature (Soldering, 10 sec)	300°C

PACKAGE/ORDER INFORMATION

TOP VIEW		ORDER PART NUMBER
X1/X2 C	1	LTC1458CG LTC1458CSW LTC1458LCG LTC1458LCSW LTC1458IG LTC1458ISW LTC1458LIG LTC1458LISW
$V_{OUT C}$	2	
$\overline{CS/LD}$	3	
D _{IN}	4	
REFHI C	5	
GND	6	
REFLO C	7	
REFLO D	8	
REFHI D	9	
D _{OUT}	10	
CLK	11	
NC	12	
$V_{OUT D}$	13	
X1/X2 D	14	
	15	V_{CC}
	16	X1/X2 A
	17	$V_{OUT A}$
	18	NC
	19	REFOUT
	20	REFHI A
	21	REFLO A
	22	REFLO B
	23	GND
	24	REFHI B
	25	CLR
	26	$V_{OUT B}$
	27	X1/X2 B
	28	V_{CC}

G PACKAGE 28-LEAD PLASTIC SSOP SW PACKAGE 28-LEAD PLASTIC SO

$T_{JMAX} = 125^{\circ}C$, $\theta_{JA} = 100^{\circ}C/W$ (G)
 $T_{JMAX} = 125^{\circ}C$, $\theta_{JA} = 150^{\circ}C/W$ (SW)

Consult factory for Military grade parts.

ELECTRICAL CHARACTERISTICS

The ● denotes the specifications which apply over the full operating temperature range, otherwise specifications are at $T_A = T_{MIN}$ to T_{MAX} . $V_{CC} = 4.5V$ to $5.5V$ (LTC1458), $2.7V$ to $5.5V$ (LTC1458L), X1/X2 = REFLO = GND, REFHI = REFOUT, V_{OUT} unloaded, unless otherwise noted.

SYMBOL	PARAMETER	CONDITIONS	MIN	TYP	MAX	UNITS	
DAC							
	Resolution		●	12		Bits	
DNL	Differential Nonlinearity	Guaranteed Monotonic (Note 2)	●		±0.5	LSB	
INL	Integral Nonlinearity	$T_A = 25^{\circ}C$ (Note 2)	●	±1.75 ±2.25	±4.0 ±4.5	LSB LSB	
V_{OS}	Offset Error	$T_A = 25^{\circ}C$	●	±3.0 ±6.0	±12 ±18	mV mV	
V_{OSTC}	Offset Error Temperature Coefficient			±15		$\mu V/^{\circ}C$	
V_{FS}	Full-Scale Voltage	When Using Internal Reference, LTC1458, $T_A = 25^{\circ}C$	●	4.065 4.045	4.095 4.095	4.125 4.145	V V
		When Using Internal Reference, LTC1458L, $T_A = 25^{\circ}C$	●	2.470 2.460	2.500 2.500	2.530 2.540	V V
$V_{FS TC}$	Full-Scale Voltage Temperature Coefficient	When Using Internal Reference		±24		ppm/ $^{\circ}C$	
Reference							
	Reference Output Voltage	LTC1458	●	2.008	2.048	2.088	V
		LTC1458L	●	1.195	1.220	1.245	V
	Reference Output Temperature Coefficient			±20		ppm/ $^{\circ}C$	
	Reference Line Regulation		●	0.7	±2.0	LSB/V	
	Reference Load Regulation	$0 \leq I_{OUT} \leq 100\mu A$, LTC1458 LTC1458L	●	0.2	1.5	LSB	
			●	0.6	3.0	LSB	
	Reference Input Range	$V_{REFHI} \leq V_{CC} - 1.5V$		$V_{CC}/2$		V	
	Reference Input Resistance		●	15	24	40	k Ω

ELECTRICAL CHARACTERISTICS The ● denotes the specifications which apply over the full operating temperature range, otherwise specifications are at $T_A = T_{MIN}$ to T_{MAX} . $V_{CC} = 4.5V$ to $5.5V$ (LTC1458), $2.7V$ to $5.5V$ (LTC1458L), $X1/X2 = REFLO = GND$, $REFHI = REFOUT$, V_{OUT} unloaded, unless otherwise noted.

SYMBOL	PARAMETER	CONDITIONS		MIN	TYP	MAX	UNITS
	Reference Input Capacitance				15		pF
	Short-Circuit Current	REFOUT Shorted to GND	●		45	120	mA

Power Supply

V_{CC}	Positive Supply Voltage	For Specified Performance, LTC1458 LTC1458L	● ●	4.5 2.7		5.5 5.5	V V
I_{CC}	Supply Current	$4.5V \leq V_{CC} \leq 5.5V$ (Note 5), LTC1458 $2.7V \leq V_{CC} \leq 5.5V$ (Note 5), LTC1458L	● ●		1100 800	2400 2000	μA μA

Op Amp DC Performance

	Short-Circuit Current Low	V_{OUT} Shorted to GND	●		60	120	mA
	Short-Circuit Current High	V_{OUT} Shorted to V_{CC}	●		70	120	mA
	Output Impedance to GND	Input Code = 0	●		40	160	Ω

AC Performance

	Voltage Output Slew Rate	(Note 3)	●	0.5	1.0		V/ μs
	Voltage Output Settling Time	(Notes 3, 4) to $\pm 0.5LSB$			14		μs
	Digital Feedthrough				0.3		nV•s
	AC Feedthrough	REFHI = 1kHz, 2V _{p-p} , (Code: All 0s)			-95		dB
SINAD	Signal-to-Noise + Distortion	REFHI = 1kHz, 2V _{p-p} , (Code: All 1s)			85		dB

The ● denotes the specifications which apply over the full operating temperature range, otherwise specifications are at $T_A = T_{MIN}$ to T_{MAX} . $V_{CC} = 5V$ (LTC1458), $3V$ (LTC1458L), unless otherwise noted.

SYMBOL	PARAMETER	CONDITIONS	LTC1458			LTC1458L			UNITS
			MIN	TYP	MAX	MIN	TYP	MAX	
Digital I/O									
V_{IH}	Digital Input High Voltage		●	2.4			2.0		V
V_{IL}	Digital Input Low Voltage		●			0.8		0.6	V
V_{OH}	Digital Output High Voltage	$I_{OUT} = -1mA$	●	$V_{CC} - 1.0$			$V_{CC} - 0.7$		V
V_{OL}	Digital Output Low Voltage	$I_{OUT} = 1mA$	●			0.4		0.4	V
I_{LEAK}	Digital Input Leakage	$V_{IN} = GND$ to V_{CC}	●			± 10		± 10	μA
C_{IN}	Digital Input Capacitance	Guaranteed by Design, Not Subject to Test	●			10		10	pF

Switching

t_1	D_{IN} Valid to CLK Setup		●	40			60		ns
t_2	D_{IN} Valid to CLK Hold		●	0			0		ns
t_3	CLK High Time		●	40			60		ns
t_4	CLK Low Time		●	40			60		ns
t_5	\overline{CS}/LD Pulse Width		●	50			80		ns
t_6	LSB CLK to \overline{CS}/LD		●	40			60		ns
t_7	\overline{CS}/LD Low to CLK		●	20			30		ns
t_8	D_{OUT} Output Delay	$C_{LOAD} = 15pF$	●			150		220	ns
t_9	CLK Low to \overline{CS}/LD Low		●	20			30		ns

ELECTRICAL CHARACTERISTICS

Note 1: Absolute Maximum Ratings are those values beyond which the life of a device may be impaired.

Note 2: Nonlinearity is defined from the first code that is greater than or equal to the maximum offset specification to code 4095 (full scale).

Note 3: Load is 5k Ω in parallel with 100pF.

Note 4: DAC switched between all 1s and the code corresponding to V_{OS} for the part.

Note 5: Digital inputs at 0V or V_{CC} .

TYPICAL PERFORMANCE CHARACTERISTICS

LTC1458
Differential Nonlinearity (DNL)

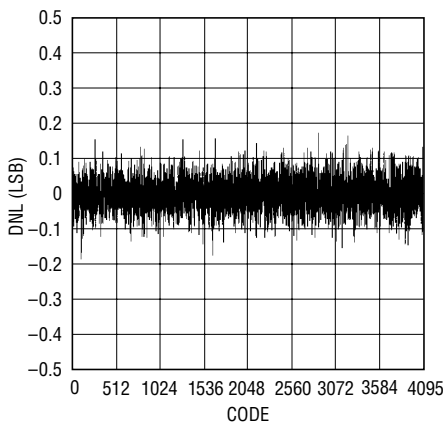

1458 G09

LTC1458
Integral Nonlinearity (INL)

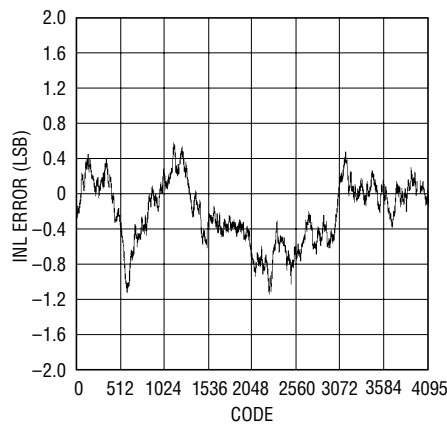

1458 G08

Minimum Supply Headroom for Full Output Swing vs Load Current

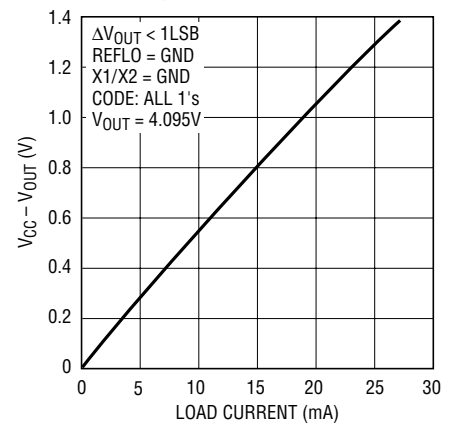

1458 G03

Minimum Output Voltage vs Output Sink Current

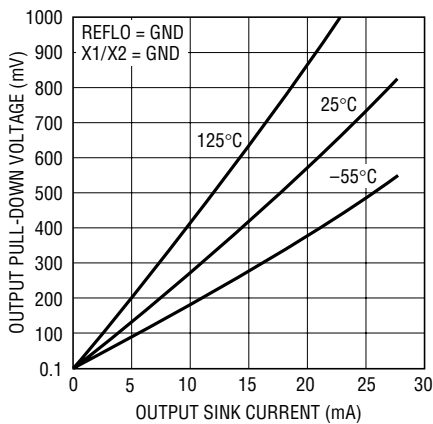

1458 G04

Output Swing vs Load Resistance

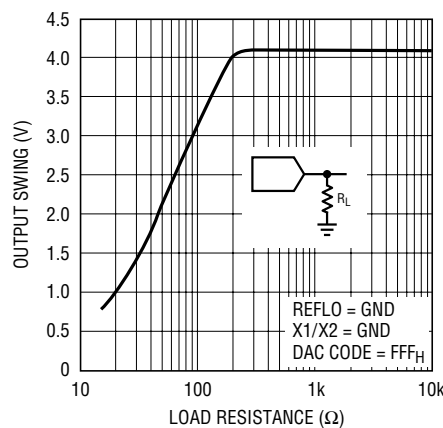

1458 G05A

Output Swing vs Load Resistance

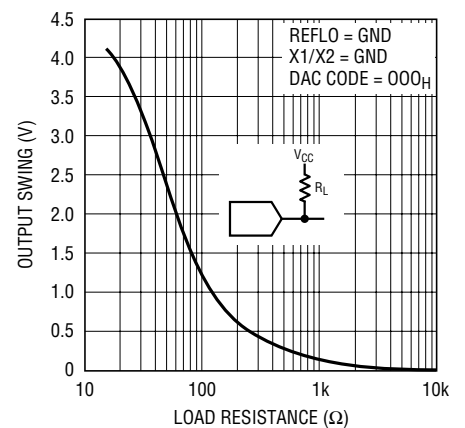

1458 G06A

TYPICAL PERFORMANCE CHARACTERISTICS

LTC1458 Full-Scale Voltage vs Temperature

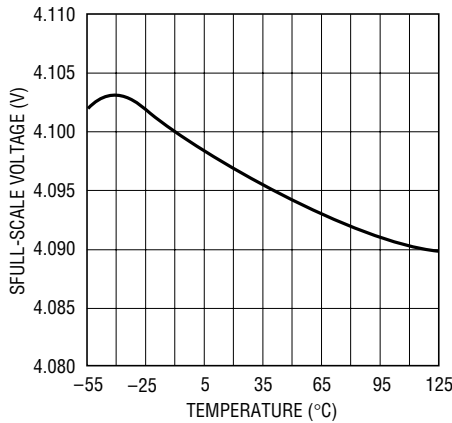

1458 G06

LTC1458 Offset Voltage vs Temperature

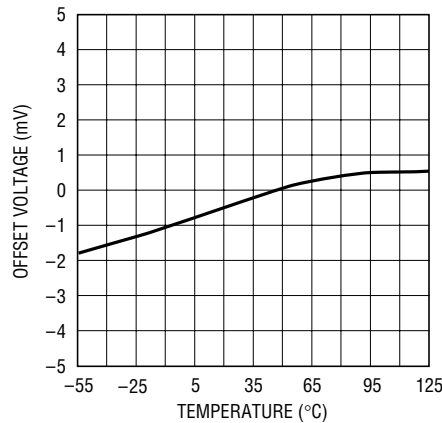

1458 G07

LTC1458 Supply Current vs Temperature

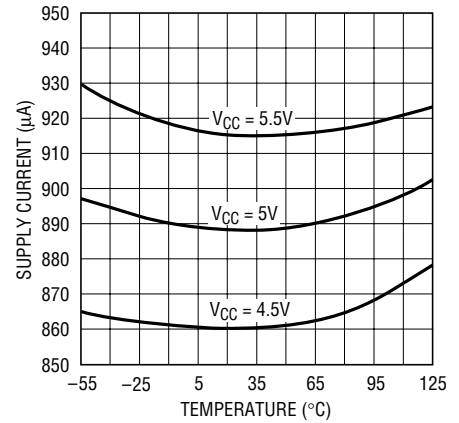

1458 G05

PIN FUNCTIONS

X1/X2 C, X1/X2 D, X1/X2 A, X1/X2 B (Pins 1, 14, 16, 27): The Input Pin that Sets the Gain for DAC C/D/A/B. When grounded the gain will be 2, i.e., output full-scale will be $2 \cdot \text{REFHI}$. When connected to V_{OUT} the gain will be 1, i.e., output full-scale will be equal to REFHI.

$V_{\text{OUT C}}, V_{\text{OUT D}}, V_{\text{OUT A}}, V_{\text{OUT B}}$ (Pins 2, 13, 17, 26): The Buffered DAC Outputs.

$\overline{\text{CS/LD}}$ (Pin 3): The Serial Interface Enable and Load Control Input.

D_{IN} (Pin 4): The Serial Data Input.

REFHI C, REFHI D, REFHI A, REFHI B, (Pins 5, 9, 20, 24): The Inputs to the DAC Resistor Ladder for DAC C/D/A/B.

GND (Pins 6, 23): Ground.

REFLO C, REFLO D, REFLO A, REFLO B, (Pins 7, 8, 21, 22): The Bottom of the DAC Resistor Ladders for the DACs. These can be used to offset zero-scale above ground. REFLO should be connected to ground when no offset is required.

D_{OUT} (Pin 10): The Output of the Shift Register which Becomes Valid on the Rising Edge of the Serial Clock.

CLK (Pin 11): The Serial Interface Clock Input.

V_{CC} (Pins 15, 28): The Positive Supply Input. $4.5\text{V} \leq V_{\text{CC}} \leq 5.5\text{V}$ (LTC1458), $2.7\text{V} \leq V_{\text{CC}} \leq 5.5\text{V}$ (LTC1458L). Requires a $0.1\mu\text{F}$ bypass capacitor to ground.

REFOUT (Pin 19): The Output of the Internal Reference.

$\overline{\text{CLR}}$ (Pin 25): The Clear Pin. Clears all DACs to zero-scale when pulled low.

BLOCK DIAGRAM

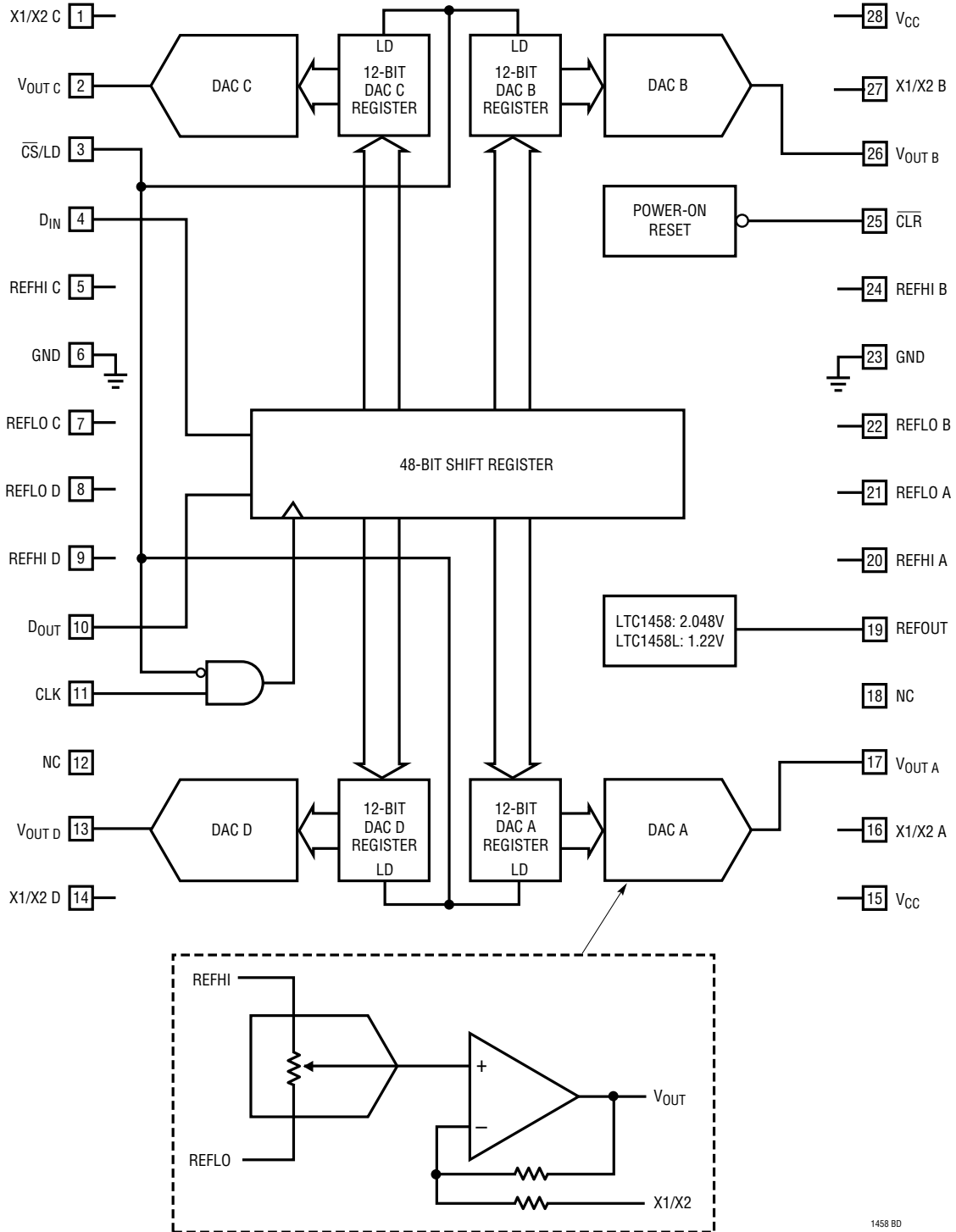

1458 BD

TIMING DIAGRAM

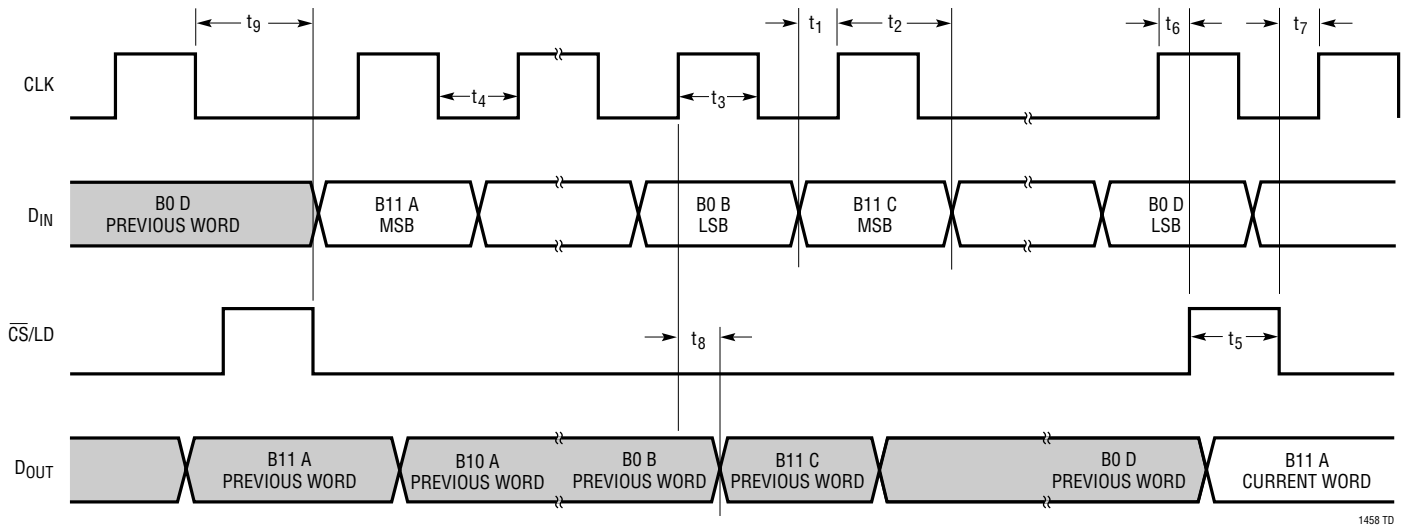

1458 TD

DEFINITIONS

Resolution (n): Resolution is defined as the number of digital input bits, n. It defines the number of DAC output states (2^n) that divide the full-scale range. The resolution does not imply linearity.

Full-Scale Voltage (V_{FS}): This is the output of the DAC when all bits are set to 1.

Voltage Offset Error (V_{OS}): The theoretical voltage at the output when the DAC is loaded with all zeros. The output amplifier can have a true negative offset, but because the part is operated from a single supply, the output cannot go below zero. If the offset is negative, the output will remain near 0V resulting in the transfer curve shown in Figure 1.

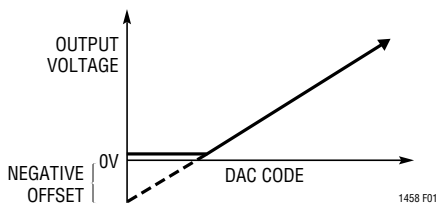

Figure 1. Effect of Negative Offset

The offset of the part is measured at the code that corresponds to the maximum offset specification:

$$V_{OS} = V_{OUT} - [(Code)(V_{FS})/(2^n - 1)]$$

Least Significant Bit (LSB): One LSB is the ideal voltage difference between two successive codes.

$$LSB = (V_{FS} - V_{OS})/(2^n - 1) = (V_{FS} - V_{OS})/4095$$

Nominal LSBs:

$$\begin{aligned} \text{LTC1458} \quad & LSB = 4.095V/4095 = 1mV \\ \text{LTC1458L} \quad & LSB = 2.5V/4095 = 0.610mV \end{aligned}$$

Integral Nonlinearity (INL): End-point INL is the maximum deviation from a straight line passing through the end-points of the DAC transfer curve. Because the part operates from a single supply and the output cannot go below zero, the linearity is measured between full scale and the code corresponding to the maximum offset specification. The INL error at a given input code is calculated as follows:

$$\begin{aligned} INL &= [V_{OUT} - V_{OS} - (V_{FS} - V_{OS})(code/4095)]/LSB \\ V_{OUT} &= \text{The output voltage of the DAC measured at the given input code} \end{aligned}$$

DEFINITIONS

Differential Nonlinearity (DNL): DNL is the difference between the measured change and the ideal 1LSB change between any two adjacent codes. The DNL error between any two codes is calculated as follows:

$$\text{DNL} = (\Delta V_{\text{OUT}} - \text{LSB}) / \text{LSB}$$

ΔV_{OUT} = The measured voltage difference between two adjacent codes

Digital Feedthrough: The glitch that appears at the analog output caused by AC coupling from the digital inputs when they change state. The area of the glitch is specified in (nV)(sec).

OPERATION

Serial Interface

The data on the D_{IN} input is loaded into the shift register on the rising edge of the clock. Data is loaded as one 48-bit word, DAC A first, then DAC B, DAC C and DAC D. The MSB is loaded first for each DAC. The DAC registers load the data from the shift register when $\overline{\text{CS}}/\text{LD}$ is pulled high. The CLK is disabled internally when $\overline{\text{CS}}/\text{LD}$ is high. Note: CLK must be low before $\overline{\text{CS}}/\text{LD}$ is pulled low to avoid an extra internal clock pulse.

The buffered output of the 48-bit shift register is available on the D_{OUT} pin which swings from ground to V_{CC} .

Multiple LTC1458/LTC1458Ls may be daisy-chained together by connecting the D_{OUT} pin to the D_{IN} pin of the next chip, while the CLK and $\overline{\text{CS}}/\text{LD}$ signals remain common to all chips in the daisy-chain. The serial data is clocked to all of the chips, then the $\overline{\text{CS}}/\text{LD}$ signal is pulled high to update all of them simultaneously.

Reference

The LTC1458L has an internal reference of 1.22V with a full scale of 2.5V (gain of 2 configuration). The LTC1458 includes an internal 2.048V reference, making 1LSB equal to 1mV (gain of 2 configuration). When the buffer gain is 2, the external reference must be less than $V_{\text{CC}}/2$ and be capable of driving the 15k minimum DAC resistor ladder. The external reference must always be less than $V_{\text{CC}} - 1.5\text{V}$. The reference output voltage noise spectral density at 1kHz is $300\text{nV}/\sqrt{\text{Hz}}$.

Voltage Output

The rail-to-rail buffered output of the LTC1458 family can source or sink 5mA when operating with a 5V supply over the entire operating temperature range while pulling to within 300mV of the positive supply voltage or ground. The output swings to within a few millivolts of either supply rail when unloaded and has an equivalent output resistance of 40Ω when driving a load to the rails. The output can drive 1000pF without going into oscillation. The output voltage noise spectral density at 1kHz is $600\text{nV}/\sqrt{\text{Hz}}$.

APPLICATIONS INFORMATION

Using Two DACs to Digitally Program the Full Scale and Offset of a Third

Figure 2 shows how to use one LTC1458 to make a 12-bit DAC with a digitally programmable full scale and offset. DAC A and DAC B are used to control the offset and full scale of DAC C. DAC A is connected in a $\times 1$ configuration and controls the offset of DAC C by moving REFLO C above ground. The minimum value to which this offset can be programmed is 10mV. DAC B is connected in a $\times 2$ configuration and controls the full scale of DAC C by driving REFHI C. Note that the voltage at REFHI C must be less than or equal to $V_{CC}/2$, corresponding to DAC B's code

$\leq 2,500$ for $V_{CC} = 5V$, since DAC C is being operated in $\times 2$ mode for full rail-to-rail output swing.

The transfer characteristic is:

$$V_{OUTC} = 2 \cdot [D_C \cdot (2 \cdot D_B - D_A) + D_A] \cdot REF_{OUT}$$

where REF_{OUT} = The Reference Output

$$D_A = (\text{DAC A Digital Code})/4096$$

This sets the offset.

$$D_B = (\text{DAC B Digital Code})/4096$$

This sets the full scale.

$$D_C = (\text{DAC C Digital Code})/4096$$

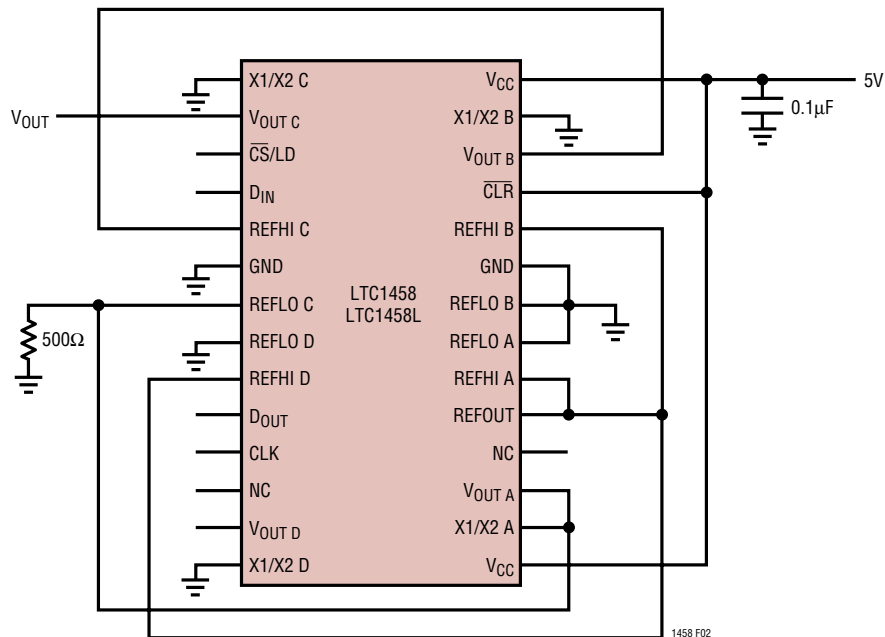
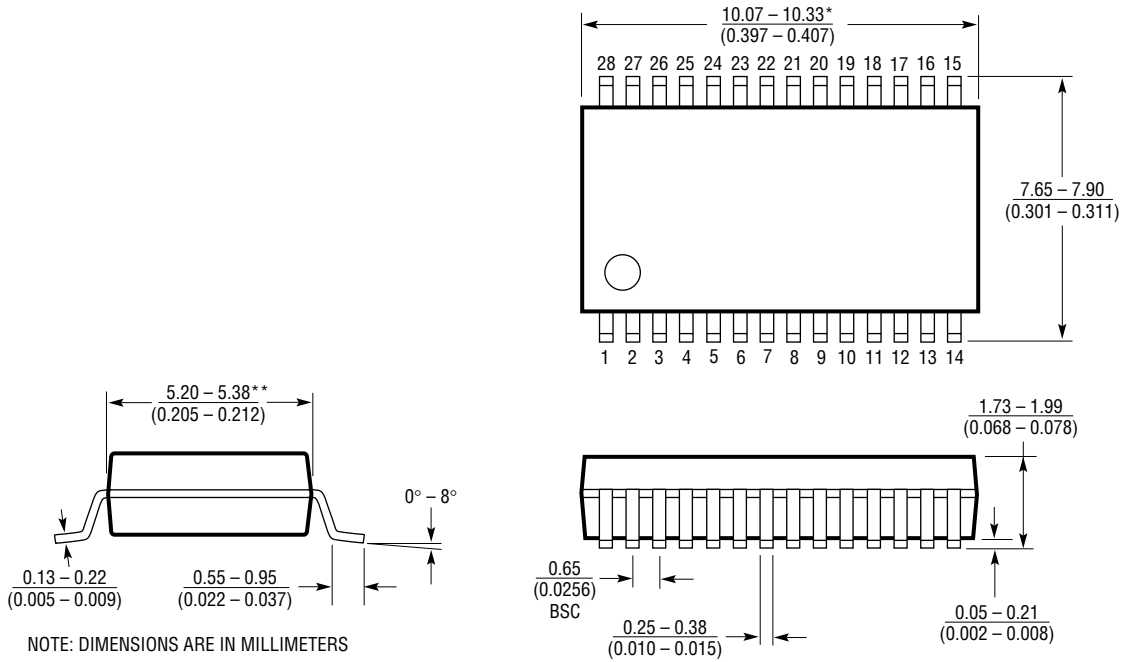

Figure 2

PACKAGE DESCRIPTION Dimensions in inches (millimeters) unless otherwise noted.

G Package
28-Lead Plastic SSOP (0.209)
 (LTC DWG # 05-08-1640)



NOTE: DIMENSIONS ARE IN MILLIMETERS
 *DIMENSIONS DO NOT INCLUDE MOLD FLASH. MOLD FLASH SHALL NOT EXCEED 0.152mm (0.006") PER SIDE
 **DIMENSIONS DO NOT INCLUDE INTERLEAD FLASH. INTERLEAD FLASH SHALL NOT EXCEED 0.254mm (0.010") PER SIDE

G28 SSOP 1098

PACKAGE DESCRIPTION Dimensions in inches (millimeters) unless otherwise noted.

SW Package
28-Lead Plastic Small Outline (Wide 0.300)
 (LTC DWG # 05-08-1620)

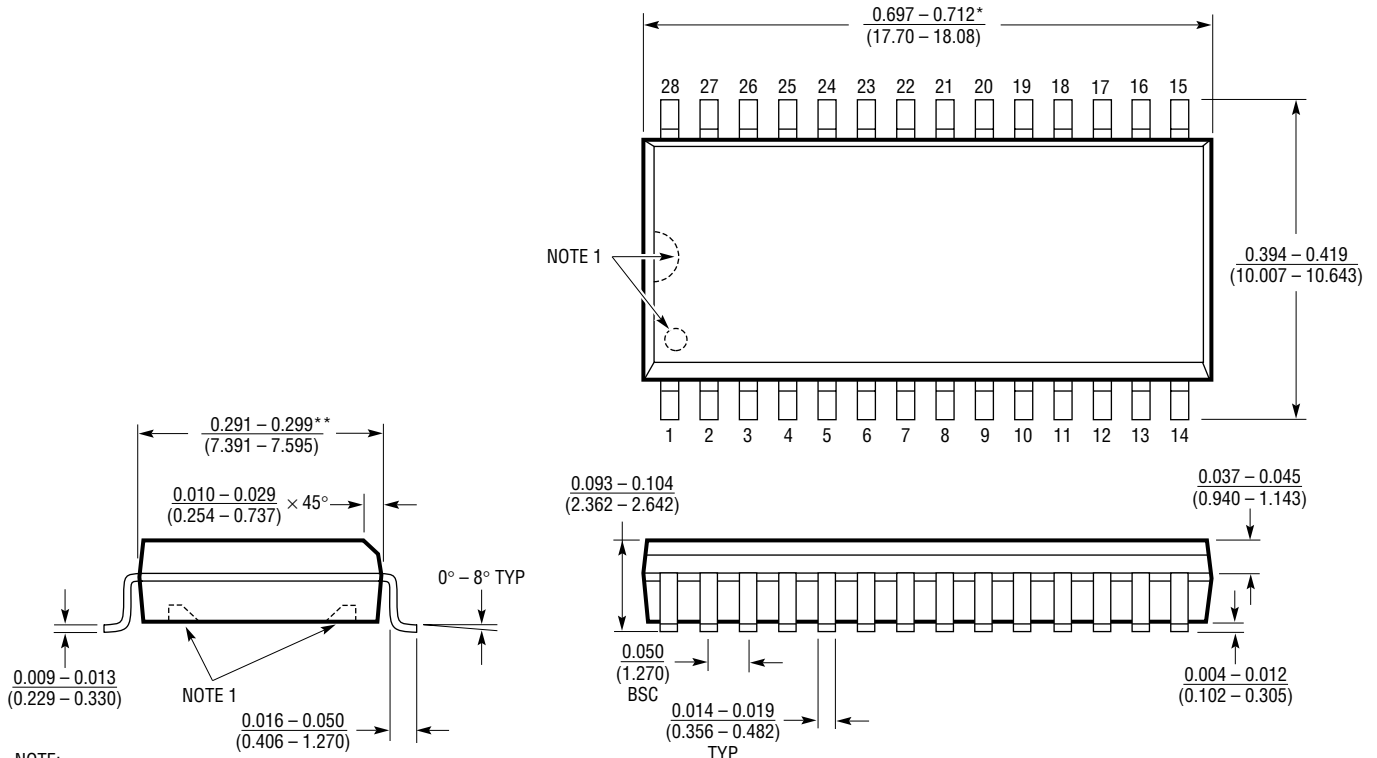

NOTE:
 1. PIN 1 IDENT, NOTCH ON TOP AND CAVITIES ON THE BOTTOM OF PACKAGES ARE THE MANUFACTURING OPTIONS. THE PART MAY BE SUPPLIED WITH OR WITHOUT ANY OF THE OPTIONS
 *DIMENSION DOES NOT INCLUDE MOLD FLASH. MOLD FLASH SHALL NOT EXCEED 0.006" (0.152mm) PER SIDE
 **DIMENSION DOES NOT INCLUDE INTERLEAD FLASH. INTERLEAD FLASH SHALL NOT EXCEED 0.010" (0.254mm) PER SIDE

S28 (WIDE) 1098

LTC1458/LTC1458L

TYPICAL APPLICATION

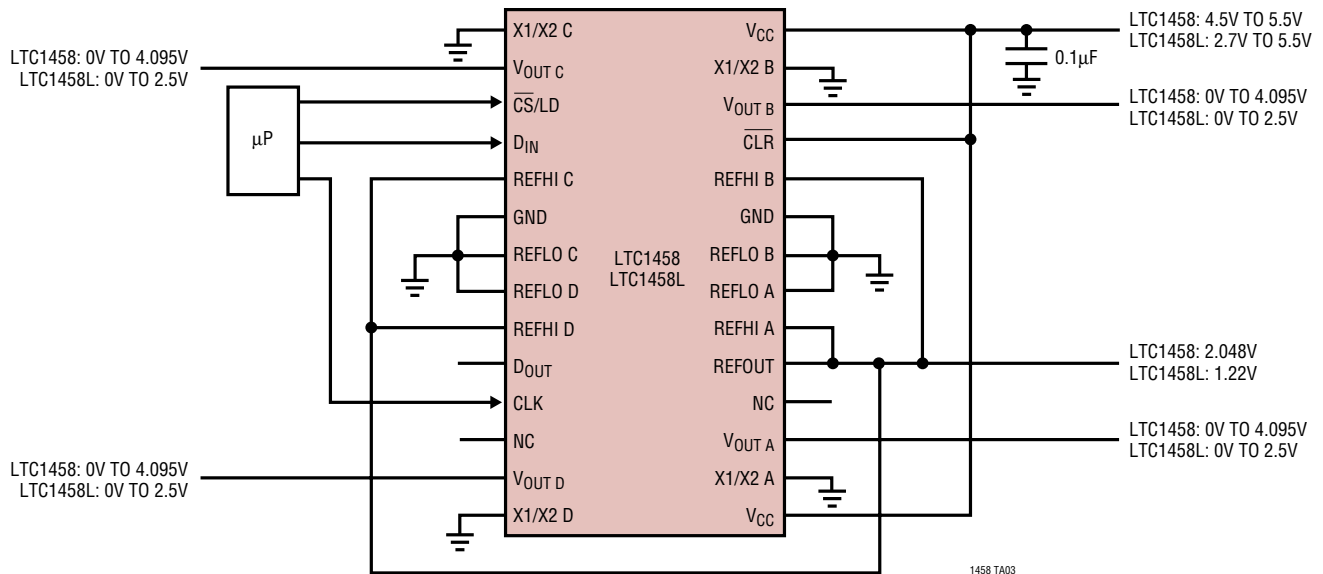

RELATED PARTS

PART NUMBER	DESCRIPTION	COMMENTS
LTC1257	Single 12-Bit V_{OUT} DAC, Full Scale: 2.048V, V_{CC} : 4.75V to 15.75V, Reference Can Be Overdriven up to 12V, i.e., $FS_{MAX} = 12V$	5V to 15V Single Supply, Complete V_{OUT} DAC in SO-8 Package
LTC1446/LTC1446L	Dual 12-Bit Rail-to-Rail Output DACs in SO-8 Package	LTC1446: $V_{CC} = 4.5V$ to 5.5V, $V_{OUT} = 0V$ to 4.095V LTC1446L: $V_{CC} = 2.7V$ to 5.5V, $V_{OUT} = 0V$ to 2.5V
LTC1450/LTC1450L	Single 12-Bit Rail-to-Rail Output DACs with Parallel Interface	LTC1450: $V_{CC} = 4.5V$ to 5.5V, $V_{OUT} = 0V$ to 4.095V LTC1450L: $V_{CC} = 2.7V$ to 5.5V, $V_{OUT} = 0V$ to 2.5V
LTC1451	Single Rail-to-Rail 12-Bit DAC, Full Scale: 4.095V, V_{CC} : 4.5V to 5.5V	Low Power, Complete V_{OUT} DAC in SO-8 Package
LTC1452	Single Rail-to-Rail 12-Bit V_{OUT} Multiplying DAC, V_{CC} : 2.7V to 5.5V	Low Power, Multiplying V_{OUT} DAC with Rail-to-Rail Buffer Amplifier in SO-8 Package
LTC1453	Single Rail-to-Rail 12-Bit V_{OUT} DAC, Full Scale: 2.5V, V_{CC} : 2.7V to 5.5V	3V, Low Power, Complete V_{OUT} DAC in SO-8 Package
LTC1454/LTC1454L	Dual 12-Bit V_{OUT} DACs in SO-16 Package with Added Functionality	LTC1454: $V_{CC} = 4.5V$ to 5.5V, $V_{OUT} = 0V$ to 4.095V LTC1454L: $V_{CC} = 2.7V$ to 5.5V, $V_{OUT} = 0V$ to 2.5V
LTC1456	Single Rail-to-Rail Output 12-Bit DAC with Clear Pin, Full Scale: 4.095V, V_{CC} : 4.5V to 5.5V	Low Power, Complete V_{OUT} DAC in SO-8 Package with Clear Pin
LTC1655/LTC1655L	Single 16-Bit V_{OUT} DAC with Serial Interface in SO-8	$V_{CC} = 5V$ (3V), Low Power, Deglitched, $V_{OUT} = 0V$ to 4.096V (0V to 2.5V)
LTC1661	Dual 10-Bit V_{OUT} DAC in 8-Lead MSOP Package	$V_{CC} = 2.7V$ to 5.5V Micropower, Rail-to-Rail Output
LTC1662	Ultralow Power, Dual 10-Bit DAC in 8-Lead MSOP Package	1.5µA I_{CC} per DAC, 2.7V to 5.5V Supply Range
LTC1664	Quad 10-Bit V_{OUT} DAC in 16-Pin Narrow SSOP	Pin Compatible with the LTC1660, 2.7V to 5.5V Supply Range
LTC1665/LTC1660	Octal 8/10-Bit V_{OUT} DAC in 16-Pin Narrow SSOP	$V_{CC} = 2.7V$ to 5.5V, Micropower, Rail-to-Rail Output

Looking for pricing, stock, or lifecycle information?

Click below to explore more details on WIN SOURCE:

 [View LTC1458LIG#PBF on WIN SOURCE](#)

 [Linear Technology](#) Information

Optimize Your Supply Chain with WIN SOURCE Solutions

-  Global Sourcing Solution
-  Obsolete Management
-  Cost Control Management
-  Shortage Management
-  Alternative Solution
-  Excess Inventory Management