



**THE DATASHEET OF  
LTC1450IG#PBF**



## FEATURES

- **Guaranteed Monotonic**
- **Buffered True Rail-to-Rail Voltage Output**
- 12-Bit Resolution
- 3V Operation (LTC1450L)  $I_{CC}$ : 250 $\mu$ A Typ
- 5V Operation (LTC1450)  $I_{CC}$ : 400 $\mu$ A Typ
- Parallel 12-Bit or 8 + 4-Bit Double Buffered Digital Input
- Internal Reference
- Output Buffer Configurable to Gain of 1 or 2
- Configurable as a Multiplying DAC
- Internal Power-On Reset
- **Maximum DNL Error: 0.5LSB**

## APPLICATIONS

- Digital Calibration
- Industrial Process Control
- Automatic Test Equipment
- Arbitrary Function Generators
- Battery-Powered Data Conversion Products
- Feedback Control Loops and Gain Control

## DESCRIPTION

The LTC<sup>®</sup>1450/LTC1450L are complete single supply, rail-to-rail voltage output, 12-bit digital-to-analog converters (DACs) in a 24-pin SSOP or PDIP package. They include an output buffer amplifier, reference and a double buffered parallel digital interface.

The LTC1450 operates from a 4.5V to 5.5V supply. The output can be pin strapped for 4.095V or 2.048V full-scale. It has a 2.048V internal reference.

The LTC1450L operates from a 2.7V to 5.5V supply. The output can be pin strapped for 2.5V or 1.22V full-scale. It has a 1.22V internal reference.

The LTC1450/LTC1450L offer true stand-alone performance. In addition, the reference output, high and low reference inputs and gain setting resistor are brought to pins for maximum flexibility.

*LTC*, LTC and LT are registered trademarks of Linear Technology Corporation.

## TYPICAL APPLICATION

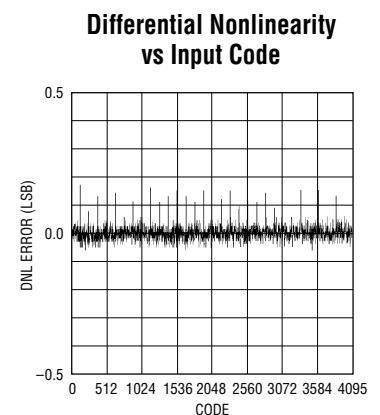
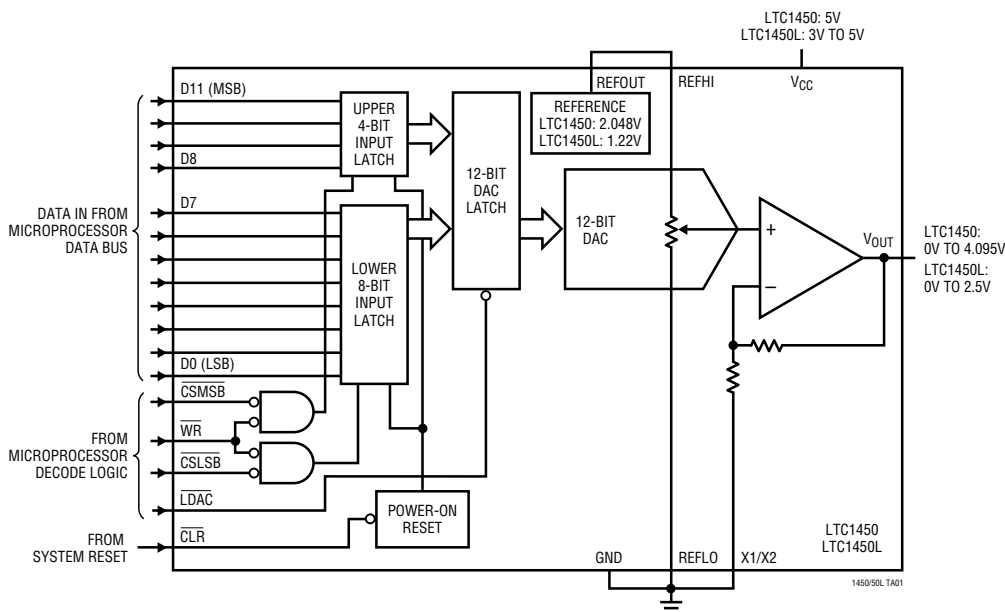

# LTC1450/LTC1450L

## ABSOLUTE MAXIMUM RATINGS

$V_{CC}$ to GND .....	-0.5V to 7.5V
Logic Inputs to GND .....	-0.5V to 7.5V
$V_{OUT}$ .....	-0.5V to $V_{CC} + 0.5V$
REFOUT, REFLO, REFHI, X1/X2 .....	-0.5V to $V_{CC} + 0.5V$
Maximum Junction Temperature .....	125°C
Operating Temperature Range	
Commercial .....	0°C to 70°C
Industrial .....	-40°C to 85°C
Storage Temperature Range .....	-65°C to 150°C
Lead Temperature (Soldering, 10 sec) .....	300°C

## PACKAGE/ORDER INFORMATION

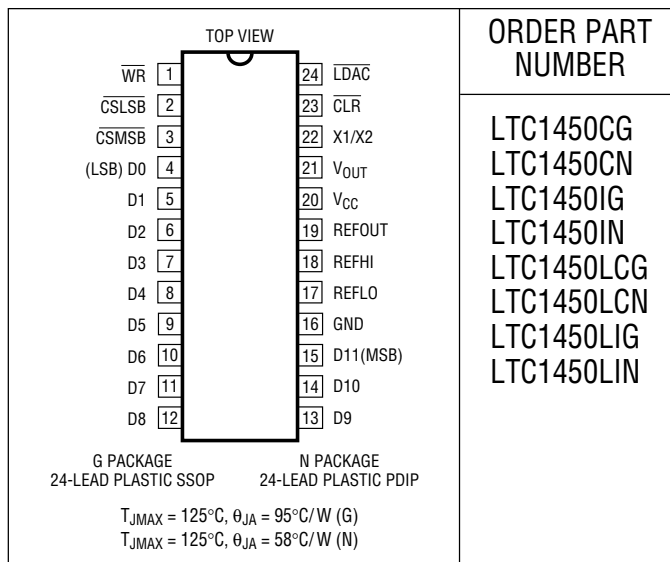

### ORDER PART NUMBER

LTC1450CG  
 LTC1450CN  
 LTC1450IG  
 LTC1450IN  
 LTC1450LCG  
 LTC1450LCN  
 LTC1450LIG  
 LTC1450LIN

Consult factory for Military grade parts.

## ELECTRICAL CHARACTERISTICS

$V_{CC} = 4.5V$  to  $5.5V$  (LTC1450),  $2.7V$  to  $5.5V$  (LTC1450L),  $V_{OUT}$  unloaded,  
 REFOUT = REFHI, REFLO = GND = X1/X2,  $T_A = T_{MIN}$  to  $T_{MAX}$ , unless otherwise noted.

SYMBOL	PARAMETER	CONDITIONS	MIN	TYP	MAX	UNITS	
<b>DAC</b>							
	Resolution		●	12		Bits	
DNL	Differential Nonlinearity	Guaranteed Monotonic (Note 1)	●		±0.5	LSB	
INL	Integral Nonlinearity	$T_A = 25^{\circ}C$ (Note 1)	●		±3.5	LSB	
$V_{OS}$	Offset Error	$T_A = 25^{\circ}C$	●		±12	mV	
			●		±18	mV	
$V_{OS\ TC}$	Offset Error Temperature Coefficient			±15		$\mu V/^{\circ}C$	
$V_{FS}$	Full-Scale Voltage	Using Internal Reference, LTC1450, $T_A = 25^{\circ}C$	●	4.065	4.095	4.125	V
		Using Internal Reference, LTC1450	●	4.045	4.095	4.145	V
		External 2.048V Reference, LTC1450	●	4.075	4.095	4.115	V
		Using Internal Reference, LTC1450L, $T_A = 25^{\circ}C$	●	2.470	2.500	2.530	V
		Using Internal Reference, LTC1450L	●	2.460	2.500	2.540	V
$V_{FS\ TC}$	Full-Scale Voltage Temperature Coefficient	Using Internal Reference, LTC1450			±0.10	LSB/ $^{\circ}C$	
		Using External Reference, LTC1450/LTC1450L			±0.02	LSB/ $^{\circ}C$	
		Using Internal Reference, LTC1450L	●	2.480	2.500	2.520	V
<b>Reference Output (REFOUT)</b>							
	Reference Output Voltage	LTC1450L	●	1.195	1.220	1.245	V
		LTC1450	●	2.008	2.048	2.088	V
	Reference Output Temperature Coefficient			±0.08		LSB/ $^{\circ}C$	
	Reference Line Regulation		●	0.7	±2	LSB/V	
	Reference Load Regulation	$0 \leq I_{OUT} \leq 100\mu A$ , LTC1450L LTC1450	●	0.6	±3.0	LSB	
			●	0.2	±1.5	LSB	
	Short-Circuit Current	REFOUT Shorted to GND	●		80	mA	

## ELECTRICAL CHARACTERISTICS

$V_{CC} = 4.5V$  to  $5.5V$  (LTC1450),  $2.7V$  to  $5.5V$  (LTC1450L),  $V_{OUT}$  unloaded,  $REF_{OUT} = REF_{HI}$ ,  $REF_{LO} = GND = X1/X2$ ,  $T_A = T_{MIN}$  to  $T_{MAX}$ , unless otherwise noted.

SYMBOL	PARAMETER	CONDITIONS		MIN	TYP	MAX	UNITS
<b>Reference Input (REFLO = GND)</b>							
	REFHI Input Range	$V_{REFHI} \leq V_{CC} - 1.5V$	●			$V_{CC}/2$	V
	REFHI Input Resistance		●	8	18	30	k $\Omega$
	REFHI Input Capacitance				15		pF
<b>Power Supply</b>							
$V_{CC}$	Positive Supply Voltage	For Specified Performance, LTC1450L LTC1450	● ●	2.7 4.5		5.5 5.5	V V
$I_{CC}$	Supply Current	$4.5V \leq V_{CC} \leq 5.5V$ (Note 4) LTC1450 $2.7V \leq V_{CC} \leq 5.5V$ (Note 4) LTC1450L	● ●	300 150	400 250	620 500	$\mu A$ $\mu A$
<b>Op Amp DC Performance</b>							
	Short-Circuit Current Low	$V_{OUT}$ Shorted to GND	●			100	mA
	Short-Circuit Current High	$V_{OUT}$ Shorted to $V_{CC}$	●			120	mA
	Output Impedance to GND	Input Code = 0	●		40	120	$\Omega$
<b>AC Performance</b>							
	Voltage Output Slew Rate	(Note 2)	●	0.5	1.0		V/ $\mu s$
	Voltage Output Settling Time	(Notes 2, 3) to $\pm 0.5LSB$			14		$\mu s$
	Digital Feedthrough	LDAC = 1			5		(nV)(s)
	AC Feedthrough	REFHI = 1kHz, $2V_{P-P}$			-95		dB
SINAD	Signal-to-Noise + Distortion	REFHI = 1kHz, $2V_{P-P}$ (Code: All 1's)			85		dB
<b>Digital Inputs</b>							
$V_{IH}$	Digital Input High Voltage	$V_{CC} = 3V$ , LTC1450L $V_{CC} = 5V$ , LTC1450	● ●	2.2 2.4			V V
$V_{IL}$	Digital Input Low Voltage	$V_{CC} = 3V$ , LTC1450L $V_{CC} = 5V$ , LTC1450	● ●			0.8 0.8	V V
$V_{LTH}$	Logic Threshold Voltage	LTC1450L			$V_{CC}/2$		V
$I_{LEAK}$	Digital Input Leakage	$V_{CC} = 5V$ , $V_{IN} = GND$ to $V_{CC}$	●	-10		10	$\mu A$
$C_{IN}$	Digital Input Capacitance	Guaranteed by Design. Not Subject to Test	●			10	pF

# LTC1450/LTC1450L

## ELECTRICAL CHARACTERISTICS

$V_{CC} = 4.5V$  to  $5.5V$  (LTC1450),  $V_{CC} = 2.7V$  to  $3.6V$  (LTC1450L),  $T_A = T_{MIN}$  to  $T_{MAX}$ , unless otherwise noted.

SYMBOL	PARAMETER	CONDITIONS	MIN	TYP	MAX	UNITS
<b>Switching Characteristics (Note 5)</b>						
$t_{CS}$	$\overline{CS}$ (MSB or LSB) Pulse Width		●	40		ns
$t_{WR}$	$\overline{WR}$ Pulse Width		●	40		ns
$t_{CWS}$	$\overline{CS}$ to $\overline{WR}$ Setup		●	0		ns
$t_{CWH}$	$\overline{CS}$ to $\overline{WR}$ Hold		●	0		ns
$t_{DWS}$	Data Valid to $\overline{WR}$ Setup	$V_{CC} = 4.5V$ to $5.5V$ (LTC1450)	●	40	15	ns
		$V_{CC} = 2.7V$ to $3.6V$ (LTC1450L)	●	40	15	ns
		$V_{CC} = 5V$ (LTC1450L)			10	ns
$t_{DWH}$	Data Valid to $\overline{WR}$ Hold	$V_{CC} = 4.5V$ to $5.5V$ (LTC1450)	●	0	-10	ns
		$V_{CC} = 2.7V$ to $3.6V$ (LTC1450L)	●	0	-10	ns
		$V_{CC} = 5V$ (LTC1450L)			-5	ns
$t_{LDAC}$	$\overline{LDAC}$ Pulse Width		●	40		ns
$t_{CLR}$	$\overline{CLR}$ Pulse Width		●	40		ns

The ● denotes specifications which apply over the full operating temperature range.

**Note 1:** Nonlinearity is defined from the first code that is greater than or equal to the maximum offset specification to code 4095 (full-scale).

**Note 2:** Load is  $5k\Omega$  in parallel with  $100pF$ .

**Note 3:** DAC switched all 1's and the code corresponding to  $V_{OS(MAX)}$  for the part.

**Note 4:** Digital inputs at  $0V$  or  $V_{CC}$ .

**Note 5:** Digital inputs swing 10% to 90% of  $V_{CC}$ ,  $t_r = t_f = 5ns$  and timing measurements are from  $V_{CC}/2$ .

## TYPICAL PERFORMANCE CHARACTERISTICS

**Minimum Supply Voltage vs Load Current**

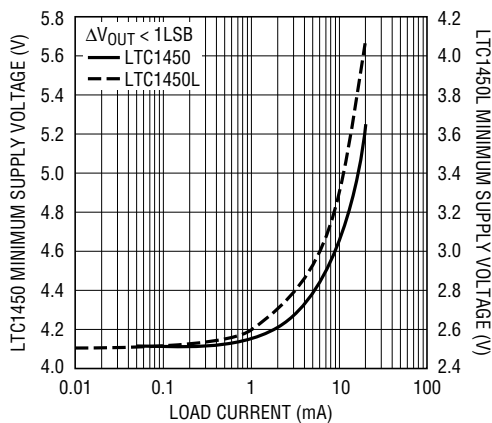

1450/50L G01

**LTC1450 Supply Current vs Temperature**

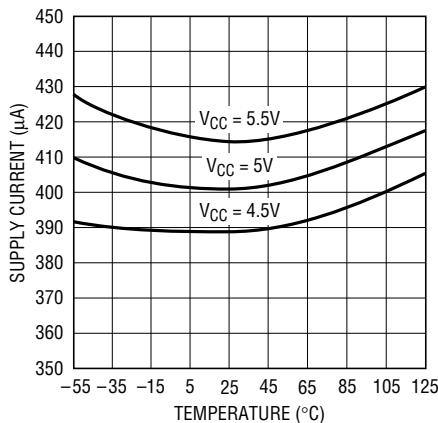

1450/50L G02

**Supply Current vs Logic Input Voltage**

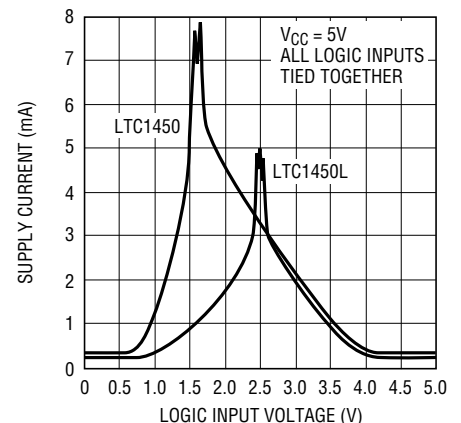

1450/50L G03

# TYPICAL PERFORMANCE CHARACTERISTICS

**LTC1450L Supply Current vs Logic Input Voltage**

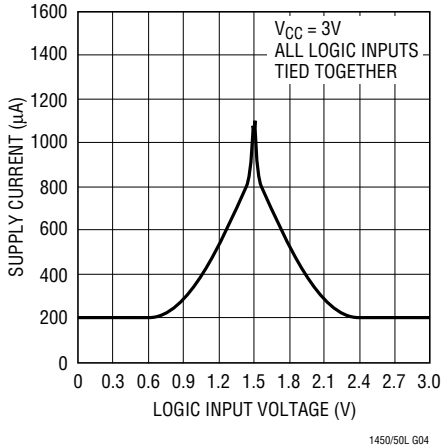

**LTC1450 Output Swing vs Load Resistance**

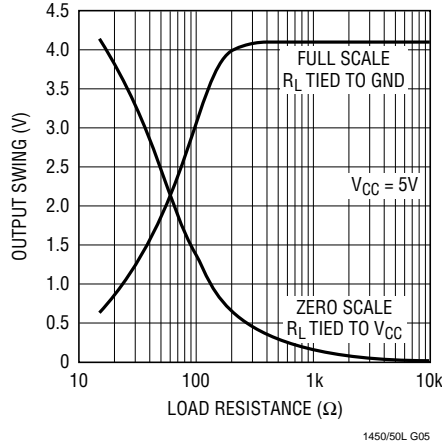

**LTC1450 Pull-Down Voltage vs Output Sink Current Capability**

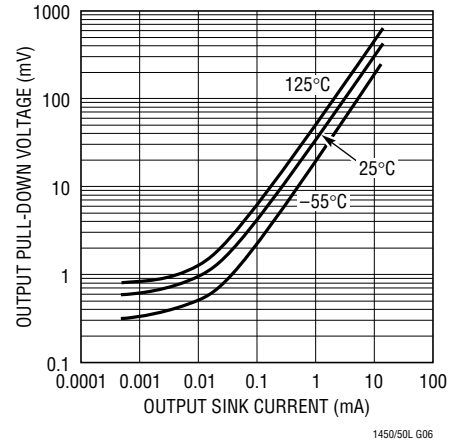

**LTC1450 Output Offset Voltage vs Temperature**

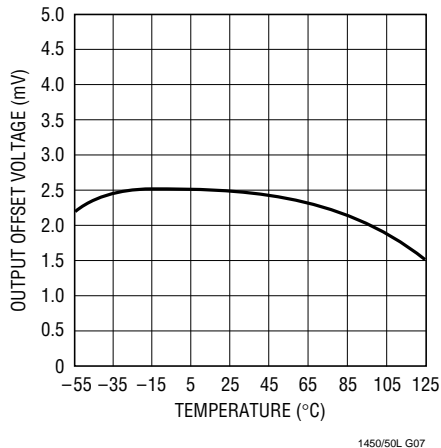

**LTC1450 Differential Nonlinearity (DNL)**

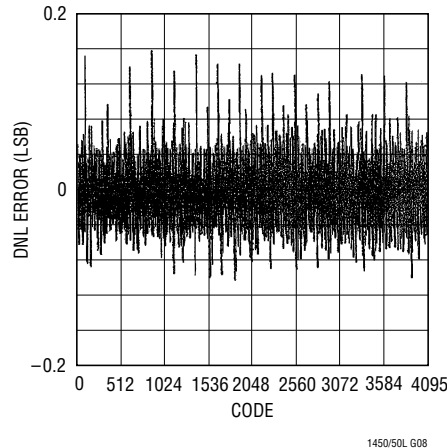

**LTC1450 Integral Nonlinearity (INL)**

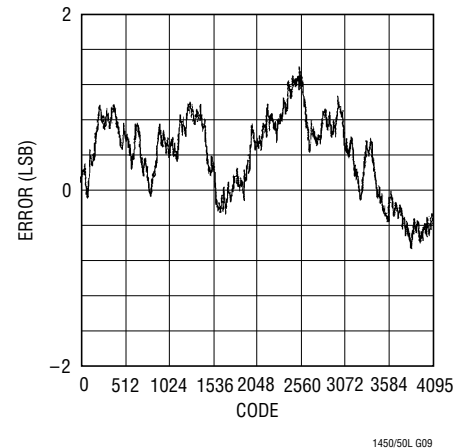

**Power Supply Rejection vs Frequency**

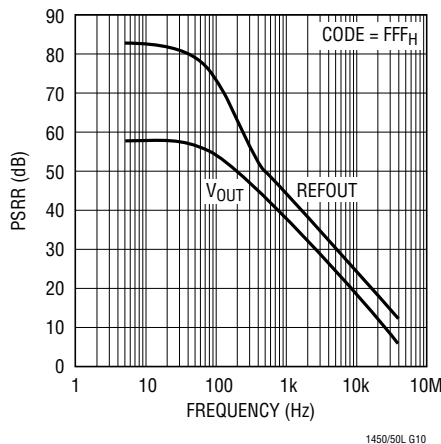

**LTC1450 Total Harmonic Distortion + Noise vs Frequency**

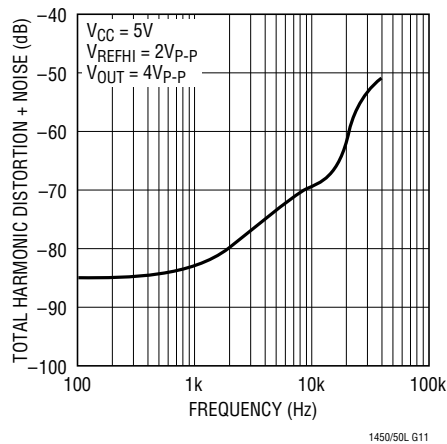

**LTC1450 Broadband Output Noise**

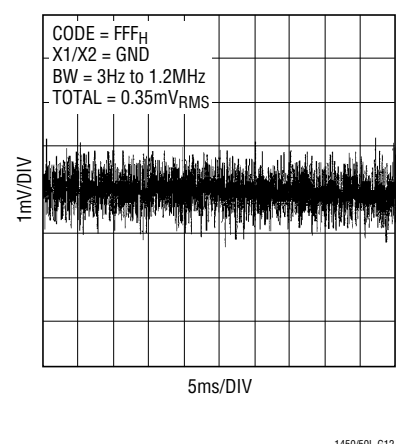

## TYPICAL PERFORMANCE CHARACTERISTICS

**LTC1450 Midscale Transition**  
Data = 2048 to 2047

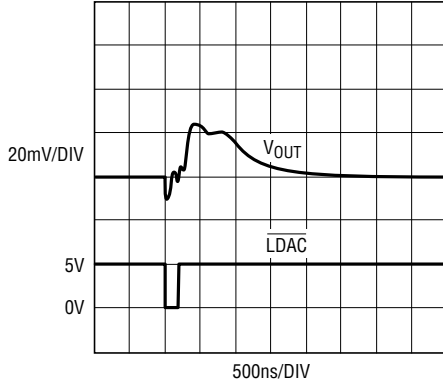

1450/50L G13

**LTC1450 Large-Scale Settling (Rising)**

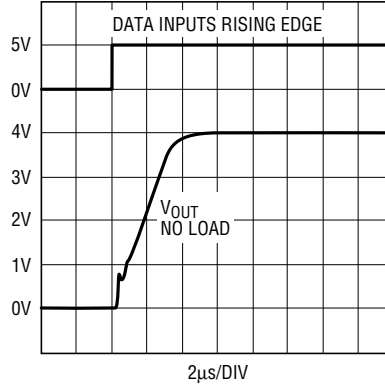

1450/50L G14

**LTC1450 Large-Scale Settling (Falling)**

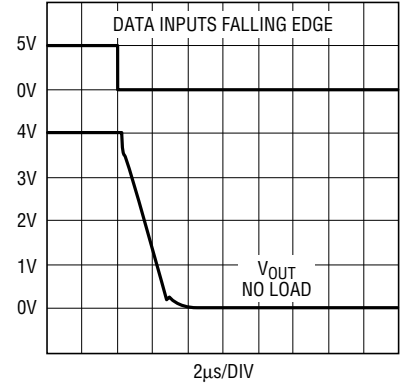

1450/50L G15

**Output Voltage Full-Scale Settling**

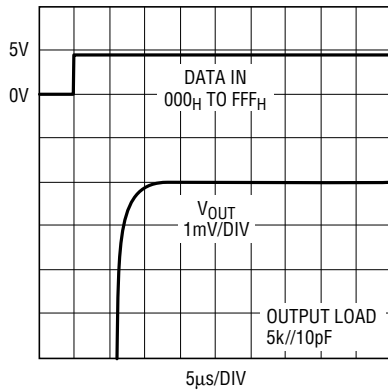

1450/50L G16

**Output Voltage Zero-Scale Settling**

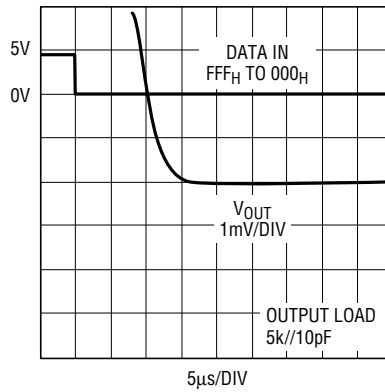

1450/50L G17

**LTC1450 Digital Feedthrough**

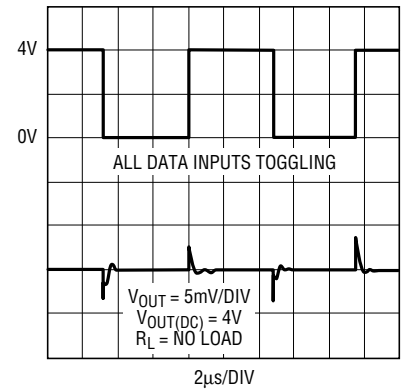

1450/50L G18

## PIN FUNCTIONS

**WR (Pin 1):** Write Input (Active Low). Used with  $\overline{\text{CSMSB}}$  and/or  $\overline{\text{CSLSB}}$  to load data into the input latches. While  $\overline{\text{WR}}$  and  $\overline{\text{CSMSB}}$  and/or  $\overline{\text{CSLSB}}$  are held low the enabled input latches are transparent. The rising edge of  $\overline{\text{WR}}$  will latch data into all input latches.

**CSLSB (Pin 2):** Chip Select Least Significant Byte (Active Low). Used with  $\overline{\text{WR}}$  to load data into the eight LSB input latches. While  $\overline{\text{WR}}$  and  $\overline{\text{CSLSB}}$  are held low the eight LSB input latches are transparent. The rising edge will latch data into the eight LSB input latches. Can be connected to  $\overline{\text{CSMSB}}$  for simultaneous loading of both sets of input latches on a 12-bit bus.

**CSMSB (Pin 3):** Chip Select Most Significant Byte (Active Low). Used with  $\overline{\text{WR}}$  to load data into the four MSB input latches. While  $\overline{\text{WR}}$  and  $\overline{\text{CSMSB}}$  are held low the four MSB input latches are transparent. The rising edge will latch data into the four MSB input latches. Can be connected to  $\overline{\text{CSLSB}}$  for simultaneous loading of both sets of input latches on a 12-bit bus.

**D0 to D7 (Pins 4 to 11):** Input data for the Least Significant Byte. Loaded into LSB input latch when  $\overline{\text{WR}} = 0$  and  $\overline{\text{CSLSB}} = 0$ .

**D8, D9, D10, D11 (Pins 12, 13, 14, 15):** Input data for the Most Significant Byte. Loaded into MSB input latch when  $\overline{\text{WR}} = 0$  and  $\overline{\text{CSMSB}} = 0$ . Can be connected to D0 to D3 for multiplexed operation on an 8-bit bus.

**GND (Pin 16):** Ground.

**REFLO (Pin 17):** Lower input terminal of the DAC's internal resistor string. Typically connected to Analog Ground.

An input code of (000<sub>H</sub>) will connect the positive input of the output buffer to this end. Can be used to offset the zero scale above ground.

**REFHI (Pin 18):** Upper input terminal of the DAC's internal resistor string. Typically connected to REFOUT. An input code of (FFF<sub>H</sub>) will connect the positive input of the output buffer to 1LSB from this end.

**REFOUT (Pin 19):** Output of the internal 2.048V/1.22V reference. Typically connected to REFHI to drive internal DAC resistor string.

**V<sub>CC</sub> (Pin 20):** Positive Power Supply Input.  $4.5\text{V} \leq V_{\text{CC}} \leq 5.5\text{V}$  (LTC1450) and  $2.7\text{V} \leq V_{\text{CC}} \leq 5.5\text{V}$  (LTC1450L). Requires a bypass capacitor to ground.

**V<sub>OUT</sub> (Pin 21):** Buffered DAC Output.

**X1/X2 (Pin 22):** Gain Setting Resistor Pin. Connect to GND for  $G = 2$  or to  $V_{\text{OUT}}$  for  $G = 1$ . Should always be tied to a low impedance source, such as ground or  $V_{\text{OUT}}$ , to ensure stability of the output buffer when driving capacitive loads.

**CLR (Pin 23):** Clear Input (Asynchronous Active Low). A low on this pin asynchronously resets all internal latches to 0s.

**LDAC (Pin 24):** Load DAC (Asynchronous Active Low). Used to asynchronously transfer the contents of the input latches to the DAC latches which updates the output voltage. The rising edge latches the data into the DAC latches. If held low the DAC latches are transparent and data from the input latches will immediately update  $V_{\text{OUT}}$ .

## DIGITAL INTERFACE TRUTH TABLE

CLR	CSMSB	CSLSB	WR	LDAC	FUNCTION
H	H	L	L	H	Loads the eight LSBs into the input latch
H	H	L	↑	H	Latches the eight LSBs into the input latch
H	H	↑	L	H	Latches the eight LSBs into the input latch
H	L	H	L	H	Loads the four MSBs into the input latch
H	L	H	↑	H	Latches the four MSBs into the input latch
H	↑	H	L	H	Latches the four MSBs into the input latch
H	H	H	H	L	Loads the input latch data into the DAC latch
H	H	H	H	↑	Latches the input latch data into the DAC latch
H	L	L	L	L	Loads input data into DAC latches (latches transparent)
H	L	L	L	↑	Latches input data into DAC latches
L	X	X	X	X	All zeros loaded into input and DAC latches

## TIMING DIAGRAM

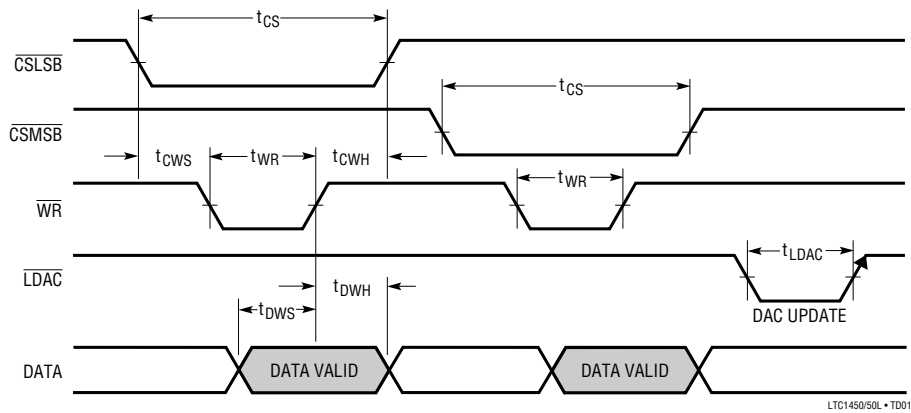

LTC1450/50L • TD01

## BLOCK DIAGRAM

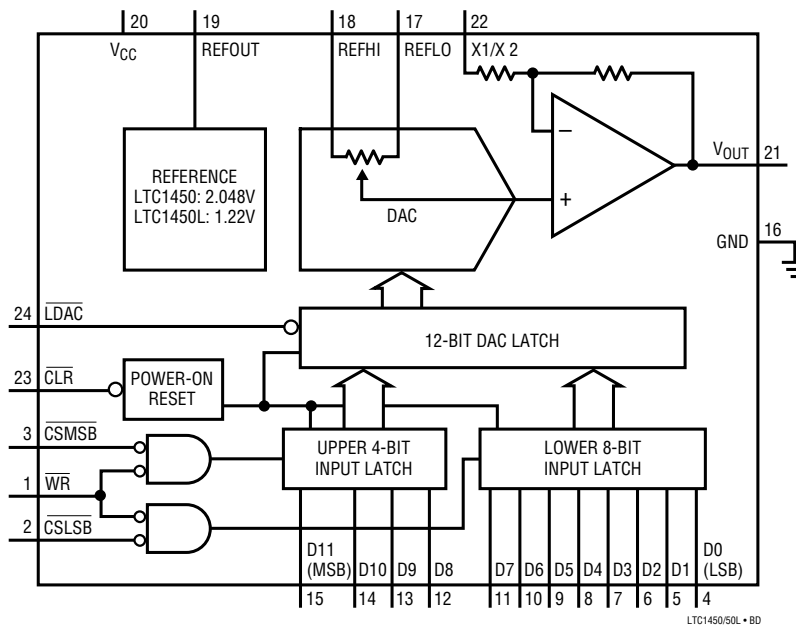

LTC1450/50L • BD

## DEFINITIONS

**Resolution (n):** Resolution is defined as the number of digital input bits (n). It defines the number of DAC output states ( $2^n$ ) that divide the full-scale range. The resolution does not imply linearity.

**Full-Scale Voltage ( $V_{FS}$ ):** This is the output of the DAC when all bits are set to 1.

**Voltage Offset Error ( $V_{OS}$ ):** The theoretical voltage at the output when the DAC is loaded with all zeros. The output amplifier can have a true negative offset, but because the part is operated from a single supply, the output cannot go below zero. If the offset is negative, the output will remain near 0V resulting in the transfer curve shown in Figure 1.

The offset of the part is measured at the code that corresponds to the maximum offset specification:

$$V_{OS} = V_{OUT} - [(Code)(V_{FS})/(2^n - 1)]$$

**Least Significant Bit (LSB):** One LSB is the ideal voltage difference between two successive codes.

$$LSB = (V_{FS} - V_{OS})/(2^n - 1) = (V_{FS} - V_{OS})/4095$$

Nominal LSBs:

$$\text{LTC1450} \quad LSB = 4.095V/4095 = 1mV$$

$$\text{LTC1450L} \quad LSB = 2.5V/4095 = 0.610mV$$

**Integral Nonlinearity (INL):** End-point INL is the maximum deviation from a straight line passing through the end points of the DAC transfer curve. Because the part operates from a single supply and the output cannot go below zero, the linearity is measured between full scale and the code corresponding to the maximum offset specification. The INL error at a given input code is calculated as follows:

$$INL = [V_{OUT} - V_{OS} - (V_{FS} - V_{OS})(code/4095)]/LSB$$

$V_{OUT}$  = The output voltage of the DAC measured at the given input code

**Differential Nonlinearity (DNL):** DNL is the difference between the measured change and the ideal one LSB change between any two adjacent codes. The DNL error between any two codes is calculated as follows:

$$DNL = (\Delta V_{OUT} - LSB)/LSB$$

$\Delta V_{OUT}$  = The measured voltage difference between two adjacent codes

**Digital Feedthrough:** The glitch that appears at the analog output caused by AC coupling from the digital inputs when they change state. The area of the glitch is specified in (nV)(s).

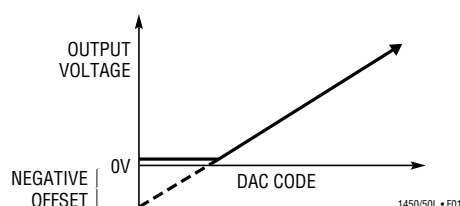

Figure 1. Effect of Negative Offset

## OPERATION

### Parallel Interface

The data on the input of the DAC is loaded into the DAC's input latches when Chip Select ( $\overline{\text{CSLSB}}$  and/or  $\overline{\text{CSMSB}}$ ) and  $\overline{\text{WR}}$  are at a logic low. The data that is loaded into the input latches will depend on which of the Chip Selects are at a logic low (see Digital Interface Truth Table). If  $\overline{\text{WR}}$  and  $\overline{\text{CSLSB}}$  are both low and  $\overline{\text{CSMSB}}$  is high, then only data on the eight LSBs (D0 to D7) is loaded into the input latches. Similarly if  $\overline{\text{WR}}$  and  $\overline{\text{CSMSB}}$  are both low and  $\overline{\text{CSLSB}}$  is high then only data on the four MSBs (D8 to D11) is loaded into the input latches. Data is loaded into both the Least Significant Data Bits (D0 to D7) and the Most Significant Bits (D8 to D11) at the same time if  $\overline{\text{WR}}$ ,  $\overline{\text{CSLSB}}$  and  $\overline{\text{CSMSB}}$  are low.

The input data is latched into the input latches on the rising edge of either the  $\overline{\text{WR}}$  or one of the Chip Selects. The  $\overline{\text{WR}}$  transition high will latch the data in both input latches. A rising edge on  $\overline{\text{CSMSB}}$  will latch data bits D8 to D11. A rising edge on  $\overline{\text{CSLSB}}$  will latch data bits D0 to D7.

Once data is loaded into the input latches, it can be loaded into the DAC latch. This will update the analog voltage output of the DAC. The DAC latch is loaded by a logic low on  $\overline{\text{LDAC}}$ . The data that is loaded into the DAC latch will be latched on the rising edge of  $\overline{\text{LDAC}}$ .

When  $\overline{\text{WR}}$ ,  $\overline{\text{CSLSB}}$ ,  $\overline{\text{CSMSB}}$  and  $\overline{\text{LDAC}}$  are all low the latches are transparent and data on pins D0 to D11 loads directly into the DAC latch.

### Power-On Reset

The LTC1450/LTC1450L have an internal power-on reset that resets all internal latches to 0's on power-up (equivalent to the  $\overline{\text{CLR}}$  pin function).

### Reference

The LTC1450 includes an internal 2.048V reference, giving the LTC1450 a full-scale range of 4.095V in the gain of 2 configuration. The LTC1450L has an internal 1.22V reference with a full-scale range of 2.5V and a gain of 2.05 in the gain of 2 configuration. The onboard reference in the LTC1450 and LTC1450L is not internally connected to the DAC's reference resistor string but is provided on an adjacent pin for flexibility. Because the internal reference

is not internally connected to the DAC resistor string, an external reference can be used or the resistor string can be driven with an external source in multiplying configuration. The external reference or source must be capable of driving the 8k minimum DAC ladder resistance.

The reference output noise can be reduced with a bypass capacitor to ground. (Note: The reference does not require a bypass capacitor to ground for proper operation.) When bypassing the reference a small value resistor in series with the capacitor is recommended to help reduce peaking on the output. A 10 $\Omega$  resistor in series with a 4.7 $\mu\text{F}$  capacitor is optimum for reducing reference generated noise.

### DAC Ladder Resistor String

The high and low end of the DAC ladder resistor string (REFHI and REFLO respectively) are not connected internally on this part. Typically REFHI will be connected to REFOUT and REFLO will be connected to GND. This will give the LTC1450 a full-scale range of 4.095V. The full-scale range for the LTC1450L will be 2.5V

Either of these pins can be driven up to  $V_{\text{CC}} - 1.5\text{V}$  when using the buffer in the gain of 1 configuration. The resistor string pins can be driven to  $V_{\text{CC}}/2$  when the buffer is in the gain of 2 configuration (2.05 for the LTC1450L). The resistance between these two pins is typically 18k (8k min).

### Voltage Output

The output buffer for the LTC1450/LTC1450L can be configured for two different gain settings. By tying the X1/X2 pin to GND the gain is set to 2 (2.05 for the LTC1450L). By tying the X1/X2 pin to  $V_{\text{OUT}}$  the gain is set to one.

The LTC1450 family's rail-to-rail buffered output can source or sink 5mA over the entire operating temperature range while pulling to within 300mV of the positive supply voltage or GND. The output swings to within a few millivolts of either supply rail when unloaded and has an equivalent output resistance of 40 $\Omega$  when driving a load to the rails.

## TYPICAL APPLICATIONS

### Filter $V_{REF}$ to Lower Output Noise (0.18mV<sub>RMS</sub> at $V_{OUT}$ )

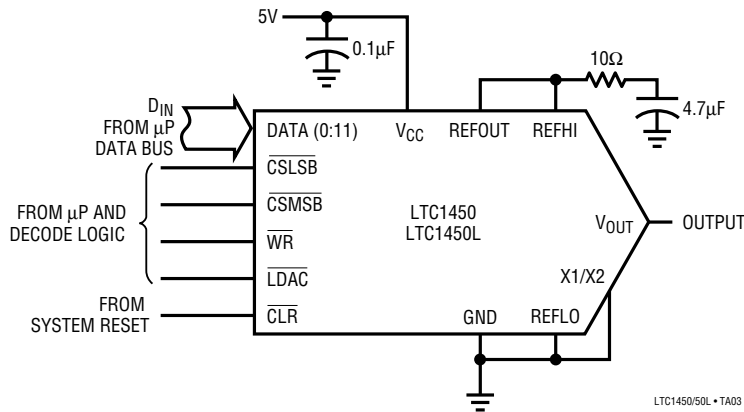

### Digitally Programmable Noninverting Amplifier

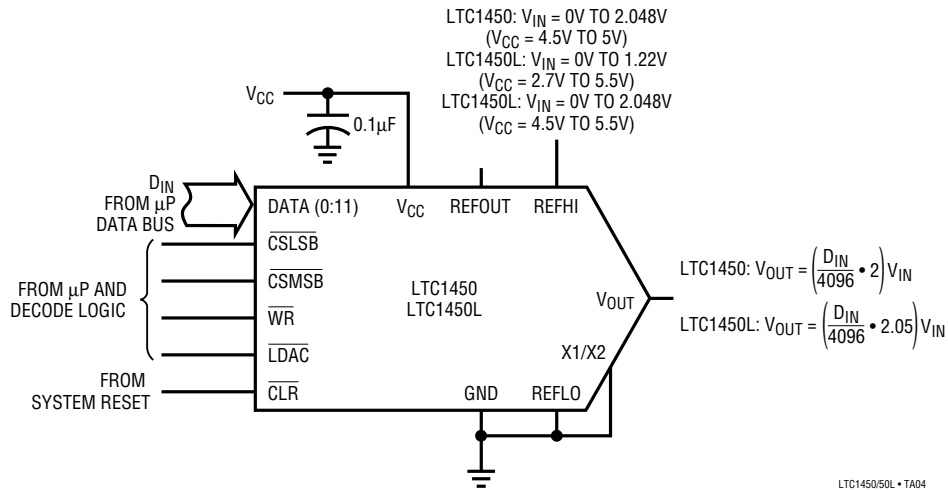

## TYPICAL APPLICATIONS

### Bipolar Output 12-Bit DAC

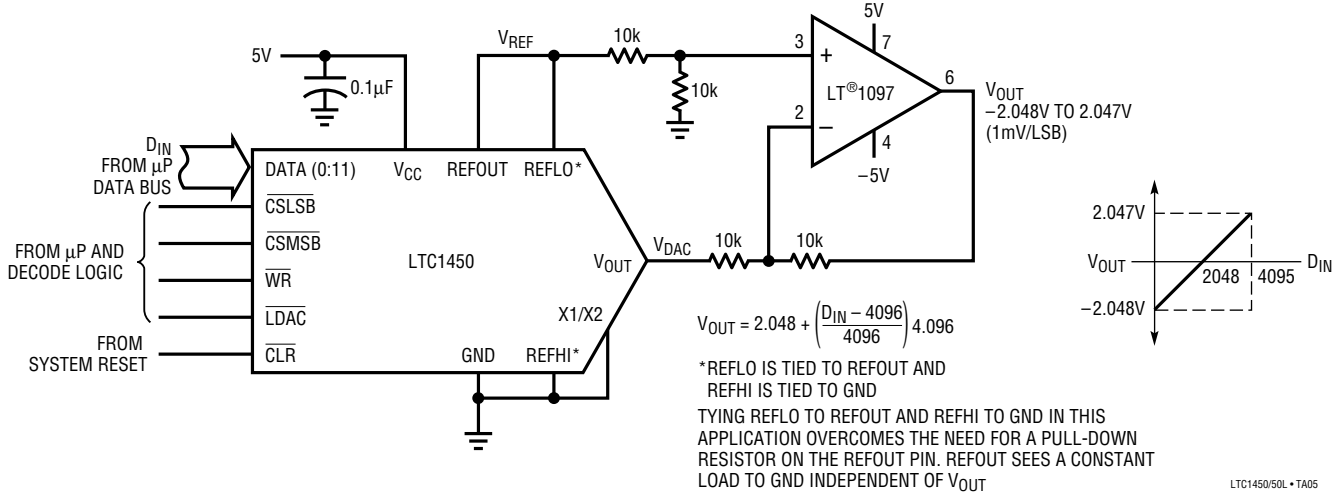

### Digitally Programmable Bilateral Current Source/Sink

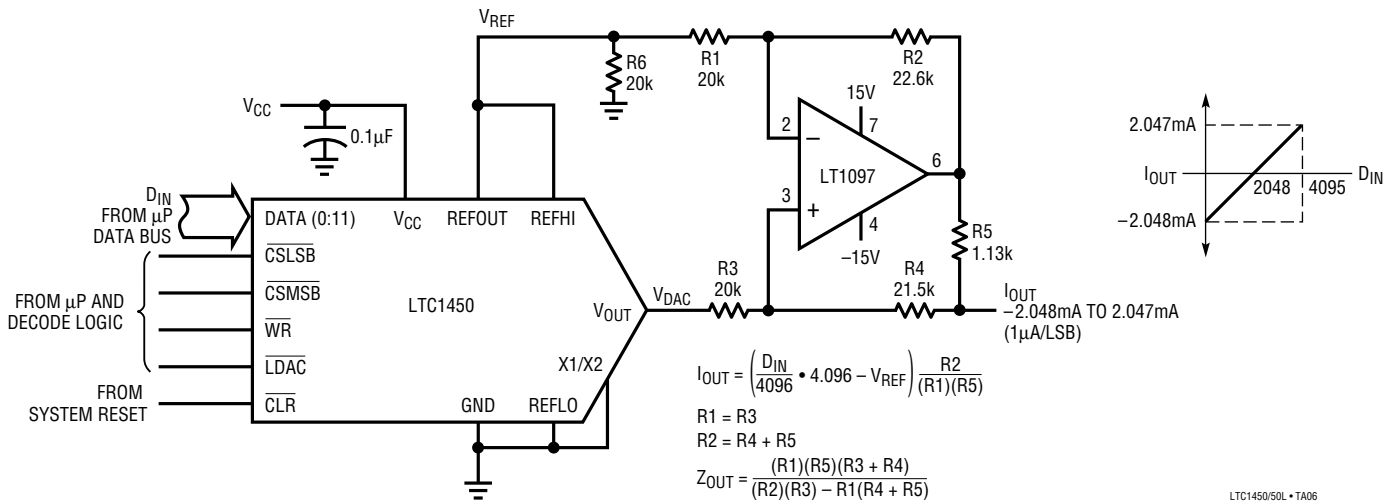

## TYPICAL APPLICATIONS

### 4-Quadrant Multiplying DAC Application

This application shows the LTC1450L configured as a single supply 4-quadrant multiplying DAC. It uses a 5V supply and only one external component, a 5k resistor tied from REFOUT to ground. (The LTC1450 can be used in a similar fashion.) The multiplying DAC allows the user to digitally change the amplitude and polarity of an AC input signal whose voltage is centered around an offset signal ground provided by the 1.22V reference voltage. The transfer function is shown in the following equations.

$$V_{OUT} = (V_{IN} - V_{REF}) \left[ \text{Gain} \left( \frac{D_{IN}}{4096} - 1 \right) + 1 \right] + V_{REF}$$

For the LTC1450L Gain = 2.05 and  $V_{REF} = 1.22V$

$$V_{OUT} = (V_{IN} - 1.22V) \left[ 2.05 \left( \frac{D_{IN}}{4096} \right) - 1.05 \right] + 1.22V$$

Table 1 shows the expressions for  $V_{OUT}$  as a function of  $V_{IN}$ ,  $V_{REF}$  and  $D_{IN}$ . The scope photo shows a 12.5kHz, 2.3V<sub>P-P</sub> triangle wave input signal and the corresponding output waveforms for zero-scale and full-scale DAC codes.

**Table 1. Binary Code Table for 4-Quadrant, Multiplying DAC Application**

BINARY DIGITAL INPUT CODE IN DAC REGISTER		ANALOG OUTPUT ( $V_{OUT}$ )
MSB	LSB	
1111	1111	$(4094/4096)(V_{IN} - V_{REF}) + V_{REF}$
1100	0001	$0.5(V_{IN} - V_{REF}) + V_{REF}$
1000	0011	$V_{REF}$
0100	0100	$-0.5(V_{IN} - V_{REF}) + V_{REF}$
0000	0110	$-1.0(V_{IN} - V_{REF}) + V_{REF}$
0000	0000	$-1.05(V_{IN} - V_{REF}) + V_{REF}$

**Clean 4-Quadrant Multiplying Is Shown in the Output Waveforms for Zero-Scale and Full-Scale DAC Settings**

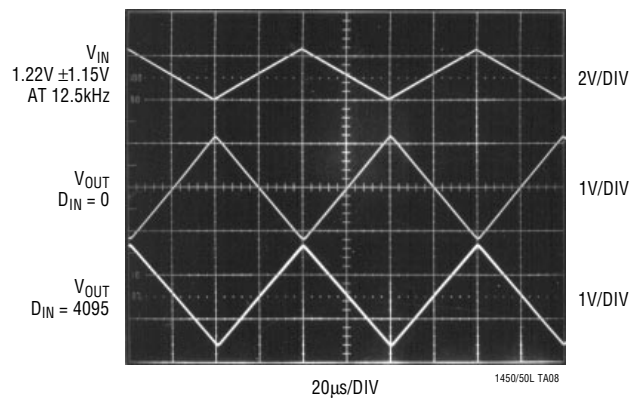

**Internal Reference, REFLO/REFHI Pins, Gain Adjust and Wide Supply Voltage Range Allow 4-Quadrant Multiplying on a 5V Single Supply**

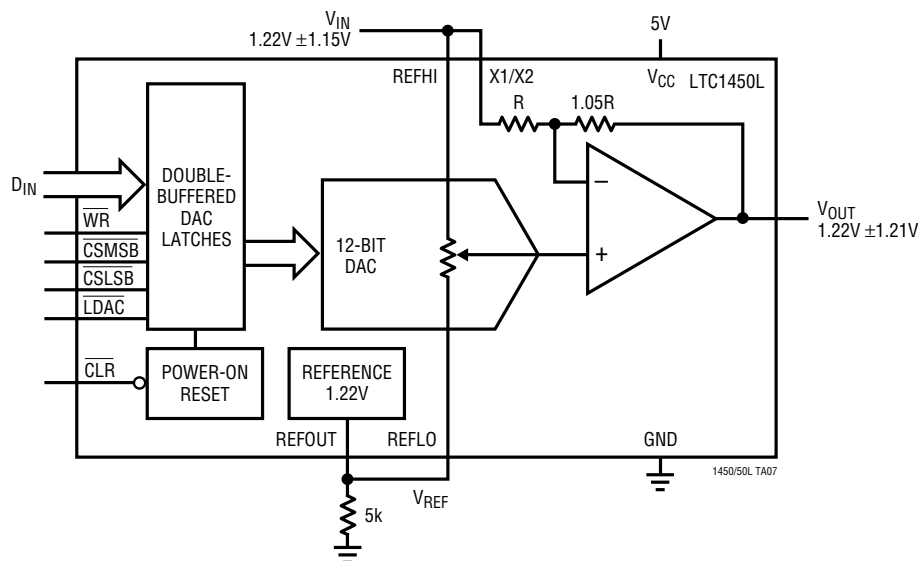

**PACKAGE DESCRIPTION**

Dimensions in Inches (millimeters) unless otherwise noted.

**G Package**  
**24-Lead Plastic SSOP (0.209)**  
 (LTC DWG # 05-08-1640)

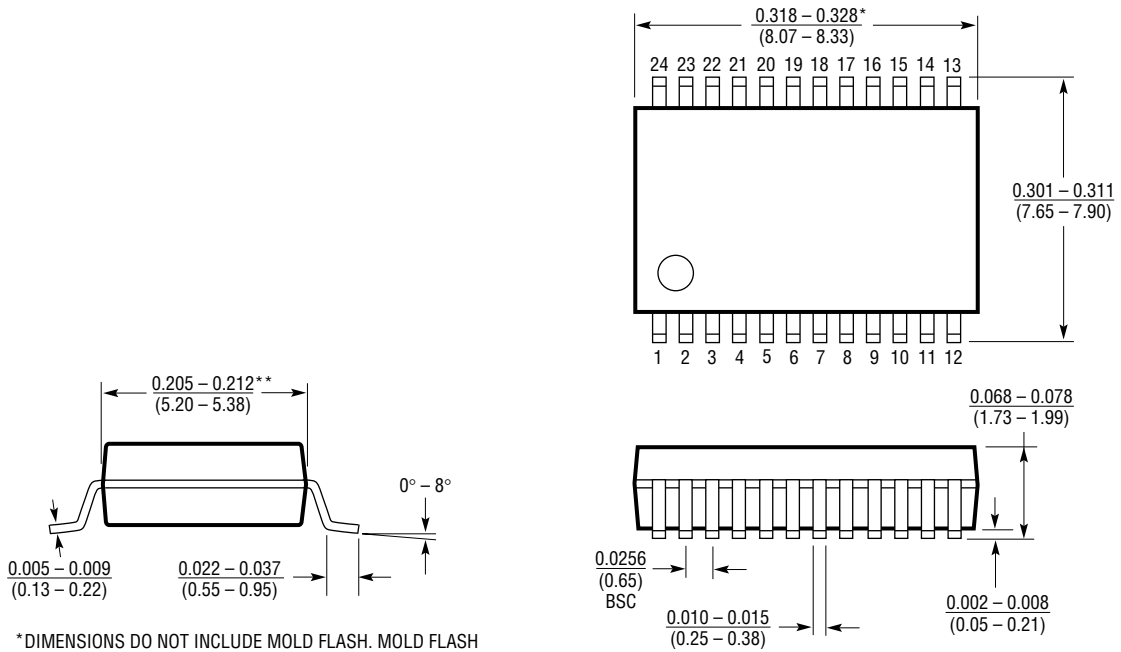

\*DIMENSIONS DO NOT INCLUDE MOLD FLASH. MOLD FLASH SHALL NOT EXCEED 0.006" (0.152mm) PER SIDE  
 \*\*DIMENSIONS DO NOT INCLUDE INTERLEAD FLASH. INTERLEAD FLASH SHALL NOT EXCEED 0.010" (0.254mm) PER SIDE

G24 SSOP 0595

**PACKAGE DESCRIPTION**

Dimensions in inches (millimeters) unless otherwise noted.

**N Package**  
**24-Lead PDIP (Narrow 0.300)**  
 (LTC DWG # 05-08-1510)

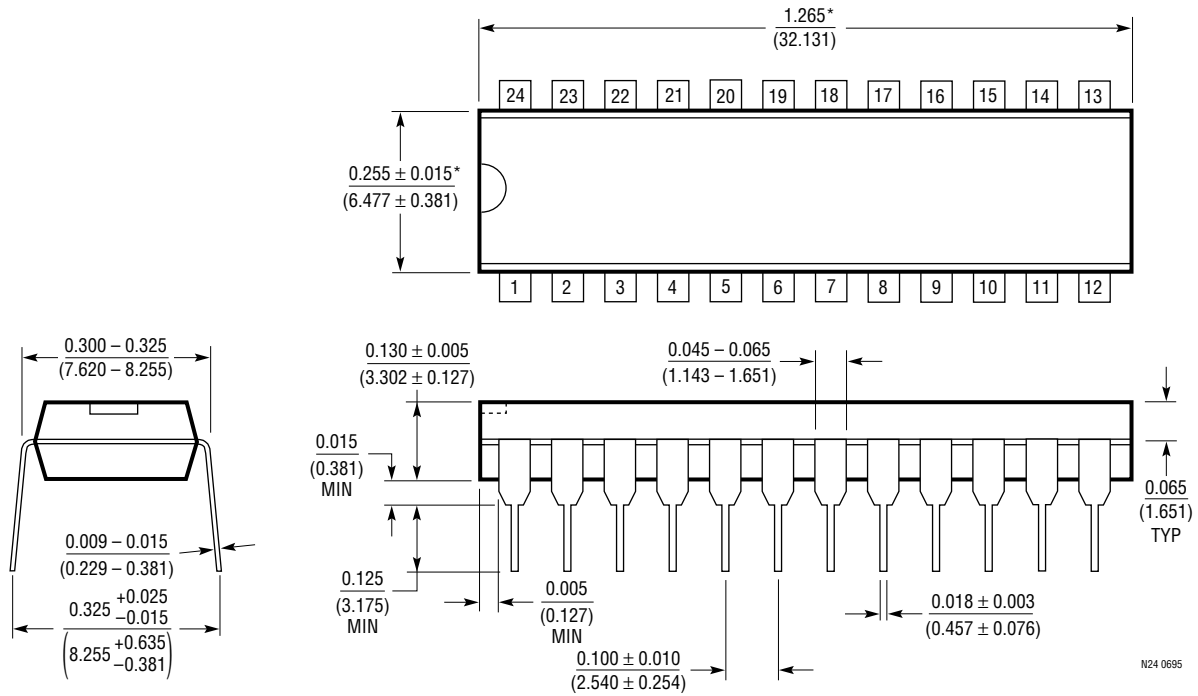

\*THESE DIMENSIONS DO NOT INCLUDE MOLD FLASH OR PROTRUSIONS.  
 MOLD FLASH OR PROTRUSIONS SHALL NOT EXCEED 0.010 INCH (0.254mm)

N24 0695

# LTC1450/LTC1450L

## RELATED PARTS

PART NUMBER	DESCRIPTION	COMMENTS
LTC1257	Complete Serial I/O $V_{OUT}$ 12-Bit DAC	5V to 15V Single Supply in 8-Pin SO and PDIP
LTC1451/LTC1452/LTC1453	Complete Serial I/O $V_{OUT}$ 12-Bit DACs	3V/5V Single Supply, Rail-to-Rail in 8-Pin SO and PDIP
LTC1446/LTC1446L	Dual 12-Bit $V_{OUT}$ DACs in SO-8 Package	LTC1446: $V_{CC} = 4.5V$ TO $5.5V$ , $V_{OUT} = 0V$ TO $4.095V$ LTC1446L: $V_{CC} = 2.7V$ TO $5.5V$ , $V_{OUT} = 0V$ TO $2.5V$
LTC1454/LTC1454L	Dual 12-Bit $V_{OUT}$ DACs in a 16-Pin SO Package with Added Functionality	LTC1454: $V_{CC} = 4.5V$ TO $5.5V$ , $V_{OUT} = 0V$ TO $4.095V$ LTC1454L: $V_{CC} = 2.7V$ TO $5.5V$ , $V_{OUT} = 0V$ TO $2.5V$
LTC1458/LTC1458L	Quad 12-Bit $V_{OUT}$ DACs in 28-Lead SW and SSOP Packages	LTC1458: $V_{CC} = 4.5V$ TO $5.5V$ , $V_{OUT} = 0V$ TO $4.095V$ LTC1458L: $V_{CC} = 2.7V$ TO $5.5V$ , $V_{OUT} = 0V$ TO $2.5V$
LTC7541A	Parallel I/O Multiplying 12-Bit DAC	12-Bit Wide Input
LTC7543/LTC8143	Serial Multiplying 12-Bit DACs	Daisy-Chainable, Flexible Analog and Digital Interface
LTC7545A	Parallel Latched Input Multiplying 12-Bit DAC	12-Bit Wide Latched Input
LTC8043	Serial Multiplying 12-Bit DAC	8-Pin SO and PDIP

## Looking for pricing, stock, or lifecycle information?

Click below to explore more details on WIN SOURCE:

 [View LTC1450IG#PBF on WIN SOURCE](#)

 [Linear Technology](#) Information

## Optimize Your Supply Chain with WIN SOURCE Solutions

-  Global Sourcing Solution
-  Obsolete Management
-  Cost Control Management
-  Shortage Management
-  Alternative Solution
-  Excess Inventory Management