



**THE DATASHEET OF
LTC1418AIG#PBF**



FEATURES

- Single Supply 5V or $\pm 5V$ Operation
- Sample Rate: 200ksps
- $\pm 1.25\text{LSB}$ INL and $\pm 1\text{LSB}$ DNL Max
- Power Dissipation: 15mW (Typ)
- Parallel or Serial Data Output
- No Missing Codes Over Temperature
- Power Shutdown: Nap and Sleep
- External or Internal Reference
- Differential High Impedance Analog Input
- Input Range: 0V to 4.096V or $\pm 2.048V$
- 81.5dB S/(N + D) and -94dB THD at Nyquist
- 28-Lead SSOP Package

APPLICATIONS

- Remote Data Acquisition
- Battery Operated Systems
- Digital Signal Processing
- Isolated Data Acquisition Systems
- Audio and Telecom Processing
- Medical Instrumentation

DESCRIPTION

The LTC[®]1418 is a low power, 200ksps, 14-bit A/D converter. Data output is selectable for 14-bit parallel or serial format. This versatile device can operate from a single 5V or $\pm 5V$ supply. An onboard high performance sample-and-hold, a precision reference and internal timing minimize external circuitry requirements. The low 15mW power dissipation is made even more attractive with two user selectable power shutdown modes.

The LTC1418 converts 0V to 4.096V unipolar inputs from a single 5V supply and $\pm 2.048V$ bipolar inputs from $\pm 5V$ supplies. DC specs include $\pm 1.25\text{LSB}$ INL, $\pm 1\text{LSB}$ DNL and no missing codes over temperature. Outstanding AC performance includes 82dB S/(N + D) and 94dB THD at the Nyquist input frequency of 100kHz.

The flexible output format allows either parallel or serial I/O. The SPI/MICROWIRE compatible serial I/O port can operate as either master or slave and can support clock frequencies from DC to 10MHz. A separate convert start input and a data ready signal ($\overline{\text{BUSY}}$) allow easy control of conversion start and data transfer.

LT, LT, LTC, LTM, Linear Technology and the Linear logo are registered trademarks of Linear Technology Corporation. All other trademarks are the property of their respective owners.

TYPICAL APPLICATION

Low Power, 200kHz, 14-Bit Sampling A/D Converter

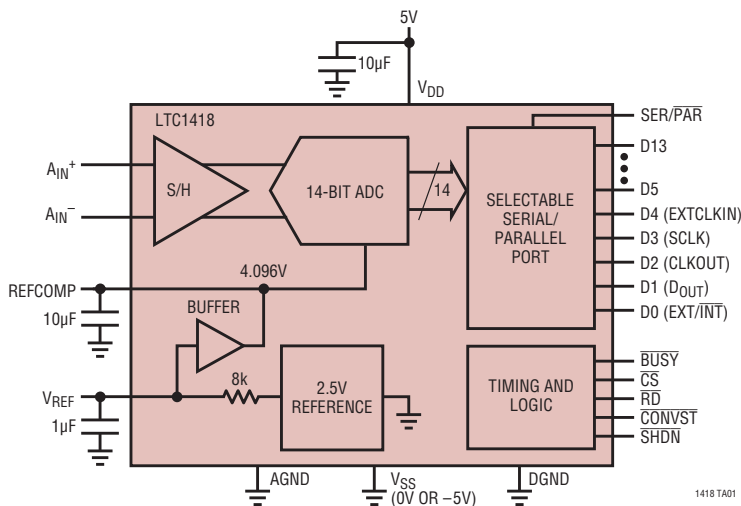

Typical INL Curve

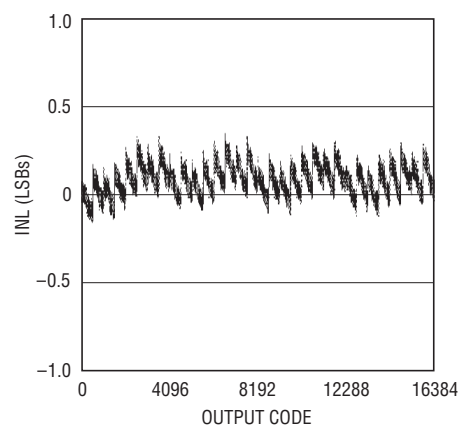

LTC1418

ABSOLUTE MAXIMUM RATINGS

(Note 1, 2)

Supply Voltage (V_{DD})	6V
Negative Supply Voltage (V_{SS})	
Bipolar Operation Only	-6V to GND
Total Supply Voltage (V_{DD} to V_{SS})	
Bipolar Operation Only	12V
Analog Input Voltage (Note 3)	
Unipolar Operation	-0.3V to ($V_{DD} + 0.3V$)
Bipolar Operation	($V_{SS} - 0.3V$) to ($V_{DD} + 0.3V$)
Digital Input Voltage (Note 4)	
Unipolar Operation	-0.3V to 10V
Bipolar Operation	($V_{SS} - 0.3V$) to 10V
Digital Output Voltage	
Unipolar Operation	-0.3V to ($V_{DD} + 0.3V$)
Bipolar Operation	($V_{SS} - 0.3V$) to ($V_{DD} + 0.3V$)
Power Dissipation	500mW
Operation Temperature Range	
LTC1418C	0°C to 70°C
LTC1418I	-40°C to 85°C
Storage Temperature Range	-65°C to 150°C
Lead Temperature (Soldering, 10 sec)	300°C

PACKAGE/ORDER INFORMATION

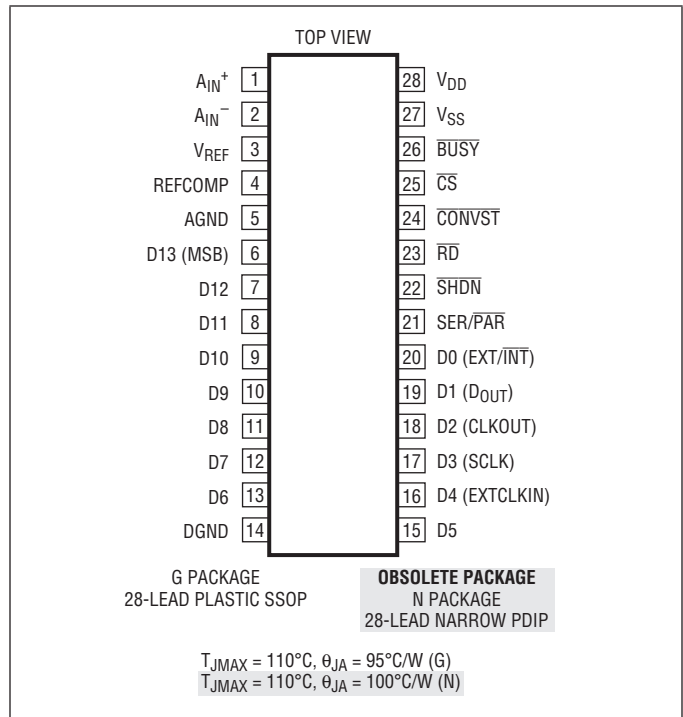

ORDER INFORMATION

LEAD FREE FINISH	TAPE AND REEL	PART MARKING	PACKAGE DESCRIPTION	TEMPERATURE RANGE
LTC1418ACG#PBF	LTC1418ACG#TRPBF	1418ACG	28-Lead Plastic SSOP	0°C to 70°C
LTC1418CG#PBF	LTC1418CG#TRPBF	1418CG	28-Lead Plastic SSOP	0°C to 70°C
LTC1418AIG#PBF	LTC1418AIG#TRPBF	1418AIG	28-Lead Plastic SSOP	-40°C to 85°C
LTC1418IG#PBF	LTC1418IG#TRPBF	1418IG	28-Lead Plastic SSOP	-40°C to 85°C
OBSOLETE PACKAGE				
LTC1418ACN#PBF	LTC1418ACN#TRPBF	1418ACN	28-Lead PDIP	0°C to 70°C
LTC1418CN#PBF	LTC1418CN#TRPBF	1418CN	28-Lead PDIP	0°C to 70°C
LTC1418AIN#PBF	LTC1418AIN#TRPBF	1418AIN	28-Lead PDIP	-40°C to 85°C
LTC1418IN#PBF	LTC1418IN#TRPBF	1418IN	28-Lead PDIP	-40°C to 85°C

Consult LTC Marketing for parts specified with wider operating temperature ranges.

Consult LTC Marketing for information on nonstandard lead based finish parts.

For more information on lead free part marking, go to: <http://www.linear.com/leadfree/>

For more information on tape and reel specifications, go to: <http://www.linear.com/tapeandree/>

CONVERTER CHARACTERISTICS

The ● denotes the specifications which apply over the full operating temperature range, otherwise specifications are at $T_A = 25^\circ\text{C}$. (Notes 5, 6)

PARAMETER	CONDITIONS	LTC1418			LTC1418A			UNITS
		MIN	TYP	MAX	MIN	TYP	MAX	
Resolution (No Missing Codes)		●	13		14		Bits	
Integral Linearity Error	(Note 7)	●	±0.8	±2	±0.5	±1.25	LSB	
Differential Linearity Error		●	±0.7	±1.5	±0.35	±1	LSB	
Offset Error	(Note 8)	●	±5	±20	±2	±10	LSB	
Full-Scale Error	Internal Reference		±10	±60	±20	±60	LSB	
	External Reference = 2.5V		±5	±30	±5	±15	LSB	
Full-Scale Tempco	$I_{OUT(REF)} = 0$, Internal Reference, Commercial	●	±15		±10	±45	ppm/°C	
	$I_{OUT(REF)} = 0$, Internal Reference, Industrial				±20		ppm/°C	
	$I_{OUT(REF)} = 0$, External Reference		±5		±1		ppm/°C	

ANALOG INPUT

The ● denotes the specifications which apply over the full operating temperature range, otherwise specifications are at $T_A = 25^\circ\text{C}$. (Note 5)

SYMBOL	PARAMETER	CONDITIONS	MIN	TYP	MAX	UNITS
V_{IN}	Analog Input Range (Note 9)	$4.75\text{V} \leq V_{DD} \leq 5.25\text{V}$ (Unipolar)	●	0 to 4.096		V
		$4.75\text{V} \leq V_{DD} \leq 5.25\text{V}$, $-5.25\text{V} \leq V_{SS} \leq -4.75\text{V}$ (Bipolar)	●	±2.048		V
I_{IN}	Analog Input Leakage Current	$\overline{CS} = \text{High}$	●		±1	μA
C_{IN}	Analog Input Capacitance	Between Conversions (Sample Mode)		25		pF
		During Conversions (Hold Mode)		5		pF
t_{ACQ}	Sample-and-Hold Acquisition Time	Commercial	●	300	1000	ns
		Industrial	●	300	1000	ns

DYNAMIC ACCURACY

The ● denotes the specifications which apply over the full operating temperature range, otherwise specifications are at $T_A = 25^\circ\text{C}$. (Note 5)

SYMBOL	PARAMETER	CONDITIONS	MIN	TYP	MAX	UNITS
S/(N + D)	Signal-to-Noise Plus Distortion Ratio	97.5kHz Input Signal	●	79	81.5	dB
THD	Total Harmonic Distortion	100kHz Input Signal, First 5 Harmonics	●	-94	-86	dB
SFDR	Spurious Free Dynamic Range	100kHz Input Signal	●	86	95	dB
IMD	Intermodulation Distortion	$f_{IN1} = 97.7\text{kHz}$, $f_{IN2} = 104.2\text{kHz}$		-90		dB
	Full Power Bandwidth			5		MHz
	Full Linear Bandwidth	$S/(N + D) \geq 77\text{dB}$			0.5	MHz

INTERNAL REFERENCE CHARACTERISTICS

The ● denotes the specifications which apply over the full operating temperature range, otherwise specifications are at $T_A = 25^\circ\text{C}$. (Note 5)

PARAMETER	CONDITIONS	MIN	TYP	MAX	UNITS
V_{REF} Output Voltage	$I_{OUT} = 0$	2.480	2.500	2.520	V
V_{REF} Output Tempco	$I_{OUT} = 0$, Commercial $I_{OUT} = 0$, Industrial	●	±10 ±20	±45	ppm/ $^\circ\text{C}$ ppm/ $^\circ\text{C}$
V_{REF} Line Regulation	$4.75\text{V} \leq V_{DD} \leq 5.25\text{V}$ $-5.25\text{V} \leq V_{SS} \leq -4.75\text{V}$		0.05 0.05		LSB/V LSB/V
V_{REF} Output Resistance	$0.1\text{mA} \leq I_{OUT} \leq 0.1\text{mA}$		8		k Ω

DIGITAL INPUTS AND OUTPUTS

The ● denotes the specifications which apply over the full operating temperature range, otherwise specifications are at $T_A = 25^\circ\text{C}$. (Note 5)

SYMBOL	PARAMETER	CONDITIONS	MIN	TYP	MAX	UNITS
V_{IH}	High Level Input Voltage	$V_{DD} = 5.25\text{V}$	●	2.4		V
V_{IL}	Low Level Input Voltage	$V_{DD} = 4.75\text{V}$	●		0.8	V
I_{IN}	Digital Input Current	$V_{IN} = 0\text{V}$ to V_{DD}	●		±10	μA
C_{IN}	Digital Input Capacitance			1.4		pF
V_{OH}	High Level Output Voltage	$V_{DD} = 4.75\text{V}$, $I_O = -10\mu\text{A}$ $V_{DD} = 4.75\text{V}$, $I_O = -200\mu\text{A}$	●	4.0	4.74	V V
V_{OL}	Low Level Output Voltage	$V_{DD} = 4.75\text{V}$, $I_O = 160\mu\text{A}$ $V_{DD} = 4.75\text{V}$, $I_O = 1.6\text{mA}$	●		0.05 0.10	V V
I_{OZ}	Hi-Z Output Leakage D13 to D0	$V_{OUT} = 0\text{V}$ to V_{DD} , \overline{CS} High	●		±10	μA
C_{OZ}	Hi-Z Output Capacitance D13 to D0	\overline{CS} High (Note 9)	●		15	pF
I_{SOURCE}	Output Source Current	$V_{OUT} = 0\text{V}$		-10		mA
I_{SINK}	Output Sink Current	$V_{OUT} = V_{DD}$		10		mA

POWER REQUIREMENTS

The ● denotes the specifications which apply over the full operating temperature range, otherwise specifications are at $T_A = 25^\circ\text{C}$. (Note 5)

SYMBOL	PARAMETER	CONDITIONS	MIN	TYP	MAX	UNITS
V_{DD}	Positive Supply Voltage (Notes 10, 11)		4.75		5.25	V
V_{SS}	Negative Supply Voltage (Note 10)	Bipolar Only ($V_{SS} = 0\text{V}$ for Unipolar)	-4.75		-5.25	V
I_{DD}	Positive Supply Current	Unipolar, \overline{RD} High (Note 5) Bipolar, \overline{RD} High (Note 5) Nap Mode Sleep Mode $\overline{SHDN} = 0\text{V}$, $\overline{CS} = 0\text{V}$ (Note 12) $\overline{SHDN} = 0\text{V}$, $\overline{CS} = 5\text{V}$ (Note 12)	● ●	3.0 3.9 570 2	4.3 4.5	mA μA μA
I_{SS}	Negative Supply Current	Bipolar, \overline{RD} High (Note 5) Nap Mode Sleep Mode $\overline{SHDN} = 0\text{V}$, $\overline{CS} = 0\text{V}$ (Note 12) $\overline{SHDN} = 0\text{V}$, $\overline{CS} = 5\text{V}$ (Note 12)	●	1.4 0.1 0.1	1.8	mA μA μA
P_{DIS}	Power Dissipation	Unipolar Bipolar	● ●	15.0 26.5	21.5 31.5	mW mW

TIMING CHARACTERISTICS

The ● denotes the specifications which apply over the full operating temperature range, otherwise specifications are at $T_A = 25^\circ\text{C}$. (Note 5)

SYMBOL	PARAMETER	CONDITIONS	MIN	TYP	MAX	UNITS
$f_{\text{SAMPLE(MAX)}}$	Maximum Sampling Frequency		●	200		kHz
t_{CONV}	Conversion Time		●	3.4	4	μs
t_{ACQ}	Acquisition Time		●	0.3	1	μs
$t_{\text{ACQ}} + t_{\text{CONV}}$	Acquisition Plus Conversion Time		●	3.7	5	μs
t_1	$\overline{\text{CS}}$ to $\overline{\text{RD}}$ Setup Time	(Notes 9, 10)	●	0		ns
t_2	$\overline{\text{CS}}$ ↓ to $\overline{\text{CONVST}}$ ↓ Setup Time	(Notes 9, 10)	●	40		ns
t_3	$\overline{\text{CS}}$ ↓ to $\overline{\text{SHDN}}$ ↓ Setup Time to Ensure Nap Mode	(Notes 9, 10)	●	40		ns
t_4	$\overline{\text{SHDN}}$ ↑ to $\overline{\text{CONVST}}$ ↓ Wake-Up Time from Nap Mode	(Note 10)		500		ns
t_5	$\overline{\text{CONVST}}$ Low Time	(Notes 10, 11)	●	40		ns
t_6	$\overline{\text{CONVST}}$ to $\overline{\text{BUSY}}$ Delay	$C_L = 25\text{pF}$	●	35	70	ns
t_7	Data Ready Before $\overline{\text{BUSY}}$ ↑		●	20	35	ns
t_8	Delay Between Conversions	(Note 10)	●	500		ns
t_9	Wait Time $\overline{\text{RD}}$ ↓ After $\overline{\text{BUSY}}$ ↑		●	-5		ns
t_{10}	Data Access Time After $\overline{\text{RD}}$ ↓	$C_L = 25\text{pF}$	●	15	30	ns
					40	ns
		$C_L = 100\text{pF}$	●	20	40	ns
					55	ns
t_{11}	Bus Relinquish Time			8	20	ns
		Commercial	●		25	ns
		Industrial	●		30	ns
t_{12}	$\overline{\text{RD}}$ Low Time		●	t_{10}		ns
t_{13}	$\overline{\text{CONVST}}$ High Time			40		ns
t_{14}	Delay Time, $\overline{\text{SCLK}}$ ↓ to D_{OUT} Valid	$C_L = 25\text{pF}$ (Note 9)	●	35	70	ns
t_{15}	Time from Previous Data Remain Valid After $\overline{\text{SCLK}}$ ↓	$C_L = 25\text{pF}$ (Note 9)	●	15	25	ns
f_{SCLK}	Shift Clock Frequency	(Notes 9, 10)		0	12.5	MHz
f_{EXTCLKIN}	External Conversion Clock Frequency	(Notes 9, 10)		0.03	4.5	MHz
$t_{\text{dEXTCLKIN}}$	Delay Time, $\overline{\text{CONVST}}$ ↓ to External Conversion Clock Input	(Notes 9, 10)			533	μs
$t_{\text{H SCLK}}$	SCLK High Time	(Notes 9, 10)		10		ns
$t_{\text{L SCLK}}$	SCLK Low Time	(Notes 9, 10)		20		ns
$t_{\text{H EXTCLKIN}}$	EXTCLKIN High Time	(Notes 9, 10)		250		ns
$t_{\text{L EXTCLKIN}}$	EXTCLKIN Low Time	(Notes 9, 10)		250		ns

Note 1: Stresses beyond those listed under Absolute Maximum Ratings may cause permanent damage to the device. Exposure to any Absolute Maximum Rating condition for extended periods may affect device reliability and lifetime.

Note 2: All voltage values are with respect to ground with DGND and AGND wired together (unless otherwise noted).

Note 3: When these pin voltages are taken below V_{SS} or above V_{DD} , they will be clamped by internal diodes. This product can handle input currents greater than 100mA below V_{SS} or above V_{CC} without latchup.

Note 4: When these pin voltages are taken below V_{SS} they will be clamped by internal diodes. This product can handle input currents greater than 100mA below V_{SS} without latchup. These pins are not clamped to V_{DD} .

Note 5: $V_{\text{DD}} = 5\text{V}$, $V_{\text{SS}} = 0\text{V}$ or -5V , $f_{\text{SAMPLE}} = 200\text{kHz}$, $t_r = t_f = 5\text{ns}$ unless otherwise specified.

Note 6: Linearity, offset and full-scale specifications apply for a single-ended input with A_{IN^-} grounded.

Note 7: Integral nonlinearity is defined as the deviation of a code from a straight line passing through the actual endpoints of the transfer curve. The deviation is measured from the center of the quantization band.

Note 8: Bipolar offset is the offset voltage measured from -0.5LSB when the output code flickers between 0000 0000 0000 00 and 1111 1111 1111 11.

Note 9: Guaranteed by design, not subject to test.

Note 10: Recommended operating conditions.

Note 11: The falling edge of $\overline{\text{CONVST}}$ starts a conversion. If $\overline{\text{CONVST}}$ returns high at a critical point during the conversion, it can create small errors. For best performance ensure that $\overline{\text{CONVST}}$ returns high either within $2.1\mu\text{s}$ after the conversion starts or after $\overline{\text{BUSY}}$ rises.

Note 12: Pins 16 (D4/EXTCLKIN), 17 (D3/SCLK) and 20 (DO/EXT/INT) at 0V or 5V. See Power Shutdown.

TYPICAL PERFORMANCE CHARACTERISTICS

Typical INL Curve

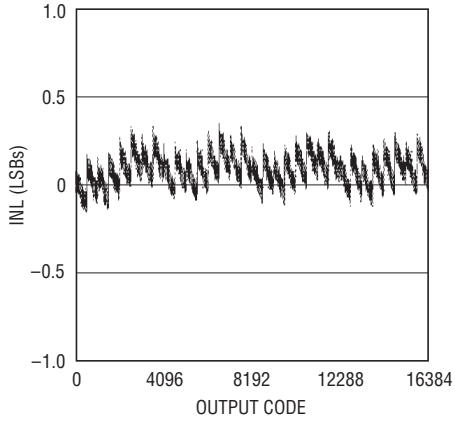

1418 G01

Differential Nonlinearity vs Output Code

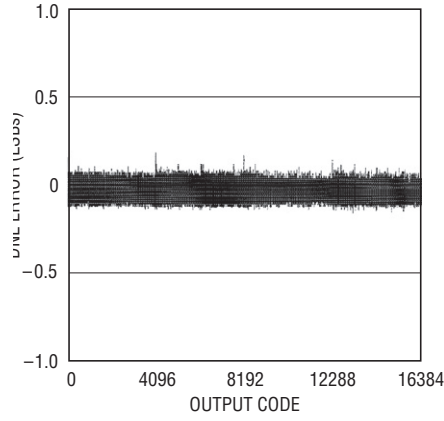

1418 G02

S/(N + D) vs Input Frequency and Amplitude

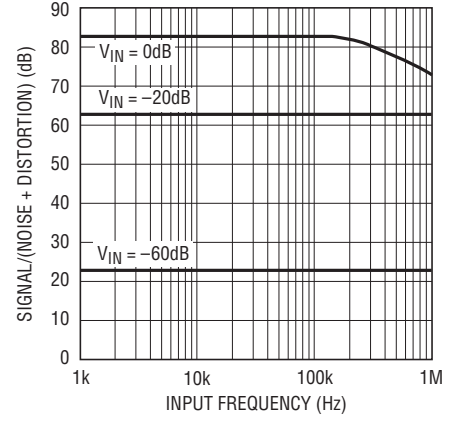

1418 G03

Signal-to-Noise Ratio vs Input Frequency

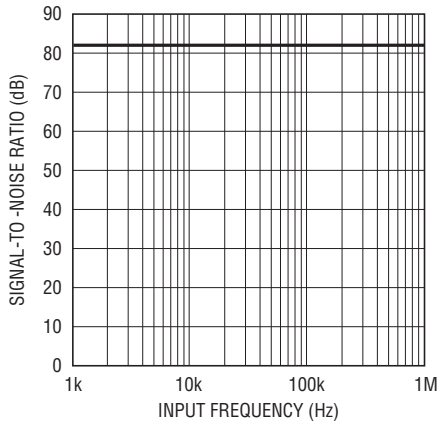

1418 G04

Distortion vs Input Frequency

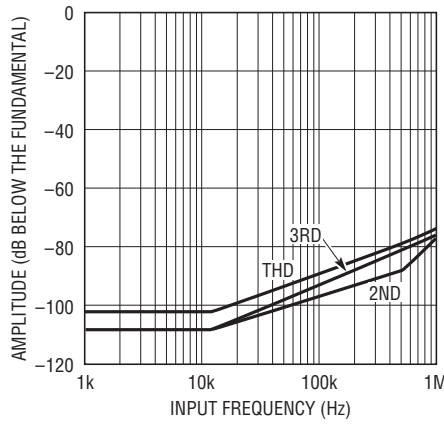

1418 G05

Spurious-Free Dynamic Range vs Input Frequency

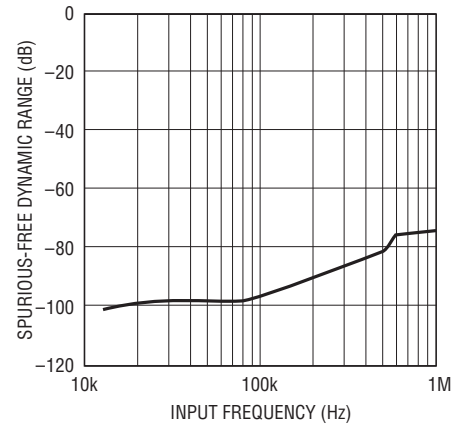

1418 G06

Nonaveraged, 4096 Point FFT, Input Frequency = 10kHz

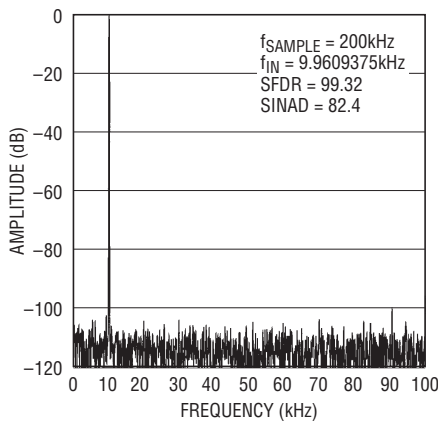

1418 G07

Nonaveraged, 4096 Point FFT, Input Frequency = 100kHz

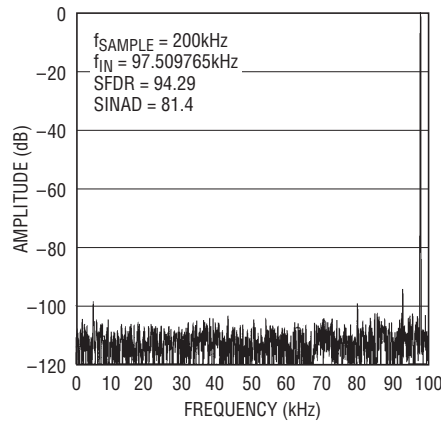

1418 G08

Intermodulation Distortion Plot

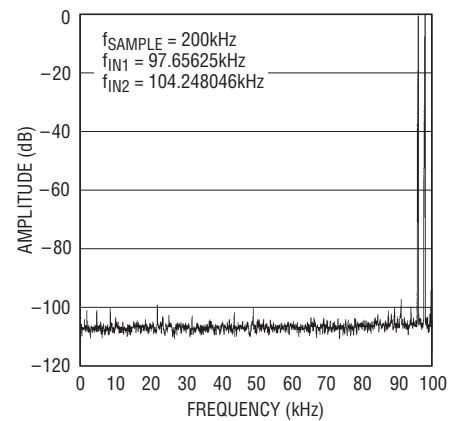

1418 G09

TYPICAL PERFORMANCE CHARACTERISTICS

Power Supply Feedthrough vs Ripple Frequency

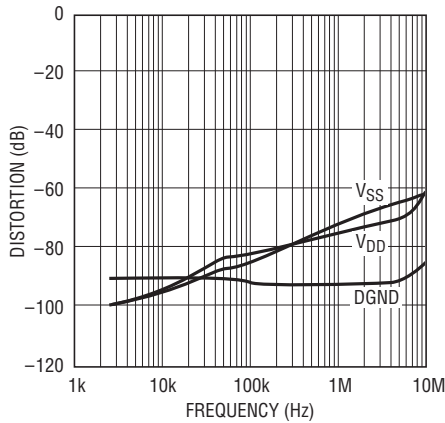

1418 G10

Input Common Mode Rejection vs Input Frequency

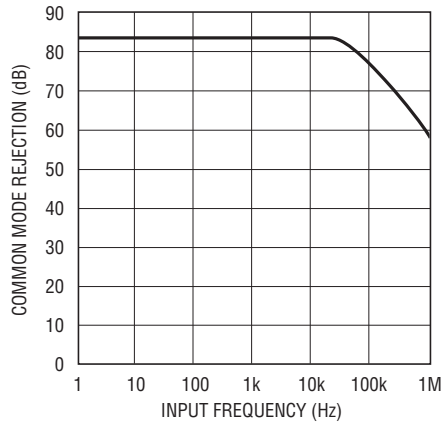

1418 G11

Input Offset Voltage Shift vs Source Resistance

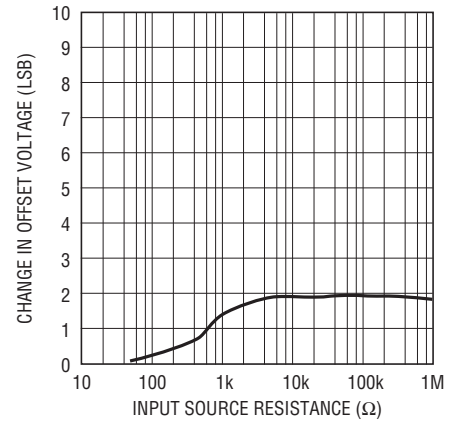

1418 G12

V_{DD} Supply Current vs Temperature (Unipolar Mode)

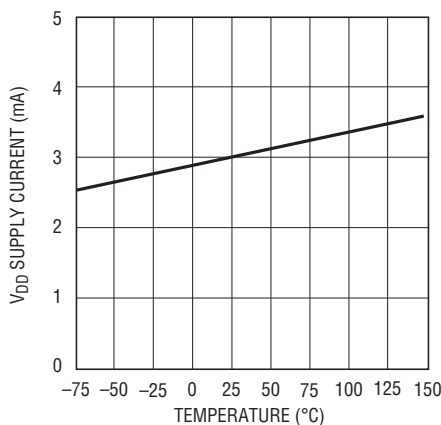

1418 G13

V_{DD} Supply Current vs Temperature (Bipolar Mode)

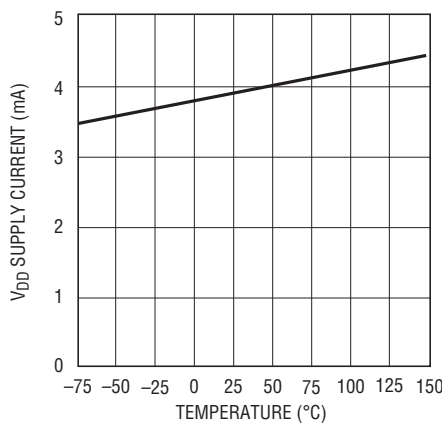

1418 G14

V_{SS} Supply Current vs Temperature (Bipolar Mode)

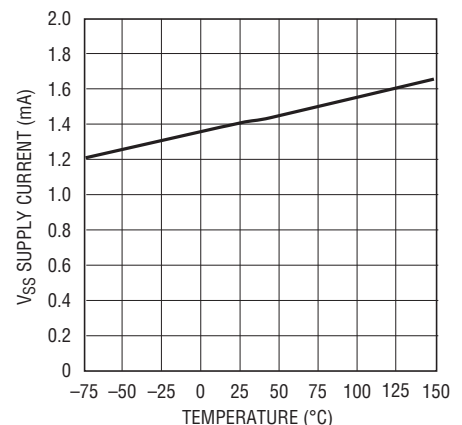

1418 G15

V_{DD} Supply Current vs Sampling Frequency (Unipolar Mode)

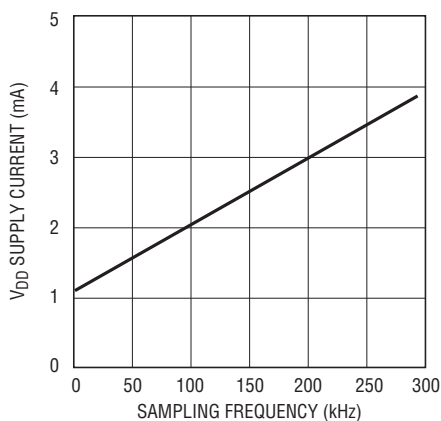

1418 G16

V_{DD} Supply Current vs Sampling Frequency (Bipolar Mode)

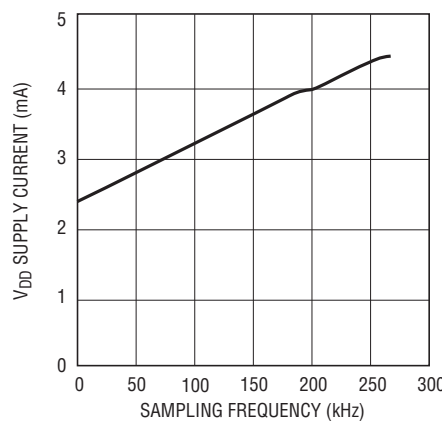

1418 G17

V_{SS} Supply Current vs Sampling Frequency (Bipolar Mode)

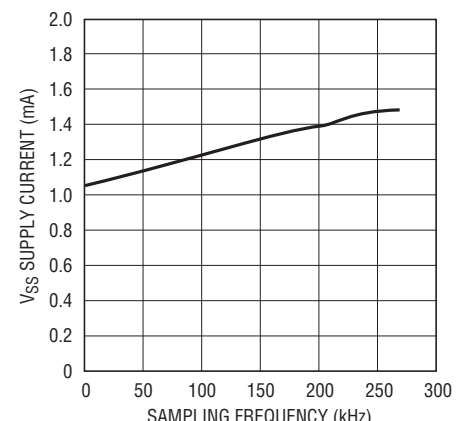

1418 G18

PIN FUNCTIONS

A_{IN}⁺ (Pin 1): Positive Analog Input.

A_{IN}⁻ (Pin 2): Negative Analog Input.

V_{REF} (Pin 3): 2.50V Reference Output. Bypass to AGND with 1μF.

REFCOMP (Pin 4): 4.096V Reference Bypass Pin. Bypass to AGND with 10μF tantalum in parallel with 0.1μF ceramic.

AGND (Pin 5): Analog Ground.

D13 to D6 (Pins 6 to 13): Three-State Data Outputs (Parallel). D13 is the most significant bit.

DGND (Pin 14): Digital Ground for Internal Logic. Tie to AGND.

D5 (Pin 15): Three-State Data Output (Parallel).

D4 (EXTCLKIN) (Pin 16): Three-State Data Output (Parallel). Conversion clock input (serial) when Pin 20 (EXT/INT) is tied high.

D3 (SCLK) (Pin 17): Three-State Data Output (Parallel). Data clock input (serial).

D2 (CLKOUT) (Pin 18): Three-State Data Output (Parallel). Conversion clock output (serial).

D1 (D_{OUT}) (Pin 19): Three-State Data Output (Parallel). Serial data output (serial).

D0 (EXT/INT) (Pin 20): Three-State Data Output (Parallel). Conversion clock selector (serial). An input low enables the internal conversion clock. An input high indicates an external conversion clock will be assigned to Pin 16 (EXTCLKIN).

SER/PAR (Pin 21): Data Output Mode.

SHDN (Pin 22): Power Shutdown Input. Low selects shutdown. Shutdown mode selected by \overline{CS} . $\overline{CS} = 0$ for nap mode and $\overline{CS} = 1$ for sleep mode.

RD (Pin 23): Read Input. This enables the output drivers when \overline{CS} is low.

CONVST (Pin 24): Conversion Start Signal. This active low signal starts a conversion on its falling edge.

CS (Pin 25): Chip Select. This input must be low for the ADC to recognize the \overline{CONVST} and \overline{RD} inputs. \overline{CS} also sets the shutdown mode when SHDN goes low. \overline{CS} and \overline{SHDN} low select the quick wake-up nap mode. \overline{CS} high and \overline{SHDN} low select sleep mode.

BUSY (Pin 26): The \overline{BUSY} Output Shows the Converter Status. It is low when a conversion is in progress.

V_{SS} (Pin 27): Negative Supply, -5V for Bipolar Operation. Bypass to AGND with 10μF tantalum in parallel with 0.1μF ceramic. Analog ground for unipolar operation.

V_{DD} (Pin 28): 5V Positive Supply. Bypass to AGND with 10μF tantalum in parallel with 0.1μF ceramic.

TEST CIRCUITS

Load Circuits for Access Timing

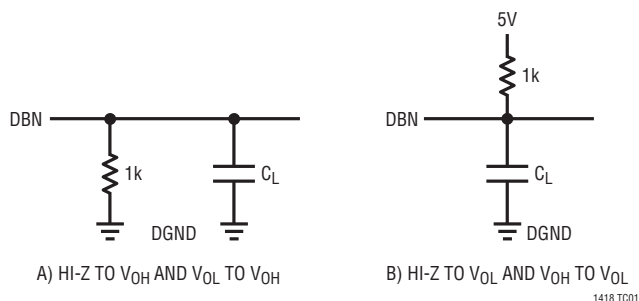

Load Circuits for Output Float Delay

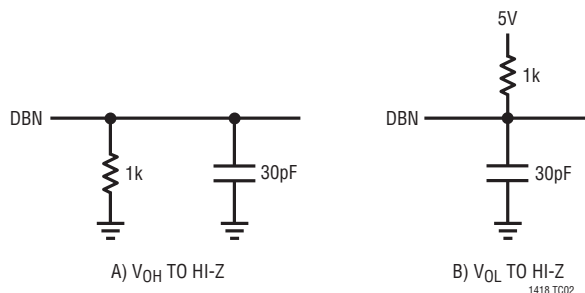

BLOCK DIAGRAM

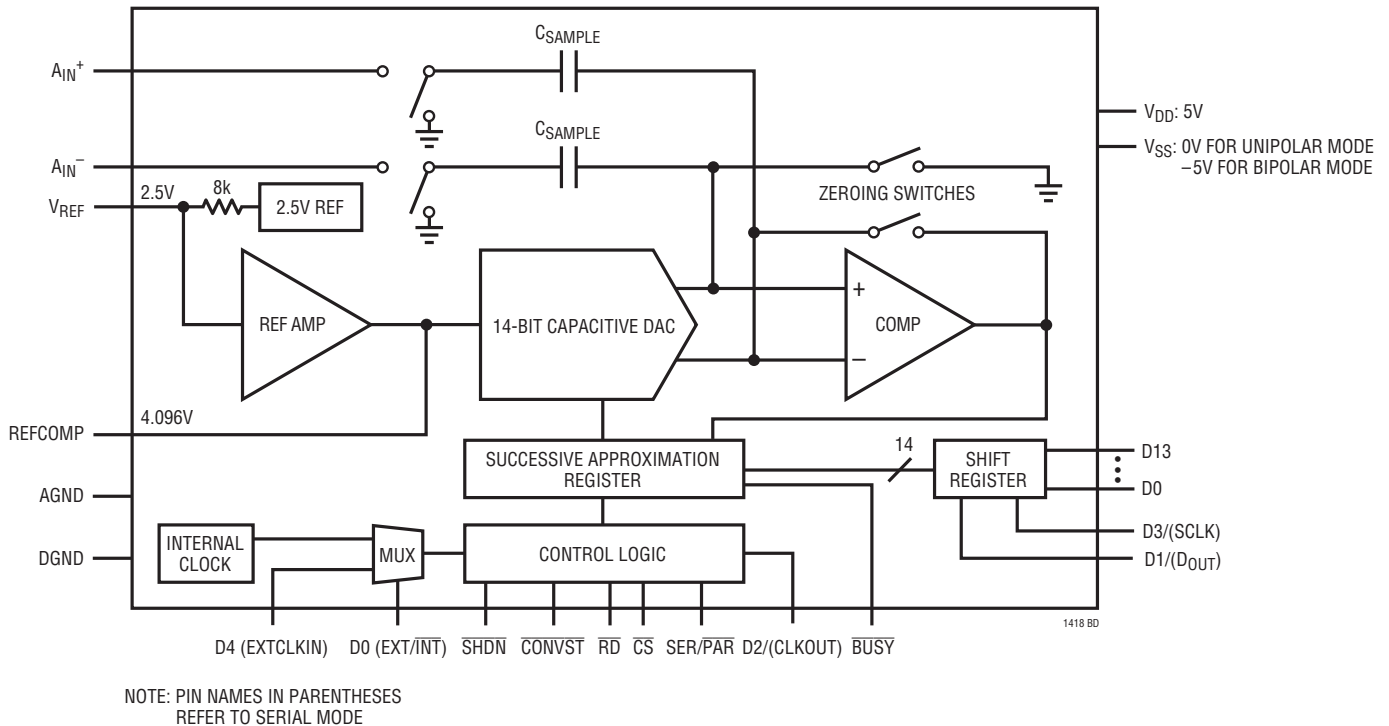

APPLICATIONS INFORMATION

CONVERSION DETAILS

The LTC1418 uses a successive approximation algorithm and an internal sample-and-hold circuit to convert an analog signal to a 14-bit parallel or serial output. The ADC is complete with a precision reference and an internal clock. The control logic provides easy interface to microprocessors and DSPs (please refer to Digital Interface section for the data format).

Conversion start is controlled by the \overline{CS} and \overline{CONVST} inputs. At the start of the conversion the successive approximation register (SAR) is reset. Once a conversion cycle has begun it cannot be restarted.

During the conversion, the internal differential 14-bit capacitive DAC output is sequenced by the SAR from the most significant bit (MSB) to the least significant bit (LSB).

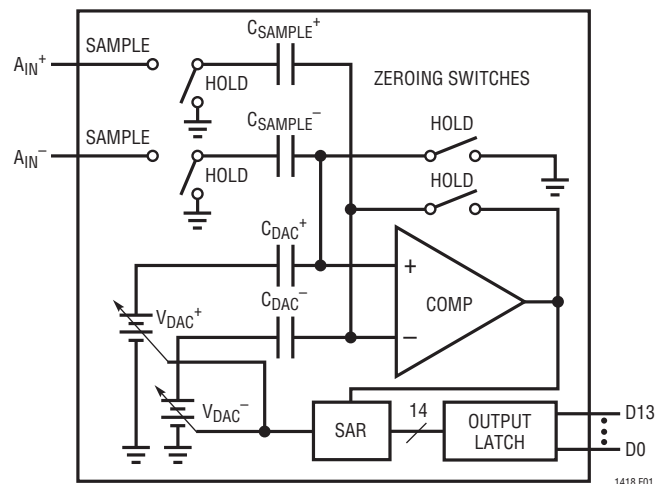

Figure 1. Simplified Block Diagram

APPLICATIONS INFORMATION

Referring to Figure 1, the A_{IN}^+ and A_{IN}^- inputs are connected to the sample-and-hold capacitors (C_{SAMPLE}) during the acquire phase and the comparator offset is nulled by the zeroing switches. In this acquire phase, a minimum delay of $1\mu s$ will provide enough time for the sample-and-hold capacitors to acquire the analog signal. During the convert phase, the comparator zeroing switches open, putting the comparator into compare mode. The input switches the C_{SAMPLE} capacitors to ground, transferring the differential analog input charge onto the summing junction. This input charge is successively compared with the binary weighted charges supplied by the differential capacitive DAC. Bit decisions are made by the high speed comparator. At the end of a conversion, the differential DAC output balances the A_{IN}^+ and A_{IN}^- input charges. The SAR contents (a 14-bit data word) which represent the difference of A_{IN}^+ and A_{IN}^- are loaded into the 14-bit output latches.

DYNAMIC PERFORMANCE

The LTC1418 has excellent high speed sampling capability. FFT (Fast Fourier Transform) test techniques are used to test the ADC's frequency response, distortion and noise at the rated throughput. By applying a low distortion sine wave and analyzing the digital output using an FFT algorithm, the ADC's spectral content can be examined for frequencies outside the fundamental. Figure 2a shows a typical LTC1418 FFT plot.

Signal-to-Noise Ratio

The signal-to-noise plus distortion ratio [$S/(N + D)$] is the ratio between the RMS amplitude of the fundamental input frequency to the RMS amplitude of all other frequency components at the A/D output. The output is band limited to frequencies from above DC and below half the sampling frequency. Figure 2b shows a typical spectral content with a 200kHz sampling rate and a 10kHz input. The dynamic performance is excellent for input frequencies up to and beyond the Nyquist limit of 100kHz.

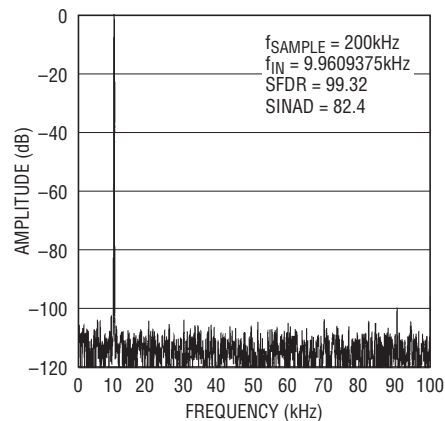

1418 F02a

Figure 2a. LTC1418 Nonaveraged, 4096 Point FFT, Input Frequency = 10kHz

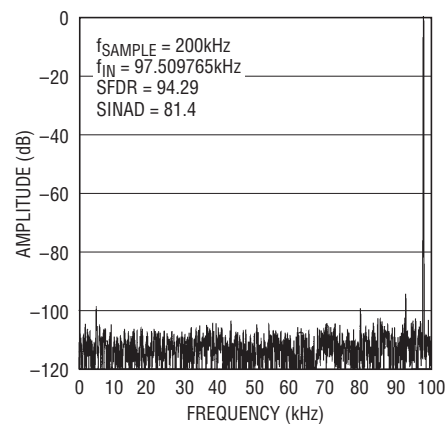

1418 F02b

Figure 2b. LTC1418 Nonaveraged, 4096 Point FFT, Input Frequency = 97.5kHz

Effective Number of Bits

The effective number of bits (ENOBs) is a measurement of the resolution of an ADC and is directly related to the $S/(N + D)$ by the equation:

$$N = [S/(N + D) - 1.76]/6.02$$

where N is the effective number of bits of resolution and $S/(N + D)$ is expressed in dB. At the maximum sampling rate of 200kHz, the LTC1418 maintains near ideal ENOBs up to the Nyquist input frequency of 100kHz (refer to Figure 3).

APPLICATIONS INFORMATION

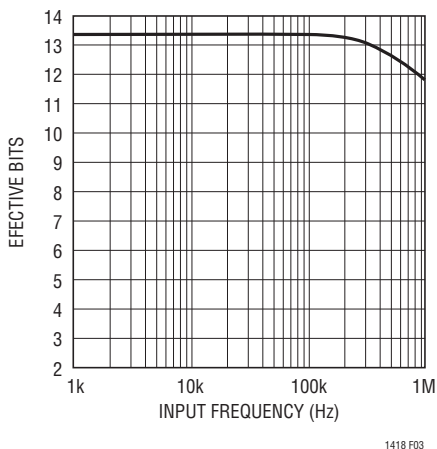

Figure 3. Effective Bits and Signal/(Noise + Distortion) vs Input Frequency

Total Harmonic Distortion

Total harmonic distortion (THD) is the ratio of the RMS sum of all harmonics of the input signal to the fundamental itself. The out-of-band harmonics alias into the frequency band between DC and half the sampling frequency. THD is expressed as:

$$THD = 20\text{Log} \frac{\sqrt{V_2^2 + V_3^2 + V_4^2 + \dots + V_N^2}}{V_1}$$

where V1 is the RMS amplitude of the fundamental frequency and V2 through V_N are the amplitudes of the second through nth harmonics. THD vs Input Frequency is shown in Figure 4. The LTC1418 has good distortion performance up to the Nyquist frequency and beyond.

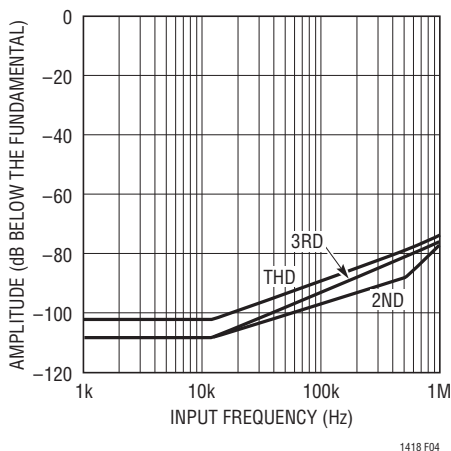

Figure 4. Distortion vs Input Frequency

Intermodulation Distortion

If the ADC input signal consists of more than one spectral component, the ADC transfer function nonlinearity can produce intermodulation distortion (IMD) in addition to THD. IMD is the change in one sinusoidal input caused by the presence of another sinusoidal input at a different frequency.

If two pure sine waves of frequencies f_a and f_b are applied to the ADC input, nonlinearities in the ADC transfer function can create distortion products at the sum and difference frequencies of m f_a ± n f_b, where m and n = 0, 1, 2, 3, etc. For example, the 2nd order IMD terms include (f_a + f_b). If the two input sine waves are equal in magnitude, the value (in decibels) of the 2nd order IMD products can be expressed by the following formula:

$$IMD(f_a + f_b) = 20\text{Log} \frac{\text{Amplitude at } (f_a + f_b)}{\text{Amplitude at } f_a}$$

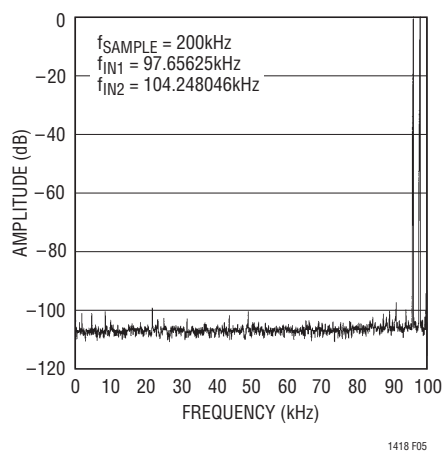

Figure 5. Intermodulation Distortion Plot

Peak Harmonic or Spurious Noise

The peak harmonic or spurious noise is the largest spectral component excluding the input signal and DC. This value is expressed in decibels relative to the RMS value of a full-scale input signal.

APPLICATIONS INFORMATION

Full-Power and Full-Linear Bandwidth

The full-power bandwidth is that input frequency at which the amplitude of the reconstructed fundamental is reduced by 3dB for a full-scale input signal.

The full-linear bandwidth is the input frequency at which the $S/(N + D)$ has dropped to 77dB (12.5 effective bits). The LTC1418 has been designed to optimize input bandwidth, allowing the ADC to undersample input signals with frequencies above the converter's Nyquist Frequency. The noise floor stays very low at high frequencies; $S/(N + D)$ becomes dominated by distortion at frequencies far beyond Nyquist.

DRIVING THE ANALOG INPUT

The differential analog inputs of the LTC1418 are easy to drive. The inputs may be driven differentially or as a single-ended input (i.e., the A_{IN-} input is grounded). The A_{IN+} and A_{IN-} inputs are sampled at the same instant. Any unwanted signal that is common mode to both inputs will be reduced by the common mode rejection of the sample-and-hold circuit. The inputs draw only one small current spike while charging the sample-and-hold capacitors at the end of conversion. During conversion, the analog inputs draw only a small leakage current. If the source impedance of the driving circuit is low then the LTC1418 inputs can be driven directly. As source impedance increases so will acquisition time (see Figure 6). For minimum acquisition time, with high source impedance, a buffer amplifier must be used. The only requirement is that the amplifier driving the analog input(s) must settle after the small current spike before the next conversion starts— $1\mu\text{s}$ for full throughput rate.

Choosing an Input Amplifier

Choosing an input amplifier is easy if a few requirements are taken into consideration. First, choose an amplifier that has a low output impedance ($<100\Omega$) at the closed-loop bandwidth frequency. For example, if an amplifier is used in a gain of 1 and has a closed-loop bandwidth of 10MHz, then the output impedance at 10MHz must be less than 100Ω . The second requirement is that the closed-loop bandwidth must be greater than 5MHz to ensure adequate

small-signal settling for full throughput rate. If slower op amps are used, more settling time can be provided by increasing the time between conversions.

The best choice for an op amp to drive the LTC1418 will depend on the application. Generally, applications fall into two categories: AC applications where dynamic specifications are most critical and time domain applications where DC accuracy and settling time are most critical. The following list is a summary of the op amps that are suitable for driving the LTC1418. More detailed information is available at www.linear.com.

LT[®]1354: 12MHz, 400V/ μs Op Amp. 1.25mA maximum supply current. Good AC and DC specifications. Suitable for dual supply application.

LT1357: 25MHz, 600V/ μs Op Amp. 2.5mA maximum supply current. Good AC and DC specifications. Suitable for dual supply application.

LT1366/LT1367: Dual/Quad Precision Rail-to-Rail Input and Output Op Amps. 375 μA supply current per amplifier. 1.8V to $\pm 15\text{V}$ supplies. Low input offset voltage: 150 μV . Good for low power and single supply applications with sampling rates of 20ksps and under.

LT1498/LT1499: 10MHz, 6V/ μs , Dual/Quad Rail-to-Rail Input and Output Op Amps. 1.7mA supply current per amplifier. 2.2V to $\pm 15\text{V}$ supplies. Good AC performance, input noise voltage = 12nV/ $\sqrt{\text{Hz}}$ (typ).

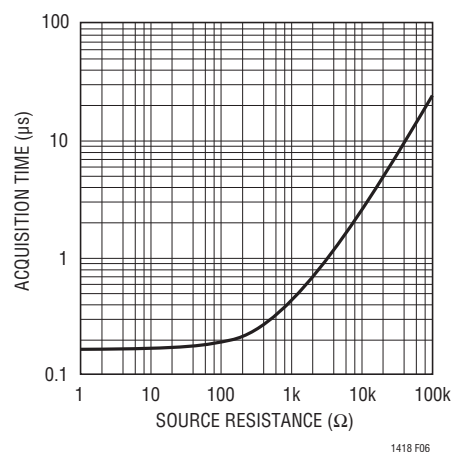

Figure 6. t_{ACQ} vs Source Resistance

APPLICATIONS INFORMATION

LT1630/LT1631: 30MHz, 10V/ μ s, Dual/Quad Rail-to-Rail Input and Output Precision Op Amps. 3.5mA supply current per amplifier. 2.7V to \pm 15V supplies. Best AC performance, input noise voltage = 6nV/ $\sqrt{\text{Hz}}$ (typ), THD = -86dB at 100kHz.

Input Filtering

The noise and the distortion of the input amplifier and other circuitry must be considered since they will add to the LTC1418 noise and distortion. The small-signal bandwidth of the sample-and-hold circuit is 5MHz. Any noise or distortion products that are present at the analog inputs will be summed over this entire bandwidth. Noisy input circuitry should be filtered prior to the analog inputs to minimize noise. A simple 1-pole RC filter is sufficient for many applications. For example, Figure 7 shows a 2000pF capacitor from $+A_{IN}$ to ground and a 100 Ω source resistor to limit the input bandwidth to 800kHz. The 2000pF capacitor also acts as a charge reservoir for the input sample-and-hold and isolates the ADC input from sampling glitch sensitive circuitry. High quality capacitors and resistors should be used since these components can add distortion. NPO and silver mica type dielectric capacitors have excellent linearity. Carbon surface mount resistors can also generate distortion from self heating and from damage that may occur during soldering. Metal film surface mount resistors are much less susceptible to both problems.

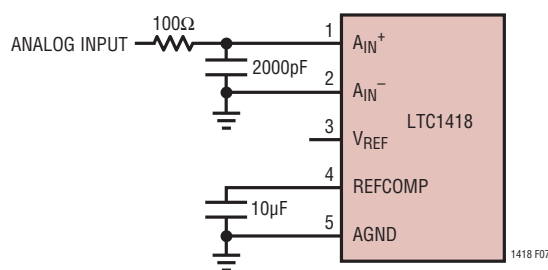

Figure 7. RC Input Filter

Input Range

The $\pm 2.048\text{V}$ and 0V to 4.096V input ranges of the LTC1418 are optimized for low noise and low distortion. Most op amps also perform well over these ranges, allowing direct coupling to the analog inputs and eliminating the need for special translation circuitry.

Some applications may require other input ranges. The LTC1418 differential inputs and reference circuitry can accommodate other input ranges often with little or no additional circuitry. The following sections describe the reference and input circuitry and how they affect the input range.

INTERNAL REFERENCE

The LTC1418 has an on-chip, temperature compensated, curvature corrected, bandgap reference which is factory trimmed to 2.500V. It is internally connected to a reference amplifier and is available at Pin 3. A 8k resistor is in series with the output so that it can be easily overdriven in applications where an external reference is required, see Figure 8. The reference amplifier compensation pin (REFCOMP, Pin 4) must be connected to a capacitor to ground. The reference is stable with capacitors of 1 μ F or greater. For the best noise performance, a 10 μ F in parallel with a 0.1 μ F ceramic is recommended.

The V_{REF} pin can be driven with a DAC or other means to provide input span adjustment. The reference should be kept in the range of 2.25V to 2.75V for specified linearity.

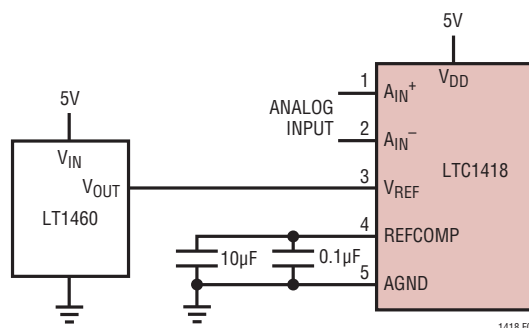

Figure 8. Using the LT1460 as an External Reference

APPLICATIONS INFORMATION

UNIPOLAR/BIPOLAR OPERATION AND ADJUSTMENT

Figure 9a shows the ideal input/output characteristics for the LTC1418. The code transitions occur midway between successive integer LSB values (i.e., 0.5LSB, 1.5LSB, 2.5LSB, ... FS – 1.5LSB). The output code is natural binary with 1LSB = FS/16384 = 4.096V/16384 = 250μV. Figure 9b shows the input/output transfer characteristics for the bipolar mode in two's complement format.

Unipolar Offset and Full-Scale Error Adjustment

In applications where absolute accuracy is important, offset and full-scale errors can be adjusted to zero. Offset error must be adjusted before full-scale error. Figures 10a and 10b show the extra components required for

full-scale error adjustment. Zero offset is achieved by adjusting the offset applied to the A_{IN-} input. For zero offset error apply 125μV (i.e., 0.5LSB) at the input and adjust the offset at the A_{IN-} input until the output code flickers between 0000 0000 0000 00 and 0000 0000 0000 01. For full-scale adjustment, an input voltage of 4.095625V (FS – 1.5LSBs) is applied to A_{IN+} and R2 is adjusted until the output code flickers between 1111 1111 1111 10 and 1111 1111 1111 11.

Bipolar Offset and Full-Scale Error Adjustment

Bipolar offset and full-scale errors are adjusted in a similar fashion to the unipolar case. Again, bipolar offset error must be adjusted before full-scale error. Bipolar offset

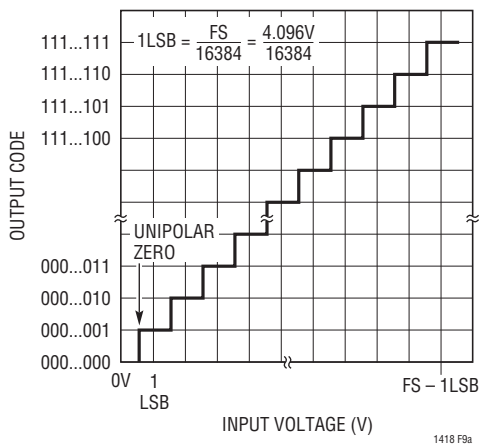

Figure 9a. LTC1418 Unipolar Transfer Characteristics

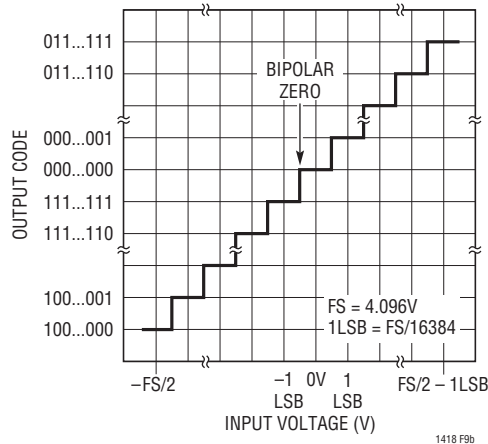

Figure 9b. LTC1418 Bipolar Transfer Characteristics

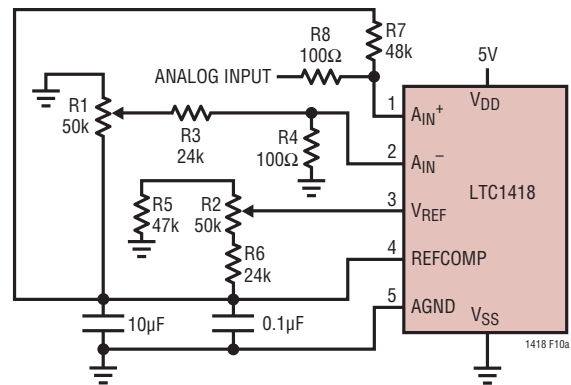

Figure 10a. Offset and Full-Scale Adjust Circuit if -5V is Not Available

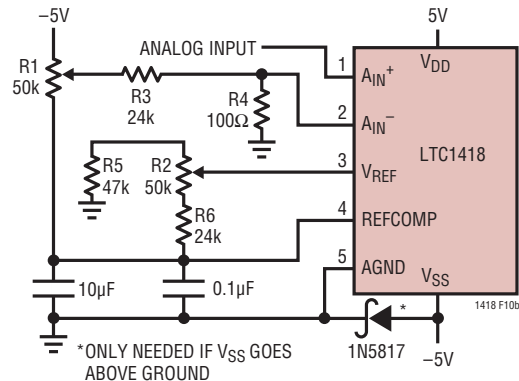

Figure 10b. Offset and Full-Scale Adjust Circuit if -5V is Available

APPLICATIONS INFORMATION

error adjustment is achieved by adjusting the offset applied to the A_{IN}^- input. For zero offset error apply $-125\mu\text{V}$ (i.e., -0.5LSB) at A_{IN}^+ and adjust the offset at the A_{IN}^- input until the output code flickers between 0000 0000 0000 00 and 1111 1111 1111 11. For full-scale adjustment, an input voltage of 2.047625V ($\text{FS} - 1.5\text{LSBs}$) is applied to A_{IN}^+ and R2 is adjusted until the output code flickers between 0111 1111 1111 10 and 0111 1111 1111 11.

BOARD LAYOUT AND GROUNDING

Wire wrap boards are not recommended for high resolution or high speed A/D converters. To obtain the best performance from the LTC1418, a printed circuit board with ground plane is required. The ground plane under the ADC area should be as free of breaks and holes as possible, such that a low impedance path between all ADC grounds and all ADC decoupling capacitors is provided. It is critical to prevent digital noise from being coupled to the analog input, reference or analog power supply lines. Layout should ensure that digital and analog signal lines are separated as much as possible. In particular, care should be taken not to run any digital track alongside an analog signal track.

An analog ground plane separate from the logic system ground should be established under and around the ADC. Pin 5 (AGND) and Pin 14 (DGND) and all other analog grounds should be connected to this single analog ground plane. The REFCOMP bypass capacitor and the V_{DD} bypass capacitor should also be connected to this analog ground plane. No other digital grounds should be connected to this analog ground plane. Low impedance analog and digital

power supply common returns are essential to low noise operation of the ADC and the foil width for these tracks should be as wide as possible. In applications where the ADC data outputs and control signals are connected to a continuously active microprocessor bus, it is possible to get errors in the conversion results. These errors are due to feedthrough from the microprocessor to the successive approximation comparator. The problem can be eliminated by forcing the microprocessor into a wait state during conversion or by using three-state buffers to isolate the ADC data bus. The traces connecting the pins and bypass capacitors must be kept short and should be made as wide as possible.

The LTC1418 has differential inputs to minimize noise coupling. Common mode noise on the A_{IN}^+ and A_{IN}^- leads will be rejected by the input CMRR. The A_{IN}^- input can be used as a ground sense for the A_{IN}^+ input; the LTC1418 will hold and convert the difference voltage between A_{IN}^+ and A_{IN}^- . The leads to A_{IN}^+ (Pin 1) and A_{IN}^- (Pin 2) should be kept as short as possible. In applications where this is not possible, the A_{IN}^+ and A_{IN}^- traces should be run side by side to equalize coupling.

SUPPLY BYPASSING

High quality, low series resistance ceramic, $10\mu\text{F}$ bypass capacitors should be used at the V_{DD} and REFCOMP pins. Surface mount ceramic capacitors such as Murata GRM235Y5V106Z016 provide excellent bypassing in a small board space. Alternatively $10\mu\text{F}$ tantalum capacitors in parallel with $0.1\mu\text{F}$ ceramic capacitors can be used.

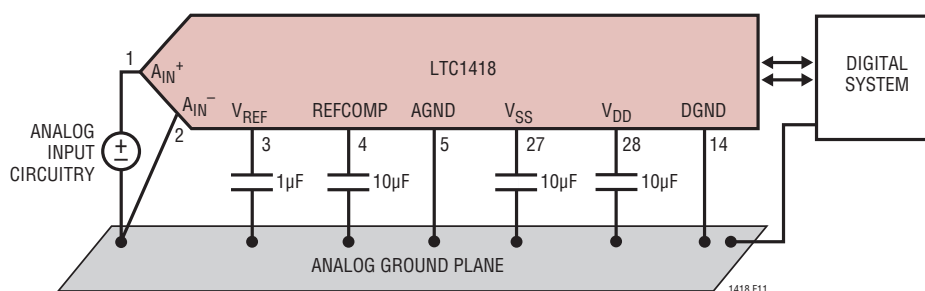
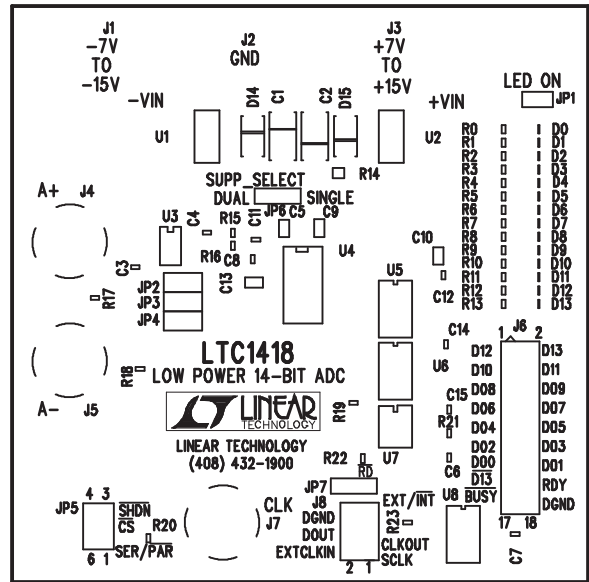

Figure 11. Power Supply Grounding Practice

APPLICATIONS INFORMATION



1418 F12b

Figure 12b. Suggested Evaluation Circuit Board— Component Side Top Silkscreen

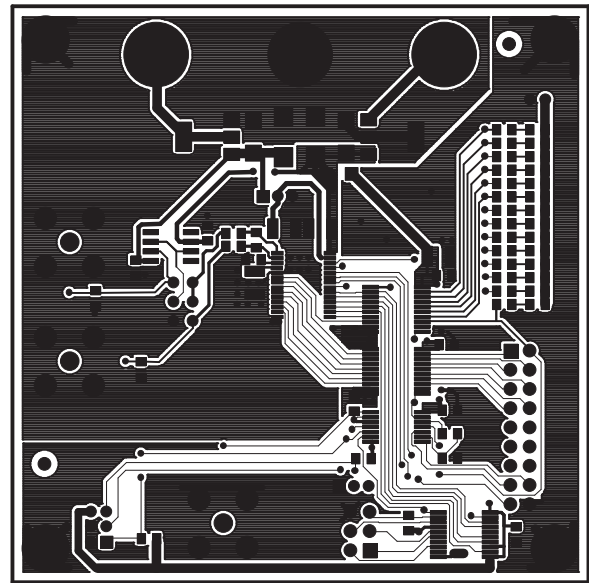

1418 F12c

Figure 12c. Suggested Evaluation Circuit Board—Top Layer

APPLICATIONS INFORMATION

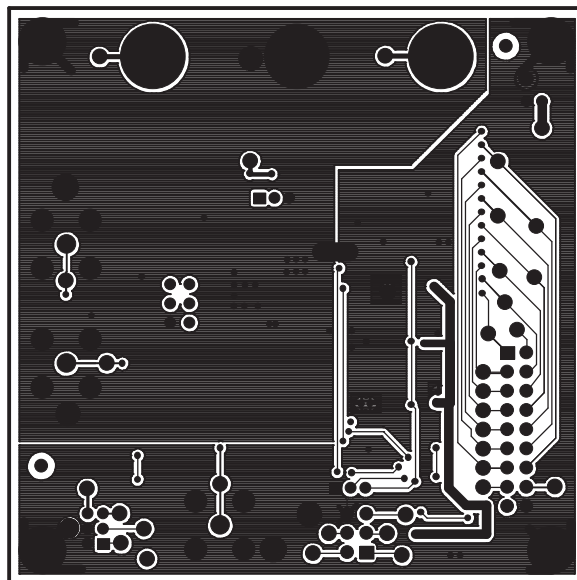

1418 F12d

Figure 12d. Suggested Evaluation Circuit Board—Solder Side Layout

Bypass capacitors must be located as close to the pins as possible. The traces connecting the pins and the bypass capacitors must be kept short and should be made as wide as possible.

Example Layout

Figures 12a, 12b, 12c and 12d show the schematic and layout of a suggested evaluation board. The layout demonstrates the proper use of decoupling capacitors and ground plane with a 2-layer printed circuit board.

DIGITAL INTERFACE

The LTC1418 can operate in serial or parallel mode. In parallel mode the ADC is designed to interface with microprocessors as a memory mapped device. The \overline{CS} and \overline{RD} control inputs are common to all peripheral memory interfacing. In serial mode only four digital interface lines are required, SCLK, CONVST, EXTCLKIN and D_{OUT} . SCLK, the serial data shift clock can be an external input or supplied by the LTC1418 internal clock.

Internal Clock

The ADC has an internal clock. In parallel output mode, the internal clock is always used as the conversion clock. In

serial output mode either the internal clock or an external clock may be used as the conversion clock (see Figure 20). The internal clock is factory trimmed to achieve a typical conversion time of $3.4\mu\text{s}$ and a maximum conversion time over the full operating temperature range of $4\mu\text{s}$. No external adjustments are required, and with the guaranteed maximum acquisition time of $1\mu\text{s}$, throughput performance of 200ksps is assured.

Power Shutdown

The LTC1418 provides two power shutdown modes, nap and sleep, to save power during inactive periods. The nap mode reduces the power by 80% and leaves only the digital logic and reference powered up. The wake-up time from nap to active is 500ns (see Figure 13a). In sleep mode all bias currents are shut down and only leakage current remains—about $2\mu\text{A}$. Wake-up time from sleep mode is much slower since the reference circuit must power up and settle to 0.005% for full 14-bit accuracy. Sleep mode wake-up time is dependent on the value of the capacitor connected to the REFCOMP (Pin 4). The wake-up time is 30ms with the recommended $10\mu\text{F}$ capacitor. Shutdown is controlled by Pin 22 (SHDN); the ADC is in shutdown when it is low. The shutdown mode is selected with Pin 25 (\overline{CS}); low selects nap (see Figure 13b), high selects sleep.

1418fa

APPLICATIONS INFORMATION

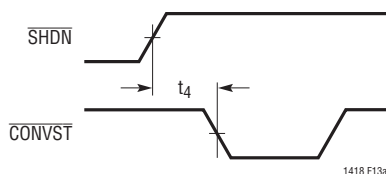

Figure 13a. $\overline{\text{SHDN}}$ to $\overline{\text{CONVST}}$ Wake-Up Timing

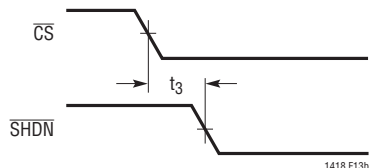

Figure 13b. $\overline{\text{CS}}$ to $\overline{\text{SHDN}}$ Timing

Conversion Control

Conversion start is controlled by the $\overline{\text{CS}}$ and $\overline{\text{CONVST}}$ inputs. A falling edge of $\overline{\text{CONVST}}$ pin will start a conversion after the ADC has been selected (i.e., $\overline{\text{CS}}$ is low, see Figure 14). Once initiated, it cannot be restarted until the conversion is complete. Converter status is indicated by the $\overline{\text{BUSY}}$ output. $\overline{\text{BUSY}}$ is low during a conversion.

Data Output

The data format is controlled by the $\overline{\text{SER/PAR}}$ input pin; logic low selects parallel output format. In parallel mode, the 14-bit data output word D0 to D13 is updated at the end of each conversion on Pins 6 to 13 and Pins 15 to 20. A logic high applied to $\overline{\text{SER/PAR}}$ selects the serial formatted data output and Pins 16 to 20 assume their serial function, Pins 6 to 13 and 15 are in the Hi-Z state. In either parallel or serial data formats, outputs will be active only when $\overline{\text{CS}}$ and $\overline{\text{RD}}$ are low. Any other combination of $\overline{\text{CS}}$ and $\overline{\text{RD}}$ will three-state the output. In unipolar mode ($V_{\text{SS}} = 0\text{V}$) the data will be in straight binary format (corresponding to the unipolar input range). In bipolar mode ($V_{\text{SS}} = -5\text{V}$), the data will be in two's complement format (corresponding to the bipolar input range).

Parallel Output Mode

Parallel mode is selected with a logic 0 applied to the $\overline{\text{SER/PAR}}$ pin. Figures 15 through 19 show different modes of parallel output operation. In modes 1a and 1b (Figures 15 and 16) $\overline{\text{CS}}$ and $\overline{\text{RD}}$ are both tied low. The falling edge of $\overline{\text{CONVST}}$ starts the conversion. The

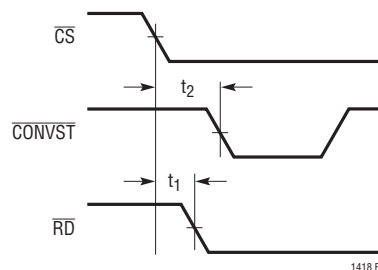

Figure 14. $\overline{\text{CS}}$ to $\overline{\text{CONVST}}$ Set-Up Timing

data outputs are always enabled and data can be latched with the $\overline{\text{BUSY}}$ rising edge. Mode 1a shows operation with a narrow logic low $\overline{\text{CONVST}}$ pulse. Mode 1b shows a narrow logic high $\overline{\text{CONVST}}$ pulse.

In mode 2 (Figure 17) $\overline{\text{CS}}$ is tied low. The falling edge of $\overline{\text{CONVST}}$ signal again starts the conversion. Data outputs are in three-state until read by the MPU with the $\overline{\text{RD}}$ signal. Mode 2 can be used for operation with a shared data bus.

In slow memory and ROM modes (Figures 18 and 19), $\overline{\text{CS}}$ is tied low and $\overline{\text{CONVST}}$ and $\overline{\text{RD}}$ are tied together. The MPU starts the conversion and reads the output with the $\overline{\text{RD}}$ signal. Conversions are started by the MPU or DSP (no external sample clock).

In slow memory mode the processor takes $\overline{\text{RD}} (= \overline{\text{CONVST}})$ low and starts the conversion. $\overline{\text{BUSY}}$ goes low forcing the processor into a wait state. The previous conversion result appears on the data outputs. When the conversion is complete, the new conversion results appear on the data outputs; $\overline{\text{BUSY}}$ goes high releasing the processor and the processor takes $\overline{\text{RD}} (= \overline{\text{CONVST}})$ back high and reads the new conversion data.

In ROM mode, the processor takes $\overline{\text{RD}} (= \overline{\text{CONVST}})$ low, starting a conversion and reading the previous conversion result. After the conversion is complete, the processor can read the new result and initiate another conversion.

Serial Output Mode

Serial output mode is selected when the $\overline{\text{SER/PAR}}$ input pin is high. In this mode, Pins 16 to 20, D0 ($\overline{\text{EXT/INT}}$), D1 (D_{OUT}), D2 (CLK_{OUT}), D3 (SCLK) and D4 ($\overline{\text{EXTCLKIN}}$) assume their serial functions as shown in Figure 20. (During this discussion, these pins will be referred to by their

APPLICATIONS INFORMATION

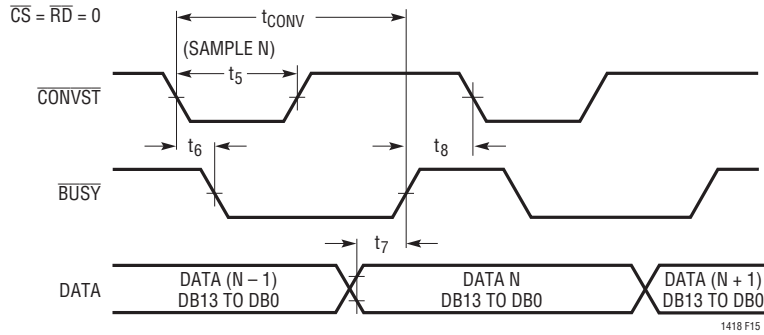

Figure 15. Mode 1a. \overline{CONVST} Starts a Conversion. Data Outputs Always Enabled ($\overline{CONVST} = \square$)

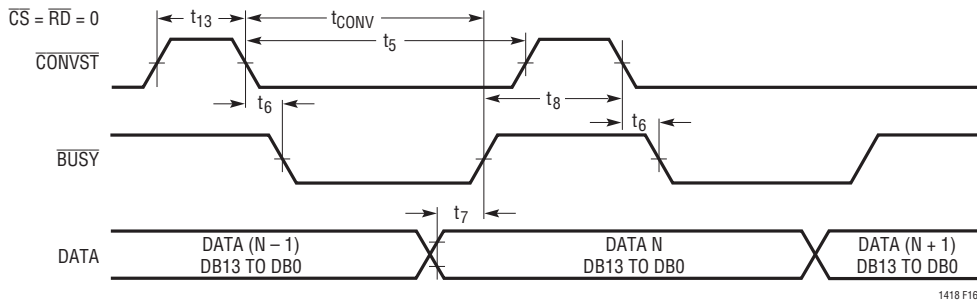

Figure 16. Mode 1b. \overline{CONVST} Starts a Conversion. Data Outputs Always Enabled ($\overline{CONVST} = \square$)

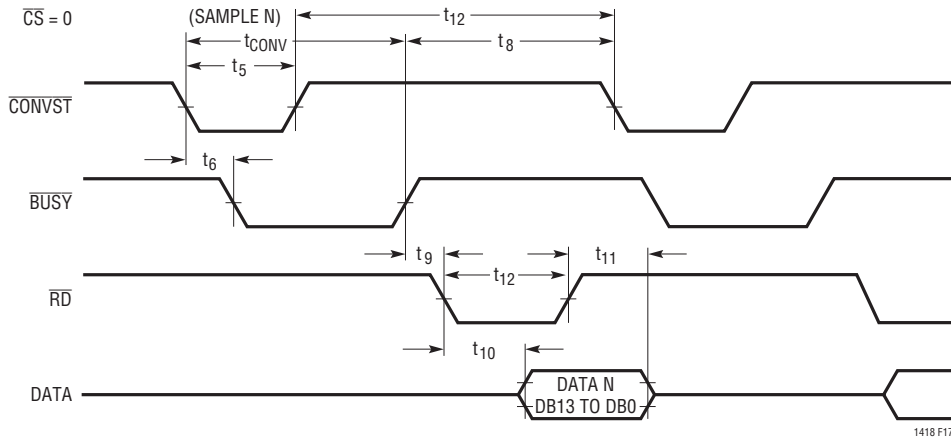

Figure 17. Mode 2. \overline{CONVST} Starts a Conversion. Data is Read by \overline{RD}

APPLICATIONS INFORMATION

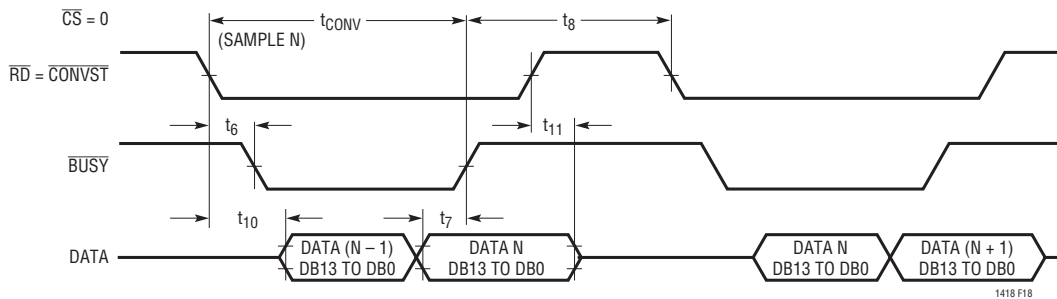

Figure 18. Slow Memory Mode Timing

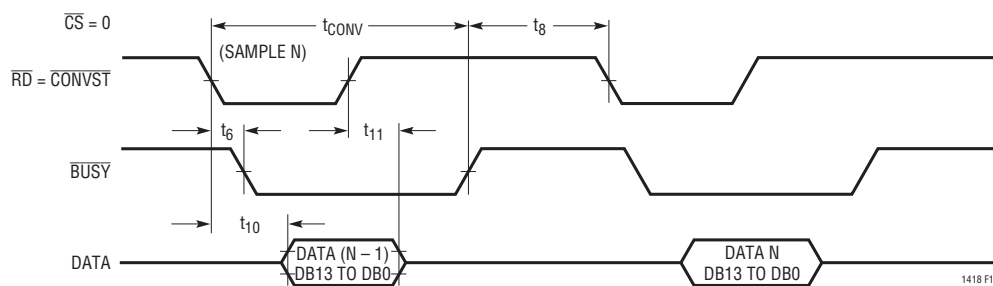

Figure 19. ROM Mode Timing

serial function names: $\overline{\text{EXT/INT}}$, D_{OUT} , CLKOUT , SCLK and EXTCLKIN .) As in parallel mode, conversions are started by a falling $\overline{\text{CONVST}}$ edge with $\overline{\text{CS}}$ low. After a conversion is completed and the output shift register has been updated, $\overline{\text{BUSY}}$ will go high and valid data will be available on D_{OUT} (Pin 19). This data can be clocked out either before the next conversion starts or it can be clocked out during the next conversion. To enable the serial data output buffer and shift clock, $\overline{\text{CS}}$ and $\overline{\text{RD}}$ must be low.

Figure 20 shows a function block diagram of the LTC1418 in serial mode. There are two pieces to this circuitry: the conversion clock selection circuit ($\overline{\text{EXT/INT}}$, EXTCLKIN and CLKOUT) and the serial port (SCLK , D_{OUT} , $\overline{\text{CS}}$ and $\overline{\text{RD}}$).

Conversion Clock Selection (Serial Mode)

In Figure 20, the conversion clock controls the internal ADC operation. The conversion clock can be either internal or external. By connecting $\overline{\text{EXT/INT}}$ low, the internal clock is selected. This clock generates 16 clock cycles which feed into the SAR for each conversion.

To select an external conversion clock, tie $\overline{\text{EXT/INT}}$ high and apply an external conversion clock to EXTCLKIN (Pin 16). (When an external shift clock (SCLK) is used

during a conversion, the SCLK should be used as the external conversion clock to avoid the noise generated by the asynchronous clocks. To maintain accuracy the external conversion clock frequency must be between 30kHz and 4.5MHz.) The SAR sends an end of conversion signal, $\overline{\text{EOC}}$, that gates the external conversion clock so that only 16 clock cycles can go into the SAR, even if the external clock, EXTCLKIN , contains more than 16 cycles.

When $\overline{\text{CS}}$ and $\overline{\text{RD}}$ are low, these 16 cycles of conversion clock (whether internally or externally generated) will appear on CLKOUT during each conversion and then CLKOUT will remain low until the next conversion. If desired, CLKOUT can be used as a master clock to drive the serial port. Because CLKOUT is running during the conversion, it is important to avoid excessive loading that can cause large supply transients and create noise. For the best performance, limit CLKOUT loading to 20pF.

Serial Port

The serial port in Figure 20 is made up of a 16-bit shift register and a three-state output buffer that are controlled by three inputs: SCLK , $\overline{\text{RD}}$ and $\overline{\text{CS}}$. The serial port has one output, D_{OUT} , that provides the serial output data.

APPLICATIONS INFORMATION

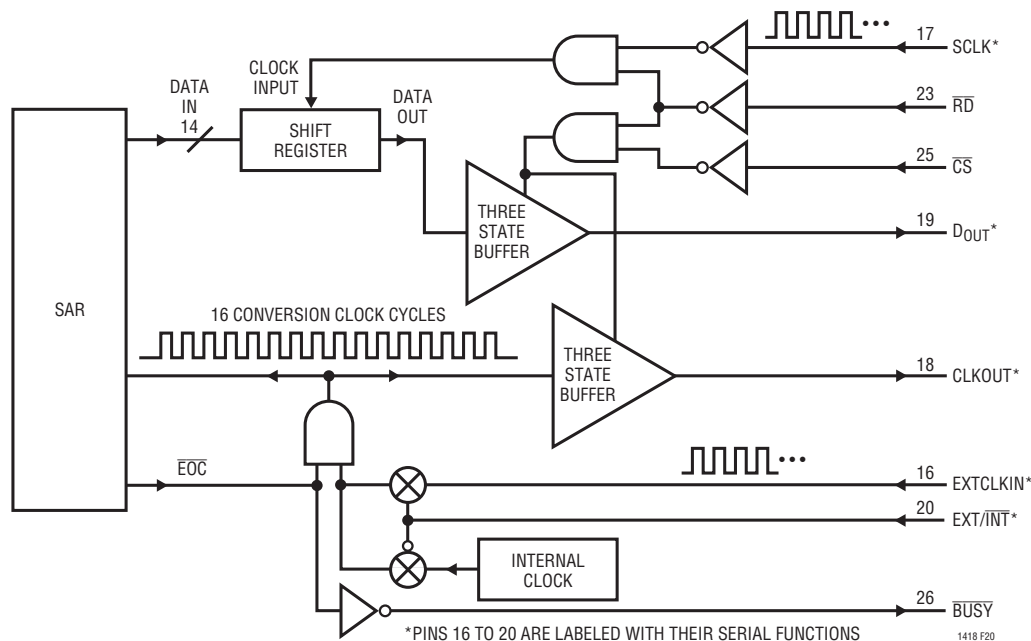

Figure 20. Functional Block Diagram for Serial Mode ($SER/\overline{PAR} = \text{High}$)

The SCLK is used to clock the shift register. Data may be clocked out with the internal conversion clock operating as a master by connecting CLKOUT (Pin 18) to SCLK (Pin 17) or with an external data clock applied to D3 (SCLK). The minimum number of SCLK cycles required to transfer a data word is 14. Normally, SCLK contains 16 clock cycles for a word length of 16 bits; 14 bits with MSB first, followed by two trailing zeros.

A logic high on \overline{RD} disables SCLK and three-states D_{OUT} . In case of using a continuous SCLK, \overline{RD} can be controlled to limit the number of shift clocks to the desired number (i.e., 16 cycles) and to three-state D_{OUT} after the data transfer.

A logic high on \overline{CS} three-states the D_{OUT} output buffer. It also inhibits conversion when it is tied high. In power shutdown mode ($SHDN = \text{low}$), a high \overline{CS} selects sleep mode while a low \overline{CS} selects nap mode. For normal serial port operation, \overline{CS} can be grounded.

D_{OUT} outputs the serial data; 14 bits, MSB first, on the falling edge of each SCLK (see Figures 21 and 22). If 16 SCLKs are provided, the 14 data bits will be followed by two zeros. The MSB (D13) will be valid on the first rising and the first falling edge of the SCLK. D12 will be valid on the second rising and the second falling edge as

will all the remaining bits. The data may be captured on either edge. The largest hold time margin is achieved if data is captured on the rising edge of SCLK.

\overline{BUSY} gives the end of conversion indication. When the LTC1418 is configured as a master serial device, \overline{BUSY} can be used as a framing pulse and to three-state the serial port after transferring the serial output data by tying it to the \overline{RD} pin.

Figures 22 to 25 show several serial modes of operation, demonstrating the flexibility of the LTC1418 serial port.

SERIAL DATA OUTPUT DURING A CONVERSION

Using Internal Conversion Clock for Conversion and Data Transfer

Figure 22 shows data from the previous conversion being clocked out during the conversion with the LTC1418 internal clock providing both the conversion clock and the SCLK. The internal clock has been optimized for the fastest conversion time, consequently this mode can provide the best overall speed performance. To select an internal conversion clock, tie EXT/INT (Pin 20) low. The internal

APPLICATIONS INFORMATION

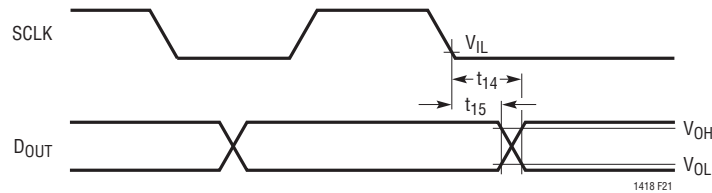

Figure 21. SCLK to D_{OUT} Delay

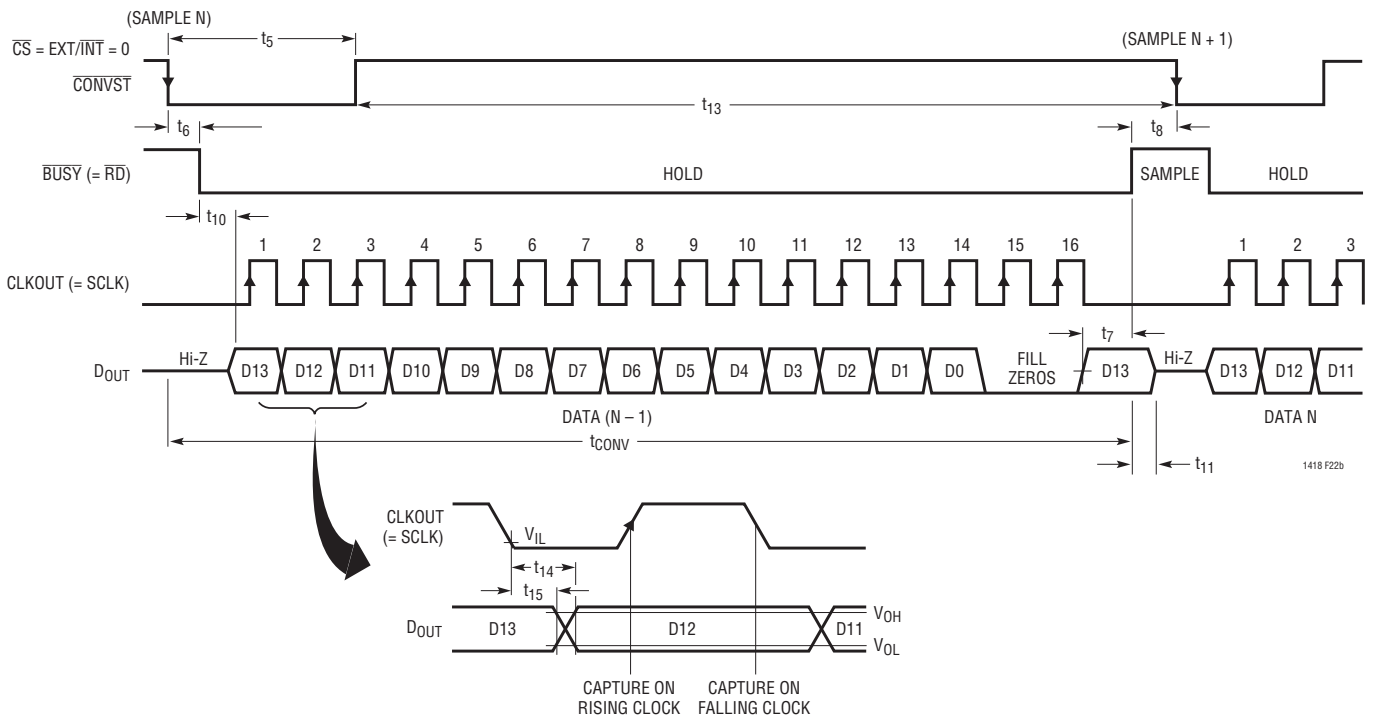
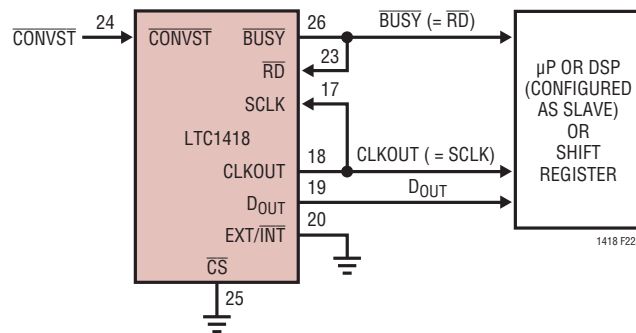

Figure 22. Internal Conversion Clock Selected. Data Transferred During Conversion Using the ADC Clock Output as a Master Shift Clock (SCLK Driven from CLKOUT)

APPLICATIONS INFORMATION

clock appears on CLKOUT (Pin 18) which can be tied to SCLK (Pin 17) to supply the SCLK.

Using External Clock for Conversion and Data Transfer

In Figure 23, data from the previous conversion is output during the conversion with an external clock providing both the conversion clock and the shift clock. To select an external conversion clock, tie EXT/INT high and apply the clock to EXTCLKIN. The same clock is also applied to SCLK to provide a data shift clock. To maintain accuracy the conversion clock frequency must be between 30kHz and 4.5MHz.

It is not recommended to clock data with an external clock during a conversion that is running on an internal clock because the asynchronous clocks may create noise.

Serial Data Output After a Conversion

Using Internal Conversion Clock and External Data Clock. In this mode, data is output after the end of each conversion but before the next conversion is started (Figure 24). The internal clock is used as the conversion clock and an external clock is used for the SCLK. This mode is useful in applications where the processor acts as a master serial device. This mode is SPI and MICROWIRE compatible. It also allows operation when the SCLK frequency is very low

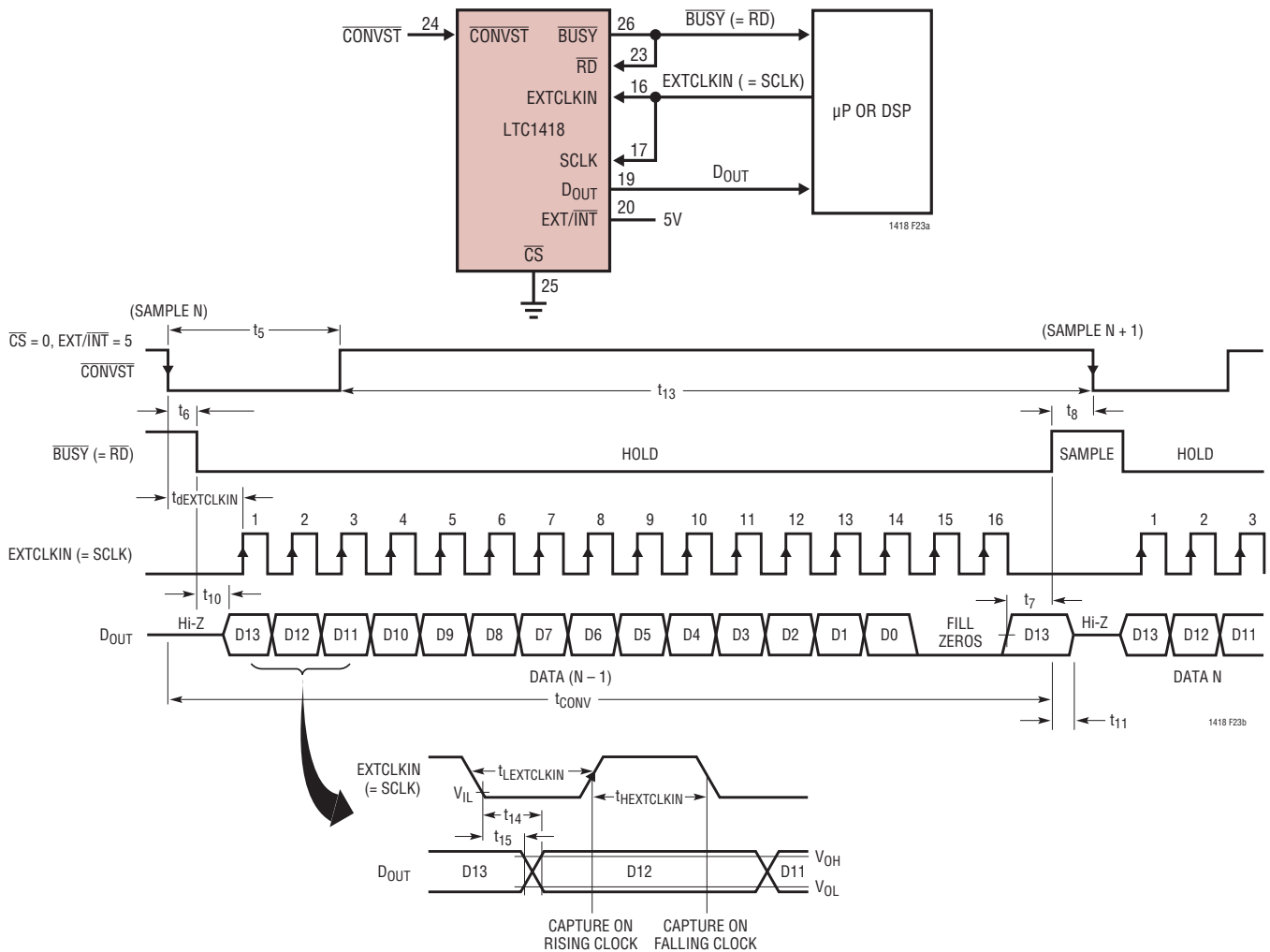

Figure 23. External Conversion Clock Selected. Data Transferred During Conversion Using the External Clock (External Clock Drives Both EXTCLKIN and SCLK)

APPLICATIONS INFORMATION

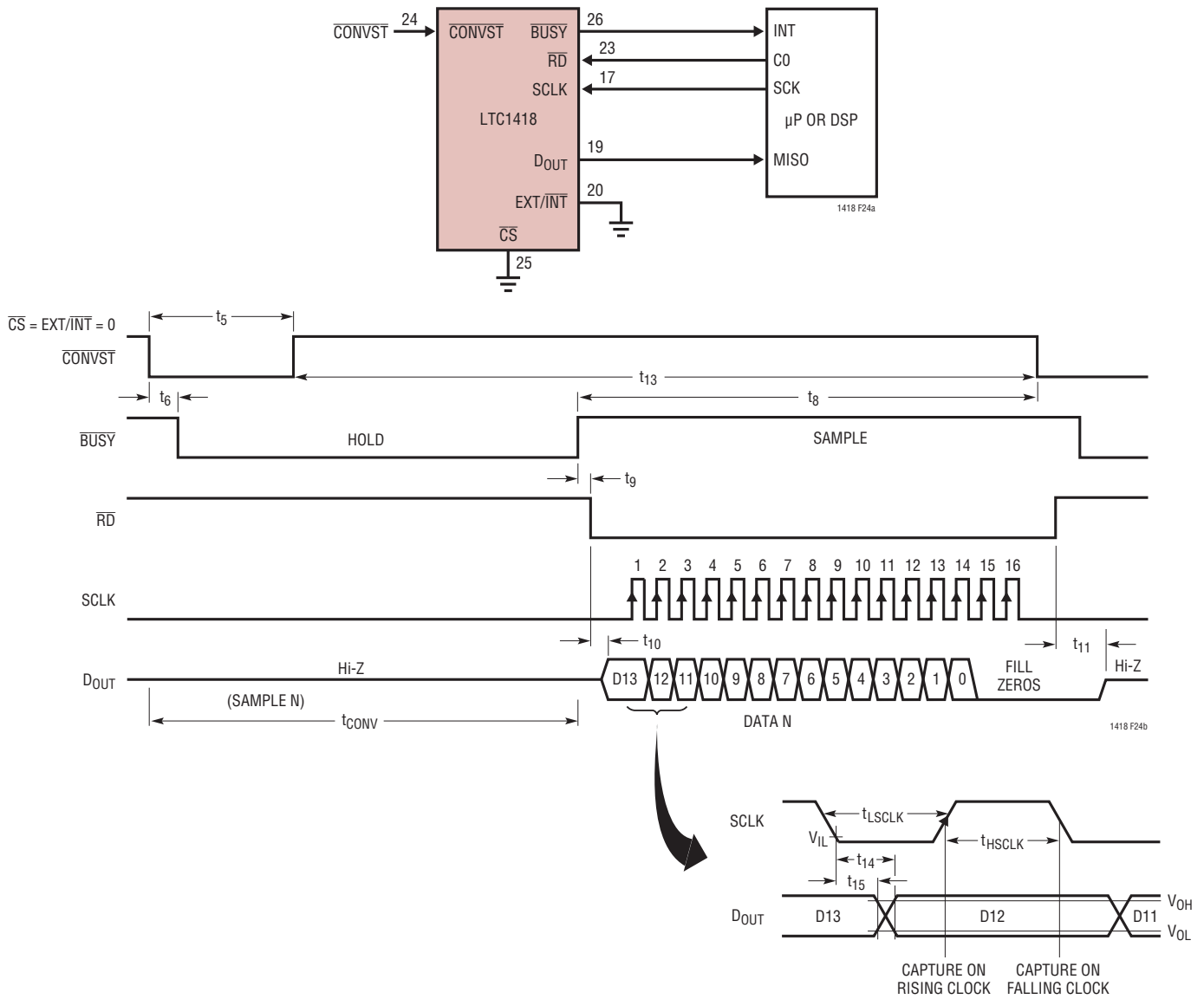

Figure 24. Internal Conversion Clock Selected. Data Transferred After Conversion Using an External SCLK. $\overline{\text{BUSY}}\uparrow$ Indicates End of Conversion

APPLICATIONS INFORMATION

(less than 30kHz). To select the internal conversion clock tie EXT/INT low. The external SCLK is applied to SCLK. RD can be used to gate the external SCLK, such that data will clock only after \overline{RD} goes low and to three-state D_{OUT} after data transfer. If more than 16 SCLKs are provided, more zeros will be filled in after the data word indefinitely.

Using External Conversion Clock and External Data Clock

In Figure 25, data is also output after each conversion is completed and before the next conversion is started. An external clock is used for the conversion clock and either another or the same external clock is used for the SCLK. This mode is

identical to Figure 24 except that an external clock is used for the conversion. This mode allows the user to synchronize the A/D conversion to an external clock either to have precise control of the internal bit test timing or to provide a precise conversion time. As in Figure 24, this mode works when the SCLK frequency is very low (less than 30kHz). However, the external conversion clock must be between 30kHz and 4.5MHz to maintain accuracy. If more than 16 SCLKs are provided, more zeros will be filled in after the data word indefinitely. To select the external conversion clock tie EXT/INT high. The external SCLK is applied to SCLK. \overline{RD} can be used to gate the external SCLK such that data will clock only after \overline{RD} goes low.

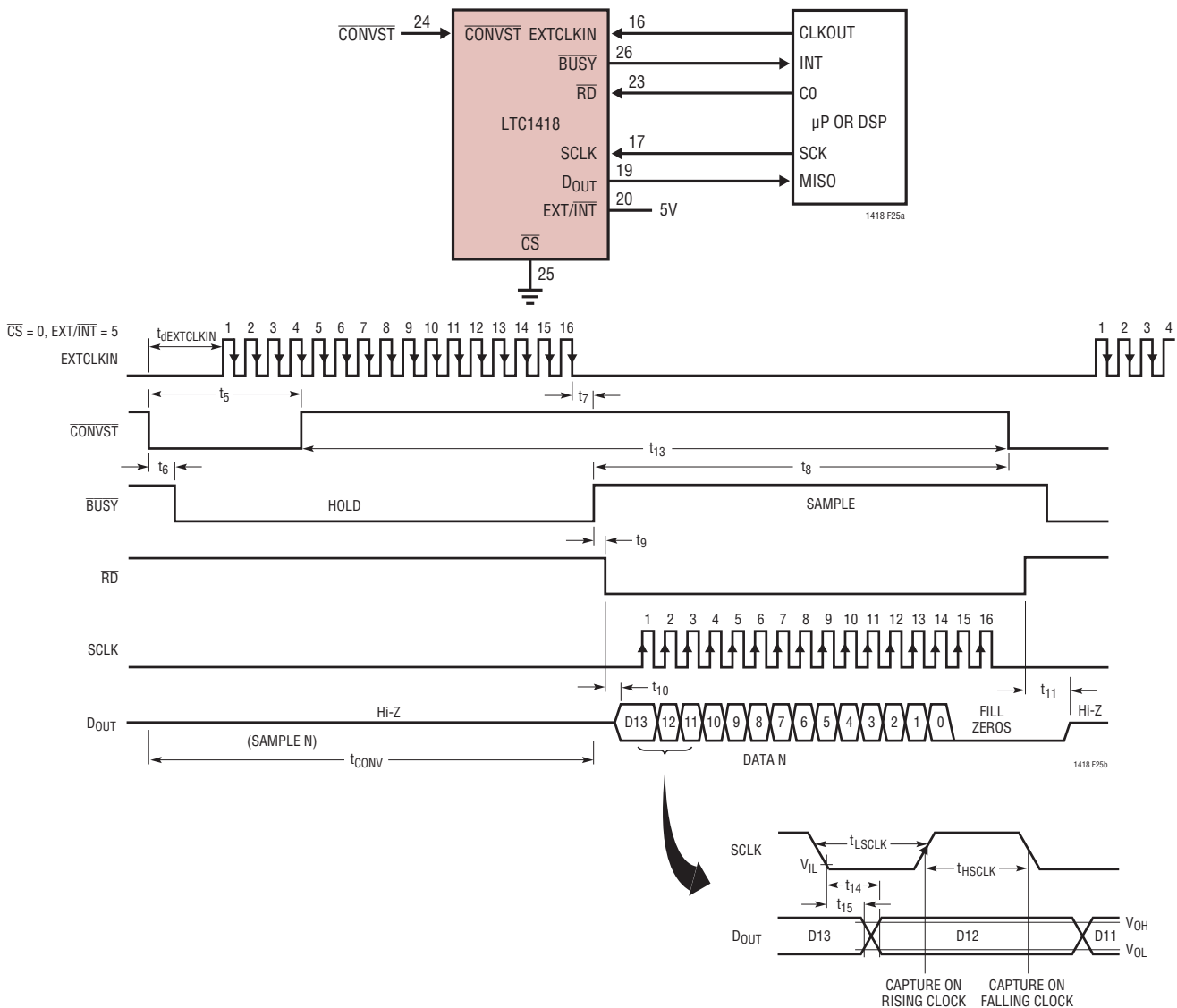

Figure 25. External Conversion Clock Selected. Data Transferred After Conversion Using an External SCLK. \overline{BUSY} ↑ Indicates End of Conversion

1418fa

PACKAGE DESCRIPTION

Please refer to <http://www.linear.com/designtools/packaging/> for the most recent package drawings.

G Package 28-Lead Plastic SSOP (5.3mm) (Reference LTC DWG # 05-08-1640)

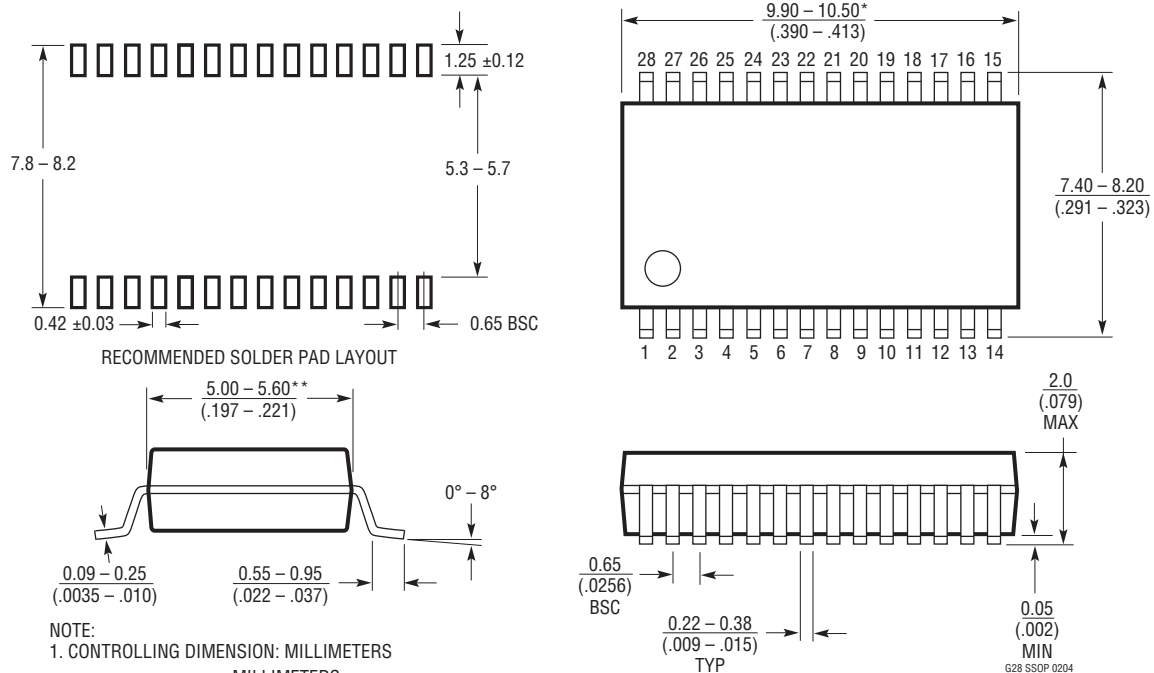

PACKAGE DESCRIPTION

Please refer to <http://www.linear.com/designtools/packaging/> for the most recent package drawings.

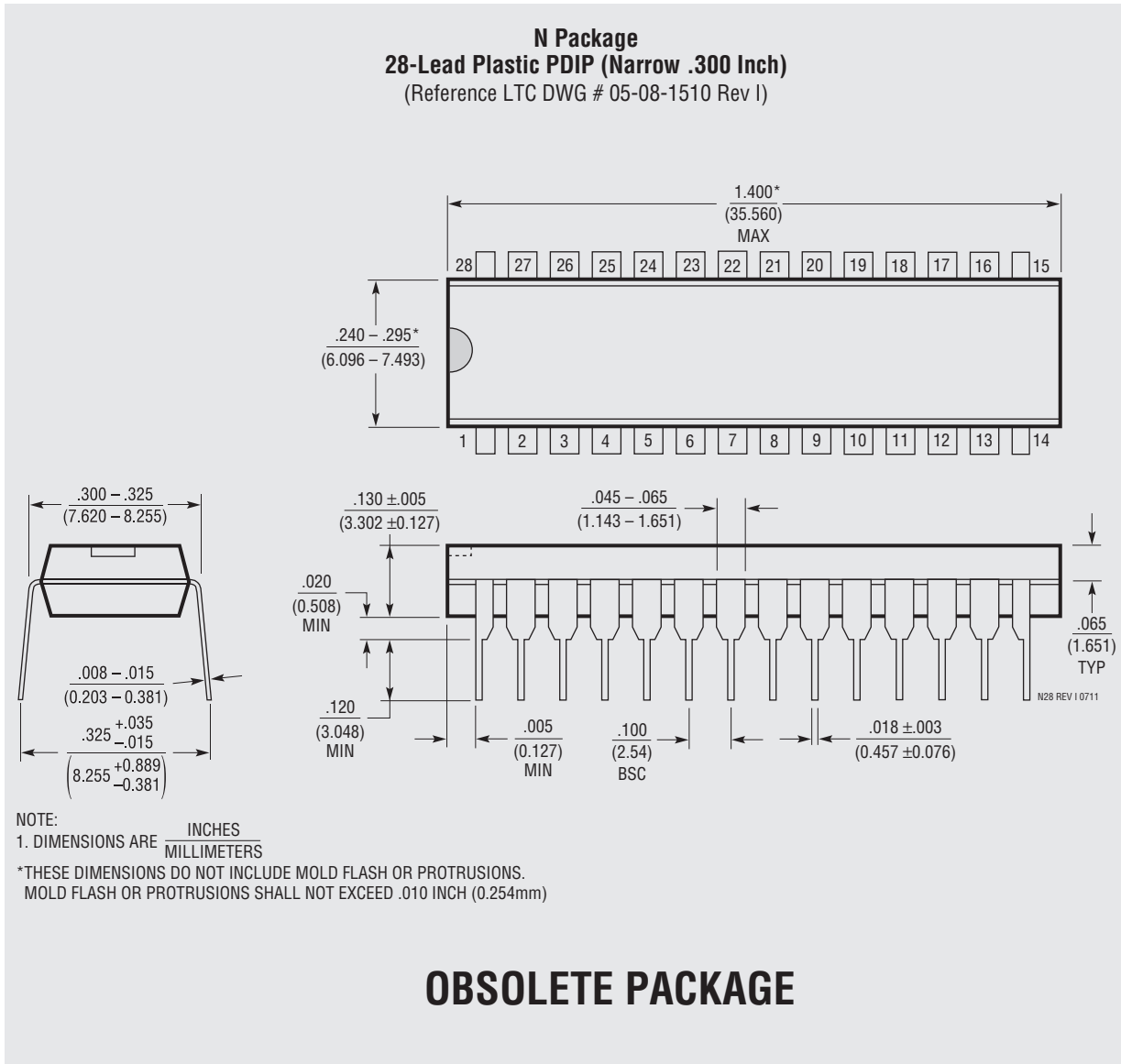

NOTE:
 1. DIMENSIONS ARE $\frac{\text{INCHES}}{\text{MILLIMETERS}}$
 *THESE DIMENSIONS DO NOT INCLUDE MOLD FLASH OR PROTRUSIONS.
 MOLD FLASH OR PROTRUSIONS SHALL NOT EXCEED .010 INCH (0.254mm)

REVISION HISTORY

REV	DATE	DESCRIPTION	PAGE NUMBER
A	07/15	Obsoleted 28-Lead PDIP Package	2, 28

LTC1418

TYPICAL APPLICATION

Single 5V Supply, 200kHz, 14-Bit Sampling A/D Converter

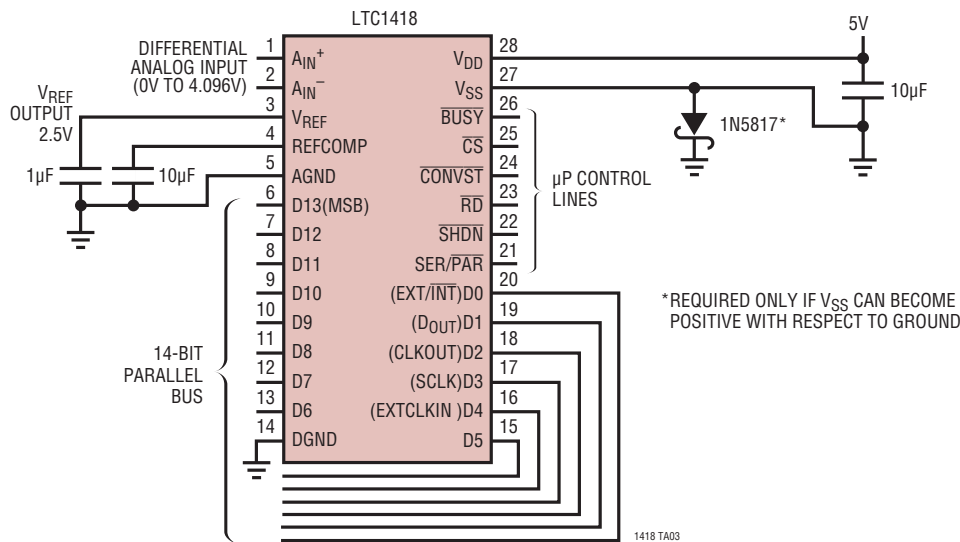

RELATED PARTS

PART NUMBER	DESCRIPTION	COMMENTS
ADCs		
LTC1274/LTC1277	Low Power, 12-Bit, 100ksps ADCs	10mW Power Dissipation, Parallel/Byte Interface
LTC1412	12-Bit, 3Msps Sampling ADC	Best Dynamic Performance, SINAD = 72dB at Nyquist
LTC1415	Single 5V, 12-Bit, 1.25Msps ADC	55mW Power Dissipation, 72dB SINAD
LTC1416	Low Power, 14-Bit, 400ksps ADC	70mW Power Dissipation, 80.5dB SINAD
LTC1419	Low Power, 14-Bit, 800ksps ADC	True 14-Bit Linearity, 81.5dB SINAD, 150mW Dissipation
LTC1604	16-Bit, 333ksps Sampling ADC	±2.5V Input, SINAD = 90dB, THD = 100dB
LTC1605	Single 5V, 16-Bit, 100ksps ADC	Low Power, ±10V Inputs, Parallel/Byte Interface
DACs		
LTC1595	16-Bit CMOS Multiplying DAC in SO-8	±1LSB Max INL/DNL, 1nV • sec Glitch, DAC8043 Upgrade
LTC1596	16-Bit CMOS Multiplying DAC	±1LSB Max INL/DNL, DAC8143/AD7543 Upgrade
Reference		
LT1019-2.5	Precision Bandgap Reference	0.05% Max, 5ppm/°C Max

Looking for pricing, stock, or lifecycle information?

Click below to explore more details on WIN SOURCE:

 [View LTC1418AIG#PBF on WIN SOURCE](#)

 [Linear Technology](#) Information

Optimize Your Supply Chain with WIN SOURCE Solutions

-  Global Sourcing Solution
-  Obsolete Management
-  Cost Control Management
-  Shortage Management
-  Alternative Solution
-  Excess Inventory Management