



**THE DATASHEET OF
LTC1383IS#TRPBF**



FEATURES

- Operates from a Single 5V Supply
- Low Supply Current: $I_{CC} = 220\mu A$
- ESD Protection Over $\pm 10kV$
- Available in 16-Pin SOIC Narrow Package
- Uses Small Capacitors: $0.1\mu F$
- Operates to 120kbaud
- Output Overvoltage Does Not Force Current Back into Supplies
- RS232 I/O Lines Can Be Forced to $\pm 25V$ Without Damage
- Pin Compatible with LT1181A and MAX232A

APPLICATIONS

- Notebook Computers
- Palmtop Computers

DESCRIPTION

The LTC[®]1383 is an ultra-low power 2-driver/2-receiver RS232 transceiver that operates from a single 5V supply. The charge pump requires only four space-saving $0.1\mu F$ capacitors. The supply current (I_{CC}) of the transceiver is only $220\mu A$ with driver outputs unloaded.

The LTC1383 is fully compliant with all data rate and overvoltage RS232 specifications. The transceiver can operate up to 120kbaud with a $2500pF$, $3k\Omega$ load. Both driver outputs and receiver inputs can be forced to $\pm 25V$ without damage and can survive multiple $\pm 10kV$ ESD strikes.

 LTC and LT are registered trademarks of Linear Technology Corporation.

TYPICAL APPLICATION

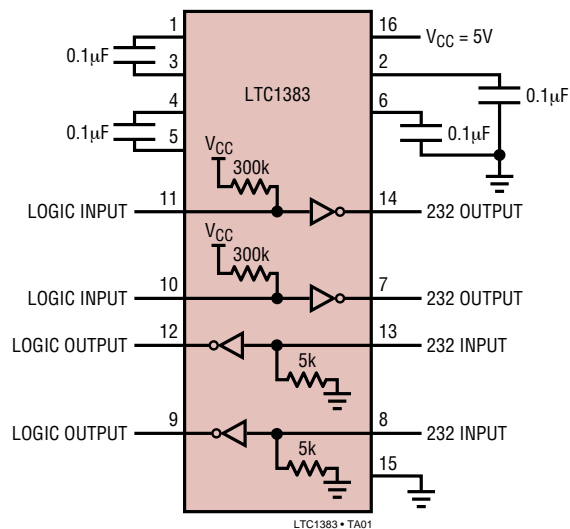

Quiescent Supply Current vs Temperature

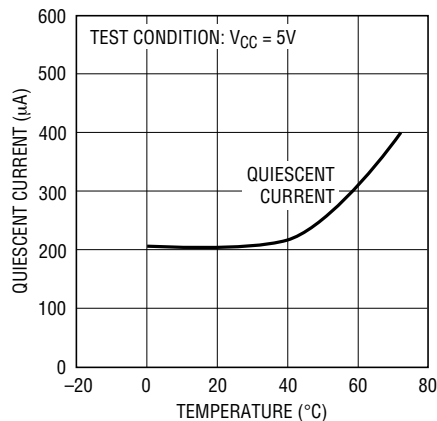

LTC1383 • TA02

ABSOLUTE MAXIMUM RATINGS

Supply Voltage (V_{CC}) 6V

Input Voltage

Driver $-0.3V$ to $V_{CC} + 0.3V$

Receiver $-25V$ to $25V$

Digital Input $-0.3V$ to $V_{CC} + 0.3V$

Output Voltage

Driver $-25V$ to $25V$

Receiver $-0.3V$ to $V_{CC} + 0.3V$

Short-Circuit Duration

V^+ 30 sec

V^- 30 sec

Driver Output Indefinite

Receiver Output Indefinite

Operating Temperature Range

LTC1383C $0^{\circ}C$ to $70^{\circ}C$

LTC1383I $-40^{\circ}C$ to $85^{\circ}C$

Storage Temperature Range $-65^{\circ}C$ to $150^{\circ}C$

Lead Temperature (Soldering, 10 sec) $300^{\circ}C$

PACKAGE/ORDER INFORMATION

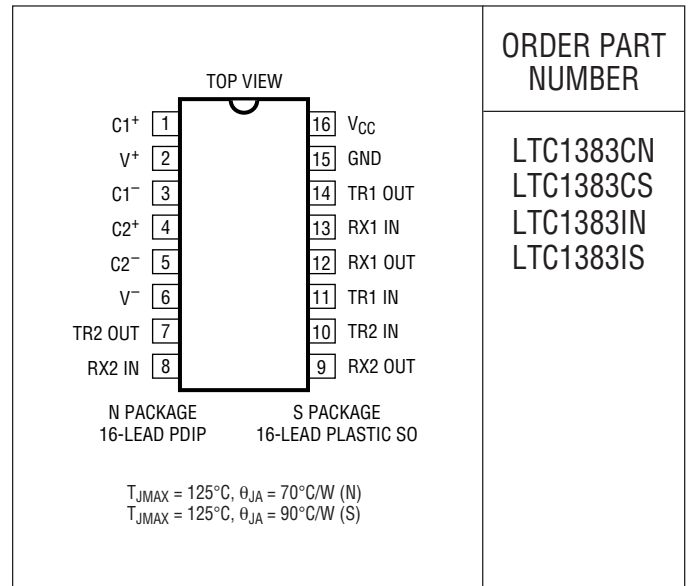

ORDER PART NUMBER

LTC1383CN
 LTC1383CS
 LTC1383IN
 LTC1383IS

Consult LTC Marketing for parts specified with wider operating temperature ranges.

DC ELECTRICAL CHARACTERISTICS

The ● denotes specifications which apply over the full operating temperature range, otherwise specifications are at $T_A = 25^{\circ}C$. $V_{CC} = 5V, C1 = C2 = C3 = C4 = 0.1\mu F$, unless noted.

PARAMETER	CONDITIONS	MIN	TYP	MAX	UNITS	
Any Driver						
Output Voltage Swing	3k to GND	Positive ● Negative ●	5.0 -5.0	7.0 -6.5	V V	
Logic Input Voltage Level	Input Low Level ($V_{OUT} = \text{High}$) Input High Level ($V_{OUT} = \text{Low}$)	● ●	1.4 2.0	0.8 1.4	V V	
Logic Input Current	$V_{IN} = V_{CC}$ $V_{IN} = 0V$	● ●		5 -20	μA μA	
Output Short-Circuit Current	$V_{OUT} = 0V$		± 9	± 12	mA	
Any Receiver						
Input Voltage Thresholds	Input Low Threshold Input High Threshold	● ●	0.8	1.3 1.7	V V	
Hysteresis		●	0.1	0.4	1	V
Input Resistance	$-10V \leq V_{IN} \leq 10V$		3	5	7	k Ω
Output Voltage	Output Low, $I_{OUT} = -1.6mA$ ($V_{CC} = 5V$) Output High, $I_{OUT} = 160\mu A$ ($V_{CC} = 5V$)	● ●		0.2 3.0	0.4	V V
Output Short-Circuit Current	Sinking Current, $V_{OUT} = V_{CC}$ Sourcing Current $V_{OUT} = 0V$		-15	-40	20	mA mA
Power Supply Generator						
V^+ Output Voltage	$I_{OUT} = 0mA$ $I_{OUT} = 8mA$			8.0 7.5	V V	
V^- Output Voltage	$I_{OUT} = 0mA$ $I_{OUT} = -8mA$			-8.0 -7.0	V V	

DC ELECTRICAL CHARACTERISTICS The ● denotes specifications which apply over the full operating temperature range, otherwise specifications are at $T_A = 25^\circ\text{C}$. $V_{CC} = 5\text{V}$, $C_1 = C_2 = C_3 = C_4 = 0.1\mu\text{F}$, unless noted.

PARAMETER	CONDITIONS	MIN	TYP	MAX	UNITS
Power Supply					
V_{CC} Supply Current	No Load (Note 2), 0°C to 70°C	●	0.22	0.5	mA
	No Load (Note 2), -40°C to 85°C	●	0.35	1.0	mA
Digital Input Threshold Low		●	1.4	0.8	V
Digital Input Threshold High		●	2.0	1.4	V

AC CHARACTERISTICS The ● denotes specifications which apply over the full operating temperature range, otherwise specifications are at $T_A = 25^\circ\text{C}$. $V_{CC} = 5\text{V}$, $C_1 = C_2 = C_3 = C_4 = 0.1\mu\text{F}$, unless noted.

PARAMETER	CONDITIONS	MIN	TYP	MAX	UNITS
Slew Rate	$R_L = 3\text{k}$, $C_L = 51\text{pF}$		8	30	$\text{V}/\mu\text{s}$
	$R_L = 3\text{k}$, $C_L = 2500\text{pF}$	3	5		$\text{V}/\mu\text{s}$
Driver Propagation Delay (TTL to RS232)	t_{HLD} (Figure 1)	●	2	3.5	μs
	t_{LHD} (Figure 1)	●	2	3.5	μs
Receiver Propagation Delay (RS232 to TTL)	t_{HLR} (Figure 2)	●	0.3	0.8	μs
	t_{LHR} (Figure 2)	●	0.3	0.8	μs

Note 1: Absolute Maximum Ratings are those values beyond which the life of the device may be impaired.

Note 2: Supply current is measured with driver and receiver outputs unloaded.

TYPICAL PERFORMANCE CHARACTERISTICS

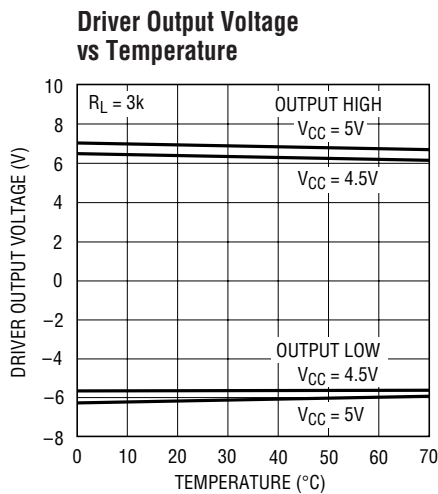

LTC1383 • TPC01

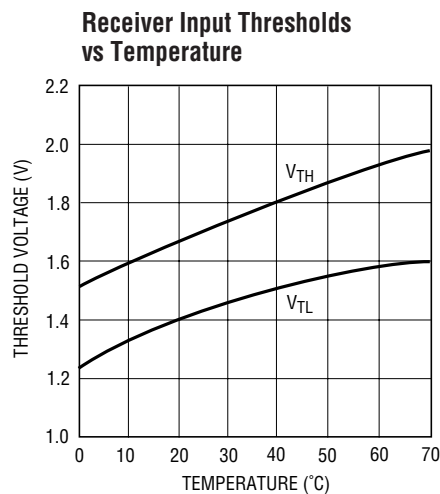

LTC1383 • TPC02

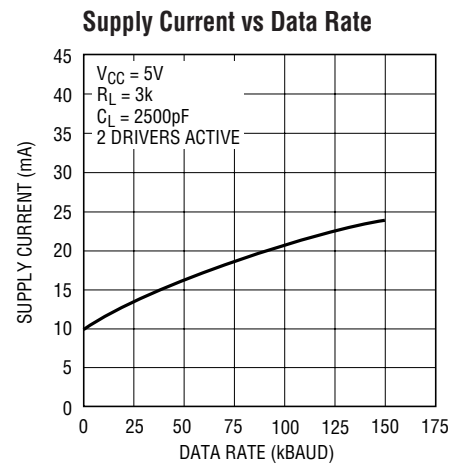

LTC1383 • TPC03

TYPICAL PERFORMANCE CHARACTERISTICS

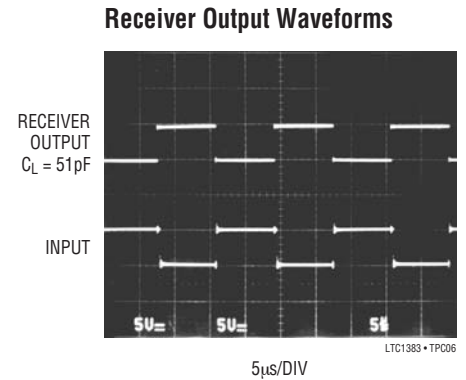
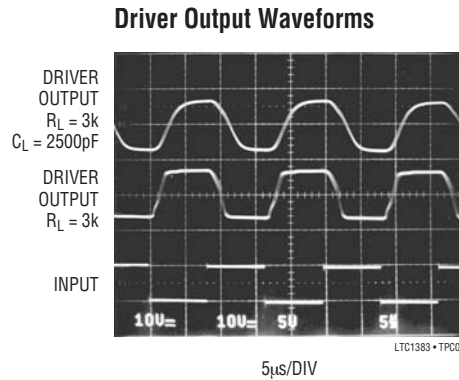
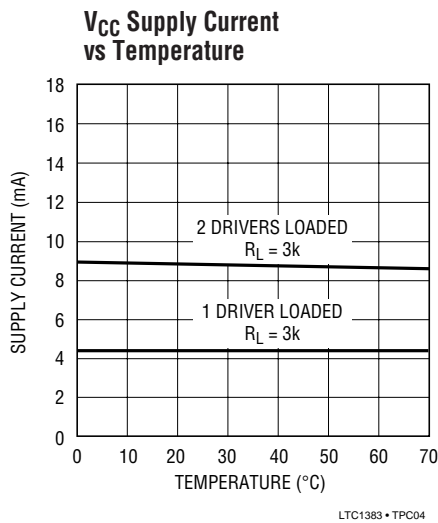

PIN FUNCTIONS

V_{CC}: 5V Input Supply Pin. This pin should be decoupled with a 0.1µF ceramic capacitor.

GND: Ground Pin.

V⁺: Positive Supply Output (RS232 Drivers). $V^+ \cong 2V_{CC} - 2V$. This pin requires an external capacitor $C = 0.1\mu\text{F}$ for charge storage. The capacitor may be tied to ground or V_{CC} . With multiple devices, the V^+ and V^- pins may share a common capacitor. For large numbers of devices, increasing the size of the shared common storage capacitors is recommended to reduce ripple.

V⁻: Negative Supply Output (RS232 Drivers). $V^- \cong -(2V_{CC} - 2V)$. This pin requires an external capacitor $C = 0.1\mu\text{F}$ for charge storage.

C1⁺, C1⁻, C2⁺, C2⁻: Commutating Capacitor Inputs. These pins require two external capacitors $C = 0.1\mu\text{F}$: one from C1⁺ to C1⁻ and another from C2⁺ to C2⁻. To maintain

charge pump efficiency, the capacitor's effective series resistance should be less than 2Ω.

TR IN: RS232 Driver Input Pins. Inputs are TTL/CMOS compatible. The inputs of unused drivers can be left unconnected since 300k input pull-up resistors to V_{CC} are included on chip.

TR OUT: Driver Outputs at RS232 Voltage Levels. The driver outputs are protected against ESD to ±10kV for human body model discharges.

RX IN: Receiver Inputs. These pins can be forced to ±25V without damage. The receiver inputs are protected against ESD to ±10kV for human body model discharges. Each receiver provides 0.4V of hysteresis for noise immunity.

RX OUT: Receiver Outputs with TTL/CMOS Voltage Levels.

SWITCHING TIME WAVEFORMS

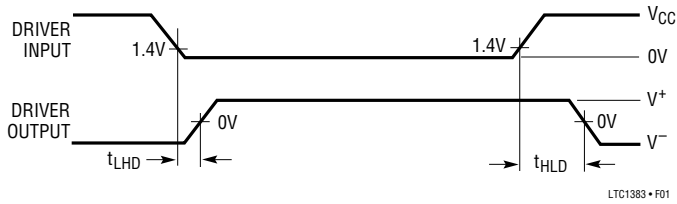

Figure 1. Driver Propagation Delay Timing

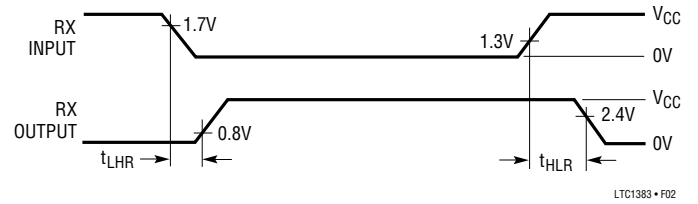
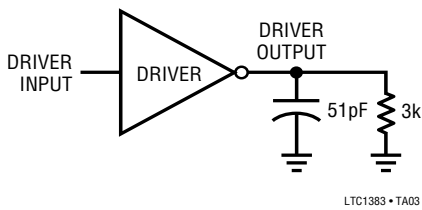

Figure 2. Receiver Propagation Delay Timing

TEST CIRCUITS

Driver Timing Test Load



Receiver Timing Test Load

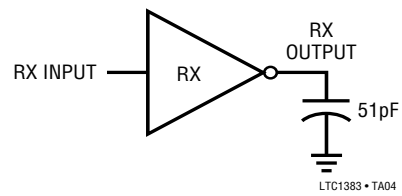

ESD Test Circuit

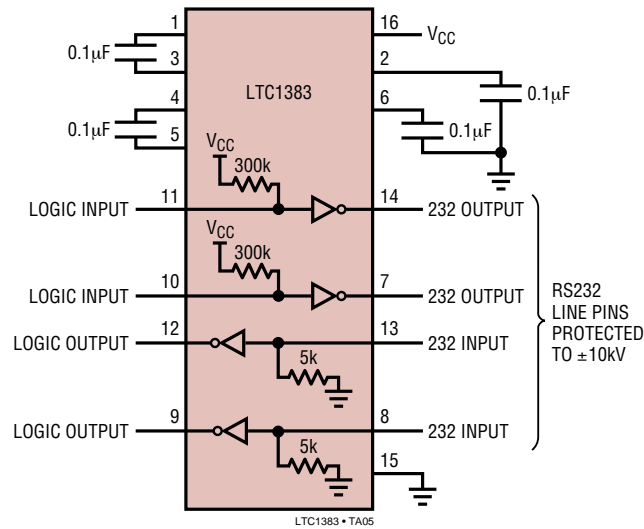

TYPICAL APPLICATIONS

**Paralleling Power Supply Generator
with Common Storage Capacitors**

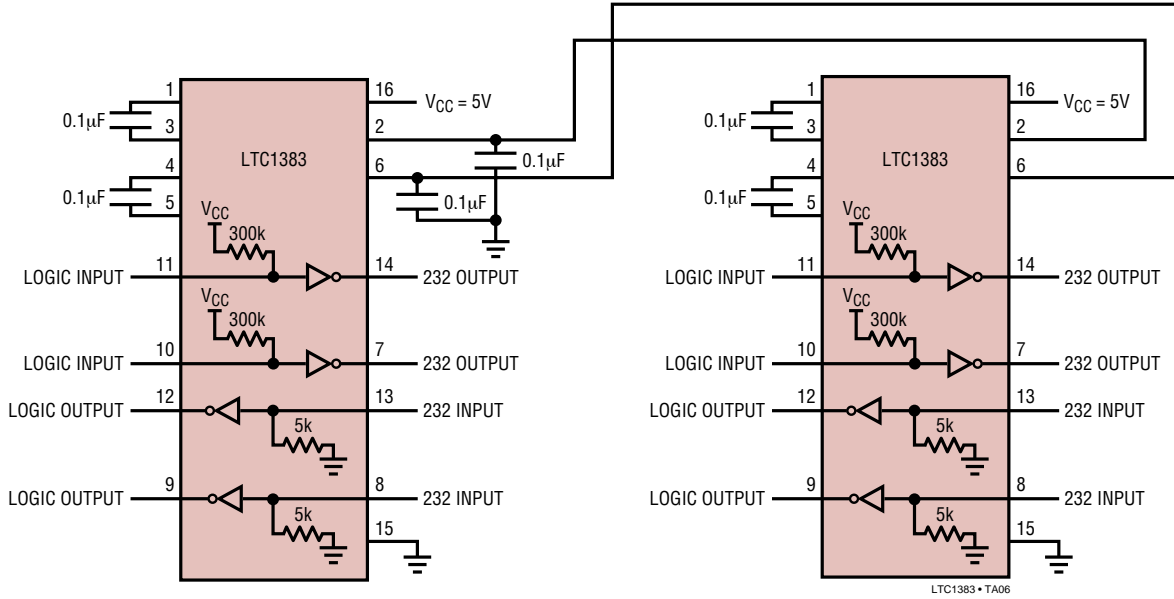

PACKAGE DESCRIPTION

N Package
16-Lead PDIP (Narrow .300 Inch)
 (Reference LTC DWG # 05-08-1510)

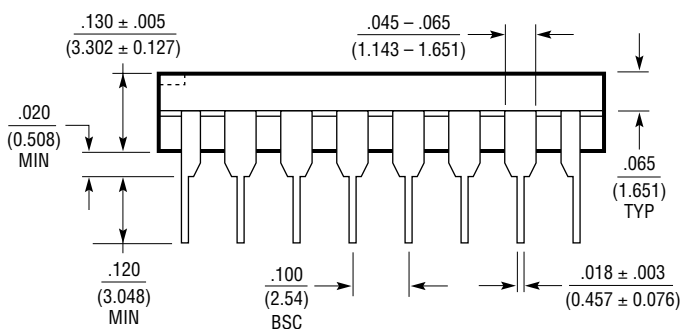
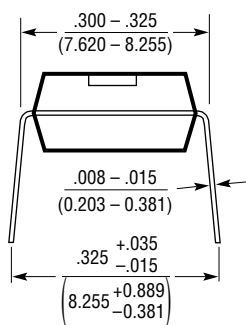
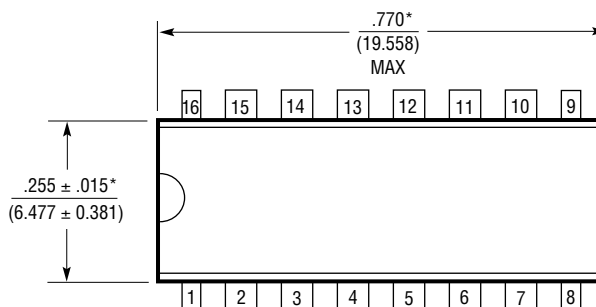

NOTE:
 1. DIMENSIONS ARE $\frac{\text{INCHES}}{\text{MILLIMETERS}}$

*THESE DIMENSIONS DO NOT INCLUDE MOLD FLASH OR PROTRUSIONS.
 MOLD FLASH OR PROTRUSIONS SHALL NOT EXCEED .010 INCH (0.254mm)

N16 1002

PACKAGE DESCRIPTION

S Package
16-Lead Plastic Small Outline (Narrow .150 Inch)
 (Reference LTC DWG # 05-08-1610)

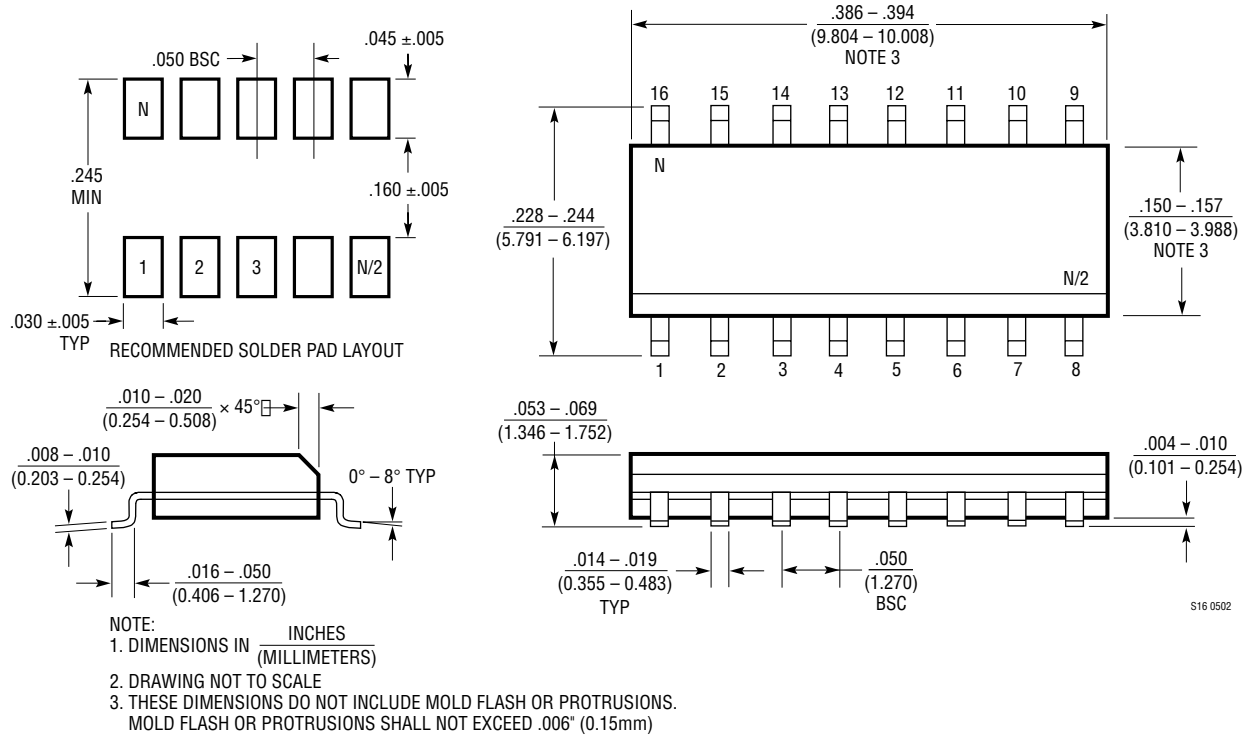

RELATED PARTS

PART NUMBER	DESCRIPTION	COMMENTS
LT1780/LT1781	5V, 2 Driver, 2 Receiver RS232 Transceivers	± 15 kV ESD per IEC 1000-4
LTC1382	5V, 2 Driver, 2 Receiver RS232 Transceiver	220 μ A Supply Current, 0.2 μ A in Shutdown
LTC1384	5V, 2 Driver, 2 Receiver RS232 Transceiver	220 μ A Supply Current, 2 Receivers Active in Shutdown
LTC1385	3.3V, 2 Driver, 2 Receiver RS562 Transceiver	220 μ A Supply Current, 2 Receivers Active in Shutdown
LTC1386	3.3V, 2 Driver, 2 Receiver RS562 Transceiver	220 μ A Supply Current, Narrow 16-pin SO

Looking for pricing, stock, or lifecycle information?

Click below to explore more details on WIN SOURCE:

 [View LTC1383IS#TRPBF on WIN SOURCE](#)

 [Linear Technology](#) Information

Optimize Your Supply Chain with WIN SOURCE Solutions

-  Global Sourcing Solution
-  Obsolete Management
-  Cost Control Management
-  Shortage Management
-  Alternative Solution
-  Excess Inventory Management