



**THE DATASHEET OF
LTC1323CSW#PBF**



ABSOLUTE MAXIMUM RATINGS

Supply Voltage (V_{CC}) 7V
 Input Voltage
 Logic Inputs $-0.3V$ to $V_{CC} + 0.3V$
 Receiver Inputs $\pm 15V$
 Driver Output Voltage (Forced) $\pm 15V$

Driver Short-Circuit Duration Indefinite
 Operating Temperature Range $0^{\circ}C$ to $70^{\circ}C$
 Storage Temperature Range $-65^{\circ}C$ to $150^{\circ}C$
 Lead Temperature (Soldering, 10 sec) $300^{\circ}C$

PACKAGE/ORDER INFORMATION

<p style="text-align: center;">TOP VIEW</p> <p style="text-align: center;">G PACKAGE 28-LEAD PLASTIC SSOP $T_{JMAX} = 150^{\circ}C, \theta_{JA} = 96^{\circ}C/W$</p>	<p style="text-align: center;">ORDER PART NUMBER</p> <p style="text-align: center;">LTC1323CG</p>	<p style="text-align: center;">TOP VIEW</p> <p style="text-align: center;">S PACKAGE 16-LEAD PLASTIC SO $T_{JMAX} = 125^{\circ}C, \theta_{JA} = 85^{\circ}C/W$</p>	<p style="text-align: center;">ORDER PART NUMBER</p> <p style="text-align: center;">LTC1323CS</p>
<p style="text-align: center;">TOP VIEW</p> <p style="text-align: center;">SW PACKAGE 24-LEAD PLASTIC SO WIDE $T_{JMAX} = 125^{\circ}C, \theta_{JA} = 85^{\circ}C/W$</p>	<p style="text-align: center;">ORDER PART NUMBER</p> <p style="text-align: center;">LTC1323CSW</p>		

Consult factory for Industrial and Military grade parts.

ELECTRICAL CHARACTERISTICS $V_{CC} = 5V \pm 10\%$, $T_A = 0^\circ C$ to $70^\circ C$ (Notes 2, 3)

SYMBOL	PARAMETER	CONDITIONS	MIN	TYP	MAX	UNITS	
Supplies							
I_{CC}	Normal Operation Supply Current	No Load, SHDN = 0V, $\overline{CPEN} = 0V$, $\overline{TXDEN} = 0V$, $\overline{RXEN} = 0V$	●	2.4	4	mA	
	Receiver Keep-Alive Supply Current	No Load, SHDN = 0V, $\overline{CPEN} = V_{CC}$, $\overline{TXDEN} = 0V$, $\overline{RXEN} = 0V$	●	65	100	μA	
	Shutdown Supply Current	No Load, SHDN = V_{CC} , $\overline{CPEN} = X$, $\overline{TXDEN} = X$, $\overline{RXEN} = 0V$	●	0.5	10	μA	
V_{EE}	Negative Supply Output Voltage	$I_{LOAD} \leq 10mA$ (Note 4), $V_{CC} = 5V$, $R_L = 100\Omega$ (Figure 1), $TXI = V_{CC}$, $R_{TXO} = 3k$ (Figure 5)	●	-5.5	-5	-4.5	V
f_{OSC}	Charge Pump Oscillator Frequency			200		kHz	
Differential Driver							
V_{OD}	Differential Output Voltage	No Load $R_L = 100\Omega$ (Figure 1)	● ●	± 8 ± 2		V	
ΔV_{OD}	Change in Magnitude of Differential Output Voltage	$R_L = 100\Omega$ (Figure 1)		0.2		V	
Differential Driver							
V_{OC}	Differential Common-Mode Output Voltage	$R_L = 100\Omega$		3		V	
V_{OS}	Single-Ended Output Voltage	No Load $R_L = 3k$ to GND	●	± 4.0		V	
			●	± 3.7		V	
V_{CMR}	Common-Mode Range	SHDN = V_{CC} or $\overline{CPEN} = V_{CC}$ or Power Off	●		± 10	V	
I_{SS}	Short-Circuit Current	$-5V \leq V_O \leq 5V$	●	35	120	500	mA
I_{OZ}	Three-State Output Current	SHDN = V_{CC} or $\overline{CPEN} = V_{CC}$ or Power Off, $-10V \leq V_O \leq 10V$	●		± 2	± 200	μA
Single-Ended Driver (Note 5)							
V_{OS}	Single-Ended Output Voltage	No Load $R_L = 3k$ to GND	●	± 4.5		V	
			●	± 3.7		V	
V_{CMR}	Common-Mode Range	SHDN = V_{CC} or $\overline{CPEN} = V_{CC}$ or $\overline{TXDEN} = V_{CC}$ or Power Off	●		± 10	V	
I_{SS}	Short-Circuit Current	$-5V \leq V_O \leq 5V$	●	35	220	500	mA
I_{OZ}	Three-State Output Current	SHDN = V_{CC} or $\overline{CPEN} = V_{CC}$ or $\overline{TXDEN} = V_{CC}$ or Power Off, $-10V \leq V_O \leq 10V$	●		± 2	± 200	μA
Receivers							
R_{IN}	Input Resistance	$-7V \leq V_{IN} \leq 7V$	●	12		k Ω	
	Differential Receiver Threshold Voltage	$-7V \leq V_{CM} \leq 7V$	●	-200	200	mV	
	Differential Receiver Input Hysteresis	$-7V \leq V_{CM} \leq 7V$	●		70	mV	
	Single-Ended Input, Low Voltage	(Note 5)	●		0.8	V	
	Single-Ended Input, High Voltage	(Note 5)	●	2		V	
V_{OH}	Output High Voltage	$I_O = -4mA$	●	3.5		V	
V_{OL}	Output Low Voltage	$I_O = 4mA$	●		0.4	V	
I_{SS}	Output Short-Circuit Current	$-5V \leq V_O \leq 5V$	●	7	85	mA	
I_{OZ}	Output Three-State Current	$-5V \leq V_O \leq 5V$, $\overline{RXEN} = V_{CC}$	●		± 2	± 100	μA

ELECTRICAL CHARACTERISTICS $V_{CC} = 5V \pm 10\%$, $T_A = 0^\circ\text{C}$ to 70°C (Notes 2 and 3)

SYMBOL	PARAMETER	CONDITIONS		MIN	TYP	MAX	UNITS
Logic Inputs							
V_{IH}	Input High Voltage	All Logic Input Pins	●	2.0			V
V_{IL}	Input Low Voltage	All Logic Input Pins	●			0.8	V
I_C	Input Current	All Logic Input Pins	●		± 1.0	± 20	μA
Switching Characteristics							
t_{PLH}, t_{PHL}	Differential Driver Propagation Delay	$R_L = 100\Omega, C_L = 100\text{pF}$ (Figures 2, 7)	●		40	120	ns
	Differential Driver Propagation Delay with Single-Ended Load	$R_L = 3k, C_L = 100\text{pF}$ (Figures 3, 9)	●		120	180	ns
	Single-Ended Driver Propagation Delay	$R_L = 3k, C_L = 100\text{pF}$, (Figures 5, 10) (Note 5)	●		40	120	ns
	Differential Receiver Propagation Delay	$C_L = 15\text{pF}$ (Figures 2, 11)	●		70	160	ns
	Single-Ended Receiver Propagation Delay	$C_L = 15\text{pF}$ (Figures 6, 12) (Note 5)	●		70	160	ns
	Inverting Receiver Propagation Delay in Keep-Alive Mode, $\text{SHDN} = 0V, \text{CPEN} = V_{CC}$	$C_L = 15\text{pF}$ (Figures 6, 12) (Note 5)	●		150	600	ns
t_{SKEW}	Differential Driver Output to Output	$R_L = 100\Omega, C_L = 100\text{pF}$ (Figures 2, 7)	●		10	50	ns
t_r, t_f	Differential Driver Rise/Fall Time	$R_L = 100\Omega, C_L = 100\text{pF}$ (Figures 2, 7)	●		50	150	ns
	Differential Driver Rise/Fall Time with Single-Ended Load	$R_L = 3k, C_L = 100\text{pF}$ (Figures 3, 9)	●		50	150	ns
	Single-Ended Driver Rise/Fall Time	$R_L = 3k, C_L = 100\text{pF}$ (Figures 5, 10) (Note 5)	●		15	80	ns
t_{HDIS}, t_{LDIS}	Differential Driver Output Active to Disable	$C_L = 15\text{pF}$ (Figures 4, 8)	●		180	250	ns
	Any Receiver Output Active to Disable	$C_L = 15\text{pF}$ (Figures 4, 13)	●		30	100	ns
t_{ENH}, t_{ENL}	Differential Driver Enable to Output Active	$C_L = 15\text{pF}$ (Figures 4, 8)	●		180	250	ns
	Any Receiver, Enable to Output Active	$C_L = 15\text{pF}$ (Figures 4, 13)	●		30	100	ns
V_{EER}	Supply Rise Time from Shutdown or Receiver Keep-Alive	$C1 = C2 = 0.33\mu\text{F}, C_{VEE} = 1\mu\text{F}$	●		0.2		ms

The ● denotes specifications which apply over the full operating temperature range.

Note 1: Absolute maximum ratings are those values beyond which the life of a device may be impaired.

Note 2: All currents into device pins are positive; all currents out of device pins are negative. All voltages are referenced to ground unless otherwise specified.

Note 3: All typicals are given at $V_{CC} = 5V, T_A = 25^\circ\text{C}$.

Note 4: I_{LOAD} is an external current being sunk into the V_{EE} pin.

Note 5: These specifications apply to the 24-pin SO Wide package only.

TYPICAL PERFORMANCE CHARACTERISTICS

Charge Pump Output Voltage vs Load Current

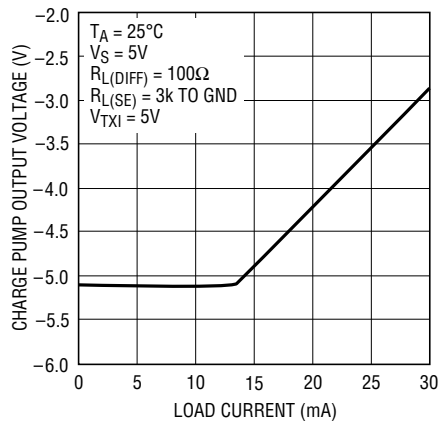

LTC1323 • TPC01

Differential Driver Swing vs Load Resistance

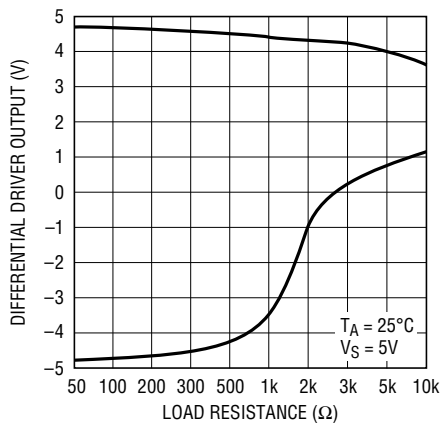

LTC1323 • TPC02

Single-Ended Driver Swing vs Load Resistance

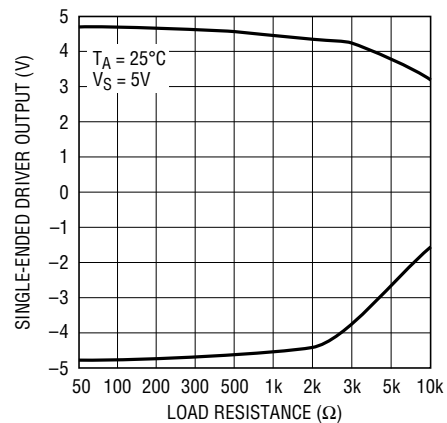

LTC1323 • TPC03

Supply Current vs Temperature

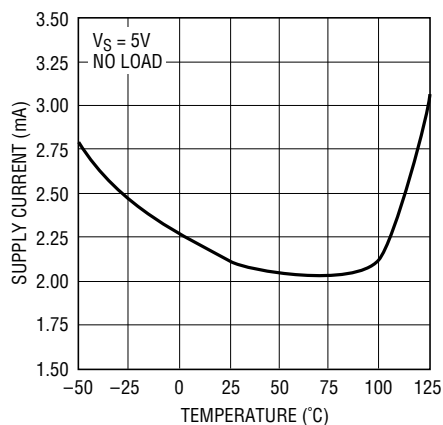

LTC1323 • TPC04

Differential Driver Swing vs Temperature

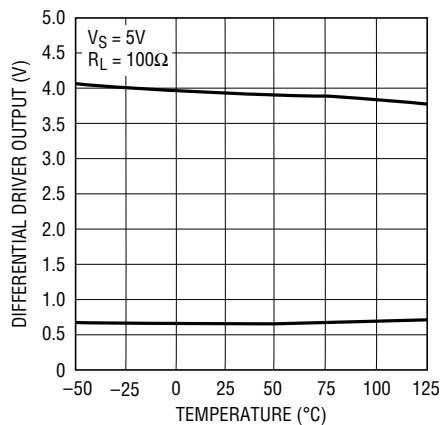

LTC1323 • TPC05

Single-Ended Driver Swing vs Temperature

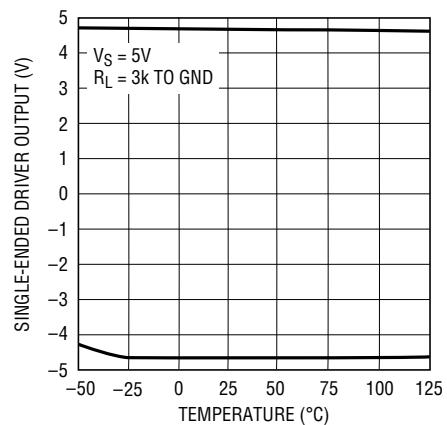

LTC1323 • TPC06

PIN FUNCTIONS

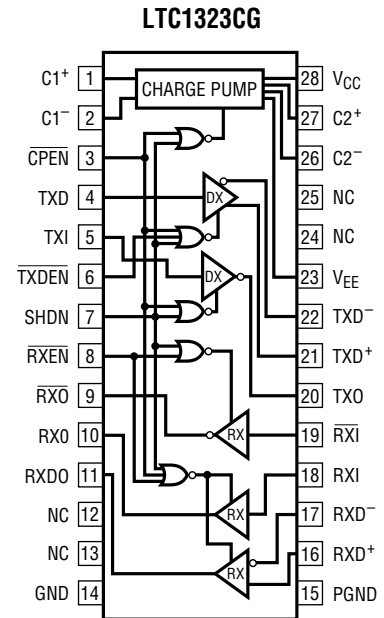
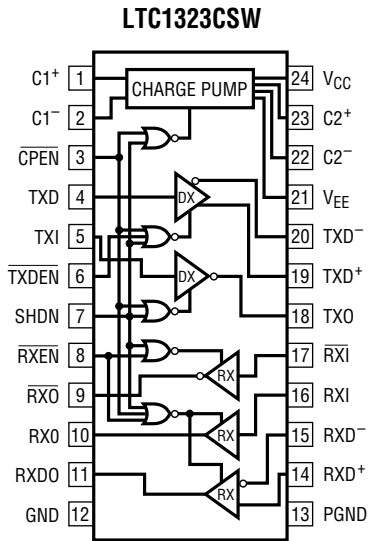
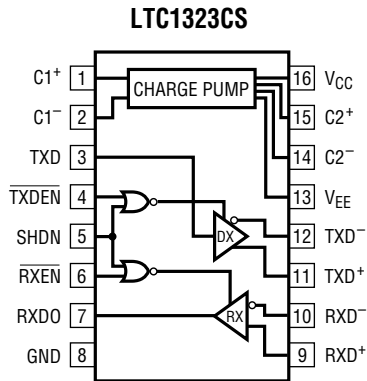

C1+: C1 Positive Input. Connect a 0.33 μ F capacitor between C1+ and C1-.

C1-: C1 Negative Input. Connect a 0.33 μ F capacitor between C1+ and C1-.

CPEN: TTL Level Charge Pump Enable Input. With CPEN held low, the charge pump is enabled and the chip operates normally. When CPEN is pulled high, the charge pump is disabled as well as both drivers, the noninverting single-ended receiver, and the differential receiver. The inverting single-ended receiver (RXI) is kept alive to monitor the control line and I_{CC} drops to 65 μ A. To turn off the receiver and drop I_{CC} to 0.5 μ A, pull the SHDN pin high.

TXD: Differential Driver Input (TTL compatible).

TXI: Single-Ended Driver Input (TTL compatible).

TXDEN: Differential Driver Output Enable (TTL compatible). A high level on this pin forces the differential driver into three-state; a low level enables the driver. This input does not affect the single-ended driver.

SHDN: Shutdown Input (TTL compatible). When this pin is high, the chip is shut down. All driver and receiver outputs are three-state, the charge pump turns off, and the supply current drops to 0.5 μ A. A low level on this pin allows normal operation.

RXEN: Receiver Enable (TTL compatible). A high level on this pin disables the receivers and three-states the logic outputs; a low level allows normal operation.

RXO: Inverting Single-Ended Receiver Output. Remains active in the receiver keep-alive mode.

RXO: Noninverting Single-Ended Receiver Output.

RXDO: Differential Receiver Output.

GND: Signal Ground. Connect to PGND with 24-pin package.

PGND: Power ground is connected internally to the charge pump and differential driver. Connect to the GND pin.

RXD+: Differential Receiver Noninverting Input. When this pin is ≥ 200 mV above RXD-, RXDO will be high; when this pin is ≥ 200 mV below RXD-, RXDO will be low.

RXD-: Differential Receiver Inverting Input.

RXI: Noninverting Receiver Input. This input controls the RXO output.

RXI: Inverting Receiver Input. This input controls the RXO output. In receiver keep-alive mode (CPEN high, SHDN low), this receiver can be used to monitor a wake-up control signal.

PIN FUNCTIONS

TXO: Single-Ended Driver Output.

TXD⁺: Differential Driver Noninverting Output.

TXD⁻: Differential Driver Inverting Output.

V_{EE}: Negative Supply Charge Pump Output. Requires a 1 μ F bypass capacitor to ground. If an external load is connected to the V_{EE} pin, the bypass capacitor value should be increased to 4.7 μ F.

C2⁻: C2 Negative Input. Connect a 0.33 μ F capacitor between C2⁺ and C2⁻.

C2⁺: C2 Positive Input. Connect a 0.33 μ F capacitor between C2⁺ and C2⁻.

V_{CC}: Positive Supply Input. 4.5V \leq V_{CC} \leq 5.5V. Requires a 1 μ F bypass capacitor to ground.

TEST CIRCUITS

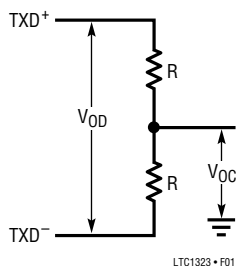

Figure 1

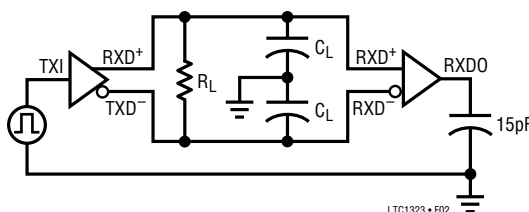

Figure 2

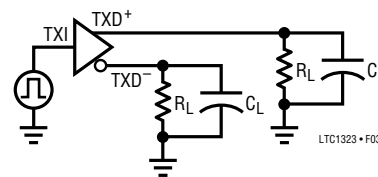

Figure 3

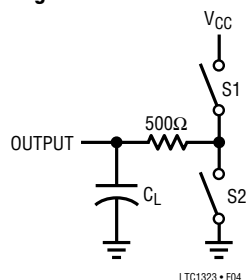

Figure 4

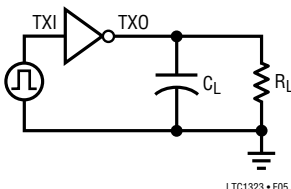

Figure 5

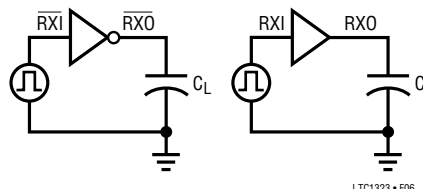

Figure 6

SWITCHING WAVEFORMS

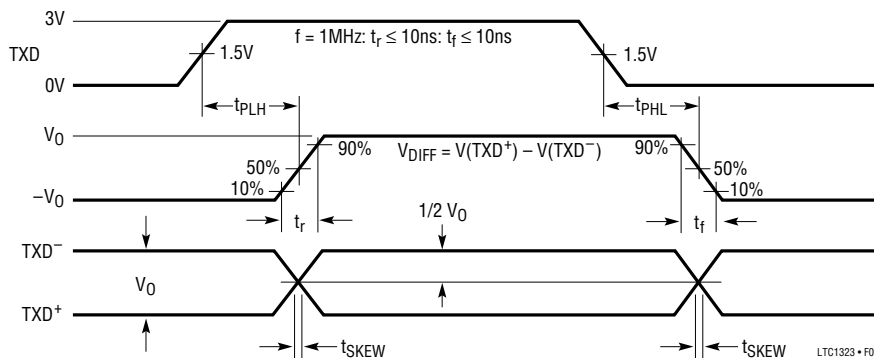

Figure 7. Differential Driver

SWITCHING WAVEFORMS

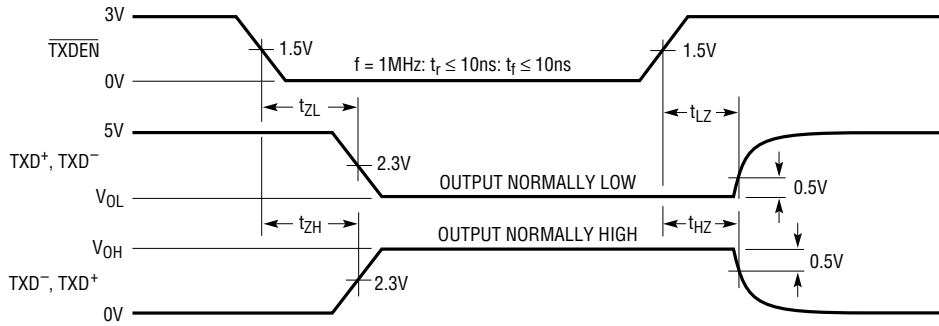

Figure 8. Differential Driver Enable and Disable

LTC1323 • F08

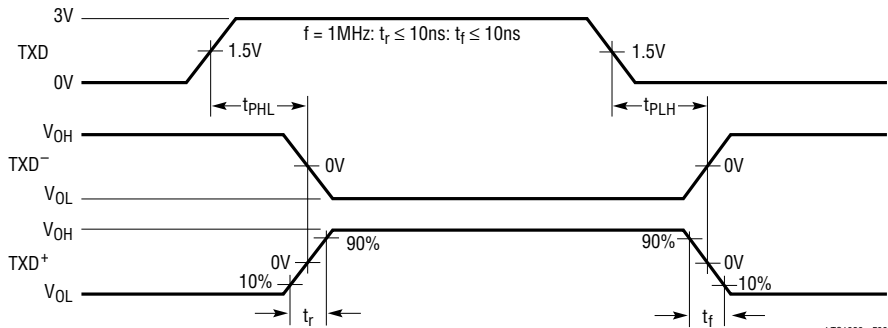

Figure 9. Differential Driver With Single-Ended Load

LTC1323 • F09

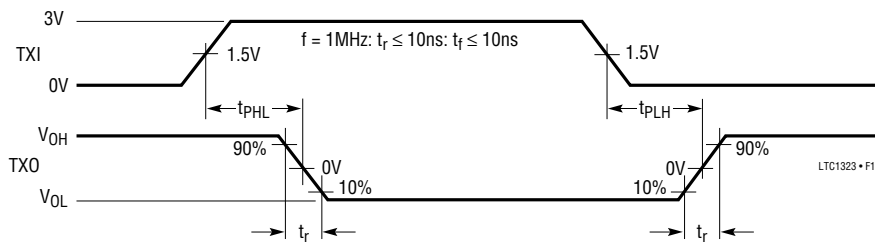

Figure 10. Single-Ended Driver

LTC1323 • F10

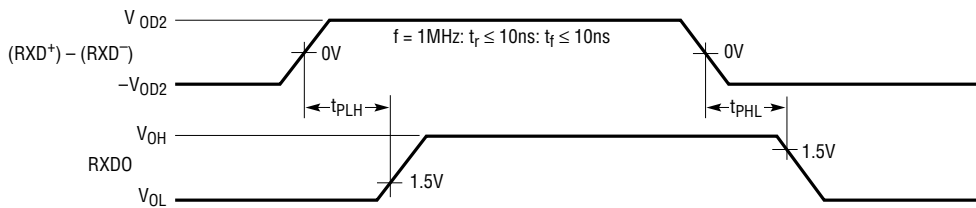

Figure 11. Differential Receiver

LTC1323 • F11

SWITCHING WAVEFORMS

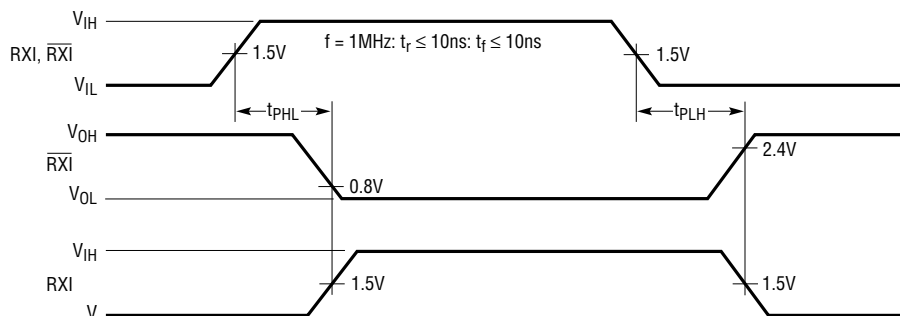

Figure 12. Single-Ended Receiver

LTC1323 • F12

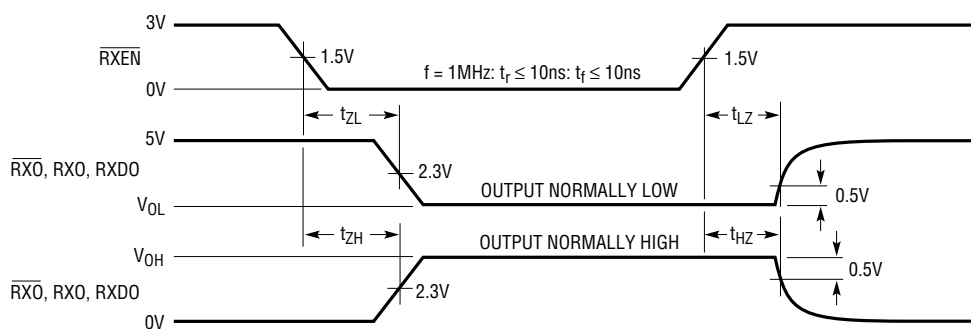

Figure 13. Receiver Enable and Disable

LTC1323 • F13

APPLICATIONS INFORMATION

Functional Description

The “serial port” on the back of an Apple-compatible computer or peripheral is a fairly versatile “multi-protocol” connector. It must be able to connect to a wide bandwidth LAN (an AppleTalk/LocalTalk network), which requires a high speed differential transceiver to meet the AppleTalk specification, and it must also be able to connect directly to a printer or modem through a short RS232 style link. The LTC1323 is designed to provide all the functions necessary to implement such a port on a single chip. Two versions of the LTC1323 are available: a 16-pin SO version which provides the minimum solution for interfacing to an AppleTalk network in a smaller package, and a larger 24-pin SO Wide version which additionally includes all the handshaking lines required to implement a complete AppleTalk/modem/printer serial port. All LTC1323s run from a single 5V power supply while providing true single-ended compatibility, and include a 0.5 μ A low power shutdown mode

to improve lifetime in battery-powered devices. The 24-pin SO Wide version also includes a receiver keep-alive mode for monitoring external signals while drawing 65 μ A typically.

The LTC1323 includes an RS422-compatible differential driver/receiver pair for data transmission, with the driver specified to drive 2V into the 100 Ω primary of a typical LocalTalk interface transformer/RFI interference network. Either output of the differential RS422 driver can also act as a single-ended driver, allowing the LTC1323 to communicate over a standard serial connection. The 24-pin SO Wide LTC1323 also includes an extra single ended only driver and two extra RS232-compatible single-ended receivers for handshaking lines. All versions include an on-board charge pump to provide a regulated -5 V supply required for the single-ended drivers. The charge pump can also provide up to 10mA of external load current to power other circuitry.

APPLICATIONS INFORMATION

Driving Differential AppleTalk or Single-Ended Loads

The differential driver is able to drive either an AppleTalk load or a single-ended load such as a printer or modem. With a differential AppleTalk load, TXD⁺ and TXD⁻ will typically swing between 1.2V and 3.5V (Figure 14a). With a single-ended 3k load such as a printer, either TXD⁺ or TXD⁻ will meet the single-ended voltage swing requirement of $\pm 3.7V$ (Figure 14b). An automatic switching circuit prevents the differential driver from overloading the charge pump if the outputs are shorted to ground while driving single-ended signals. This allows the second single-ended driver to continue to operate normally when the first is shorted, and allows external circuitry attached to the charge pump output to continue to operate even if there are faults at the driver outputs.

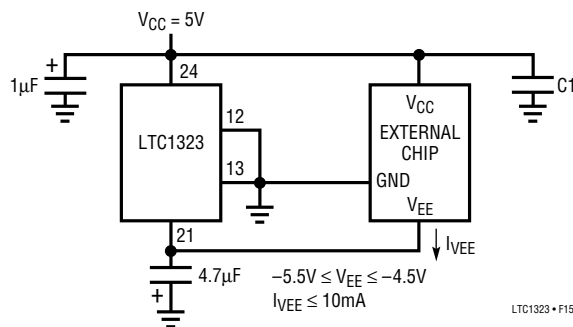

Figure 14

Thermal Shutdown Protection

The LTC1323 includes a thermal shutdown circuit which protects against prolonged shorts at the driver outputs. If a driver output is shorted to another output or to the power supply, the current will be initially limited to a maximum of 500mA. When the die temperature rises above 150°C, the thermal shutdown circuit disables the driver outputs. When the die cools to about 130°C, the outputs are re-enabled. If the short still exists, the part will heat again and the cycle will repeat. This oscillation occurs at about 10Hz and prevents the part from being damaged by excessive power dissipation. When the short is removed, the part will return to normal operation.

Power Shutdown

The power shutdown feature of the LTC1323 is designed for battery-powered systems. When SHDN is forced high the part enters shutdown mode. In shutdown the supply current typically drops from 2.4mA to 0.5µA, the charge pump turns off, and the driver and receiver outputs are three-stated.

Receiver Keep-Alive Mode (24-Pin SO Wide Only)

The 24-pin SO Wide version of the LTC1323 also features a power saving receiver keep-alive mode. When \overline{CPEN} is pulled high the charge pump is turned off and the outputs of both drivers, the noninverting single-ended receiver and the differential receiver are forced into three-state. The inverting single-ended receiver (RXI) is kept alive with I_{CC} dropping to 65µA and the receiver delay time increasing to a maximum of 400ns. The receiver can then be used to monitor a wake-up control signal.

Charge Pump Capacitors and Supply Bypassing

The LTC1323 requires two external 0.33µF capacitors for the charge pump to operate: one from C1⁺ to C1⁻ and one from C2⁺ to C2⁻. These capacitors should be low ESR types and should be mounted as close as possible to the LTC1323. Monolithic ceramic capacitors work well in this application. Do not use capacitors greater than 2µF at the charge pump pins or internal peak currents can rise to destructive levels. The LTC1323 also requires that both V_{CC} and V_{EE} be well bypassed to ensure proper charge pump operation and prevent data errors. A 1µF capacitor from V_{CC} to ground is adequate. A 1µF capacitor is required from V_{EE} to ground and should be increased to 4.7µF if an external load is connected to the V_{EE} pin. Ceramic or tantalum capacitors are adequate for power supply bypassing; aluminum electrolytic capacitors should only be used if their ESR is low enough for proper charge pump operation. Inadequate bypass or charge pump capacitors will cause the charge pump output to go out of regulation prematurely, degrading the output swing at the SINGLE-ENDED driver outputs.

APPLICATIONS INFORMATION

Driving an External Load from V_{EE}

An external load may be connected between ground and the V_{EE} pin as shown in Figure 15. The LTC1323 V_{EE} pin will sink up to a maximum of 10mA while maintaining the pin voltage between -4.5V and -5.5V. If an external load is connected, the V_{EE} bypass capacitor should be increased to 4.7μF. Both LTC1323 and the external chip should have separate V_{CC} bypass capacitors but can share the V_{EE} capacitor.

EMI Filter

Most LocalTalk applications use an electromagnetic interference (EMI) filter consisting of a resistor-capacitor T network between each driver and receiver and the connector. Unfortunately, the resistors significantly attenuate the drivers output signals before they reach the cable. Because

the LTC1323 uses a single supply differential driver, the resistor values should be reduced to 5Ω to 10Ω to guarantee adequate voltage swing on the cable (Figure 16a). In most applications, removing the resistors completely does not cause an increase in EMI as long as a shielded connector and cable are used (Figure 16b). With the resistors removed the only DC load is the primary resistance of the LocalTalk transformer. This will increase the DC standby current when the driver outputs are active, but does not adversely affect the drivers because they can handle a direct indefinite short circuits without damage. Transformer primary resistance should be above 15Ω to keep the LTC1323 operating normally and prevent it from entering thermal shutdown. For maximum swing and EMI immunity, a ferrite bead and capacitor T network can be used (Figure 16c).

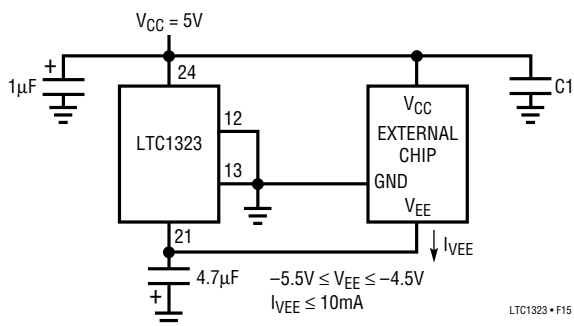

Figure 15

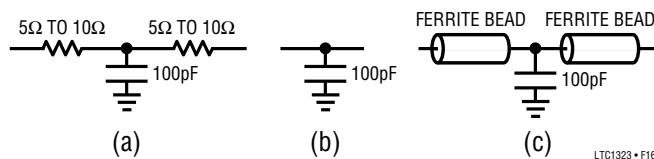
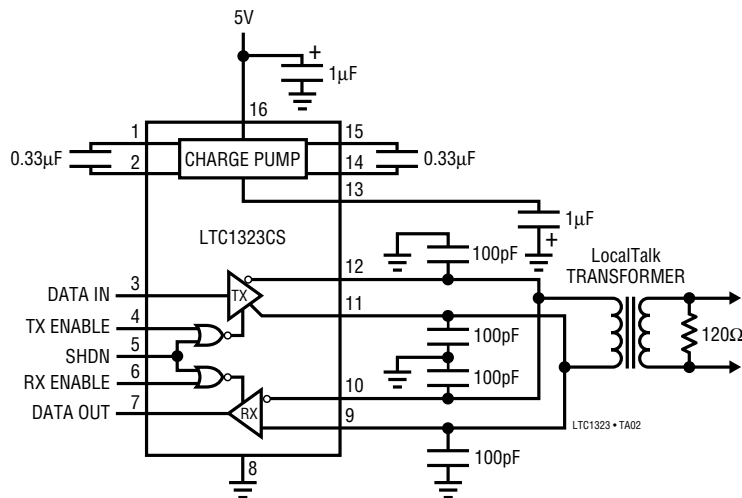

Figure 16. EMI Filters

TYPICAL APPLICATIONS

Typical LocalTalk Connection



PACKAGE DESCRIPTION Dimensions in inches (millimeters) unless otherwise noted.

G Package
28-Lead Plastic SSOP (0.209)
 (LTC DWG # 05-08-1640)

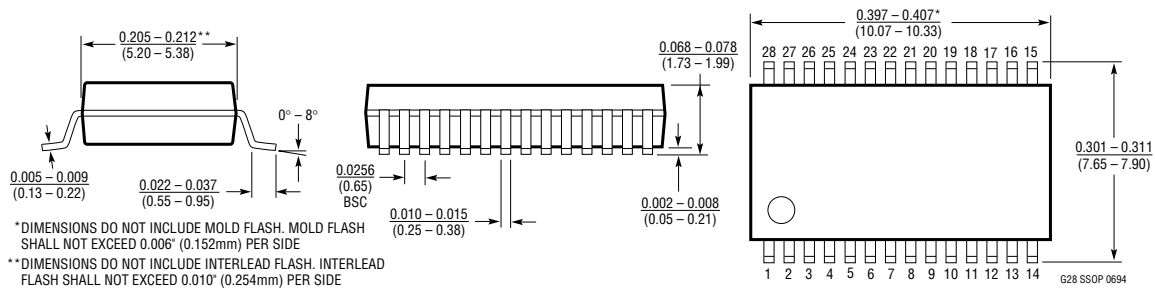

S Package
16-Lead Plastic Small Outline (Narrow 0.150)
 (LTC DWG # 05-08-1610)

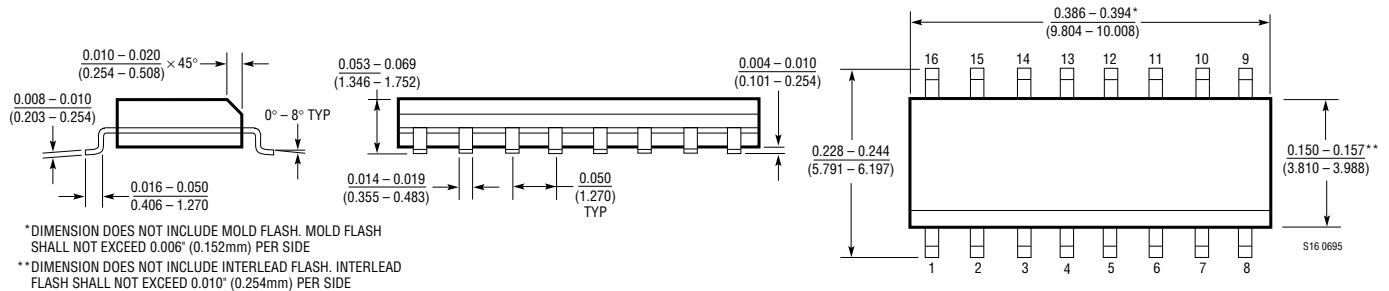

SW Package
24-Lead Plastic Small Outline (Wide 0.300)
 (LTC DWG # 05-08-1620)

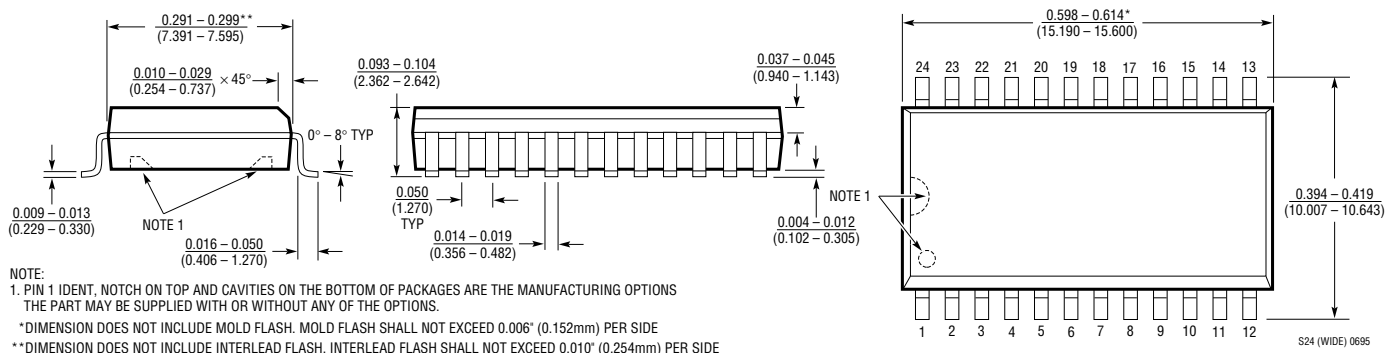

Looking for pricing, stock, or lifecycle information?

Click below to explore more details on WIN SOURCE:

 [View LTC1323CSW#PBF on WIN SOURCE](#)

 [Linear Technology](#) Information

Optimize Your Supply Chain with WIN SOURCE Solutions

-  Global Sourcing Solution
-  Obsolete Management
-  Cost Control Management
-  Shortage Management
-  Alternative Solution
-  Excess Inventory Management