



**THE DATASHEET OF
LTC1165CS8#PBF**



FEATURES

- Operates from 1.8V to 6V
- 0.01µA Standby Current
- 95µA Operating Current per Channel at 3.3V
- Fully Enhances N-Channel Switches
- No External Charge Pump Components
- Built-In Gate Voltage Clamps
- Easily Protected Against Supply Transients
- Controlled Switching ON and OFF Times
- Compatible with 5V, 3V and Sub-3V Logic Families
- Available in 8-Pin SOIC

APPLICATIONS

- PCMCIA Card 3.3V/5V Switch
- 2-Cell High-Side Load Switching
- Boost Regulator Shutdown to Zero Standby Current
- Replacing P-Channel Switches
- Notebook Computer Power Management
- Palmtop Computer Power Management
- Portable Medical Equipment
- Mixed 3.3V and 5V Supply Switching

DESCRIPTION

The LTC1163/LTC1165 triple low voltage MOSFET drivers make it possible to switch supply or ground referenced loads through inexpensive, low $R_{DS(ON)}$ N-channel switches from as little as a 1.8V supply. The LTC1165 has inverting inputs and makes it possible to directly replace P-channel MOSFET switches while maintaining system drive polarity. The LTC1163 has noninverting inputs.

Micropower operation, with 0.01µA standby current and 95µA operating current, coupled with a power supply range of 1.8V to 6V, make the LTC1163/LTC1165 ideally suited for 2- to 4-cell battery-powered applications. The LTC1163/LTC1165 are also well suited for sub-3V, 3.3V and 5V nominal supply applications.

The LTC1163/LTC1165 internal charge pumps boost the gate voltage 8V above a 3.3V rail, fully enhancing inexpensive N-channels for high- or low-side switch applications.

The LTC1163/LTC1165 are available in both an 8-pin DIP and an 8-pin SOIC.

TYPICAL APPLICATION

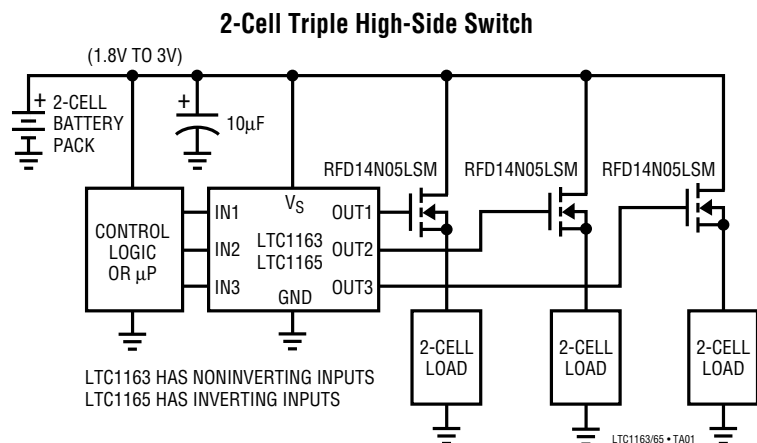

MOSFET Switch Gate Voltage

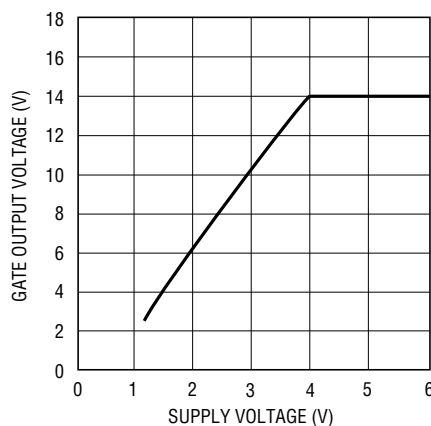

LTC1163/65 • TA02

LTC1163/LTC1165

ABSOLUTE MAXIMUM RATINGS

Supply Voltage	7V	Operating Temperature Range	
Any Input Voltage	7V to (GND – 0.3V)	LTC1163C/LTC1165C	0°C to 70°C
Any Output Voltage	20V to (GND – 0.3V)	Storage Temperature Range	–65°C to 150°C
Current (Any Pin)	50mA	Lead Temperature (Soldering, 10 sec)	300°C

PACKAGE/ORDER INFORMATION

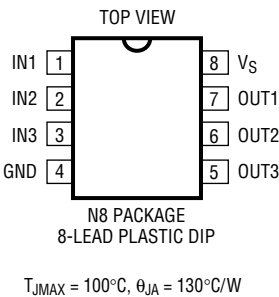
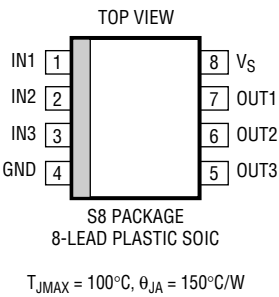
 <p>N8 PACKAGE 8-LEAD PLASTIC DIP</p> <p>$T_{JMAX} = 100^{\circ}C, \theta_{JA} = 130^{\circ}C/W$</p>	ORDER PART NUMBER	 <p>S8 PACKAGE 8-LEAD PLASTIC SOIC</p> <p>$T_{JMAX} = 100^{\circ}C, \theta_{JA} = 150^{\circ}C/W$</p>	ORDER PART NUMBER
	LTC1163CN8 LTC1165CN8		LTC1163CS8 LTC1165CS8
	S8 PART MARKING		
	1163 1165		

ELECTRICAL CHARACTERISTICS $V_S = 1.8V$ to $6V, T_A = 25^{\circ}C$, unless otherwise noted.

SYMBOL	PARAMETER	CONDITIONS	LTC1163C/LTC1165C			UNITS	
			MIN	TYP	MAX		
I_Q	Quiescent Current OFF	$V_S = 1.8V, V_{IN1} = V_{IN2} = V_{IN3} = V_{OFF}$ (Note 1,2)		0.01	1	μA	
		$V_S = 3.3V, V_{IN1} = V_{IN2} = V_{IN3} = V_{OFF}$ (Note 1,2)		0.01	1	μA	
		$V_S = 5V, V_{IN1} = V_{IN2} = V_{IN3} = V_{OFF}$ (Note 1,2)		0.01	1	μA	
	Quiescent Current ON	$V_S = 1.8V, V_{IN} = V_{ON}$ (Note 2,3)		60	120	μA	
		$V_S = 3.3V, V_{IN} = V_{ON}$ (Note 2,3)		95	200	μA	
		$V_S = 5V, V_{IN} = V_{ON}$ (Note 2,3)		180	400	μA	
V_{INH}	Input High Voltage	$1.8V < V_S < 2.7V$	●	$80\% \times V_S$		V	
		$2.7V < V_S < 6V$	●	$70\% \times V_S$		V	
V_{INL}	Input Low Voltage	$1.8V < V_S < 6V$	●	$15\% \times V_S$		V	
I_{IN}	Input Current	$0V \leq V_{IN} \leq V_S$	●	± 1		μA	
C_{IN}	Input Capacitance			5		pF	
$V_{GATE} - V_S$	Gate Voltage Above Supply	$V_S = 1.8V, V_{IN} = V_{ON}$ (Note 2)	●	3.5	4.1	6.0	V
		$V_S = 2V, V_{IN} = V_{ON}$ (Note 2)	●	4.0	4.6	7.0	V
		$V_S = 2.2V, V_{IN} = V_{ON}$ (Note 2)	●	4.5	5.2	8.0	V
		$V_S = 3.3V, V_{IN} = V_{ON}$ (Note 2)	●	6.0	8.0	9.5	V
		$V_S = 5V, V_{IN} = V_{ON}$ (Note 2)	●	5.0	9.0	13.0	V
t_{ON}	Turn-ON Time	$V_S = 3.3V, C_{GATE} = 1000pF$ Time for $V_{GATE} > V_S + 1V$ Time for $V_{GATE} > V_S + 2V$		40	120	400	μs
				60	180	600	μs
		$V_S = 5V, C_{GATE} = 1000pF$ Time for $V_{GATE} > V_S + 1V$ Time for $V_{GATE} > V_S + 2V$		30	95	300	μs
				40	130	400	μs

ELECTRICAL CHARACTERISTICS $V_S = 1.8V$ to $6V$, $T_A = 25^\circ C$, unless otherwise noted.

SYMBOL	PARAMETER	CONDITIONS	LTC1163C/LTC1165C			UNITS
			MIN	TYP	MAX	
t_{OFF}	Turn-OFF Time	$V_S = 3.3V$, $C_{GATE} = 1000pF$ Time for $V_{GATE} < 0.5V$	20	65	200	μs
		$V_S = 5V$, $C_{GATE} = 1000pF$ Time for $V_{GATE} < 0.5V$	15	45	150	μs

The ● denotes specifications which apply over the full operating temperature range.

Note 1: Quiescent current OFF is for all channels in OFF condition.

Note 2: LTC1163: $V_{OFF} = 0V$, $V_{ON} = V_S$. LTC1165: $V_{OFF} = V_S$, $V_{ON} = 0V$

Note 3: Quiescent current ON is per driver and is measured independently.

TYPICAL PERFORMANCE CHARACTERISTICS

Standby Supply Current

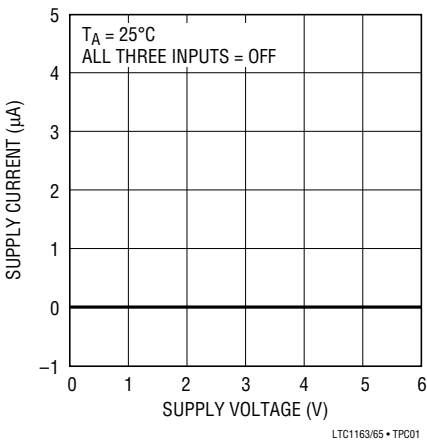

Supply Current per Driver ON

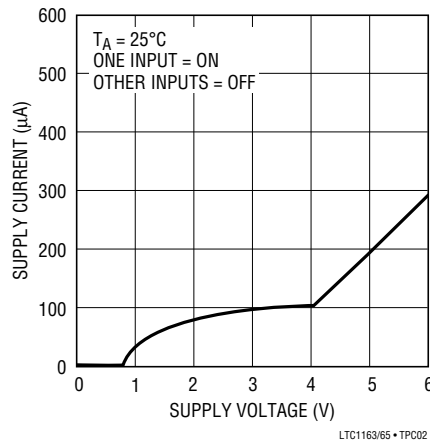

Gate Voltage Above Supply

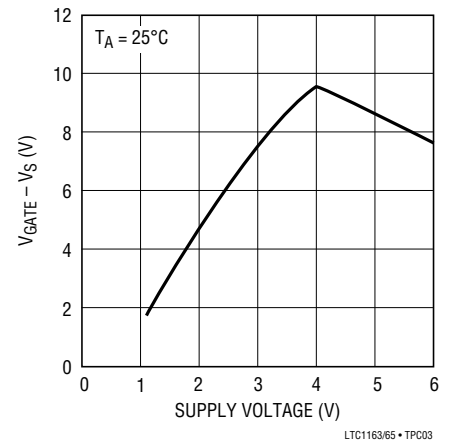

Input Threshold Voltage

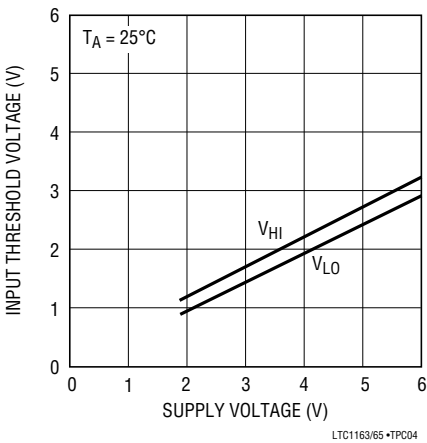

Turn-ON Time

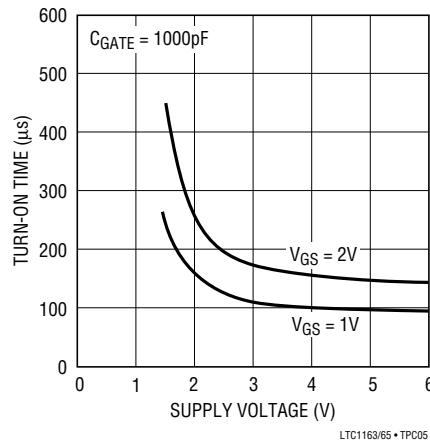

Turn-OFF Time

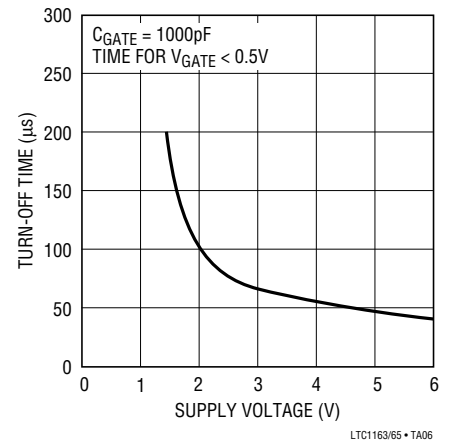

TYPICAL PERFORMANCE CHARACTERISTICS

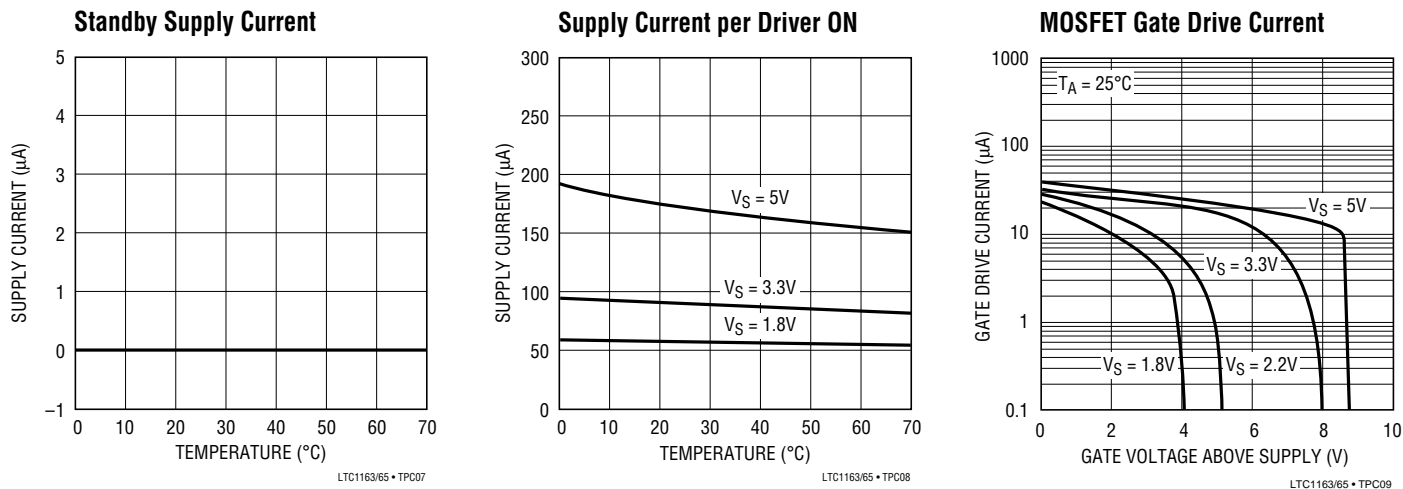

PIN FUNCTIONS

Input Pins

The LTC1163 is noninverting; i.e., the MOSFET gate is driven above the supply when the input pin is held high. The LTC1165 is inverting and drives the MOSFET gate high when the input pin is held low. The inverting inputs of the LTC1165 allow P-channel switches to be replaced by lower resistance/cost N-channel switches while maintaining system drive polarity.

The LTC1163/LTC1165 logic inputs are high impedance CMOS gates with ESD protection diodes to ground and therefore should not be forced below ground. The inputs can however, be driven above the power supply rail as there are no clamping diodes connected between the input pins and supply pin. This facilitates operation in mixed 5V/3V systems.

Output Pins

The output pin is either driven to ground when the switch is turned OFF or driven above the supply rail when the switch is turned ON. The output is clamped to about 14V above ground by a built-in Zener clamp. This pin has a relatively high impedance when driven above the rail (the equivalent of a few hundred $\text{k}\Omega$). Care should be taken to minimize any loading of this pin by parasitic resistance to ground or supply.

Supply Pin

A 150 Ω resistor should be inserted in series with the ground pin or supply pin if negative supply voltage transients are anticipated. This will limit the current flowing from the power source into the LTC1163/LTC1165 to tens of milliamps during reverse battery conditions.

OPERATION

The LTC1163/LTC1165 are triple micropower MOSFET drivers designed for operation over the 1.8V to 6V supply range and include the following functional blocks:

3V Logic Compatible Inputs

The LTC1163/LTC1165 inputs have been designed to accommodate a wide range of 3V and 5V logic families.

The input threshold voltage is set at roughly 50% of the supply voltage and approximately 200mV of input hysteresis is provided to ensure clean switching.

The input enables all of the following circuit blocks: the bias generator, the high frequency oscillator and gate charge pump. Therefore, when the input is turned off, the entire circuit powers down and the supply current drops below 1 μA .

OPERATION

Gate Charge Pump

Gate drive for the power MOSFET is produced by an internal charge pump circuit which generates a gate voltage substantially higher than the power supply voltage. The charge pump capacitors are included on chip and therefore no external components are required to generate gate drive.

Controlled Gate Rise and Fall Times

When the input is switched ON and OFF, the gate is charged by the internal charge pump and discharged in a controlled manner. The charge and discharge rates have been set to minimize RFI and EMI emissions.

BLOCK DIAGRAM (One Channel)

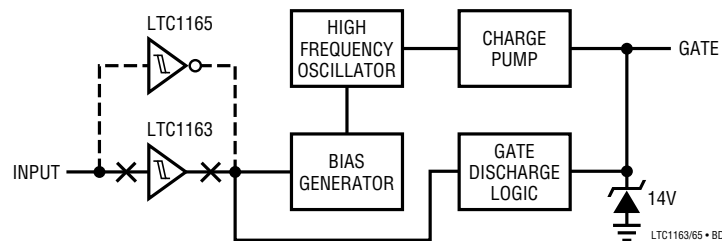

APPLICATIONS INFORMATION

Logic-Level MOSFET Switches

The LTC1163/LTC1165 are designed to operate with logic-level N-channel MOSFET switches. Although there is some variation among manufacturers, logic-level MOSFET switches are typically rated with $V_{GS} = 4V$ with a maximum continuous V_{GS} rating of $\pm 10V$. $R_{DS(ON)}$ and maximum V_{DS} ratings are similar to standard MOSFETs and there is generally little price differential. Logic-level MOSFETs are frequently designated by an “L” and are usually available in surface mount packaging. Some logic-level MOSFETs are rated with V_{GS} up to $\pm 15V$ and can be used in applications which require operation over the entire 1.8V to 6V range.

Powering Large Capacitive Loads

Electrical subsystems in portable battery-powered equipment are typically bypassed with large filter capacitors to reduce supply transients and supply induced glitching. If not properly powered however, these capacitors may themselves become the source of supply glitching.

For example, if a $100\mu F$ capacitor is powered through a switch with a slew rate of $0.1V/\mu s$, the current during start-up is:

$$\begin{aligned} I_{START} &= C(\Delta V/\Delta t) \\ &= (100 \times 10^{-6})(1 \times 10^5) \\ &= 10A \end{aligned}$$

Obviously, this is too much current for the regulator (or output capacitor) to supply and the output will glitch by as much as a few volts.

The startup current can be substantially reduced by limiting the slew rate at the gate of an N-channel as shown in Figure 1. The gate drive output of the LTC1163/LTC1165 is passed through a simple RC network, R1 and C1, which substantially slows the slew rate of the MOSFET gate to approximately $1.5 \times 10^{-4}V/\mu s$. Since the MOSFET is operating as a source follower, the slew rate at the source is essentially the same as that at the gate, reducing the startup current to approximately 15mA which is easily

APPLICATIONS INFORMATION

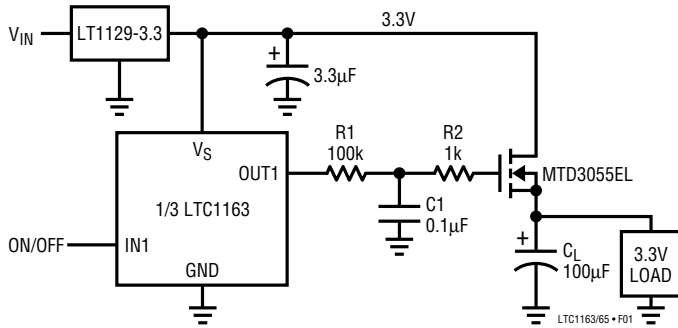

Figure 1. Powering a Large Capacitive Load

managed by the system regulator. R2 is required to eliminate the possibility of parasitic MOSFET oscillations during switch transitions. It is a good practice to isolate the gates of paralleled MOSFETs with 1k resistors to decrease the possibility of interaction between switches.

Mixed 5V/3V Systems

Because the input ESD protection diodes are referenced to ground instead of the supply pin, it is possible to drive the LTC1163/LTC1165 inputs from 5V CMOS or TTL logic even though the LTC1163/LTC1165 are powered from a 3.3V supply as shown in Figure 2. The input threshold voltage is approximately 50% of the supply voltage or 1.6V

on a 3.3V supply which is compatible with 5V TTL and CMOS logic. (The LTC1163/LTC1165 cannot however, be driven by 3V logic when powered from a 5V supply because the threshold is approximately 2.5V.)

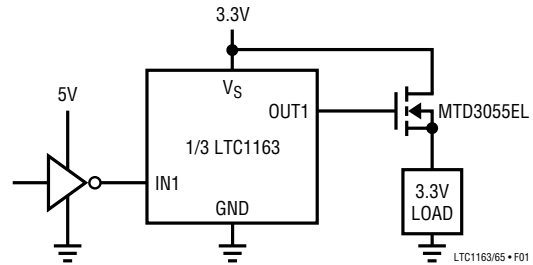

Figure 2. Direct Interface to 5V Logic

Reverse Battery Protection

The LTC1163/LTC1165 can be protected against reverse battery conditions by connecting a 150Ω resistor in series with the ground pin or supply pin. The resistor limits the supply current to less than 24mA with -3.6V applied. Because the LTC1163/LTC1165 draw very little current while in normal operation, the drop across the resistor is minimal. The 3.3V μ P (or control logic) can be protected by adding 10k resistors in series with the input pins.

TYPICAL APPLICATIONS

PCMCIA Card 3.3V/5V V_{CC} Switch

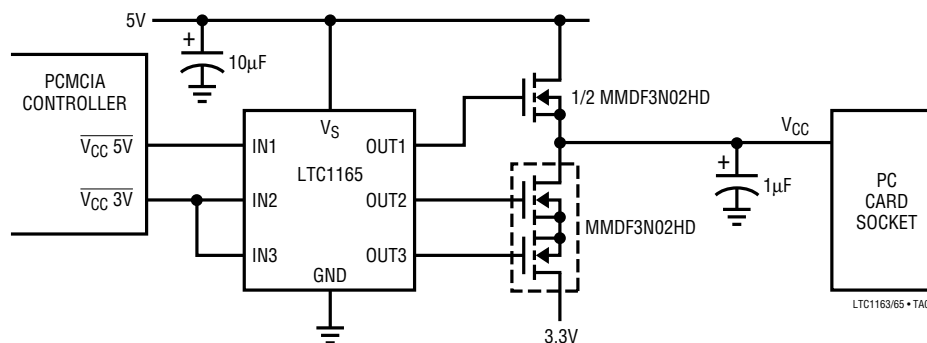

NOTE: USE LTC1163 WITH NONINVERTING PCMCIA CONTROLLERS

TYPICAL APPLICATIONS

2-Cell to 3.3V, 5V and 12V High-Side Switch/Converter with 0.01µA Standby Current

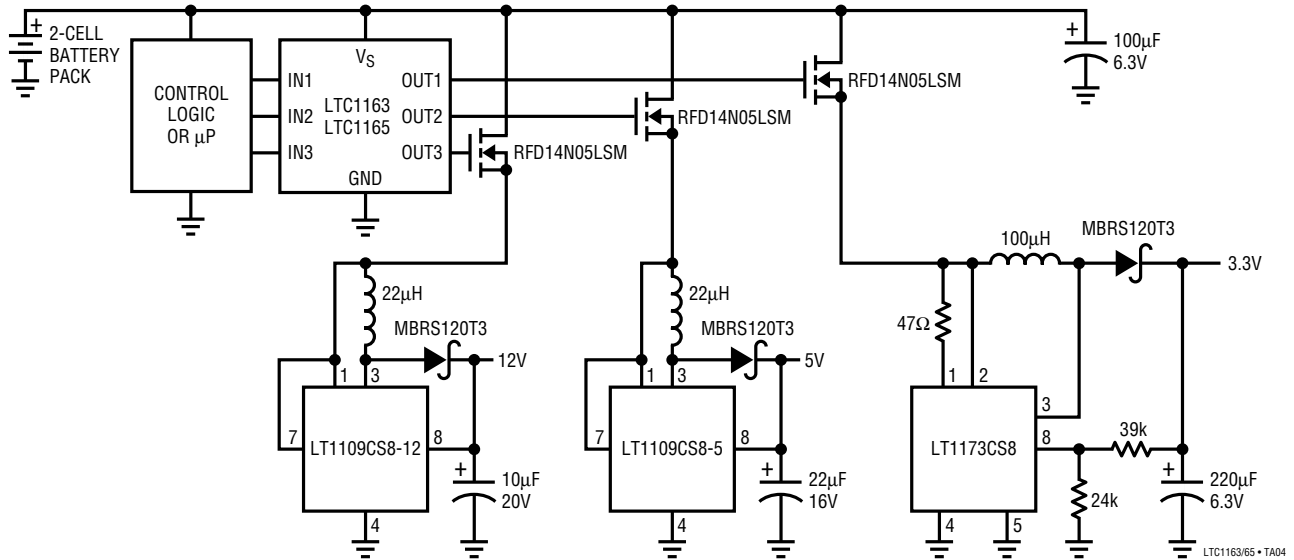

PCMCIA Card Socket V_{PP} Switch/Regulator

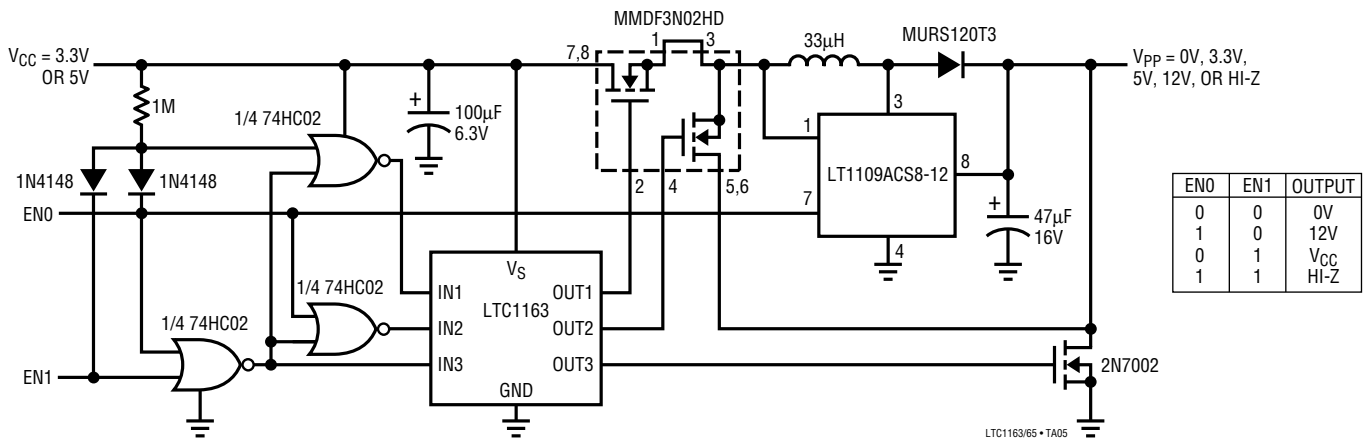

Ultra-Low Drop Triple 3.3V High-Side Switch

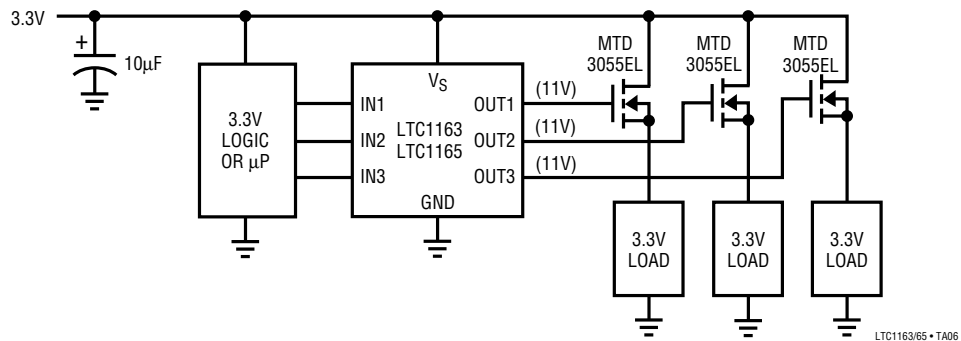

TYPICAL APPLICATIONS

Mixed Voltage High- and Low-Side Switches

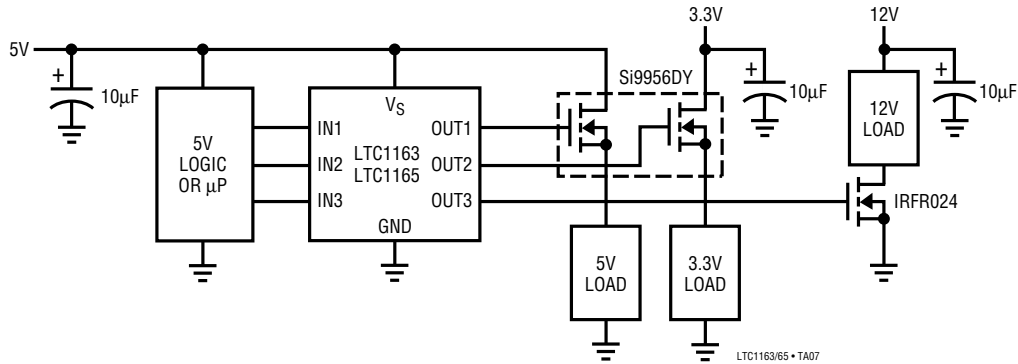

3-Cell to 3.3V Ultra-Low Drop Regulator with 2 Ramped Switches

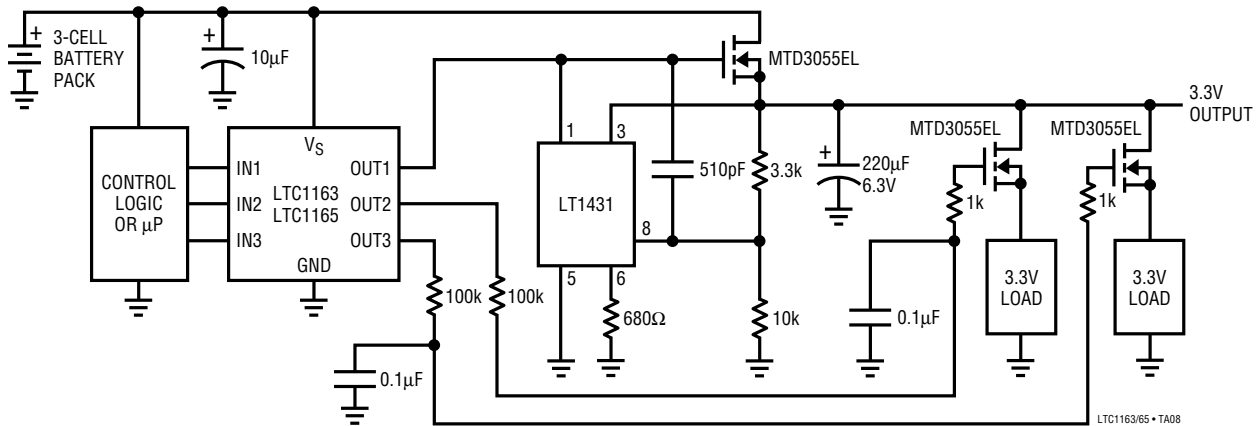

PACKAGE DESCRIPTION Dimensions in inches (millimeters) unless otherwise noted.

N8 Package
8-Lead
Plastic DIP

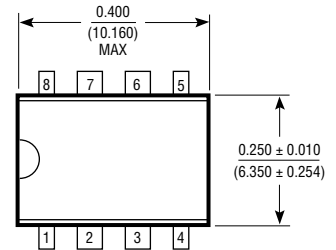
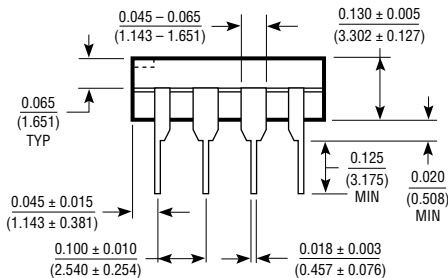
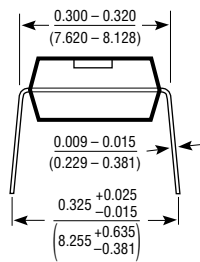

S8 Package
8-Lead
Plastic SOIC

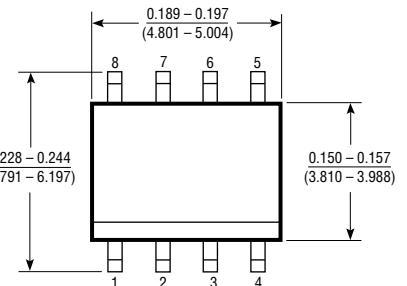
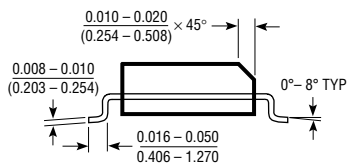

Looking for pricing, stock, or lifecycle information?

Click below to explore more details on WIN SOURCE:

 [View LTC1165CS8#PBF on WIN SOURCE](#)

 [Linear Technology](#) Information

Optimize Your Supply Chain with WIN SOURCE Solutions

-  Global Sourcing Solution
-  Obsolete Management
-  Cost Control Management
-  Shortage Management
-  Alternative Solution
-  Excess Inventory Management