



**THE DATASHEET OF
LTC1155IN8#PBF**



LTC1155

ABSOLUTE MAXIMUM RATINGS (Note 1)

Supply Voltage.....22V	Operating Temperature Range
Input Voltage.....($V_S + 0.3V$) to ($GND - 0.3V$)	LTC1155C 0°C to 70°C
Gate Voltage.....($V_S + 24V$) to ($GND - 0.3V$)	LTC1155I -40°C to 85°C
Current (Any Pin).....50mA	LTC1155M (OBSOLETE) -55°C to 125°C
Storage Temperature Range..... -65°C to 150°C	Lead Temperature Range (Soldering, 10 sec.) 300°C

PIN CONFIGURATION

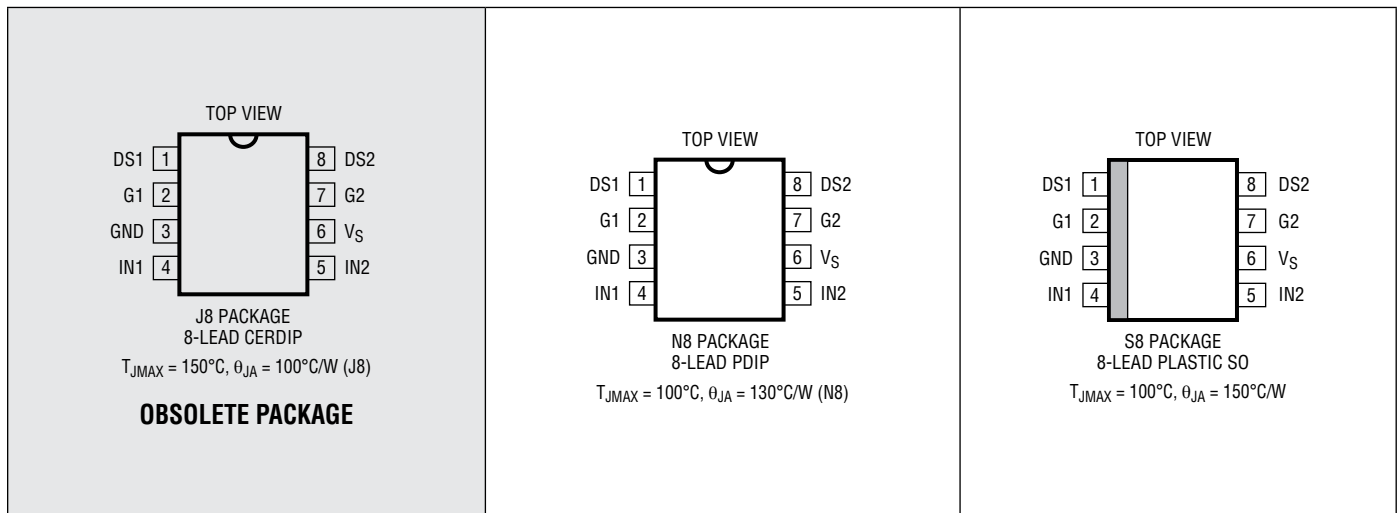

ORDER INFORMATION

LEAD FREE FINISH	TAPE AND REEL	PART MARKING*	PACKAGE DESCRIPTION	TEMPERATURE RANGE
LTC1155CN8#PBF	LTC1155CN8#TRPBF		8-Lead PDIP	0°C to 70°C
LTC1155IN8#PBF	LTC1155IN8#TRPBF		8-Lead PDIP	-40°C to 85°C
OBSOLETE PACKAGE				
LTC1155CJ8#PBF	LTC1155CJ8#TRPBF		8-Lead CERDIP	0°C to 70°C
LTC1155MJ8#PBF	LTC1155MJ8#TRPBF		8-Lead CERDIP	-55°C to 125°C
LTC1155CS8#PBF	LTC1155CS8#TRPBF	1155	8-Lead Plastic SO	0°C to 70°C
LTC1155IS8#PBF	LTC1155IS8#TRPBF	1155I	8-Lead Plastic SO	-40°C to 85°C

Contact the factory for parts specified with wider operating temperature ranges. *The temperature grade is identified by a label on the shipping container.

[Tape and reel specifications](#). Some packages are available in 500 unit reels through designated sales channels with #TRMPBF suffix.

ELECTRICAL CHARACTERISTICS

The ● denotes the specifications which apply over the full operating temperature range, otherwise specifications are at $T_A = 25^\circ\text{C}$. $V_S = 4.5\text{V}$ to 18V , unless otherwise noted.

SYMBOL	PARAMETER	CONDITIONS		LTC1155M (OBSOLETE)			LTC1155C/LTC1155I			UNITS
				MIN	TYP	MAX	MIN	TYP	MAX	
V_S	Supply Voltage		●	4.5		18	4.5		18	V
I_Q	Quiescent Current OFF	$V_{IN} = 0\text{V}$, $V_S = 5\text{V}$ (Note 2)			8	20		8	20	μA
	Quiescent Current ON	$V_S = 5\text{V}$, $V_{IN} = 5\text{V}$ (Note 3)			85	120		85	120	μA
	Quiescent Current ON	$V_S = 12\text{V}$, $V_{IN} = 5\text{V}$ (Note 3)			180	400		180	400	μA
V_{INH}	Input High Voltage		●	2.0			2.0			V
V_{INL}	Input Low Voltage		●			0.8			0.8	V
I_{IN}	Input Current	$0\text{V} < V_{IN} < V_S$	●			± 1.0			± 1.0	μA
C_{IN}	Input Capacitance				5			5		pF
V_{SEN}	Drain Sense Threshold Voltage		●	80	100	120	80	100	120	mV
				75	100	125	75	100	125	mV
I_{SEN}	Drain Sense Input Current	$0\text{V} < V_{SEN} < V_S$				± 0.1			± 0.1	μA
V_{GATE-V_S}	Gate Voltage Above Supply	$V_S = 5\text{V}$ $V_S = 6\text{V}$ $V_S = 12\text{V}$	●	6.0	6.8	9.0	6.0	6.8	9.0	V
			●	7.5	8.5	15	7.5	8.5	15	V
			●	15	18	25	15	18	25	V
t_{ON}	Turn ON Time	$V_S = 5\text{V}$, $C_{GATE} = 1000\text{pF}$ Time for $V_{GATE} > V_S + 2\text{V}$ Time for $V_{GATE} > V_S + 5\text{V}$		50	250	750	50	250	750	μs
				200	1100	2000	200	1100	2000	μs
t_{OFF}	Turn OFF Time	$V_S = 5\text{V}$, $C_{GATE} = 1000\text{pF}$ Time for $V_{GATE} > V_S + 5\text{V}$ Time for $V_{GATE} > V_S + 10\text{V}$		50	180	500	50	180	500	μs
				120	450	1200	120	450	1200	μs
t_{OFF}	Turn OFF Time	$V_S = 5\text{V}$, $C_{GATE} = 1000\text{pF}$ Time for $V_{GATE} < 1\text{V}$		10	36	60	10	36	60	μs
				10	26	60	10	26	60	μs
t_{SC}	Short-Circuit Turn OFF Time	$V_S = 5\text{V}$, $C_{GATE} = 1000\text{pF}$ Time for $V_{GATE} < 1\text{V}$		5	16	30	5	16	30	μs
				5	16	30	5	16	30	μs

Note 1: Absolute Maximum Ratings are those values beyond which the life of a device may be impaired.

Note 2: Quiescent current OFF is for both channels in OFF condition.

Note 3: Quiescent current ON is per driver and is measured independently.

TYPICAL PERFORMANCE CHARACTERISTICS

Standby Supply Current

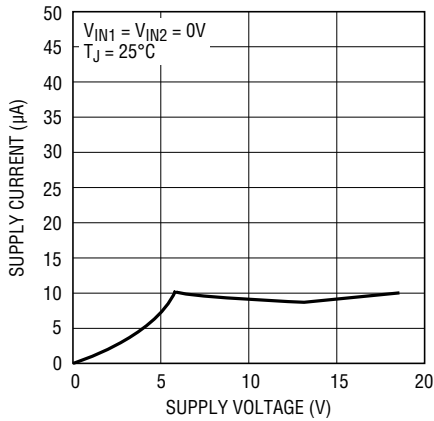

Supply Current/Side (ON)

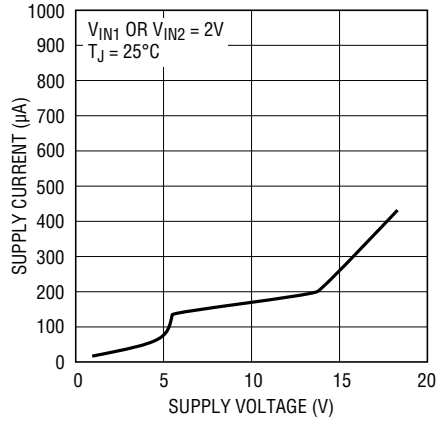

High Side Gate Voltage

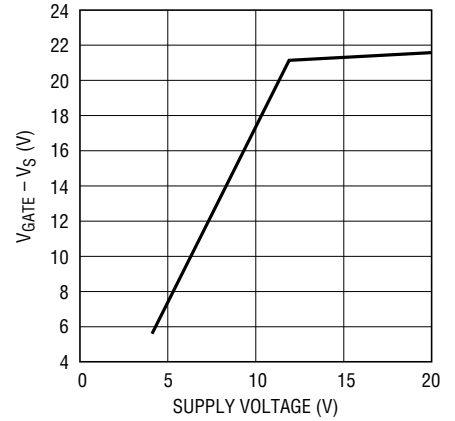

Input Threshold Voltage

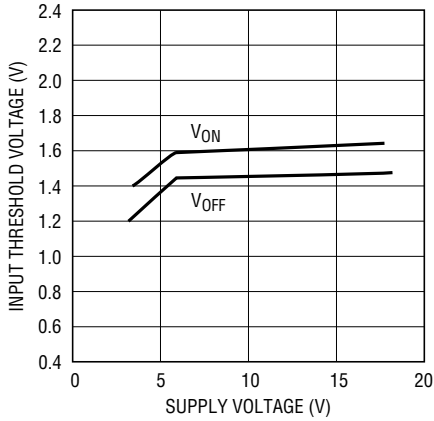

Drain Sense Threshold Voltage

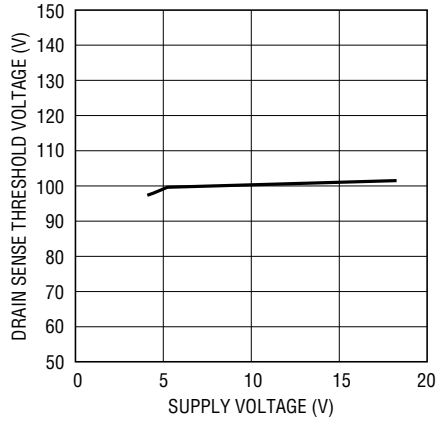

Low Side Gate Voltage

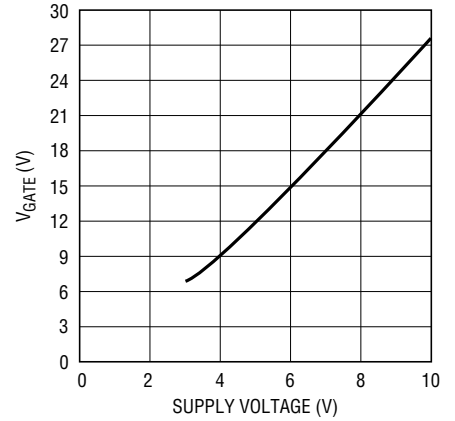

Turn ON Time

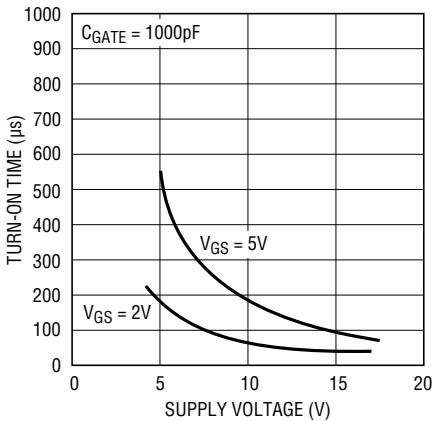

Turn OFF Time

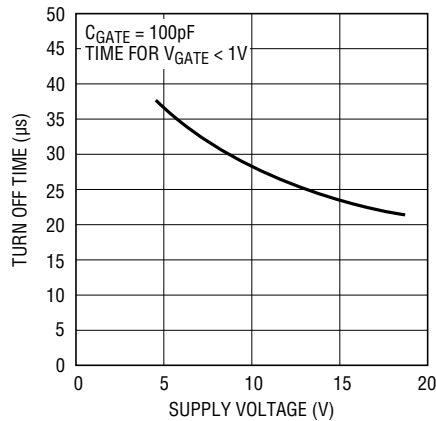

Short-Circuit Turn OFF Delay Time

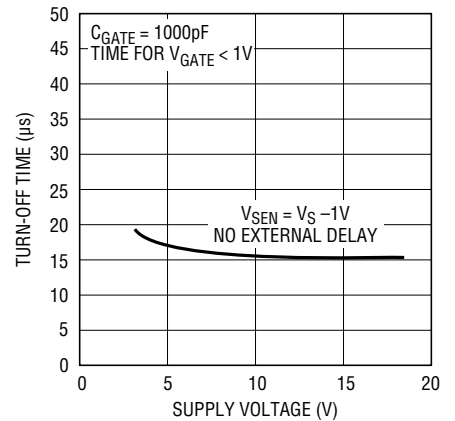

TYPICAL PERFORMANCE CHARACTERISTICS

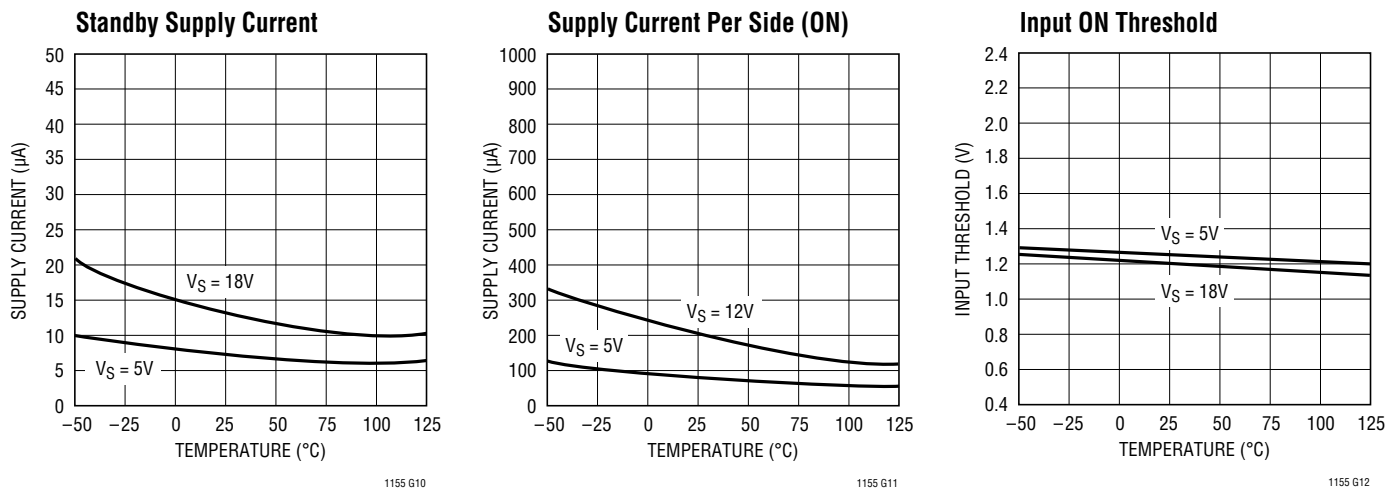

PIN FUNCTIONS

Input Pin

The LTC1155 logic input is a high impedance CMOS gate and should be grounded when not in use. These input pins have ESD protection diodes to ground and supply and, therefore, should not be forced beyond the power supply rails.

Gate Drive Pin

The gate drive pin is either driven to ground when the switch is turned OFF or driven above the supply rail when the switch is turned ON. This pin is a relatively high impedance when driven above the rail (the equivalent of a few hundred $\text{k}\Omega$). Care should be taken to minimize any loading of this pin by parasitic resistance to ground or supply.

Supply Pin

The supply pin of the LTC1155 serves two vital purposes. The first is obvious: it powers the input, gate drive, regulation and protection circuitry. The second purpose is less obvious: it provides a Kelvin connection to the top of the two drain sense resistors for the internal 100mV reference. The supply pin should be connected directly to the power supply source as close as possible to the top of the two sense resistors.

The supply pin of the LTC1155 should not be forced below ground as this may result in permanent damage to the device. A 300Ω resistor should be inserted in series with the ground pin if negative supply voltages are anticipated.

Drain Sense Pin

As noted previously, the drain sense pin is compared against the supply pin voltage. If the voltage at this pin is more than 100mV below the supply pin, the input latch will be reset and the MOSFET gate will be quickly discharged. Cycle the input to reset the short-circuit latch and turn the MOSFET back on.

This pin is also a high impedance CMOS gate with ESD protection and, therefore, should not be forced beyond the power supply rails. To defeat the over current protection, short the drain sense to supply.

Some loads, such as large supply capacitors, lamps or motors require high inrush currents. An RC time delay must be added between the sense resistor and the drain sense pin to ensure that the drain sense circuitry does not false trigger during start-up. This time constant can be set from a few microseconds to many seconds. However, very long delays may put the MOSFET in risk of being destroyed by a short-circuit condition (see Applications Information section).

BLOCK DIAGRAM

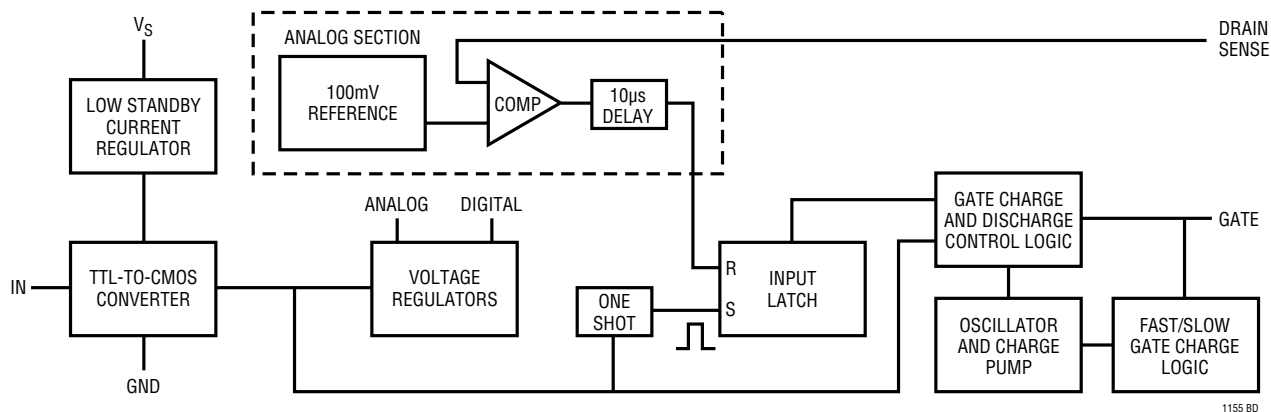

OPERATION

The LTC1155 contains two independent power MOSFET gate drivers and protection circuits (refer to the Block Diagram for details). Each half of the LTC1155 consists of the following functional blocks:

TTL and CMOS Compatible Inputs

Each driver input has been designed to accommodate a wide range of logic families. The input threshold is set at 1.3V with approximately 100mV of hysteresis.

A voltage regulator with low standby current provides continuous bias for the TTL to CMOS converters. The TTL to CMOS converter output enables the rest of the circuitry. In this way the power consumption is kept to a minimum in the standby mode.

Internal Voltage Regulation

The output of the TTL to CMOS converter drives two regulated supplies which power the low voltage CMOS logic and analog blocks. The regulator outputs are isolated from each other so that the noise generated by the charge pump logic is not coupled into the 100mV reference or the analog comparator.

Gate Charge Pump

Gate drive for the power MOSFET is produced by an adaptive charge pump circuit that generates a gate voltage substantially higher than the power supply voltage. The charge pump capacitors are included on-chip and, therefore, no external components are required to generate the gate drive.

Drain Current Sense

The LTC1155 is configured to sense the drain current of the power MOSFET in high side applications. An internal 100mV reference is compared to the drop across a sense resistor (typically 0.002Ω to 0.1Ω) in series with the drain lead. If the drop across this resistor exceeds the internal 100mV threshold, the input latch is reset and the gate is quickly discharged by a large N-channel transistor.

Controlled Gate Rise and Fall Times

When the input is switched ON and OFF, the gate is charged by the internal charge pump and discharged in a controlled manner. The charge and discharge rates have been set to minimize RFI and EMI emissions in normal operation. If a short circuit or current overload condition is encountered, the gate is discharged very quickly (typically a few microseconds) by a large N-channel transistor.

APPLICATIONS INFORMATION

Protecting the MOSFET

The MOSFET is protected against destruction by removing drive from the gate as soon as an overcurrent condition is detected. Resistive and inductive loads can be protected with no external time delay. Large capacitive or lamp loads, however, require that the overcurrent shutdown function be delayed long enough to start the load but short enough to ensure the safety of the MOSFET.

Example Calculations

Consider the circuit of Figure 1. A power MOSFET is driven by one side of an LTC1155 to switch a high inrush current load. The drain sense resistor is selected to limit the maximum DC current to 3.3A.

$$\begin{aligned} R_{SEN} &= V_{SEN}/I_{TRIP} \\ &= 0.1/3.3A \\ &= 0.03\Omega \end{aligned}$$

A time delay is introduced between R_{SEN} and the drain sense pin of the LTC1155 which provides sufficient delay to start a high inrush load such as large supply capacitors.

In this example circuit, we have selected the IRLZ34 because of its low $R_{DS(ON)}$ (0.05Ω with $V_{GS} = 5V$). The FET drops 0.1V at 2A and, therefore, dissipates 200mW in normal operation (no heat sinking required).

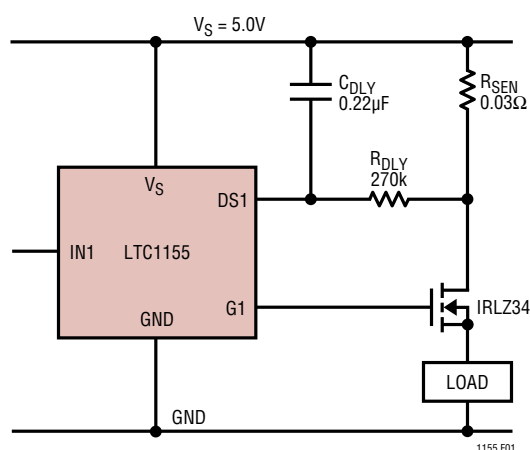

Figure 1. Adding an RC Delay

If the output is shorted to ground, the current through the FET rises rapidly and is limited by the $R_{DS(ON)}$ of the FET, the drain sense resistor and the series resistance between the power supply and the FET. Series resistance

in the power supply can be substantial and attributed to many sources including harness wiring, PCB traces, supply capacitor ESR, transformer resistance or battery resistance.

For this example, we assume a worst-case scenario; i.e., that the power supply to the power MOSFET is “hard” and provides a constant 5V regardless of the current. In this case, the current is limited by the $R_{DS(ON)}$ of the MOSFET and the drain sense resistance. Therefore:

$$\begin{aligned} I_{PEAK} &= V_{SUPPLY}/0.08\Omega \\ &= 62.5A \end{aligned}$$

The drop across the drain sense resistor under these conditions is much larger than 100mV and is equal to the drain current times the sense resistance:

$$\begin{aligned} V_{DROP} &= (I_{PEAK})(R_{SEN}) \\ &= 1.88V \end{aligned}$$

By consulting the power MOSFET data sheet SOA graph, we note that the IRLZ34 is capable of delivering 62.5A at a drain-to-source voltage of 3.12V for approximately 10ms.

An RC time constant can now be calculated which satisfies this requirement:

$$\begin{aligned} RC &= \frac{-t}{\ln \left[1 - \frac{V_{SEN}}{R_{SEN} \cdot I_{MAX}} \right]} \\ RC &= \frac{-0.01}{\ln \left[1 - \frac{0.10}{0.030 \cdot 62.5} \right]} \\ &= -0.01/-0.054 \\ &= 182ms \end{aligned}$$

This time constant should be viewed as a maximum safe delay time and should be reduced if the competing requirement of starting a high inrush current load is less stringent; i.e., if the inrush time period is calculated at 20ms, the RC time constant should be set at roughly two or three times this time period and not at the maximum of 182ms. A 60ms time constant would be produced with a 270k resistor and a 0.22μF capacitor (as shown in Figure 1).

APPLICATIONS INFORMATION

Graphical Approach to Selecting R_{DLY} and C_{DLY}

Figure 2 is a graph of normalized overcurrent shutdown time versus normalized MOSFET current. This graph can be used instead of the above equation to calculate the RC time constant. The Y axis of the graph is normalized to one RC time constant. The X axis is normalized to the set current. (The set current is defined as the current required to develop 100mV across the drain sense resistor).

Note that the shutdown time is shorter for increasing levels of MOSFET current. This ensures that the total energy dissipated by the MOSFET is always within the bounds established by the MOSFET manufacturer for safe operation.

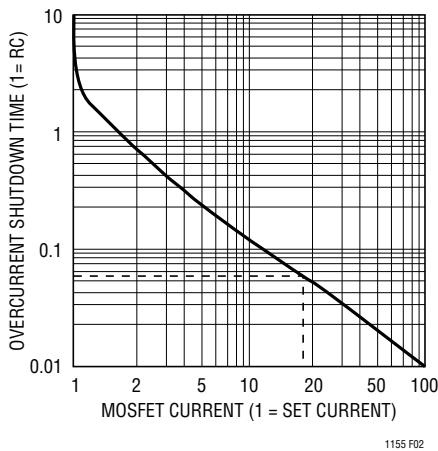

Figure 2. Shutdown Time vs MOSFET Current

In the example presented above, we established that the power MOSFET should not be allowed to pass 62.5A for more than 10ms. 62.5A is roughly 18 times the set current of 3.3A. By drawing a line up from 18 and reflecting it off the curve, we establish that the RC time constant should be set at 10ms divided by 0.054, or 180ms. Both methods result in the same conclusion.

Using a Speed Up Diode

A way to further reduce the amount of time that the power MOSFET is in a short-circuit condition is to “bypass” the delay resistor with a small signal diode as shown in Figure 3. The diode will engage when the drop across the drain sense resistor exceeds 0.7V, providing a direct path

to the sense pin and dramatically reducing the amount of time the MOSFET is in an overload condition. The drain sense resistor value is selected to limit the maximum DC current to 4A. Above 28A, the delay time drops to 10 μ s.

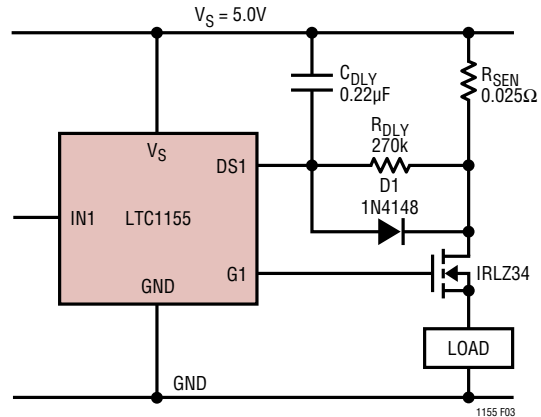

Figure 3. Using a Speed-Up Diode

Switched Supply Applications

Large inductive loads, such as solenoids, relays and motors store energy which must be directed back to either the power supply or to ground when the supply voltage is interrupted (see Figure 4). In normal operation, when the switch is turned OFF, the energy stored in the inductor is harmlessly absorbed by the MOSFET; i.e., the current flows out of the supply through the MOSFET until the inductor current falls to zero.

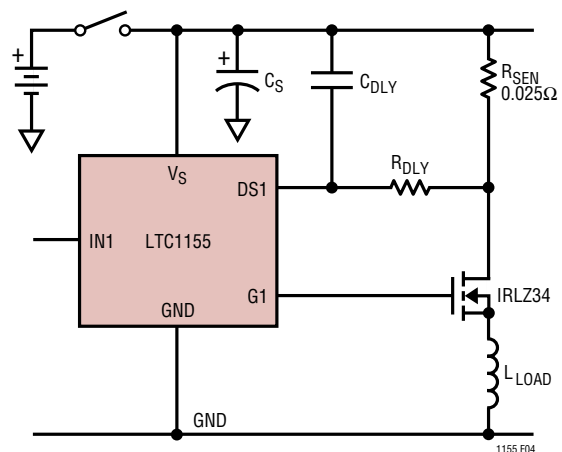

Figure 4. Switched Supply

APPLICATIONS INFORMATION

If the MOSFET is turned ON and the power supply (battery) removed, the inductor current is delivered by the supply capacitor. The supply capacitor must be large enough to deliver the energy demanded by the discharging inductor. *If the storage capacitor is too small, the supply lead of the LTC1155 may be pulled below ground, permanently destroying the device.*

Consider the case of a load inductance of 1mH which is supporting 3A when the 6V power supply connection is interrupted. A supply capacitor of at least 250 μ F is required to prevent the supply lead of the LTC1155 from being pulled below ground (along with any other circuitry tied to the supply).

Any wire between the power MOSFET source and the load will add a small amount of parasitic inductance in series with the load (approximately 0.4 μ H/foot). Bypass the power supply lead of the LTC1155 with a minimum of 10 μ F to ensure that this parasitic load inductance is discharged safely, even if the load is otherwise resistive.

Large Inductive Loads

Large inductive loads (>0.1mH) may require diodes connected directly across the inductor to safely divert the stored energy to ground. Many inductive loads have these diodes included. If not, a diode of the proper current rating should be connected across the load to safely divert the stored energy.

Reverse-Battery Protection

The LTC1155 can be protected against reverse-battery conditions by connecting a resistor in series with the ground lead as shown in Figure 5. The resistor limits the supply current to less than 50mA with -12 V applied. Since the LTC1155 draws very little current while in normal operation, the drop across the ground resistor is minimal.

The TTL or CMOS driving logic is protected against reverse-battery conditions by the 100k input current limiting resistor. The addition of 100k resistance in series with the input pin will not affect the turn ON and turn OFF times which are dominated by the controlled gate charge and discharge periods.

Overvoltage Protection

The MOSFET and load can be protected against overvoltage conditions by using the circuit of Figure 6. The drain sense function is used to detect an overvoltage condition and quickly discharge the power MOSFET gate. The 18V zener diode conducts when the supply voltage exceeds 18.6V and pulls the drain sense pin 0.6V below the supply pin voltage.

The supply voltage is limited to 18.6V and the gate drive is immediately removed from the MOSFET to ensure that it cannot conduct during the overvoltage period. The gate of the MOSFET will be latched OFF until the supply transient is removed and the input turned OFF and ON again.

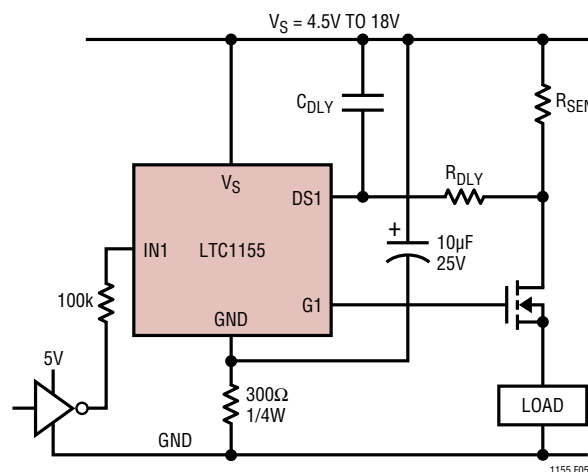

Figure 5. Reverse Battery Protection

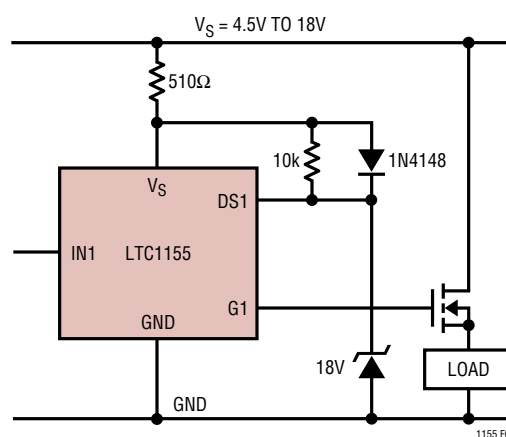
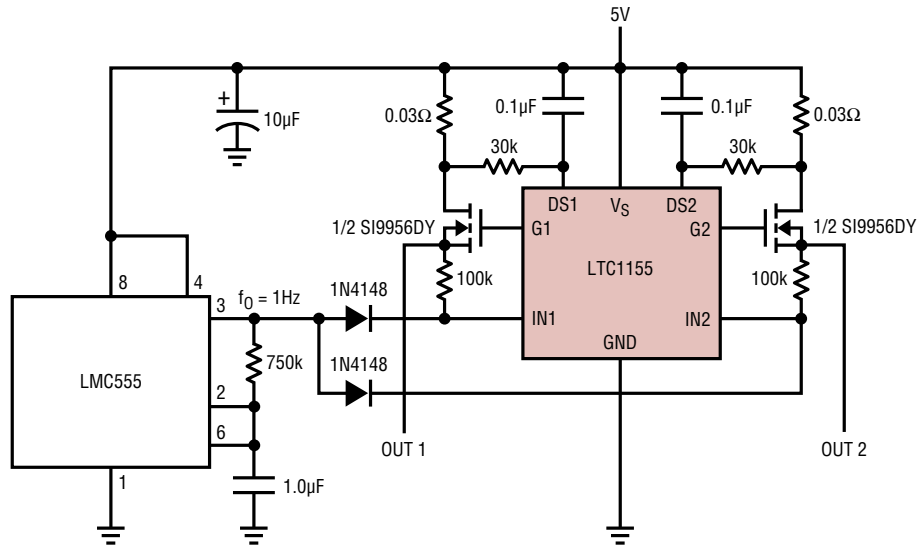

Figure 6. Overvoltage Shutdown and Protection

TYPICAL APPLICATIONS

Dual 2A Autoreset Electronic Fuse



ALL COMPONENTS SHOWN ARE SURFACE MOUNT

1155 TA03

High Side Driver with V_{DS} Sense Short-Circuit Shutdown

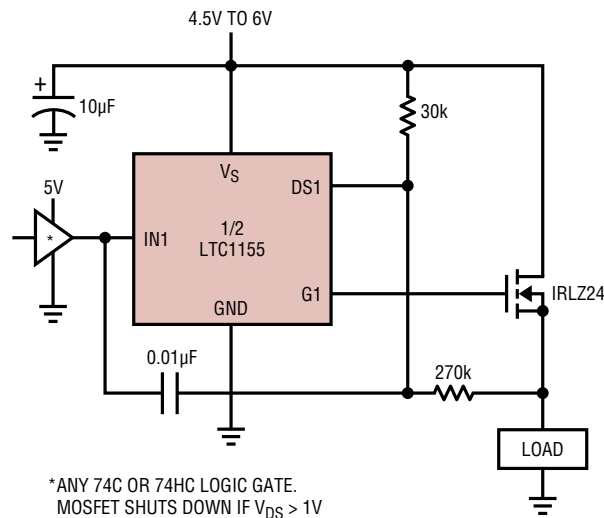

*ANY 74C OR 74HC LOGIC GATE.
MOSFET SHUTS DOWN IF $V_{DS} > 1V$

1155 TA04

TYPICAL APPLICATIONS

X-NOR Fault Detection

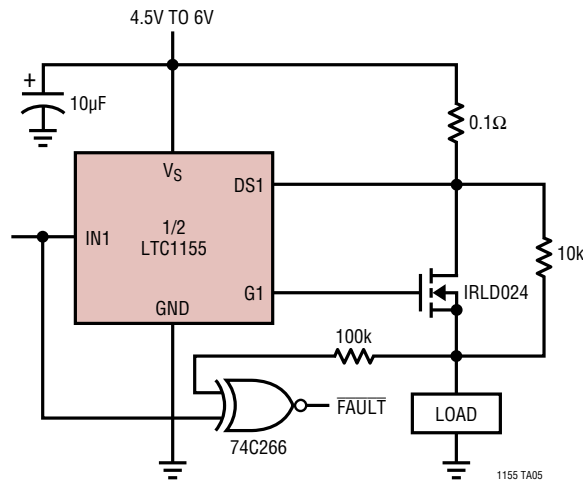

Truth Table

IN	OUT	CONDITION	FLT
0	0	Switch OFF	1
1	0	Short Circuit	0
0	1	Open Load	0
1	1	Switch ON	1

Low Side Driver with Drain End Current Sensing

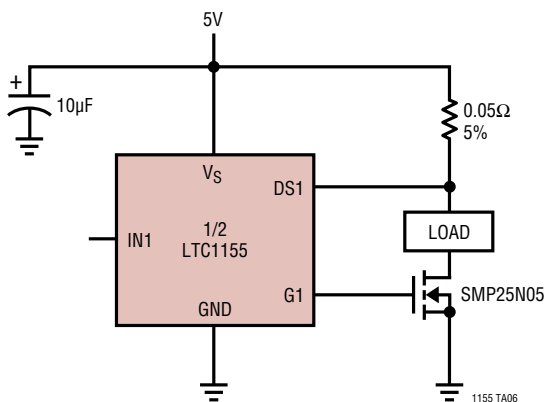

Low Side Driver with Source End Current Sensing

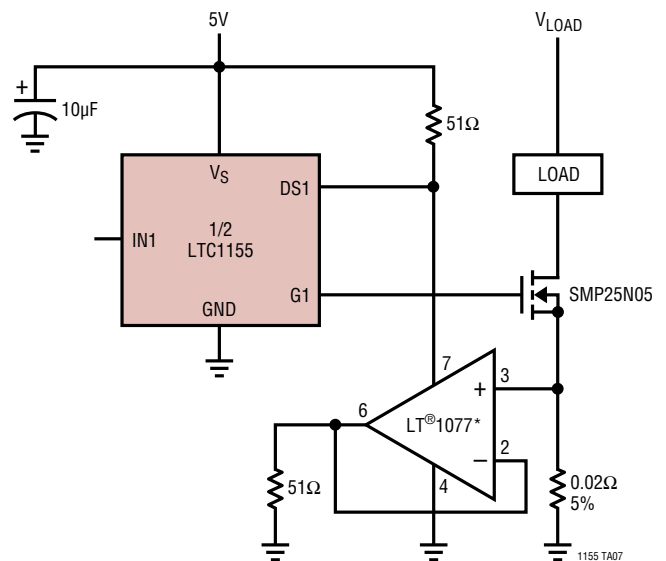

*DO NOT SUBSTITUTE. MUST BE A PRECISION, SINGLE SUPPLY, MICROPOWER OP AMP ($I_Q < 60\mu A$)

TYPICAL APPLICATIONS

Automotive High Side Driver with Reverse-Battery and High Voltage Transient Protection

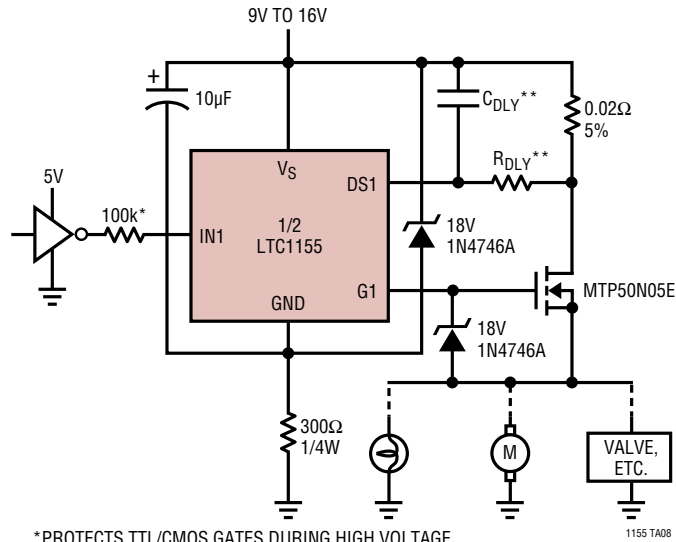

*PROTECTS TTL/CMOS GATES DURING HIGH VOLTAGE TRANSIENT OR REVERSE BATTERY
 **NOT REQUIRED FOR INDUCTIVE OR RESISTIVE LOADS

Using the Second Channel for Fault Detection

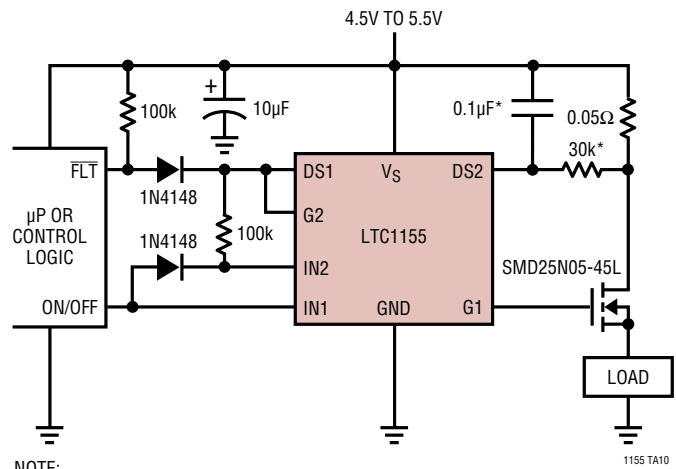

NOTE:
 DRAIN SENSE 2 IS USED TO DETECT A FAULT IN CHANNEL 1.
 GATE 2 PULLS DOWN ON DRAIN SENSE 1 TO DISCHARGE THE MOSFET AND REPORT THE FAULT TO THE µP
 *NOT REQUIRED FOR RESISTIVE OR INDUCTIVE LOADS

TYPICAL APPLICATIONS

5V/3A Extremely Low Voltage Drop Regulator with 10 μ A Standby Current and Short-Circuit Protection

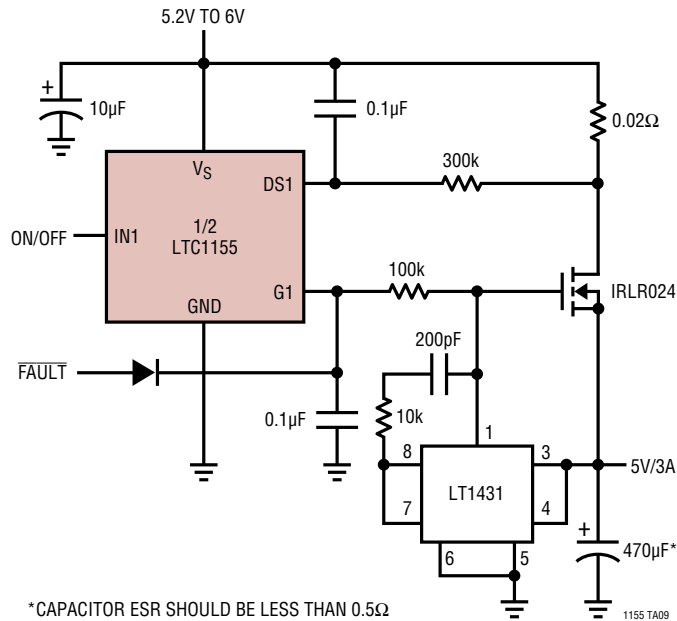

Bootstrapped Gate Drive for (100Hz F_0 <math>< 10kHz</math>)

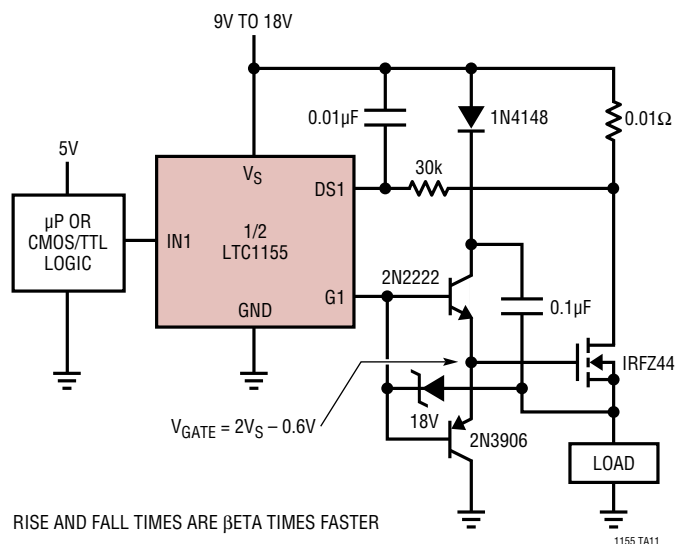

TYPICAL APPLICATIONS

High Efficiency 60Hz Full-Wave Synchronous Rectifier

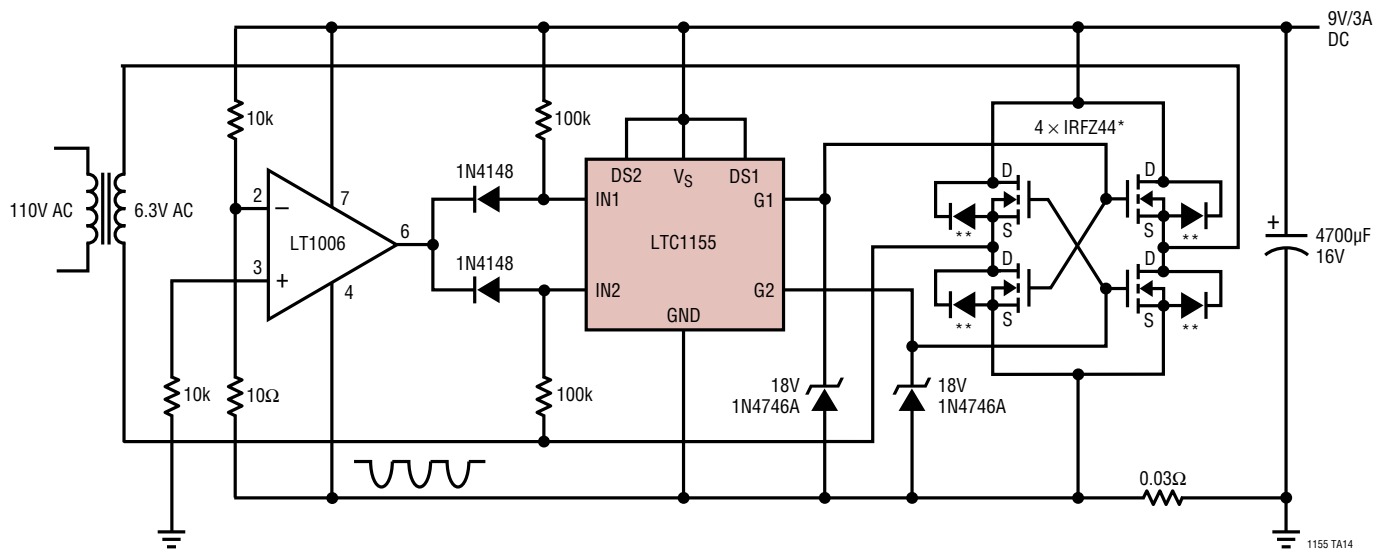

MOSFETs ARE SYNCHRONOUSLY ENHANCED WHEN RECTIFIER CURRENT EXCEEDS 300mA
 *NO HEATSINK REQUIRED
 **INTERNAL BODY DIODE OF MOSFET

Push-Pull Driver with Shoot-Through Current Lockout ($f_0 < 100\text{Hz}$)

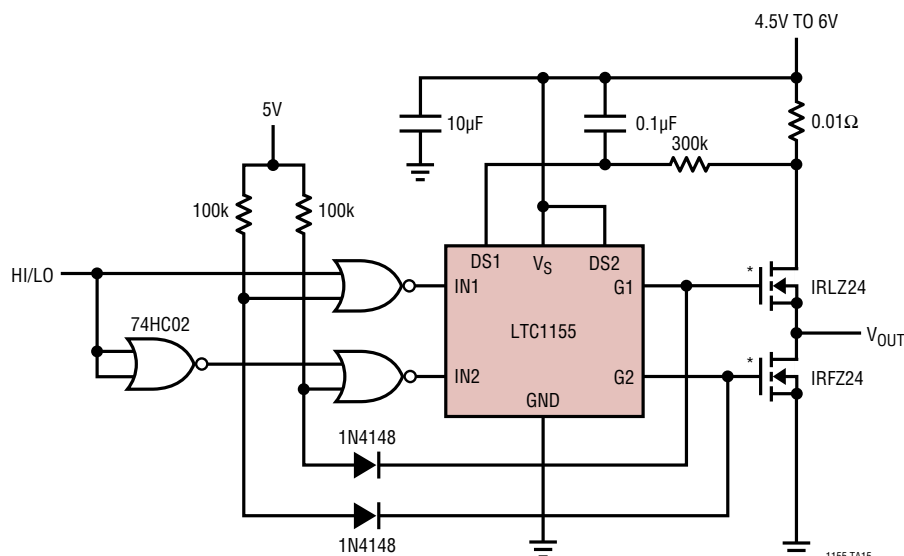

*OPPOSING GATE MUST DROP BELOW 2V BEFORE THE OTHER IS CHARGED

TYPICAL APPLICATIONS

Full H-Bridge Driver with Shoot-Through Current Lockout and Stall Current Shutdown ($f_0 < 100\text{Hz}$)

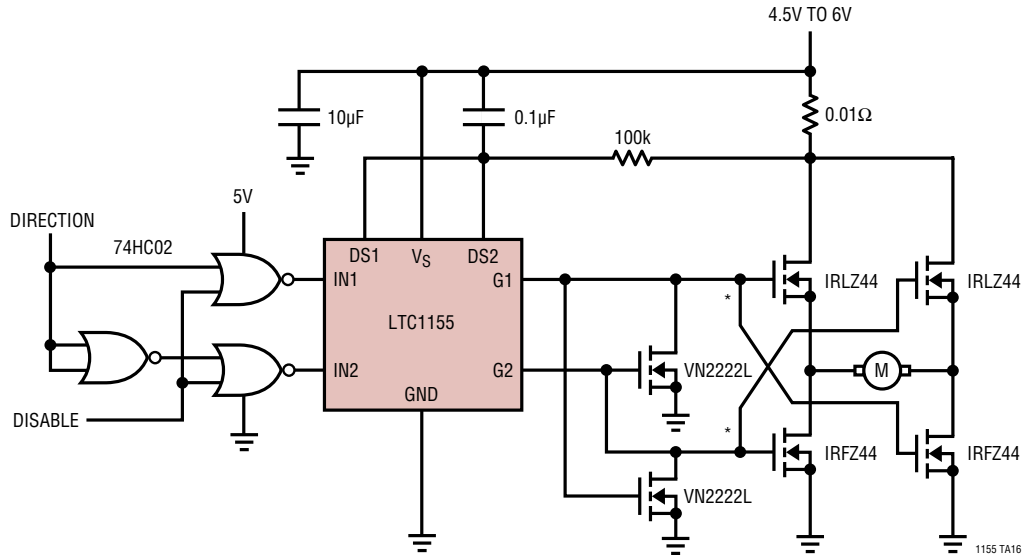

DC Motor Speed and Torque Control for Cordless Tools and Appliances

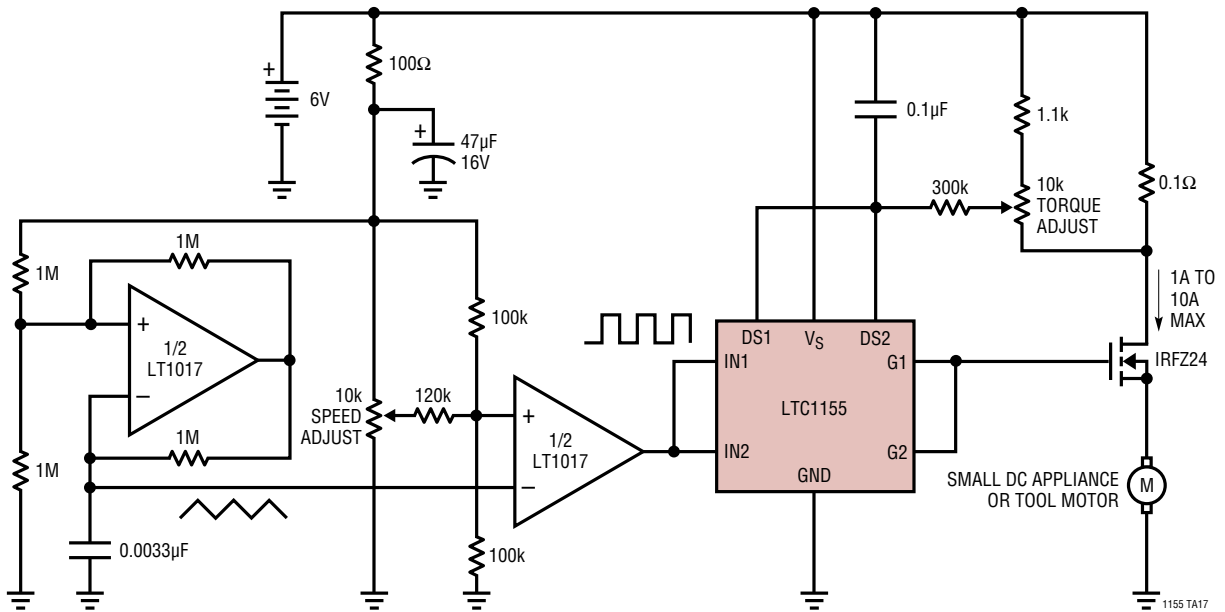

SPEED IS PROPORTIONAL TO PULSE WIDTH. TORQUE IS PROPORTIONAL TO CURRENT

PACKAGE DESCRIPTION

J8 Package
8-Lead CERDIP (Narrow .300 Inch, Hermetic)
 (Reference LTC DWG # 05-08-1110)

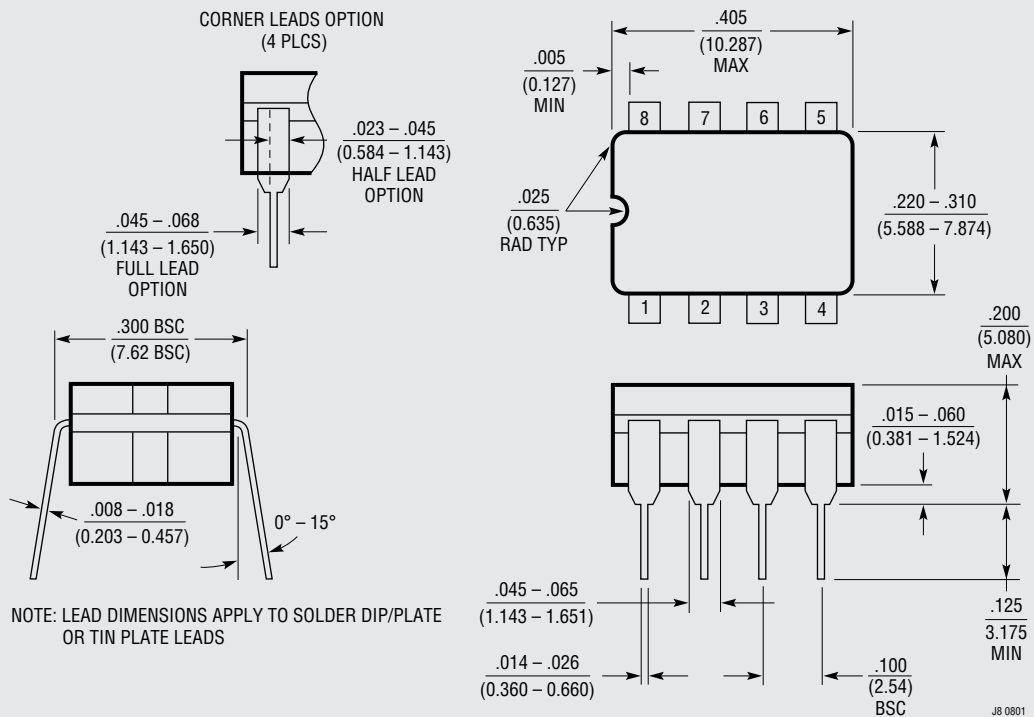

OBsolete PACKAGE

PACKAGE DESCRIPTION

N Package
8-Lead PDIP (Narrow .300 Inch)
 (Reference LTC DWG # 05-08-1510 Rev I)

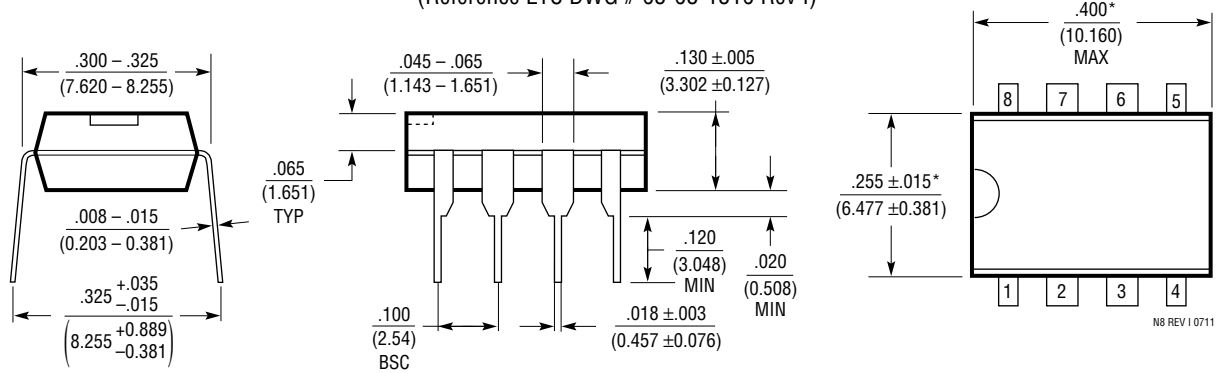

NOTE:
 1. DIMENSIONS ARE $\frac{\text{INCHES}}{\text{MILLIMETERS}}$
 *THESE DIMENSIONS DO NOT INCLUDE MOLD FLASH OR PROTRUSIONS.
 MOLD FLASH OR PROTRUSIONS SHALL NOT EXCEED .010 INCH (0.254mm)

S8 Package
8-Lead Plastic Small Outline (Narrow .150 Inch)
 (Reference LTC DWG # 05-08-1610 Rev G)

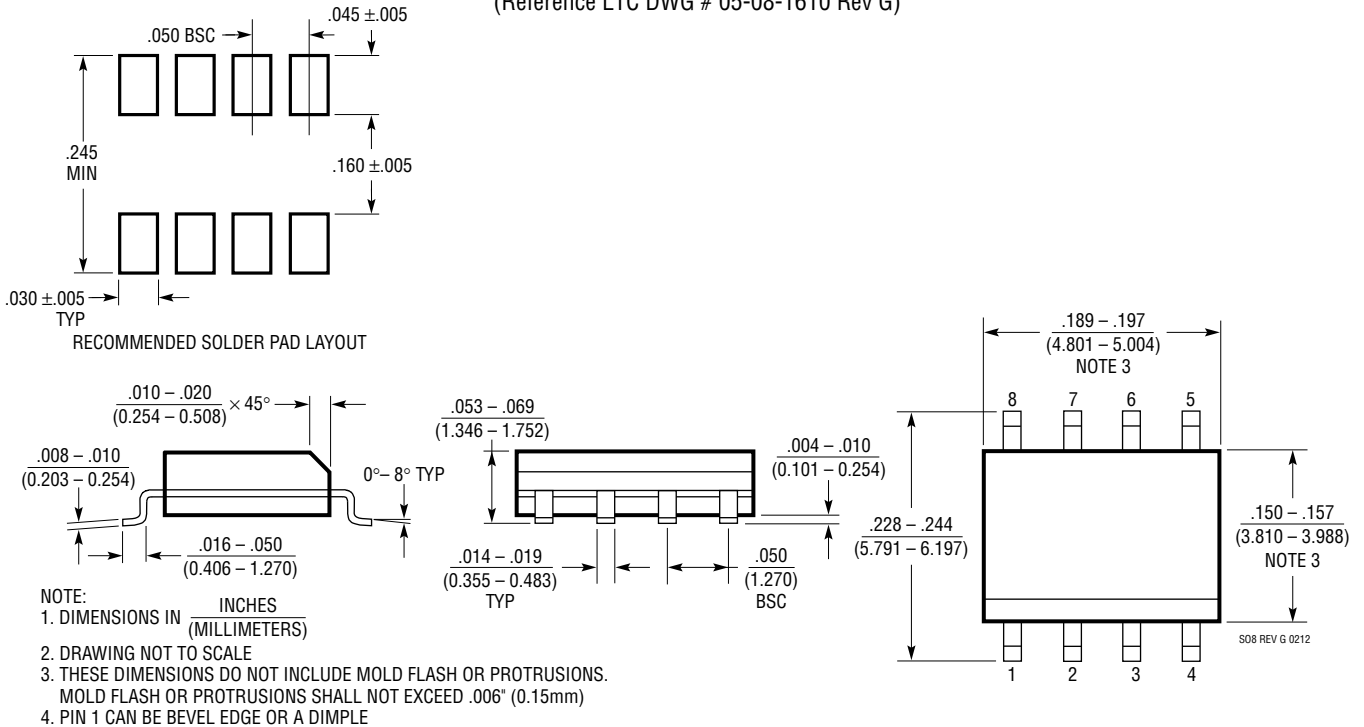

NOTE:
 1. DIMENSIONS IN $\frac{\text{INCHES}}{\text{MILLIMETERS}}$
 2. DRAWING NOT TO SCALE
 3. THESE DIMENSIONS DO NOT INCLUDE MOLD FLASH OR PROTRUSIONS.
 MOLD FLASH OR PROTRUSIONS SHALL NOT EXCEED .006" (0.15mm)
 4. PIN 1 CAN BE BEVEL EDGE OR A DIMPLE

REVISION HISTORY (Revision history begins at Rev C)

REV	DATE	DESCRIPTION	PAGE NUMBER
C	05/19	Obsoleted CERDIP J8 package	2, 17

TYPICAL APPLICATIONS

Isolated High Voltage High Side Switch with Circuit Breaker

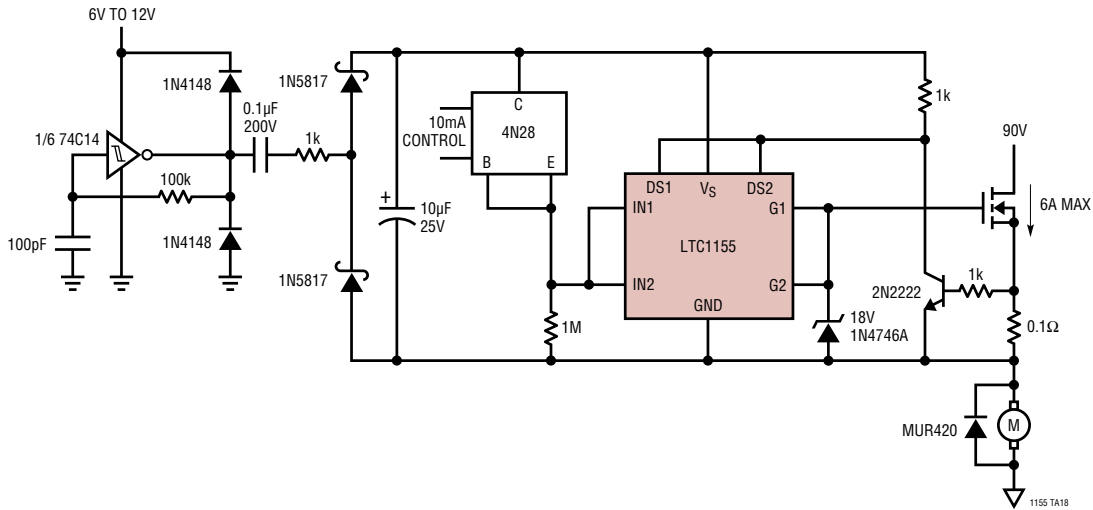

Isolated Solid-State AC Relay with Circuit Breaker

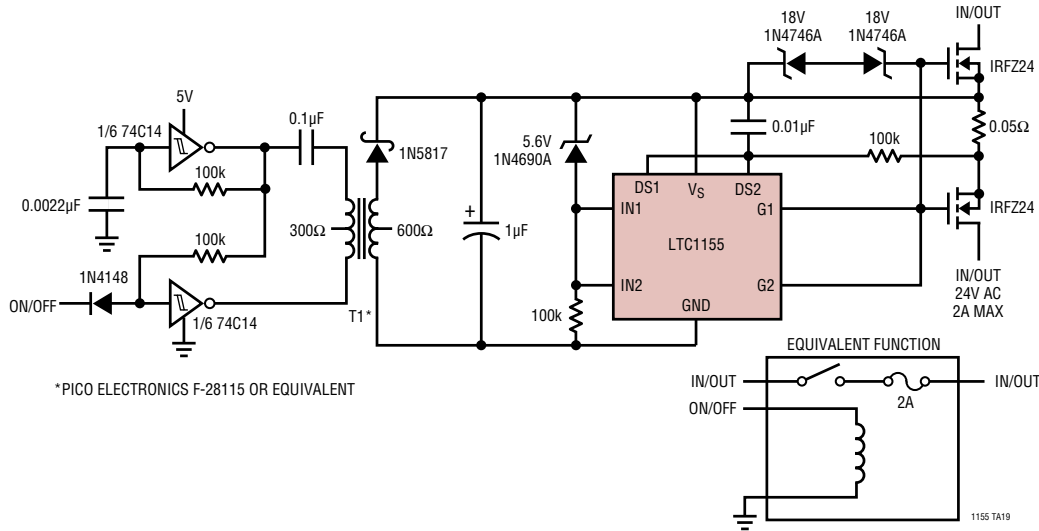

RELATED PARTS

PART NUMBER	DESCRIPTION	COMMENTS
LTC1153	Auto-Reset Electronic Circuit Breaker	Programmable Trip Current, Fault Status Output
LT1161	Quad Protected High Side MOSFET Driver	8V to 48V Supply Range, Individual Short-Circuit Protection
LTC1163	Triple 1.8V to 6V High Side MOSFET Driver	0.01µA Standby Current, Triple Driver in SO-8 Package
LTC1255	Dual 24V High Side MOSFET Driver	Operates from 9V to 24V, Short-Circuit Protection
LTC1477	Protected Monolithic High Side Switch	Low $R_{DS(ON)}$ 0.07Ω Switch, 2A Short-Circuit Protected
LTC1623	SMBus Dual High Side Switch Controller	2-Wire SMBus Serial Interface, Built-In Gate Charge Pumps
LTC1710	SMBus Dual Monolithic High Side Switch	Two Low $R_{DS(ON)}$ 0.4Ω/300mA Switches in 8-Lead MSOP Package
LT1910	Protected High Side MOSFET Driver	8V to 48V Supply Range, Fault Status Output

Looking for pricing, stock, or lifecycle information?

Click below to explore more details on WIN SOURCE:

 [View LTC1155IN8#PBF on WIN SOURCE](#)

 [Linear Technology](#) Information

Optimize Your Supply Chain with WIN SOURCE Solutions

-  Global Sourcing Solution
-  Obsolete Management
-  Cost Control Management
-  Shortage Management
-  Alternative Solution
-  Excess Inventory Management