

Low Noise, Fast, Quad Universal Filter Building Block

FEATURES

- Four Filters in a 0.3 Inch Wide Package
- Maximum Center Frequency: 140kHz
- Customized Version with Internal Resistors Available
- One Half the Noise of the LTC1059/LTC1060/LTC1061 Devices
- Maximum Clock Frequency: 7MHz
- Clock-to-Center Frequency Ratio of 50:1 and 100:1 Simultaneously Available
- Power Supplies: $\pm 2.375V$ to $\pm 8V$
- Low Offsets
- Low Harmonic Distortion
- Available in 24-Pin DIP and SO Wide Packages

APPLICATIONS

- Anti-Aliasing Filters
- Wide Frequency Range Tracking Filters
- Spectral Analysis
- Loop Filters

DESCRIPTION

The LTC[®]1064 consists of four high speed, low noise switched-capacitor filter building blocks. Each filter building block, together with an external clock and three to five resistors can provide various 2nd order functions like lowpass, highpass, bandpass and notch. The center frequency of each 2nd order function can be tuned with an external clock, or a clock and resistor ratio. For $Q \leq 5$, the center frequency range is from 0.1Hz to 100kHz. For $Q \leq 3$, the center frequency range can be extended to 140kHz. Up to 8th order filters can be realized by cascading all four 2nd order sections. Any classical filter realization (such as Butterworth, Cauer, Bessel and Chebyshev) can be formed.

A customized monolithic version of the LTC1064 including internal thin film resistors can be obtained for high volume applications. Consult LTC Marketing for details.

LT, LTC and LT are registered trademarks of Linear Technology Corporation. LTCMOS is a trademark of Linear Technology Corporation. All other trademarks are the property of their respective owners.

TYPICAL APPLICATION

Clock-Tunable 8th Order Cauer Lowpass Filter with f_{CUTOFF} up to 100kHz

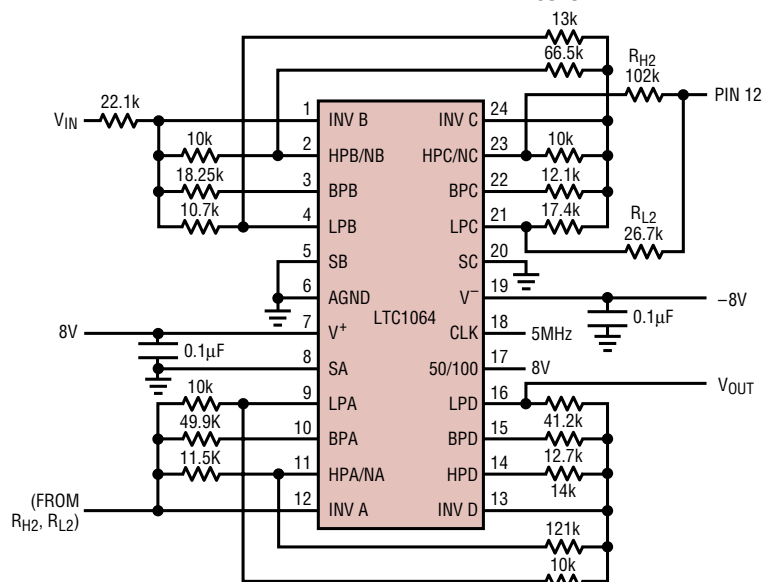

FOR $f_{CLK} = 5MHz$, ADD $C1 = 10pF$ BETWEEN PINS 4, 1
 $C2 = 10pF$ BETWEEN PINS 21, 24
 $C3 = 27pF$ BETWEEN PINS 9, 12

WIDEBAND NOISE $\cong 140\mu V_{RMS}$

1064 TA01

Gain vs Frequency

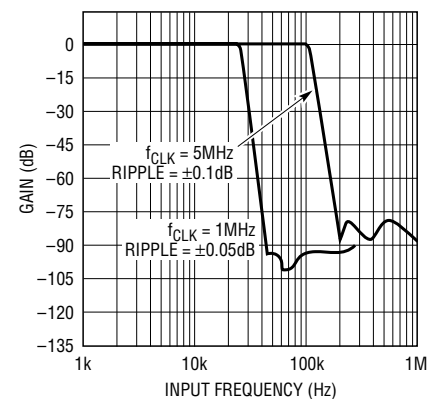

1064 TA02

LTC1064

ABSOLUTE MAXIMUM RATINGS (Note 1)

Total Supply Voltage (V^+ to V^-)	16V	Storage Temperature Range	-65°C to 150°C
Power Dissipation	500mW	Lead Temperature (Soldering, 10 sec)	300°C
Operating Temperature Range			
LTC1064AC/LTC1064C	-40°C to 85°C		
LTC1064AM			
LTC1064M (OBSOLETE)	-55°C to 125°C		

PACKAGE/ORDER INFORMATION

<p>N PACKAGE 24-LEAD PLASTIC DIP $T_{JMAX} = 110^{\circ}C, \theta_{JA} = 65^{\circ}C/W$</p>	<p>ORDER PART NUMBER</p> <p>LTC1064ACN LTC1064CN</p>	<p>SW PACKAGE 24-LEAD PLASTIC SO WIDE $T_{JMAX} = 100^{\circ}C, \theta_{JA} = 85^{\circ}C/W$</p>	<p>ORDER PART NUMBER</p> <p>LTC1064CSW</p>
<p>J PACKAGE 24-LEAD CERAMIC DIP $T_{JMAX} = 150^{\circ}C, \theta_{JA} = 100^{\circ}C/W$</p> <p>OBSOLETE PACKAGE Consider the 24-Lead N Package as an Alternate Source</p>	<p>LTC1064ACJ LTC1064CJ LTC1064AMJ LTC1064MJ</p>		
<p>Order Options Tape and Reel: Add #TR Lead Free: Add #PBF Lead Free Tape and Reel: Add #TRPBF Lead Free Part Marking: http://www.linear.com/leadfree/</p>			

Consult LTC Marketing for parts specified with wider operating temperature ranges.

ELECTRICAL CHARACTERISTICS (Internal Op Amps) The ● denotes the specifications which apply over the full operating temperature range, otherwise specifications are at $T_A = 25^{\circ}C$.

PARAMETER	CONDITIONS	MIN	TYP	MAX	UNITS
Operating Supply Voltage Range		±2.375		±8	V
Voltage Swings	$V_S = \pm 5V, R_L = 5k$	±3.2 ±3.1	±3.6		V
Output Short-Circuit Current (Source/Sink)	$V_S = \pm 5V$		3		mA
DC Open-Loop Gain	$V_S = \pm 5V, R_L = 5k$		80		dB
GBW Product	$V_S = \pm 5V$		7		MHz
Slew Rate	$V_S = \pm 5V$		10		V/μs

1064fb

ELECTRICAL CHARACTERISTICS (Complete Filter) The ● denotes the specifications which apply over the full operating temperature range, otherwise specifications are at $V_S = \pm 5V$, $T_A = 25^\circ C$, TTL clock input level, unless otherwise specified.

PARAMETER	CONDITIONS	MIN	TYP	MAX	UNITS		
Center Frequency Range, f_0	$V_S = \pm 8V$, $Q \leq 3$		0.1 to 140		kHz		
Input Frequency Range			0 to 1		MHz		
Clock-to-Center Frequency Ratio, f_{CLK}/f_0	LTC1064 LTC1064A (Note 2)	●	50 ± 0.3	50 ± 0.8	%		
				50 ± 0.9	%		
	LTC1064 LTC1064A (Note 2)	●	100 ± 0.3	100 ± 0.8	%		
				100 ± 0.9	%		
Clock-to-Center Frequency Ratio, Side-to-Side Matching	LTC1064 LTC1064A (Note 2)	●	0.4	1	%		
Clock-to-Center Frequency Ratio, f_{CLK}/f_0 (Note 3)	LTC1064 LTC1064A (Note 2)	●	50 ± 0.6	50 ± 1.3	%		
Q Accuracy	LTC1064 LTC1064 A (Note 2)	●	100 ± 0.6	100 ± 1.3	%		
Q Accuracy	Sides A, B, C: Mode 1, $Q = 10$ Side D: Mode 3, $f_{CLK} = 1MHz$	●		±2	6		
				±3	8		
f_0 Temperature Coefficient	Mode 1, 50:1, $f_{CLK} < 2MHz$		±1		ppm/°C		
Q Temperature Coefficient	Mode 1, 100:1, $f_{CLK} < 2MHz$ Mode 3, $f_{CLK} < 2MHz$	●		±5	ppm/°C		
				±5	ppm/°C		
DC Offset Voltage	V_{OS1} (Table 1)	●		2	15	mV	
	V_{OS2} (Table 1)	●		3	45	mV	
	V_{OS3} (Table 1)	●		3	45	mV	
Clock Feedthrough	$f_{CLK} < 1MHz$		0.2		mV _{RMS}		
Maximum Clock Frequency	Mode 1, $Q < 5$, $V_S \geq \pm 5V$		7		MHz		
Power Supply Current		●		9	12	23	mA
						26	mA

Note 1: Absolute Maximum Ratings are those values beyond which the life of a device may be impaired.

Note 2: Contact LTC Marketing.

Note 3: Not tested, guaranteed by design.

Table 1. Output DC Offsets, One 2nd Order Section

MODE	V_{OSN} PINS 2, 11, 14, 23	V_{OSBP} PINS 3, 10, 15, 22	V_{OSLP} PINS 4, 9, 16, 21
1	$V_{OS1} [(1/Q) + 1 + H_{OLP}] - V_{OS3}/Q$	V_{OS3}	$V_{OSN} - V_{OS2}$
1b	$V_{OS1} [(1/Q) + 1 + (R2/R1)] - V_{OS3}/Q$	V_{OS3}	$\sim (V_{OSN} - V_{OS2}) [1 + (R5/R6)]$
2	$V_{OS1} [(1 + (R2/R1) + (R2/R3) + (R2/R4) - V_{OS3}(R2/R3)) \times [R4/(R2 + R4)] + V_{OS2}[R2/(R2 + R4)]$	V_{OS3}	$V_{OSN} - V_{OS2}$
3	V_{OS2}	V_{OS3}	$V_{OS1} [1 + (R4/R1) + (R4/R2) + (R4/R3)] - V_{OS2}(R4/R2) - V_{OS3}(R4/R3)$

BLOCK DIAGRAM

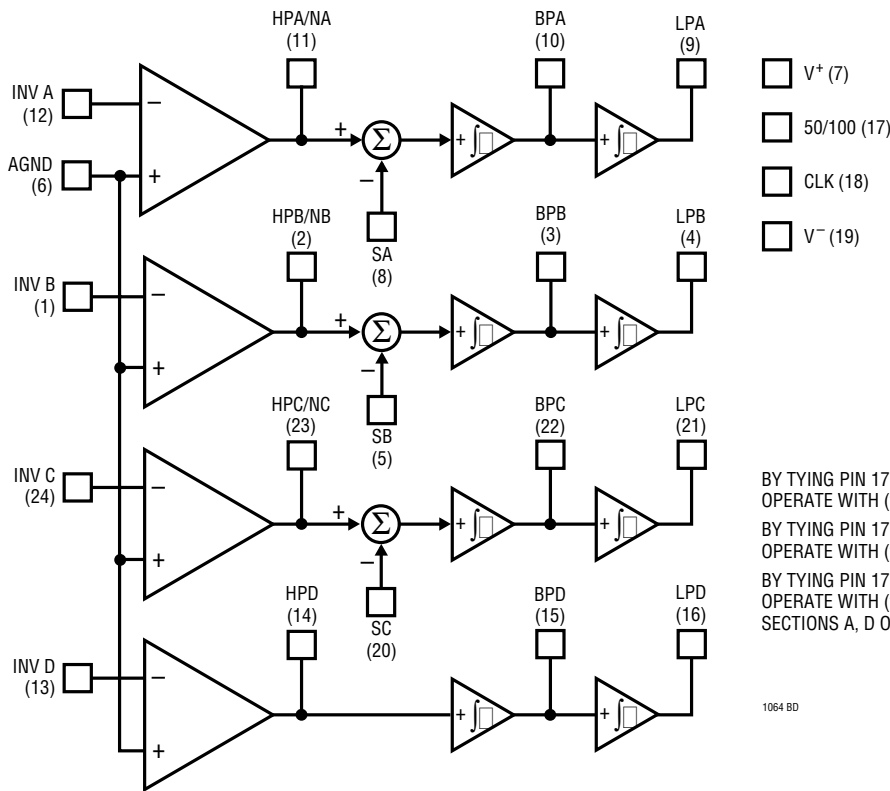

1064 BD

TYPICAL PERFORMANCE CHARACTERISTICS

Mode 1, (f_{CLK}/f₀) = 50:1

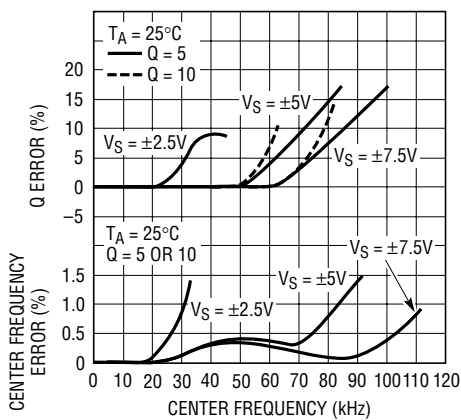

1064 G01

Mode 1, (f_{CLK}/f₀) = 100:1

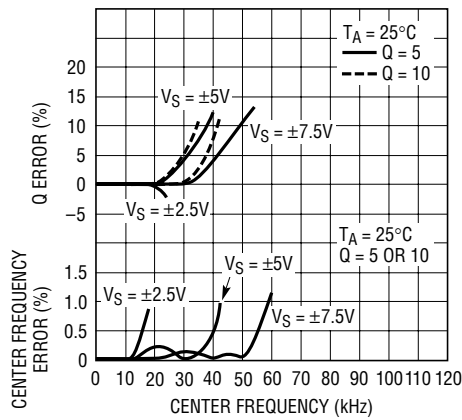

1064 G02

Mode 2, (f_{CLK}/f₀) = 25:1

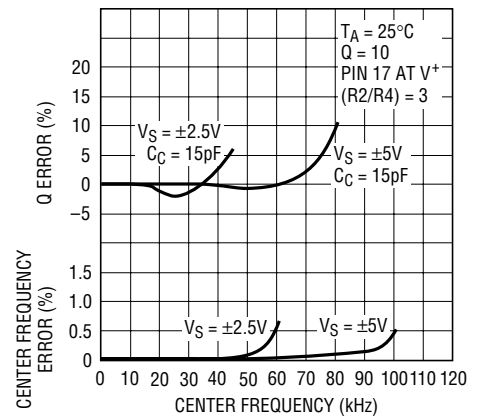

1064 G03

1064fb

TYPICAL PERFORMANCE CHARACTERISTICS

Mode 2, (f_{CLK}/f_0) = 25:1

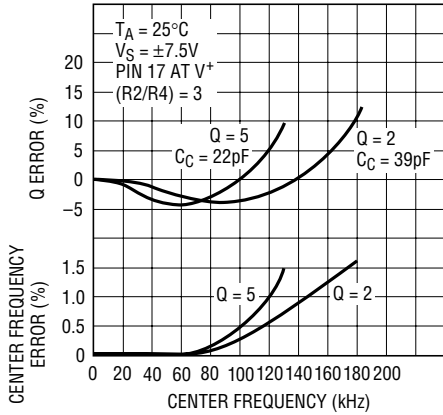

1064 G04

Mode 2, (f_{CLK}/f_0) = 50:1

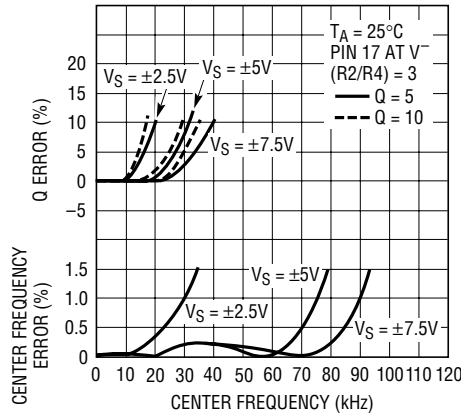

1064 G05

Mode 3, (f_{CLK}/f_0) = 50:1

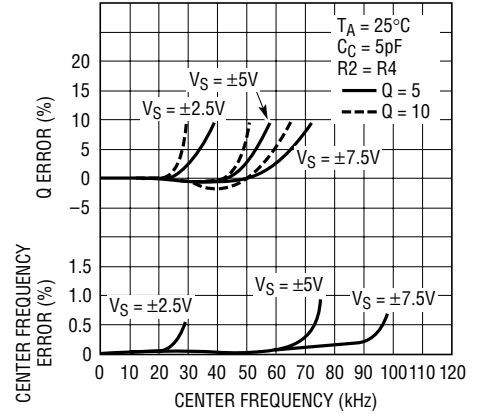

1064 G06

Mode 3, (f_{CLK}/f_0) = 50:1

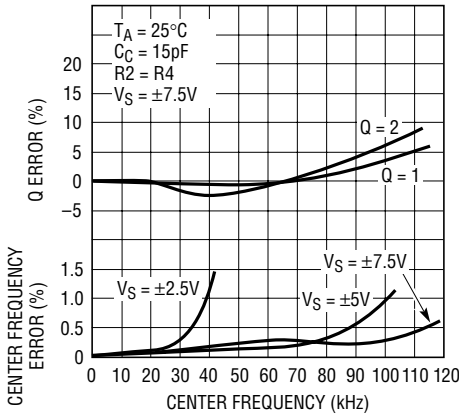

1064 G07

Mode 3, (f_{CLK}/f_0) = 100:1

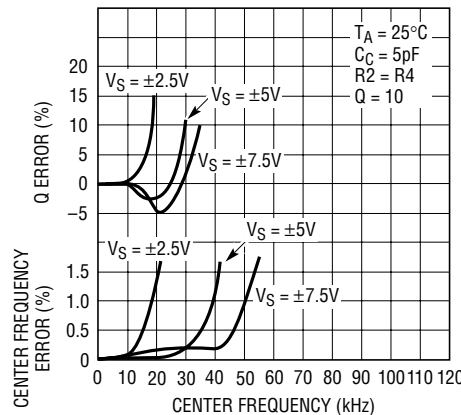

1064 G08

Wideband Noise vs Q

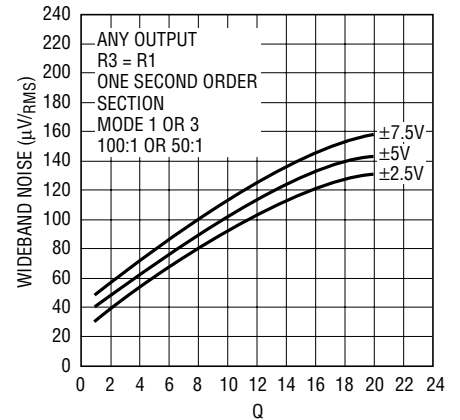

1064 G09

Power Supply Current vs Supply Voltage

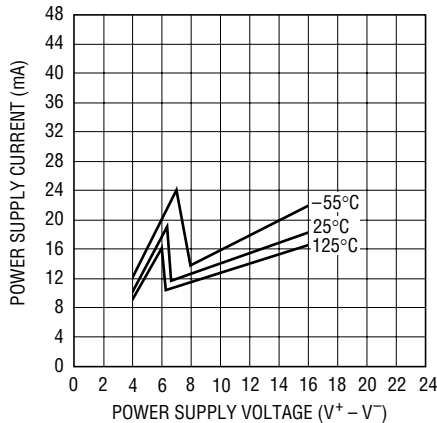

1064 G10

Harmonic Distortion, 8th Order LP Butterworth, $f_c = 20\text{kHz}$, THD = 0.015% for $3V_{RMS}$ Input

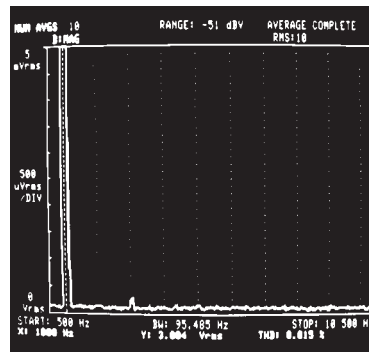

1064 G11

PIN FUNCTIONS

V⁺, V⁻ (Pins 7, 19): Power Supplies. They should be bypassed with a 0.1μF ceramic capacitor. Low noise, nonswitching power supplies are recommended. The device operates with a single 5V supply and with dual supplies. The absolute maximum operating power supply voltage is ±8V.

CLK (Pin 18): Clock. For ±5V supplies the logic threshold level is 1.4V. For ±8V and 0V to 5V supplies the logic threshold levels are 2.2V and 3V respectively. The logic threshold levels vary ±100mV over the full military temperature range. The recommended duty cycle of the input clock is 50%, although for clock frequencies below 500kHz, the clock “on” time can be as low as 200ns. The maximum clock frequency for ±5V supplies is 4MHz. For ±7V supplies and above, the maximum clock frequency is 7MHz.

AGND (Pin 6): Analog Ground. When the LTC1064 operates with dual supplies, Pin 6 should be tied to system ground. When the LTC1064 operates with a single positive supply, the analog ground pin should be tied to 1/2 supply and it should be bypassed with a 1μF solid tantalum in parallel with a 0.1μF ceramic capacitor, Figure 1. The positive input of all the internal op amps, as well as the common reference of all the internal switches, are internally tied to the analog ground pin. Because of this, a very “clean” ground is recommended.

50/100 (Pin 17): By tying Pin 17 to V⁺, all filter sections operate with a clock-to-center frequency ratio internally set at 50:1. When Pin 17 is at mid-supplies, sections B and C operate with (f_{CLK}/f₀) = 50:1 and sections A and D operate at 100:1. When Pin 17 is shorted to the negative supply pin, all filter sections operate with (f_{CLK}/f₀) = 100:1.

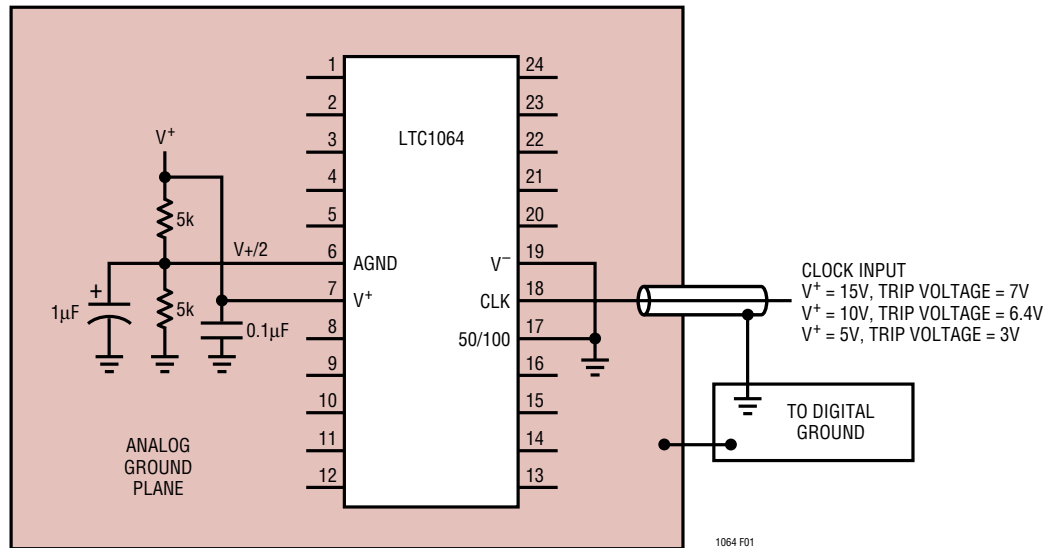

NOTE: PINS 5, 8, 20, IF NOT USED, SHOULD BE CONNECTED TO PIN 6

Figure 1. Single Supply Operation

APPLICATIONS INFORMATION

ANALOG CONSIDERATIONS

Grounding and Bypassing

The LTC1064 should be used with separated analog and digital ground planes and single point grounding techniques.

Pin 6 (AGND) should be tied directly to the analog ground plane.

Pin 7 (V^+) should be bypassed to the ground plane with a $0.1\mu\text{F}$ ceramic capacitor with leads as short as possible. Pin 19 (V^-) should be bypassed with a $0.1\mu\text{F}$ ceramic capacitor. For single supply applications, V^- can be tied to the analog ground plane.

For good noise performance, V^+ and V^- must be free of noise and ripple.

All analog inputs should be referenced directly to the single point ground. The clock inputs should be shielded from and/or routed away from the analog circuitry and a separate digital ground plane used.

Figure 2 shows an example of an ideal ground plane design for a 2-sided board. Of course this much ground plane will not always be possible, but users should strive to get as close to this as possible. Protoboards are not recommended.

Buffering the Filter Output

When driving coaxial cables and $1\times$ scope probes, the filter output should be buffered. This is important especially when high Q s are used to design a specific filter. *Inadequate buffering may cause errors in noise, distortion, Q and gain measurements.* When $10\times$ probes are used, buffering is usually not required. An inverting buffer is recommended especially when THD tests are performed. As shown in Figure 3, the buffer should be adequately bypassed to minimize clock feedthrough.

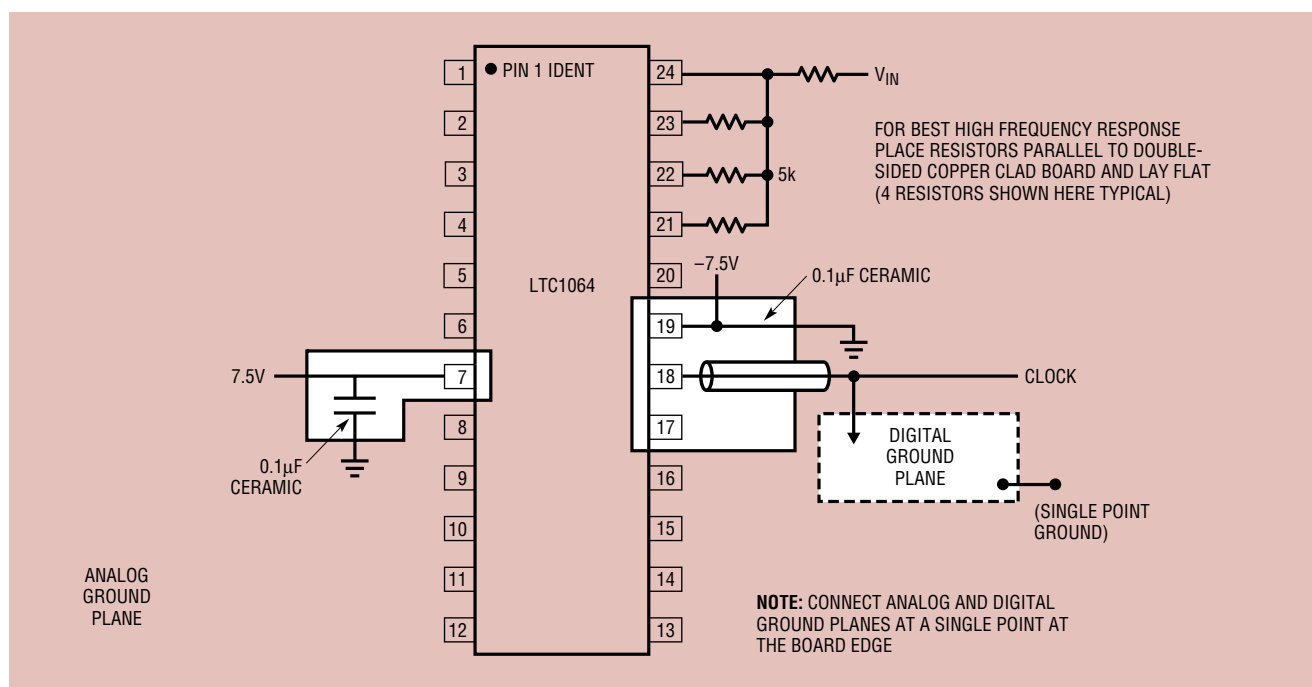

1064 F02

Figure 2. Example Ground Plane Breadboard Technique for LTC1064

APPLICATIONS INFORMATION

Offset Nulling

Lowpass filters may have too much DC offset for some users. A servo circuit may be used to actively null the offsets of the LTC1064 or any LTC switched-capacitor filter. The circuit shown in Figure 4 will null offsets to better than 300µV. This circuit takes seconds to settle because of the integrator pole frequency.

Noise

All the noise performance mentioned excludes the clock feedthrough. Noise measurements will degrade if the already described grounding bypassing and buffering techniques are not practiced. The graph Wideband Noise vs Q in the Typical Performance Characteristics section is a very good representation of the noise performance of this device.

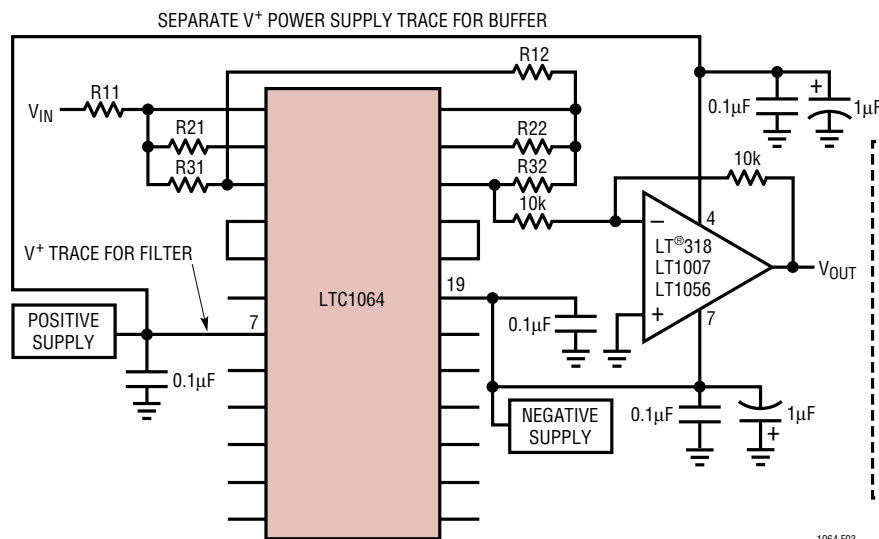

Figure 3. Buffering the Output of a 4th Order Bandpass Realization

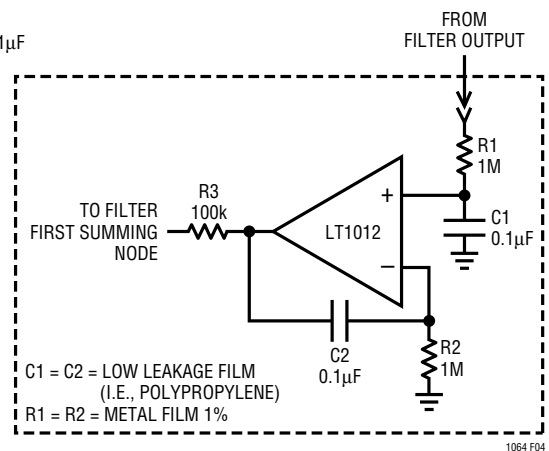

Figure 4. Servo Amplifier

MODES OF OPERATION

PRIMARY MODES

Mode 1

In Mode 1, the ratio of the external clock frequency to the center frequency of each 2nd order section is internally fixed at 50:1 or 100:1. Figure 5 illustrates Mode 1 providing 2nd order notch, lowpass and bandpass outputs. Mode 1 can be used to make high order Butterworth lowpass filters; it can also be used to make low Q notches and for cascading 2nd order bandpass functions tuned at the same center frequency with unity gain. Mode 1 is faster than Mode 3. Note that Mode 1 can only be implemented with three of the four LTC1064 sections because Section D has no externally available summing node. Section D, however, can be internally connected in Mode 1 upon special request.

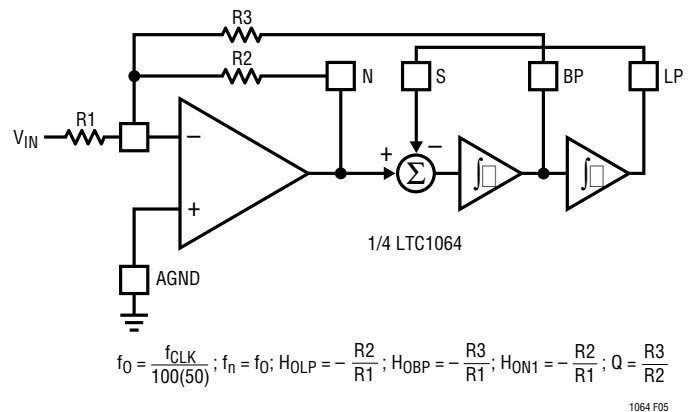

Figure 5. Mode 1: 2nd Order Filter Providing Notch, Bandpass and Lowpass

MODES OF OPERATION

Mode 3

Mode 3 is the second of the primary modes. In Mode 3, the ratio of the external clock frequency to the center frequency of each 2nd order section can be adjusted above or below 50:1 or 100:1. Side D of the LTC1064 can only be connected in Mode 3. Figure 6 illustrates Mode 3, the classical state variable configuration, providing highpass, bandpass and lowpass 2nd order filter functions. Mode 3 is slower than Mode 1. Mode 3 can be used to make high order all-pole bandpass, lowpass, highpass and notch filters.

When the internal clock-to-center frequency ratio is set at 50:1, the design equations for Q and bandpass gain are different from the 100:1 case. This was done to provide speed without penalizing the noise performance.

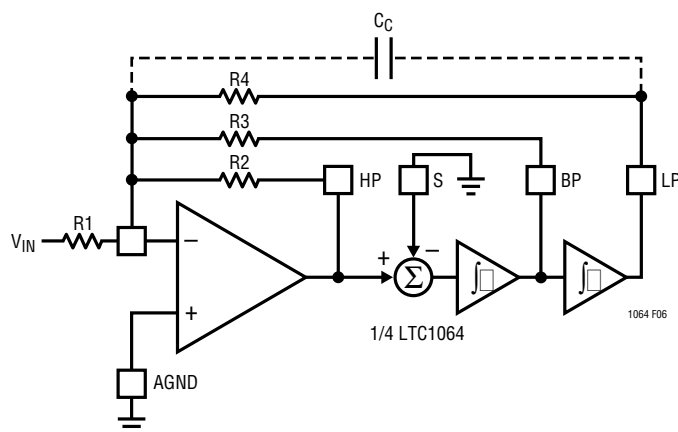

$$\text{MODE 3 (100:1): } f_0 = \frac{f_{\text{CLK}}}{100} \sqrt{\frac{R_2}{R_4}}; Q = \frac{R_3}{R_2} \sqrt{\frac{R_2}{R_4}}; H_{\text{OHP}} = -\frac{R_2}{R_1};$$

$$H_{\text{OBP}} = -\frac{R_3}{R_1}; H_{\text{OLP}} = -\frac{R_4}{R_1}$$

$$\text{MODE 3 (50:1): } f_0 = \frac{f_{\text{CLK}}}{50} \sqrt{\frac{R_2}{R_4}}; Q = \frac{1.005 \sqrt{R_4}}{\frac{R_2}{R_3} - \frac{R_2}{16R_4}};$$

$$H_{\text{OHP}} = -\frac{R_2}{R_1}; H_{\text{OBP}} = -\frac{R_3}{1 - \frac{R_3}{16R_4}}; H_{\text{OLP}} = -\frac{R_4}{R_1}$$

NOTE: THE 50:1 EQUATIONS FOR MODE 3 ARE DIFFERENT FROM THE EQUATIONS FOR MODE 3 OPERATIONS OF THE LTC1059, LTC1060 AND LTC1061. START WITH f_0 , CALCULATE R_2/R_4 , SET R_4 ; FROM THE Q VALUE, CALCULATE R_3 :

$$R_3 = \frac{R_2}{\frac{1.005 \sqrt{R_2}}{Q} + \frac{R_2}{16R_4}}; \text{ THEN CALCULATE } R_1 \text{ TO SET THE DESIRED GAIN.}$$

1064 F06 Eq

Figure 6. Mode 3: 2nd Order Filter Providing Highpass, Bandpass and Lowpass

SECONDARY MODES

Mode 1b

Mode 1b is derived from Mode 1. In Mode 1b, Figure 7, two additional resistors R5 and R6 are added to alternate the amount of voltage fed back from the lowpass output into the input of the SA (or SB or SC) switched-capacitor summer. This allows the filter's clock-to-center frequency ratio to be adjusted beyond 50:1 or 100:1. Mode 1b maintains the speed advantages of Mode 1.

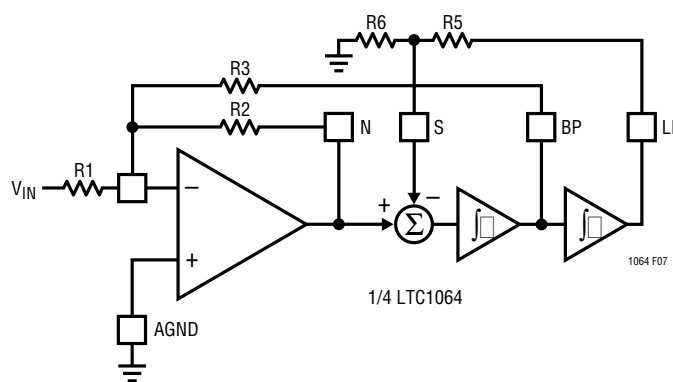

$$f_0 = \frac{f_{\text{CLK}}}{100(50)} \sqrt{\frac{R_6}{R_5 + R_6}}; f_n = f_0; Q = \frac{R_3}{R_2} \sqrt{\frac{R_6}{R_5 + R_6}};$$

$$H_{\text{ON1}}(f \rightarrow 0) = H_{\text{ON2}}\left(f \rightarrow \frac{f_{\text{CLK}}}{2}\right) \frac{R_2}{R_1} H_{\text{OLP}} = -\frac{R_2}{R_5 + R_6} \frac{R_1}{R_6}$$

$$H_{\text{OBP}} = -\frac{R_3}{R_1}; R_5 || R_6 \leq 5k$$

1064 F07 Eq

Figure 7. Mode 1b: 2nd Order Filter Providing Notch, Bandpass and Lowpass

Mode 2

Mode 2 is a combination of Mode 1 and Mode 3, as shown in Figure 8. With Mode 2, the clock-to-center frequency ratio f_{CLK}/f_0 is always less than 50:1 or 100:1. The advantage of Mode 2 is that it provides less sensitivity to resistor tolerances than does Mode 3. As in Mode 1, Mode 2 has a notch output which depends on the clock frequency and the notch frequency is therefore less than the center frequency f_0 .

When the internal clock-to-center frequency ratio is set at 50:1, the design equations for Q and bandpass gain are different from the 100:1 case.

MODES OF OPERATION

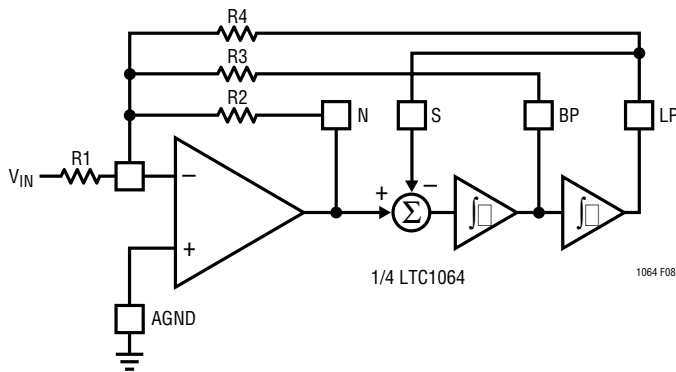

MODE 2 (100:1): $f_0 = \frac{f_{CLK}}{100} \sqrt{1 + \frac{R_2}{R_4}}$; $f_n = \frac{f_{CLK}}{50}$; $Q = \frac{R_3}{R_2} \sqrt{1 + \frac{R_2}{R_4}}$; $H_{OLP} = -\frac{\frac{R_2}{R_1}}{1 + \frac{R_2}{R_4}}$

$H_{OBP} = -\frac{R_3}{R_1}$; $H_{ON1}(f \rightarrow 0) = -\frac{\frac{R_2}{R_1}}{1 + \frac{R_2}{R_4}}$; $H_{ON2}\left(f \rightarrow \frac{f_{CLK}}{2}\right) = \frac{R_2}{R_1}$

MODE 2 (50:1): $f_0 = \frac{f_{CLK}}{50} \sqrt{1 + \frac{R_2}{R_4}}$; $f_n = \frac{f_{CLK}}{50}$; $Q = \frac{1.005 \sqrt{1 + \frac{R_2}{R_4}}}{\frac{R_2}{R_3} - \frac{R_2}{16R_4}}$; $H_{OLP} = -\frac{\frac{R_2}{R_1}}{1 + \frac{R_2}{R_4}}$

$H_{OBP} = -\frac{\frac{R_3}{R_1}}{1 - \frac{R_2}{16R_4}}$; $H_{ON1}(f \rightarrow 0) = -\frac{\frac{R_2}{R_1}}{1 + \frac{R_2}{R_4}}$; $H_{ON2} = \left(f \rightarrow \frac{f_{CLK}}{2}\right) = \frac{R_2}{R_1}$

NOTE: THE 50:1 EQUATIONS FOR MODE 2 ARE DIFFERENT FROM THE EQUATIONS FOR MODE 2 OPERATION OF THE LTC1059, LTC1060 AND LTC1061. START WITH f_0 , CALCULATE R_2/R_4 , SET R_4 ; FROM THE Q VALUE, CALCULATE R_3 :

$$R_3 = \frac{R_2}{\frac{1.005}{Q} \sqrt{1 + \frac{R_2}{R_4}} + \frac{R_2}{16R_4}}$$

1064 F08Eq

Figure 8. Mode 2: 2nd Order Filter Providing Notch, Bandpass and Lowpass

Mode 3a

This is an extension of Mode 3 where the highpass and lowpass outputs are summed through two external resistors R_H and R_L to create a notch. This is shown in Figure 9. Mode 3a is more versatile than Mode 2 because the notch frequency can be higher or lower than the center frequency of the 2nd order section. The external op amp of Figure 9 is not always required. When cascading the sections of the LTC1064, the highpass and lowpass

outputs can be summed directly into the inverting input of the next section. The topology of Mode 3a is useful for elliptic highpass and notch filters with clock-to-cutoff frequency ratios higher than 100:1. This is often required to extend the allowed input signal frequency range and to avoid premature aliasing.

When the internal clock-to-center frequency ratio is set at 50:1, the design equations for Q and bandpass gain are different from the 100:1 case.

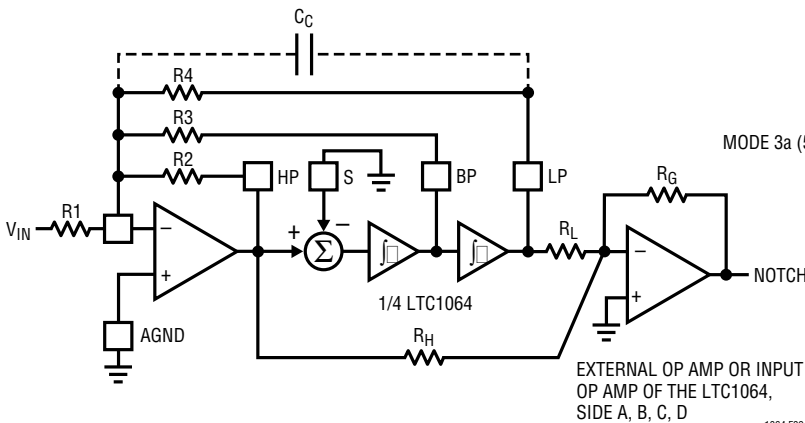

MODE 3a (100:1): $f_0 = \frac{f_{CLK}}{100} \sqrt{\frac{R_2}{R_4}}$; $f_n = \frac{f_{CLK}}{100} \sqrt{\frac{R_H}{R_L}}$; $H_{OHP} = -\frac{R_2}{R_1}$; $H_{OBP} = -\frac{R_3}{R_1}$

$H_{OLP} = -\frac{R_4}{R_1}$; $H_{ON1}(f \rightarrow 0) = \left(\frac{R_G}{R_L}\right)\left(\frac{R_4}{R_1}\right)$; $H_{ON2}\left(f \rightarrow \frac{f_{CLK}}{2}\right) = \left(\frac{R_G}{R_H}\right)\left(\frac{R_2}{R_1}\right)$

$H_{ON}(f=f_0) = Q \left(\frac{R_G H_{OLP}}{R_L} - \frac{R_G H_{OHP}}{R_H}\right)$; $Q = \frac{R_3}{R_2} \sqrt{\frac{R_2}{R_4}}$

MODE 3a (50:1): $f_0 = \frac{f_{CLK}}{50} \sqrt{1 + \frac{R_2}{R_4}}$; $f_n = \frac{f_{CLK}}{50} \sqrt{\frac{R_H}{R_L}}$; $H_{OHP}\left(f \rightarrow \frac{f_{CLK}}{2}\right) = -\frac{R_2}{R_1}$

$H_{OBP} = -\frac{\frac{R_3}{R_1}}{1 - \frac{R_3}{16R_4}}$; $H_{OLP}(f=0) = -\frac{R_4}{R_1}$; $Q = \frac{1.005 \sqrt{\frac{R_2}{R_4}}}{\frac{R_2}{R_3} - \frac{R_2}{16R_4}}$

NOTE: THE 50:1 EQUATIONS FOR MODE 3A ARE DIFFERENT FROM THE EQUATIONS FOR MODE 3A OPERATION OF THE LTC1059, LTC1060 AND LTC1061. START WITH f_0 , CALCULATE R_2/R_4 , SET R_4 ; FROM THE Q VALUE, CALCULATE R_3 :

$$R_3 = \frac{R_2}{\frac{1.005}{Q} \sqrt{\frac{R_2}{R_4}} + \frac{R_2}{16R_4}}$$

1064 F09Eq

Figure 9. Mode 3a: 2nd Order Filter Providing Highpass, Bandpass, Lowpass and Notch

1064fb

TYPICAL APPLICATIONS

Wideband Bandpass: Ratio of High to Low Corner Frequency Equal to 2

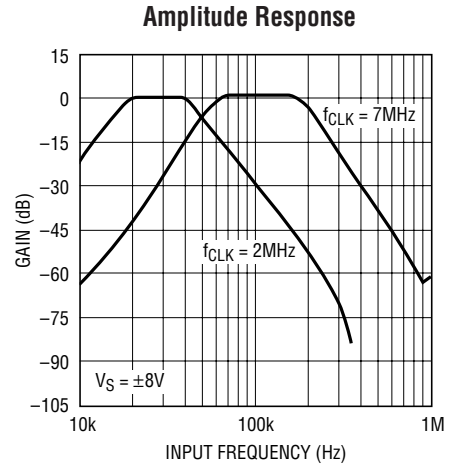
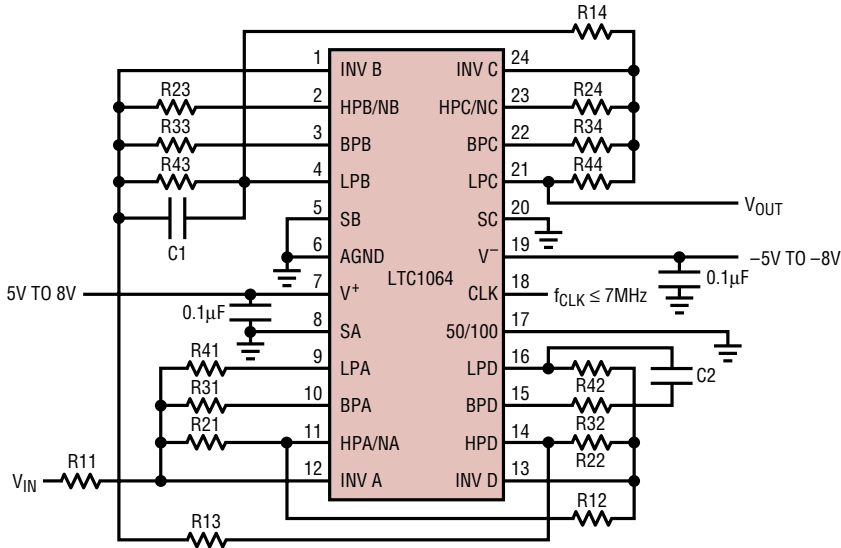

RESISTOR VALUES:

- R11 = 16k R21 = 16k R31 = 7.32k R41 = 10k
- R12 = 10k R22 = 10k R32 = 22.6k R42 = 13.3k
- R13 = 23.2k R23 = 13.3k R33 = 21.5k R43 = 10k
- R14 = 6.8k R24 = 20k R34 = 15.4k R44 = 32.4k

NOTE: FOR $f_{CLK} \geq 3\text{MHz}$, USE $C1 = C2 = 22\text{pF}$

1064 TA03

Quad Bandpass Filter with Center Frequency Equal to f_0 , $2f_0$, $3f_0$ and $4f_0$

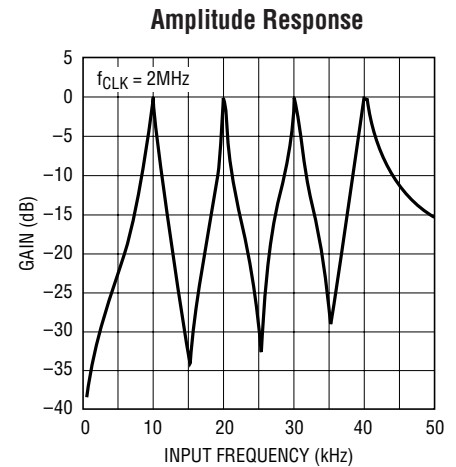
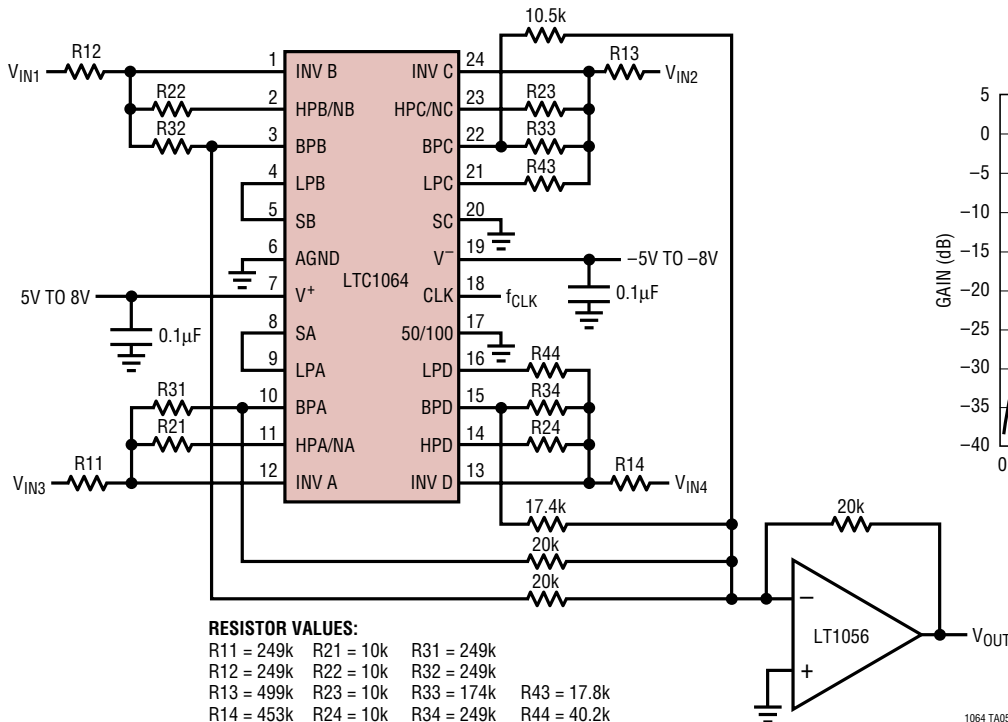

RESISTOR VALUES:

- R11 = 249k R21 = 10k R31 = 249k
- R12 = 249k R22 = 10k R32 = 249k
- R13 = 499k R23 = 10k R33 = 174k R43 = 17.8k
- R14 = 453k R24 = 10k R34 = 249k R44 = 40.2k

1064 TA05

TYPICAL APPLICATIONS

8th Order Bandpass Filter with 2 Stopband Notches

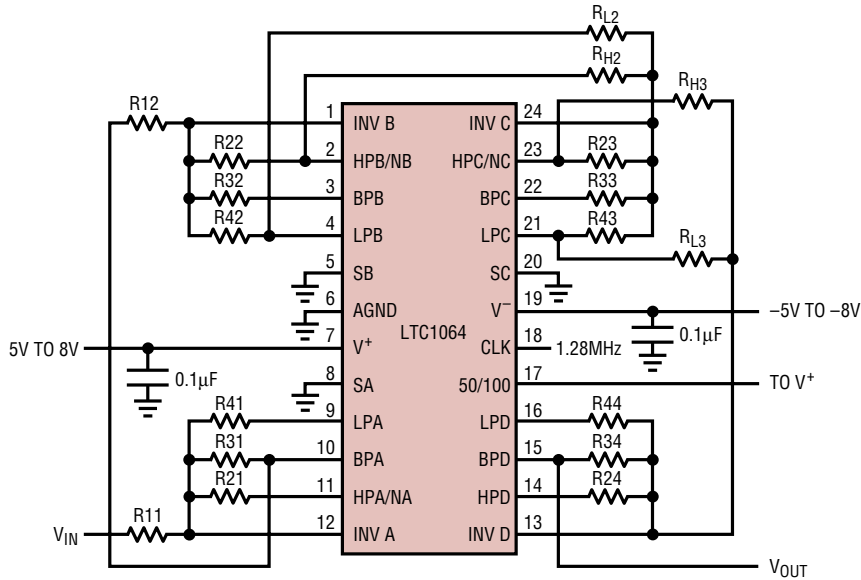

RESISTOR VALUES:

R11 = 46.95k	R21 = 10k	R31 = 38.25k	R41 = 11.81k		
R12 = 93.93k	R22 = 10k	R32 = 81.5k	R42 = 14.72k	R _{L2} = 27.46k	R _{H2} = 6.9k
		R23 = 16.3k	R33 = 70.3k	R43 = 10k	R _{L3} = 17.9k
		R24 = 13.19k	R34 = 39.42k	R44 = 10.5k	R _{H3} = 69.7k

NOTE 1: THE V⁺, V⁻ PINS SHOULD BE BYPASSED WITH A 0.1µF TO 0.22µF CERAMIC CAPACITOR, RIGHT AT THE PINS.

NOTE 2: THE RATIOS OF ALL (R2/R4) RESISTORS SHOULD BE MATCHED TO BETTER THAN 0.25%. THE REMAINING RESISTORS SHOULD BE BETTER THAN 0.5% ACCURATE.

1064 TA07

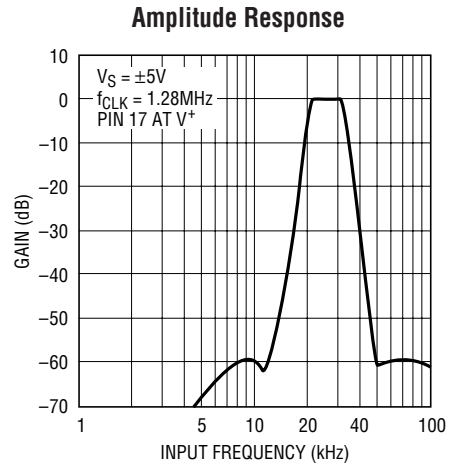

1064 TA08

C-Message Filter

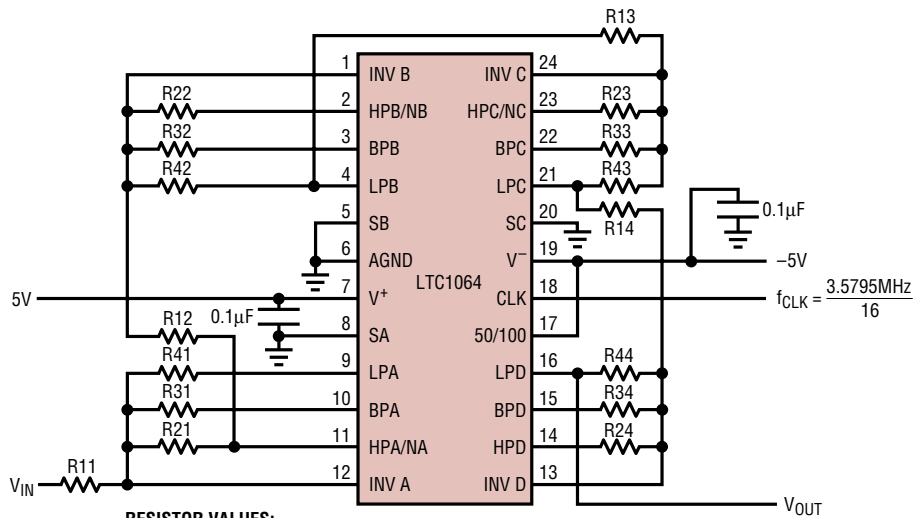

RESISTOR VALUES:

R11 = 88.7k	R21 = 10k	R31 = 35.7k	R41 = 88.7k
R12 = 10k	R22 = 44.8k	R32 = 33.2k	R42 = 24.9k
R13 = 15.8k	R23 = 48.9k	R33 = 63.5k	R43 = 25.5k
R14 = 15.8k	R24 = 44.8k	R34 = 16.5k	R44 = 24.9k

1064 TA09

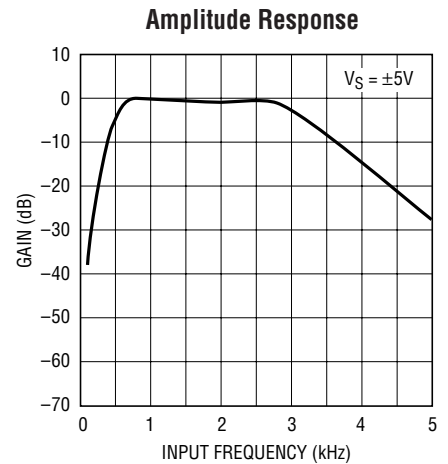

1064 TA10

TYPICAL APPLICATIONS

8th Order Chebyshev Lowpass Filter with a Passband Ripple of 0.1dB and Cutoff Frequency up to 100kHz

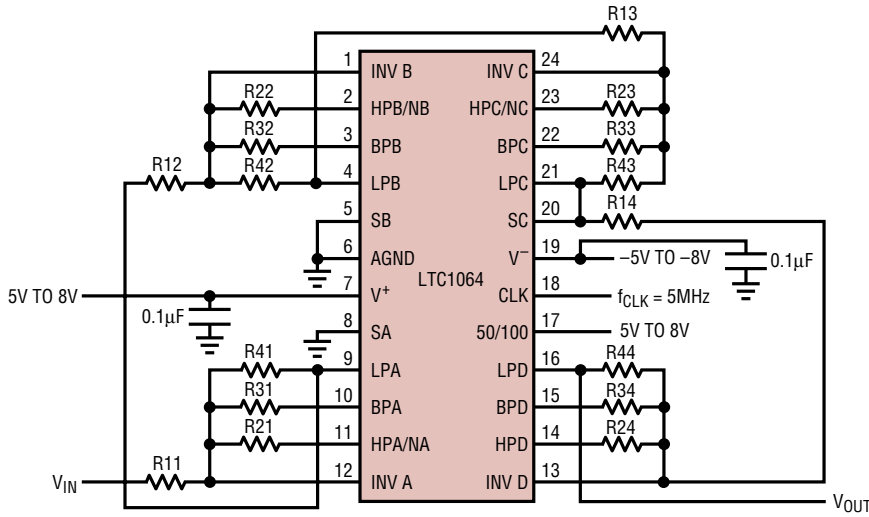

RESISTOR VALUES:

R11 = 100.86k	R21 = 16.75k	R31 = 23.6k	R41 = 99.73k
R12 = 25.72k	R22 = 20.93k	R32 = 45.2k	R42 = 25.52k
R13 = 16.61k	R23 = 10.18k	R33 = 68.15k	R43 = 99.83k
R14 = 13.84k	R24 = 11.52k	R34 = 17.72k	R44 = 25.42k

1064 TA11

FOR $f_{CLK} > 3\text{MHz}$, ADD $C2 = 10\text{pF}$ ACROSS $R42$
 $C3 = 10\text{pF}$ ACROSS $R43$
 $C4 = 10\text{pF}$ ACROSS $R44$

WIDEBAND NOISE = $170\mu\text{VRMS}$

Amplitude Response

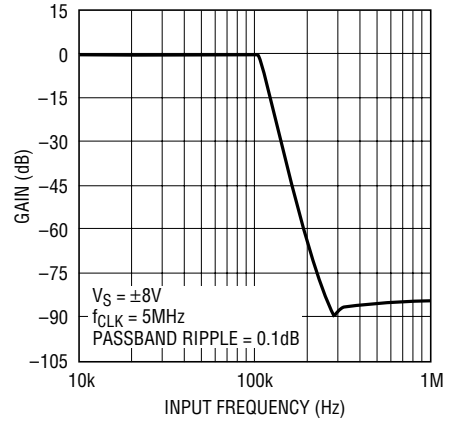

1064 TA12

TYPICAL APPLICATIONS

8th Order Clock-Sweepable Lowpass Elliptic Antialiasing Filter

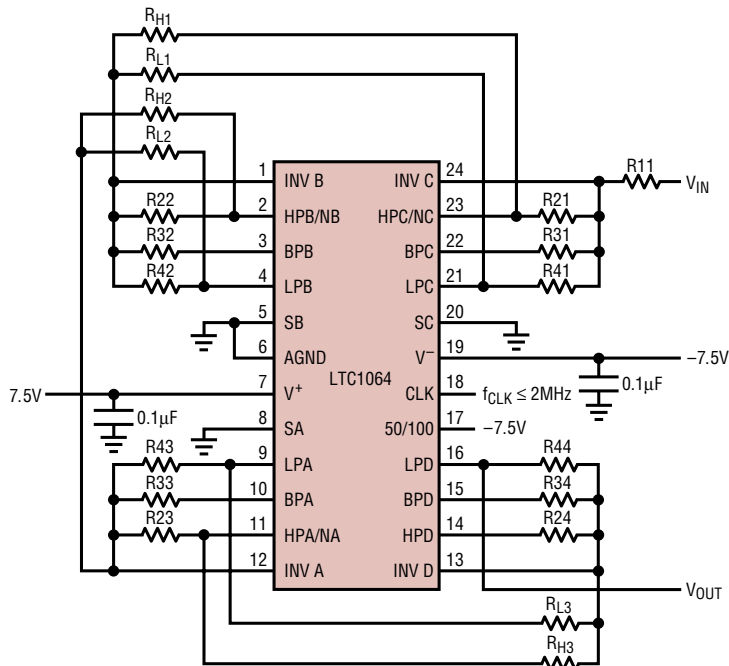

RESISTOR VALUES:

R11 = 19.1k	R21 = 10k	R31 = 13.7k	R41 = 15.4k	RL1 = 14k	RH1 = 30.9k
	R22 = 10k	R32 = 23.7k	R42 = 10.2k	RL2 = 26.7k	RH2 = 76.8k
	R23 = 11.3k	R33 = 84.5k	R43 = 10k	RL3 = 10k	RH3 = 60.2k
	R24 = 15.4k	R34 = 15.2k	R44 = 42.7k		

NOTE: FOR $f_{CUTOFF} > 15kHz$, ADD A 5pF CAPACITOR ACROSS R41 AND R43

1064 TA13

Amplitude Response

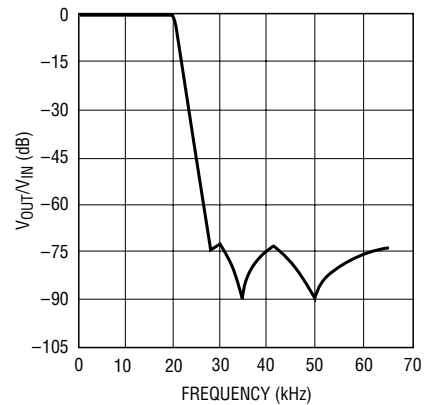

8TH ORDER CLOCK-SWEEPABLE LOWPASS ELLIPTIC ANTIALIASING FILTER MAINTAINS, FOR $0.1Hz \leq f_{CUTOFF} \leq 20kHz$, A $\pm 0.1dB$ MAX PASSBAND ERROR AND 72dB MIN STOPBAND ATTENUATION AT $1.5 \times f_{CUTOFF}$
 TOTAL WIDEBAND NOISE = $150\mu V_{RMS}$
 THD = 70dB (0.03%) FOR $V_{IN} = 3V_{RMS}$
 $f_{CLK}/f_{CUTOFF} = 100:1$. THIS FILTER AVAILABLE AS LTC1064-1 WITH INTERNAL THIN FILM RESISTORS

1064 TA14

TYPICAL APPLICATIONS

Dual 4th Order Bessel Filter with 140kHz Cutoff Frequency

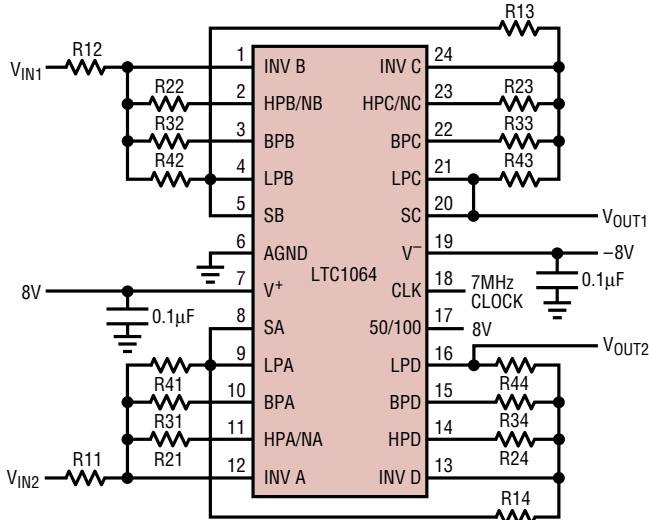

RESISTOR VALUES:

R11 = 14.3k	R21 = 13k	R31 = 7.5k	R41 = 10k
R12 = 15.4k	R22 = 15.4k	R32 = 7.5k	R42 = 10k
R13 = 3.92k	R23 = 20k	R33 = 27.4k	R43 = 40k
R14 = 3.92k	R24 = 20k	R34 = 6.8k	R44 = 10k

WIDEBAND NOISE = 64µVRMS

1064 TA15

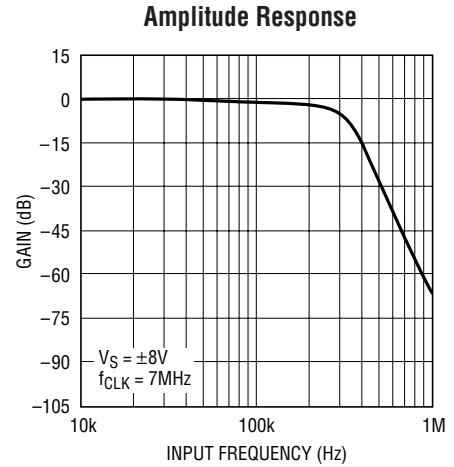

1064 TA16

8th Order Linear Phase (Bessel) Filter with $\frac{f_{CLK}}{f_{-3dB}} = 65$

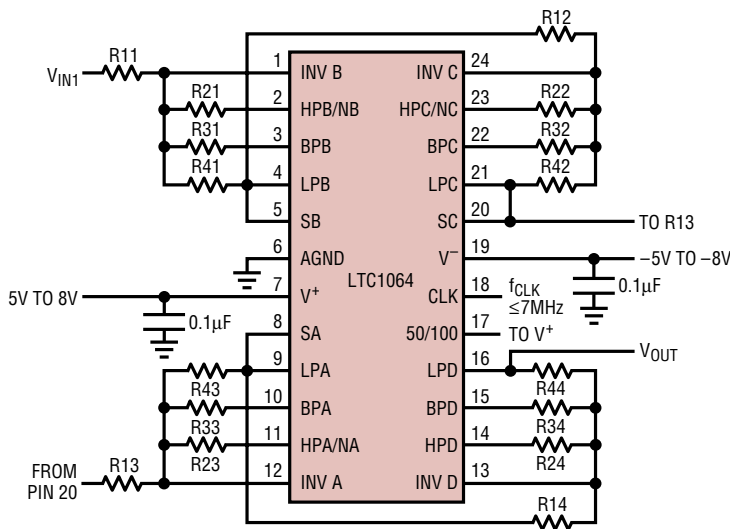

RESISTOR VALUES:

R11 = 34.8k	R21 = 34.8k	R31 = 14.3k	R41 = 40.2k
R12 = 10.5k	R22 = 45.3k	R32 = 22.1k	R42 = 39.2k
R13 = 12.7k	R23 = 34.8k	R33 = 24.3k	R43 = 20k
R14 = 20k	R24 = 34.8k	R34 = 13.3k	R44 = 20k

WIDEBAND NOISE = 70µVRMS

1064 TA17

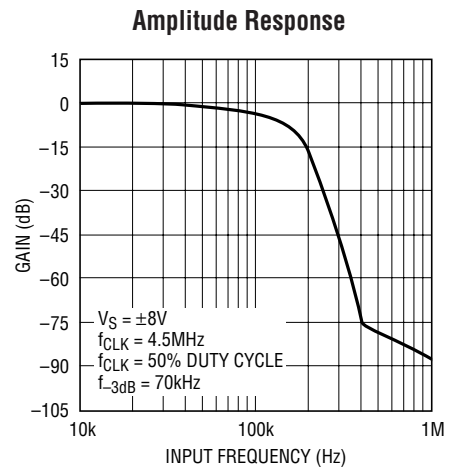

1064 TA18

TYPICAL APPLICATIONS

Dual 5th Order Chebyshev Lowpass Filter with 50kHz and 100kHz Cutoff Frequencies

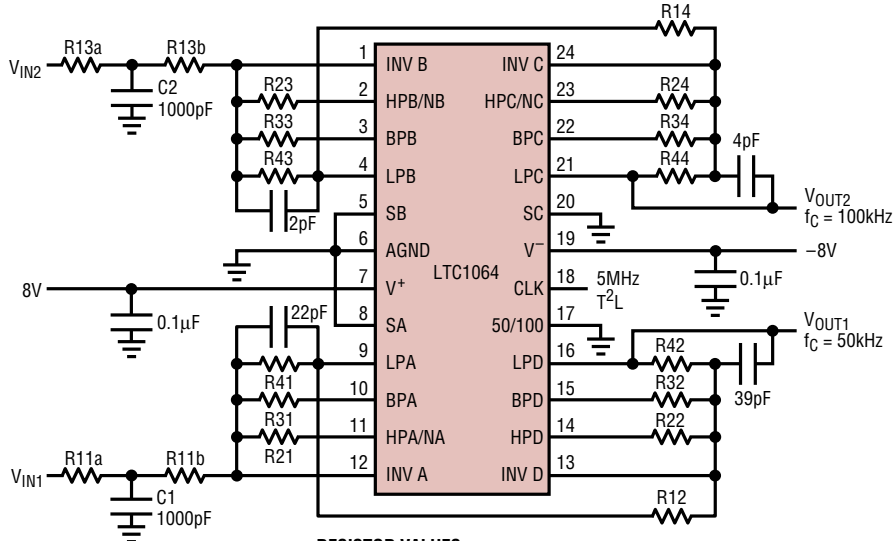

RESISTOR VALUES:

R11a = 4.32k	R21 = 11.8k	R31 = 29.4k	R41 = 10k
R11b = 27.4k	R22 = 20k	R32 = 21.5k	R42 = 31.6k
R12 = 10.5k	R23 = 11.8k	R33 = 29.4k	R43 = 10k
R13a = 3k	R24 = 20k	R34 = 21.6k	R44 = 31.6k
R13b = 29.4k			
R14 = 10.5k			

1064 TA19

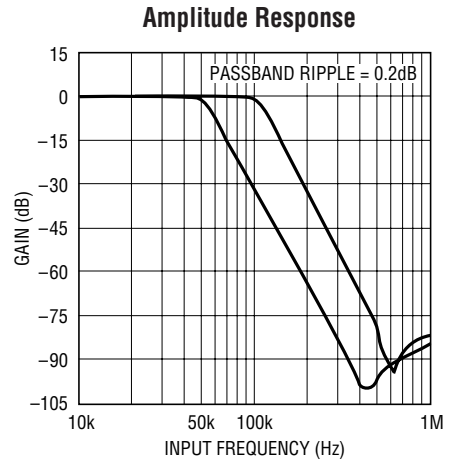

1064 TA20

PACKAGE DESCRIPTION

J Package
24-Lead CERDIP (Narrow .300 Inch, Hermetic)
(Reference LTC DWG # 05-08-1110)

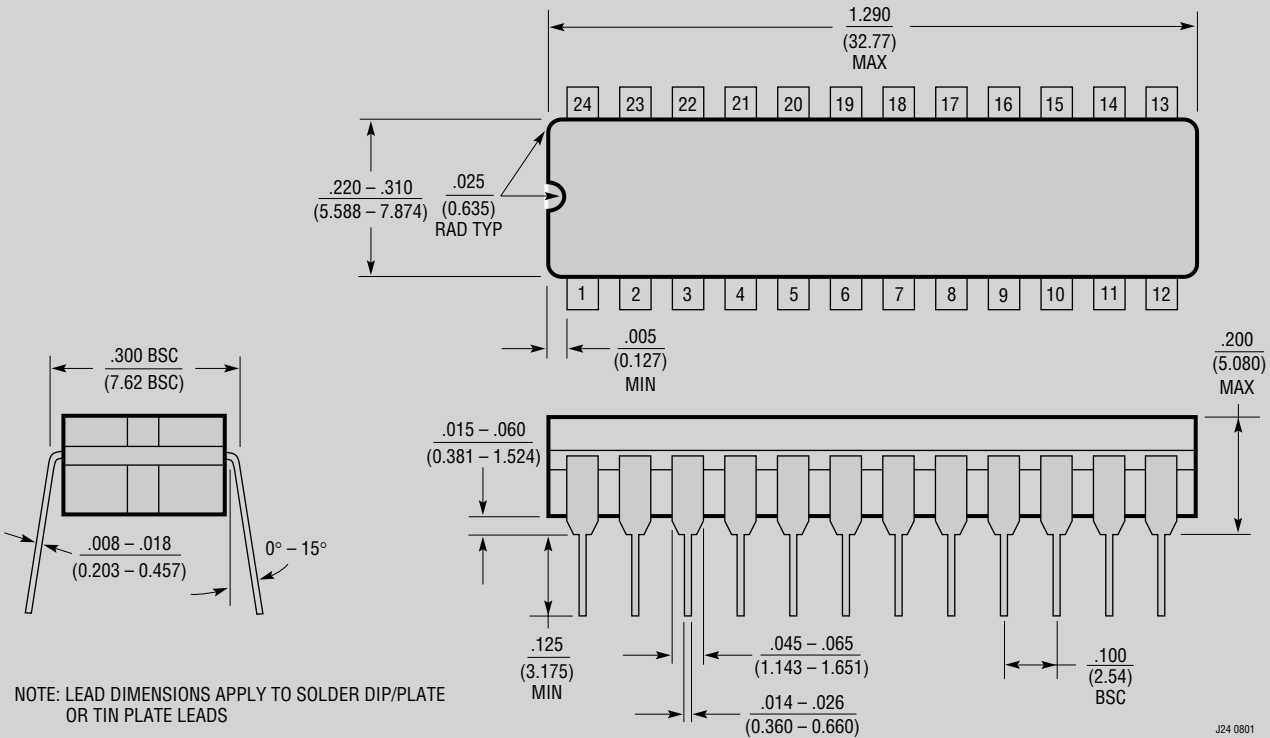

J24 0801

OBsolete PACKAGE

PACKAGE DESCRIPTION

N Package
24-Lead PDIP (Narrow .300 Inch)
 (Reference LTC DWG # 05-08-1510)

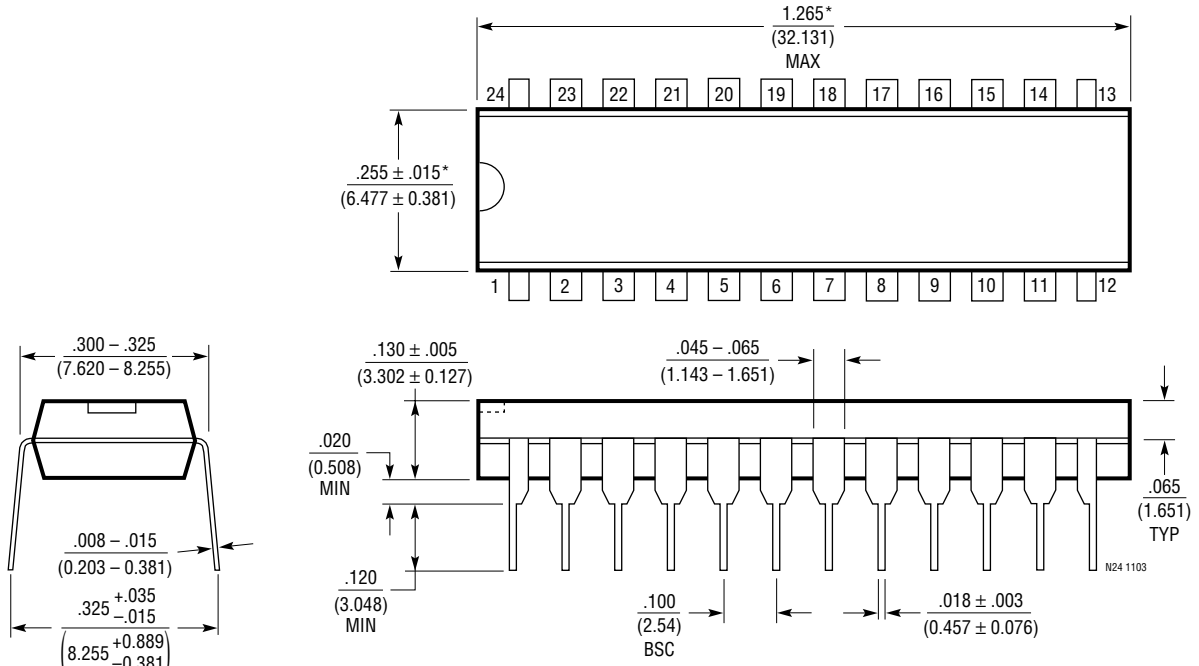

NOTE:
 1. DIMENSIONS ARE $\frac{\text{INCHES}}{\text{MILLIMETERS}}$
 *THESE DIMENSIONS DO NOT INCLUDE MOLD FLASH OR PROTRUSIONS.
 MOLD FLASH OR PROTRUSIONS SHALL NOT EXCEED .010 INCH (0.254mm)

PACKAGE DESCRIPTION

SW Package
24-Lead Plastic Small Outline (Wide .300 Inch)
 (Reference LTC DWG # 05-08-1620)

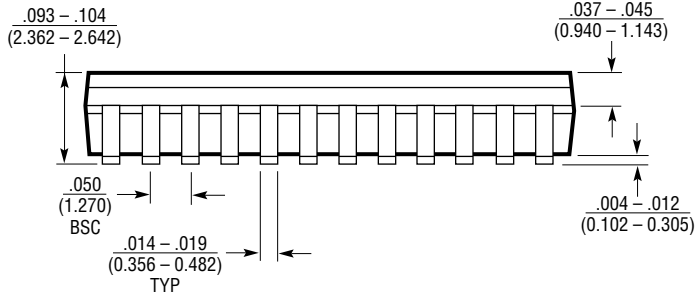
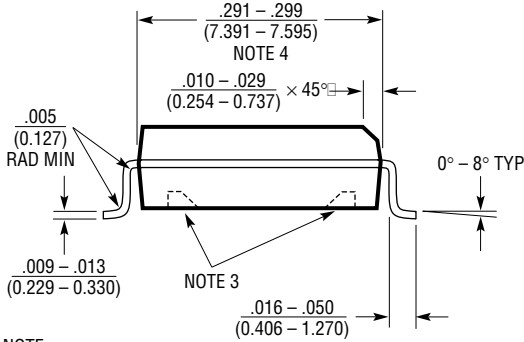
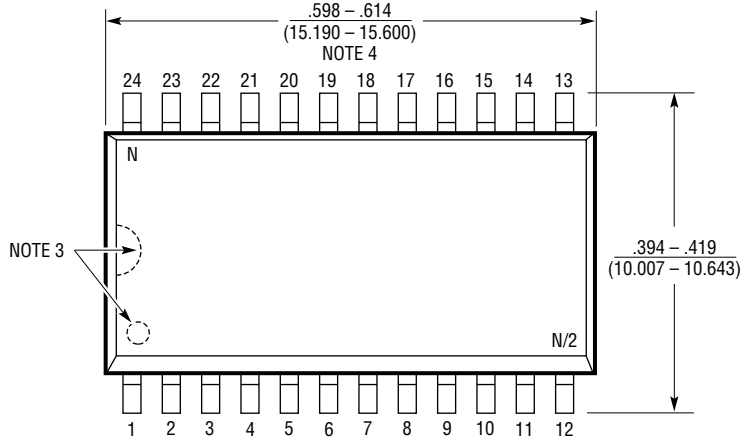
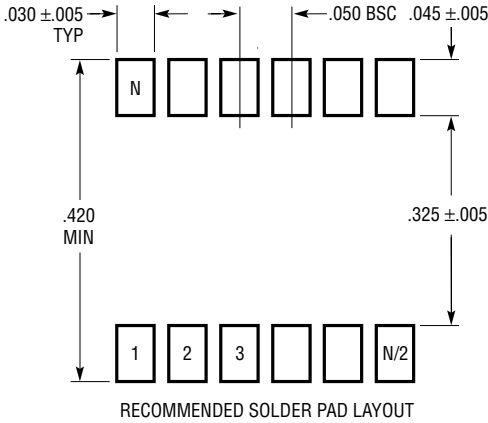

- NOTE:
1. DIMENSIONS IN $\frac{\text{INCHES}}{\text{MILLIMETERS}}$
 2. DRAWING NOT TO SCALE
 3. PIN 1 IDENT, NOTCH ON TOP AND CAVITIES ON THE BOTTOM OF PACKAGES ARE THE MANUFACTURING OPTIONS. THE PART MAY BE SUPPLIED WITH OR WITHOUT ANY OF THE OPTIONS
 4. THESE DIMENSIONS DO NOT INCLUDE MOLD FLASH OR PROTRUSIONS. MOLD FLASH OR PROTRUSIONS SHALL NOT EXCEED .006" (0.15mm)

S24 (WIDE) 0502

TYPICAL APPLICATIONS

**Clock-Tunable, 30kHz to 90kHz 8th Order Notch Filter
Providing Notch Depth in Excess of 60dB**

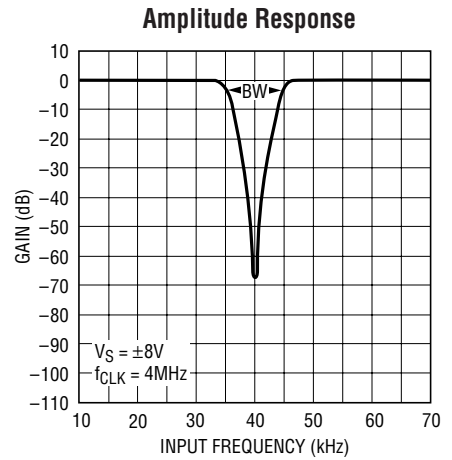
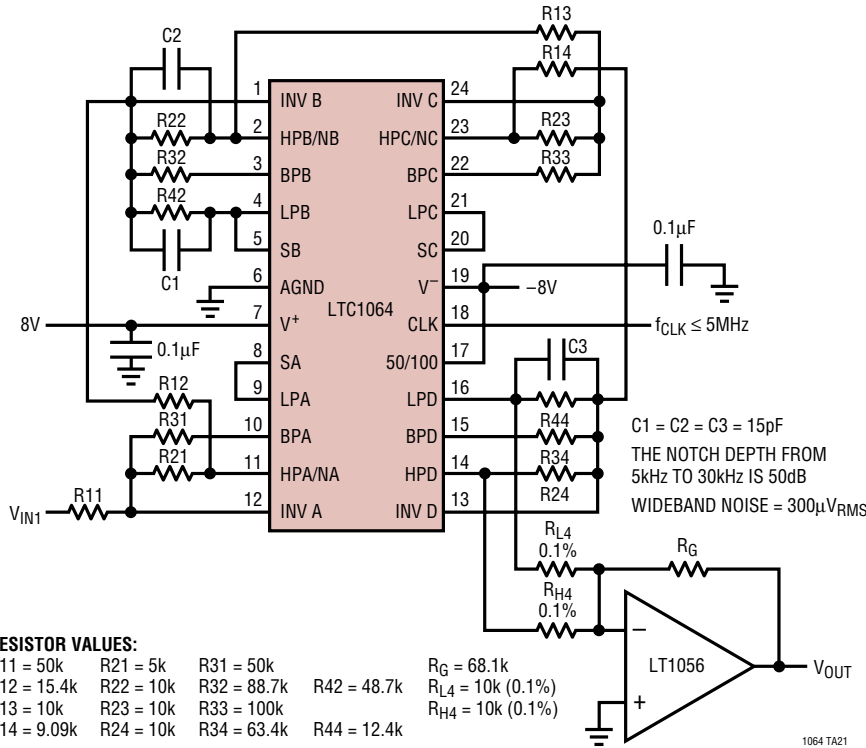

1064 TA22

1064 TA21

RELATED PARTS

PART NUMBER	DESCRIPTION	COMMENT
LTC1061	Triple Universal Filter Building Block	Three Filter Building Blocks in a 20-Pin Package
LTC1068 Series	Quad Universal Building Blocks	$f_{CLK}:f_0 = 25:1, 50:1, 100:1$ and $200:1$
LTC1164	Low Power, Quad Universal Filter Building Block	Low Noise, Low Power Pin-for-Pin LTC1064 Compatible
LTC1264	High Speed, Quad Universal Building Block	Up to 250kHz Center Frequency

Looking for pricing, stock, or lifecycle information?

Click below to explore more details on WIN SOURCE:

 [View LTC1064CSW#PBF on WIN SOURCE](#)

 [Linear Technology](#) Information

Optimize Your Supply Chain with WIN SOURCE Solutions

-  Global Sourcing Solution
-  Obsolete Management
-  Cost Control Management
-  Shortage Management
-  Alternative Solution
-  Excess Inventory Management