



**THE DATASHEET OF
LT3492IFE#PBF**



Triple Output LED Driver with 3000:1 PWM Dimming

FEATURES

- True Color PWM™ Dimming Delivers Up to 3000:1 Dimming Ratio
- Built-In Gate Driver for PMOS LED Disconnect
- Three Independent Driver Channels with 600mA, 60V Internal Switches
- Operates in Buck, Boost, Buck-Boost Modes
- CTRL Pin Accurately Sets LED Current Sense Threshold Over a Range of 10mV to 100mV
- Adjustable Frequency: 330kHz to 2.1MHz
- Open LED Protection
- Wide Input Voltage Range:
 - Operation from 3V to 30V
 - Transient Protection to 40V
- Surface Mount Components
- 28-Lead (4mm × 5mm) QFN and TSSOP Packages

APPLICATIONS

- RGB Lighting
- Billboards and Large Displays
- Automotive and Avionic Lighting
- Constant-Current Sources

DESCRIPTION

The LT®3492 is a triple output DC/DC converter designed to operate as a constant-current source and is ideal for driving LEDs. The LT3492 works in buck, boost or buck-boost mode. The LT3492 uses a fixed frequency, current mode architecture resulting in stable operation over a wide range of supply and output voltages. A frequency adjust pin allows the user to program switching frequency between 330kHz and 2.1MHz to optimize efficiency and external component size.

The external PWM input provides 3000:1 LED dimming on each channel. Each of the three channels has a built-in gate driver to drive an external LED-disconnect P-channel MOSFET, allowing high dimming range. The output current range of each channel of the LT3492 is programmed with an external sense resistor.

The CTRL pin is used to adjust the LED current either for analog dimming or overtemperature protection.

LT, LT, LTC, LTM, Linear Technology and the Linear logo are registered trademarks of Linear Technology Corporation. True Color PWM is a trademark of Linear Technology Corporation. All other trademarks are the property of their respective owners. Protected by U.S. Patents, including 7199560, 7321203, and others pending.

TYPICAL APPLICATION

High Dimming Ratio Triple Output Buck-Mode LED Power Supply

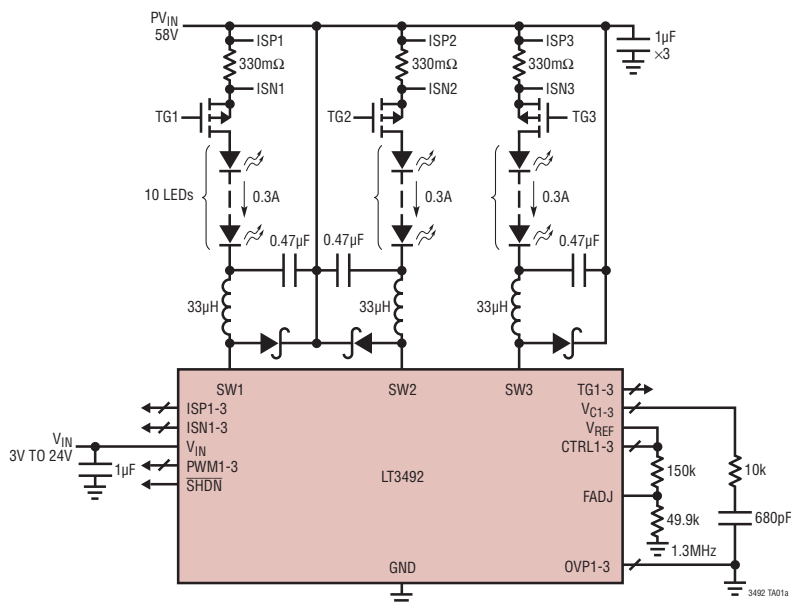

3000:1 PWM Dimming at 100Hz

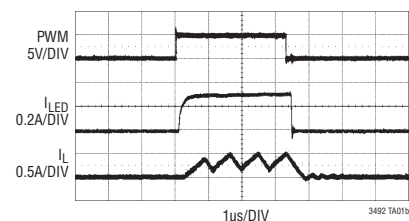

ABSOLUTE MAXIMUM RATINGS

(Note 1)

V_{IN} (Note 4).....	40V
SW1-SW3, ISN1-ISN3, ISP1-ISP3.....	60V
TG1-TG3	ISP – 10V to ISP
PWM1-PWM3	20V
V_{REF} , CTRL1-CTRL3, FADJ, V_{C1} - V_{C3} , OVP1-OVP3.....	2.5V
SHDN (Note 4)	V_{IN}

Operating Junction Temperature Range	
(Note 2).....	-40°C to 125°C
Max Junction Temperature.....	125°C
Storage Temperature Range	
TSSOP	-65°C to 150°C
UFD.....	-65°C to 125°C

PIN CONFIGURATION

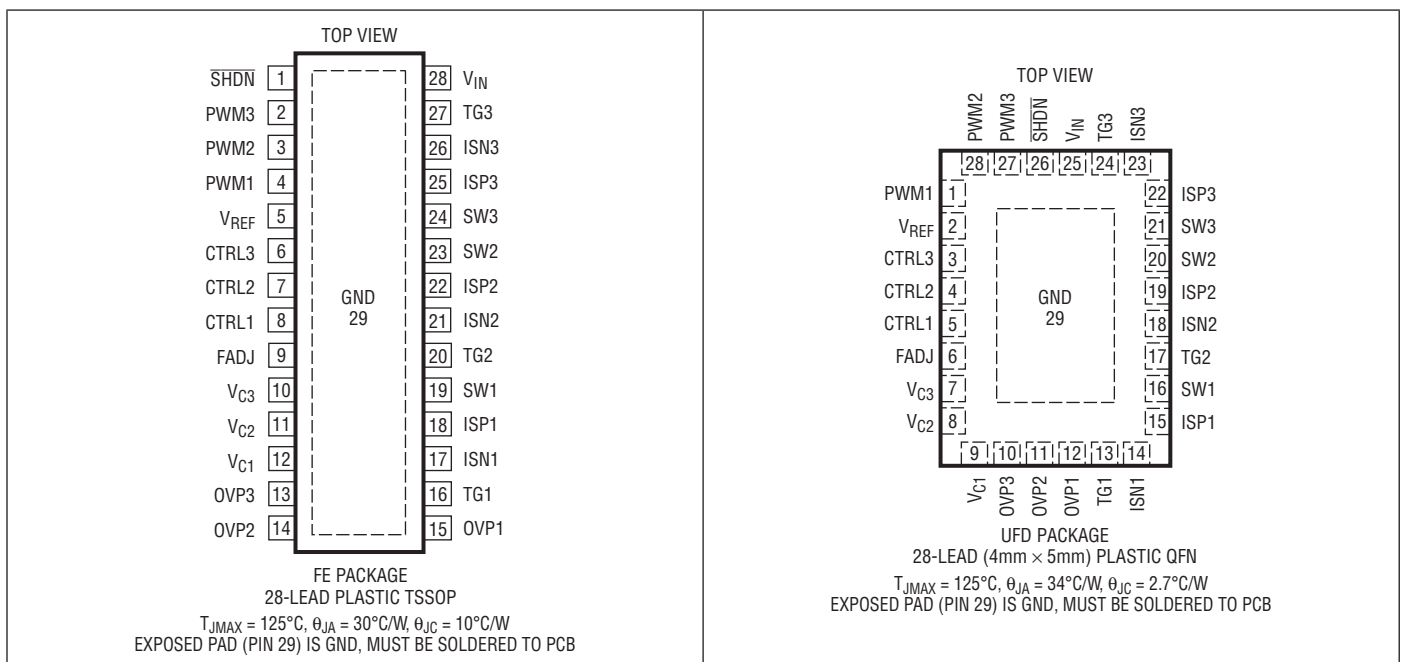

ORDER INFORMATION

LEAD FREE FINISH	TAPE AND REEL	PART MARKING*	PACKAGE DESCRIPTION	TEMPERATURE RANGE
LT3492EFE#PBF	LT3492EFE#TRPBF	LT3492FE	28-Lead Plastic TSSOP	-40°C to 125°C
LT3492IFE#PBF	LT3492IFE#TRPBF	LT3492FE	28-Lead Plastic TSSOP	-40°C to 125°C
LT3492EUFD#PBF	LT3492EUFD#TRPBF	3492	28-Lead (4mm × 5mm) Plastic QFN	-40°C to 125°C
LT3492IUFD#PBF	LT3492IUFD#TRPBF	3492	28-Lead (4mm × 5mm) Plastic QFN	-40°C to 125°C

Consult LTC Marketing for parts specified with wider operating temperature ranges. *The temperature grade is identified by a label on the shipping container. Consult LTC Marketing for information on non-standard lead based finish parts.

*For more information on lead free part marking, go to: <http://www.linear.com/leadfree/>
For more information on tape and reel specifications, go to: <http://www.linear.com/tapeandree/>

ELECTRICAL CHARACTERISTICS The ● denotes the specifications which apply over the full operating temperature range, otherwise specifications are at $T_A = 25^\circ\text{C}$. $V_{IN} = 5\text{V}$, $\overline{\text{SHDN}} = 5\text{V}$, $\text{PWM1-3} = 5\text{V}$, $\text{FADJ} = 0.5\text{V}$, $\text{CTRL1-3} = 1.5\text{V}$, $\text{OVP1-3} = 0\text{V}$, unless otherwise noted.

PARAMETER	CONDITIONS	MIN	TYP	MAX	UNITS
V_{IN} Operation Voltage	(Note 4)	3		30	V
V_{IN} Undervoltage Lockout			2.1	2.4	V
Full-Scale LED Current Sense Voltage	$\text{ISP1-3} = 48\text{V}$	98 96	100	103 104	mV mV
One-Tenth Scale LED Current Sense Voltage	$\text{CTRL1-3} = 100\text{mV}$, $\text{ISP1-3} = 48\text{V}$	7	10	13	mV
ISPn/ISNn Operating Voltage		2.5		60	V
V_{REF} Output Voltage	$I_{REF} = 200\mu\text{A}$, Current Out of Pin	1.96	2	2.04	V
V_{REF} Line Regulation	$3\text{V} \leq V_{IN} \leq 40\text{V}$, $I_{REF} = 10\mu\text{A}$			0.03	%/V
Quiescent Current in Shutdown	$\overline{\text{SHDN}} = 0\text{V}$		0.1	10	μA
Quiescent Current Idle	$\text{PWM1-PWM3} = 0\text{V}$		6	8	mA
Quiescent Current Active (Not Switching)	$V_{C1-V_{C3}} = 0\text{V}$		11	15	mA
Switching Frequency	$\text{FADJ} = 1.5\text{V}$	1800	2100	2400	kHz
	$\text{FADJ} = 0.5\text{V}$	1000	1300	1600	kHz
	$\text{FADJ} = 0.1\text{V}$	280	340	400	kHz
Maximum Duty Cycle	$\text{FADJ} = 1.5\text{V}$ (2.1MHz)	73	78		%
	$\text{FADJ} = 0.5\text{V}$ (1.3MHz)	80	87		%
	$\text{FADJ} = 0.1\text{V}$ (330kHz)		97		%
CTRL1-3 Input Bias Current	Current Out of Pin, $\text{CTRL1-3} = 0.1\text{V}$		20	100	nA
FADJ Input Bias Current	Current Out of Pin, $\text{FADJ} = 0.1\text{V}$		20	100	nA
OVP1-3 Input Bias Current	Current Out of Pin, $\text{OVP1-3} = 0.1\text{V}$		10	100	nA
OVP1-3 Threshold		0.95	1	1.05	V
V_{C1-3} Idle Input Bias Current	$\text{PWM1-3} = 0\text{V}$	-20	0	20	nA
V_{C1-3} Output Impedance	$\text{ISP1-3} = 48\text{V}$		10		$\text{M}\Omega$
$\text{EAMP } g_m$ ($\Delta I_{VC}/\Delta V_{CAP-LED}$)	$\text{ISP1-3} = 48\text{V}$		200		μS
SW1-3 Current Limit	(Note 3)	600	1000	1300	mA
$\text{SW1-3 } V_{CESAT}$	$I_{SW} = 500\text{mA}$ (Note 3)		340		mV
SW1-3 Leakage Current	$\overline{\text{SHDN}} = 0\text{V}$, $\text{SW} = 5\text{V}$			2	μA

ELECTRICAL CHARACTERISTICS

The ● denotes the specifications which apply over the full operating temperature range, otherwise specifications are at $T_A = 25^\circ\text{C}$. $V_{IN} = 5\text{V}$, $\overline{\text{SHDN}} = 5\text{V}$, $\text{PWM1-3} = 5\text{V}$, $\text{FADJ} = 0.5\text{V}$, $\text{CTRL1-3} = 1.5\text{V}$, $\text{OVP1-3} = 0\text{V}$, unless otherwise noted.

PARAMETER	CONDITIONS	MIN	TYP	MAX	UNITS
ISP1-3 Input Bias Current			180	250	μA
ISP1-3, ISN1-3 Idle Input Bias Current	$\text{PWM1-3} = 0\text{V}$			1	μA
ISP1-3, ISN1-3 Input Bias Current in Shutdown	$\overline{\text{SHDN}} = 0\text{V}$			1	μA
$\overline{\text{SHDN}}$ Input Low Voltage				0.4	V
$\overline{\text{SHDN}}$ Input High Voltage		1.5			V
$\overline{\text{SHDN}}$ Pin Current	$\overline{\text{SHDN}} = 5\text{V}$, Current Into Pin		65	120	μA
PWM1-3 Input Low Voltage				0.4	V
PWM1-3 Input High Voltage		1.2			V
PWM1-3 Pin Current	Current Into Pin		160	210	μA
Gate Off Voltage (ISP1-3–TG1-3)	ISP1-3 = 60V, PWM1-3 = 0V		0.1	0.3	V
Gate On Voltage (ISP1-3–TG1-3)	ISP1-3 = 60V	5.5	6.5	7.5	V
Gate Turn-On Delay	$C_{\text{LOAD}} = 300\text{pF}$, ISP1-3 = 60V (Note 5)		110		ns
Gate Turn-Off Delay	$C_{\text{LOAD}} = 300\text{pF}$, ISP1-3 = 60V (Note 5)		110		ns

Note 1: Stresses beyond those listed under Absolute Maximum Ratings may cause permanent damage to the device. Exposure to any Absolute Maximum Rating condition for extended periods may affect device reliability and lifetime.

Note 2: The LT3492E is guaranteed to meet performance specifications from 0°C to 125°C junction temperature. Specifications over the -40°C to 125°C operating junction temperature range are assured by design, characterization and correlation with statistical process controls. The LT3492I is guaranteed over the full -40°C to 125°C operating junction temperature range.

Note 3: Current flows into pin. Current limit and switch V_{CESAT} is guaranteed by design and/or correlation to static test.

Note 4: Absolute maximum voltage at the V_{IN} and $\overline{\text{SHDN}}$ pins is 40V for nonrepetitive 1 second transients, and 30V for continuous operation.

Note 5: Gate turn-on/turn-off delay is measured from 50% level of PWM voltage to 90% level of gate on/off voltage.

TYPICAL PERFORMANCE CHARACTERISTICS ($T_A = 25^\circ\text{C}$ unless otherwise noted)

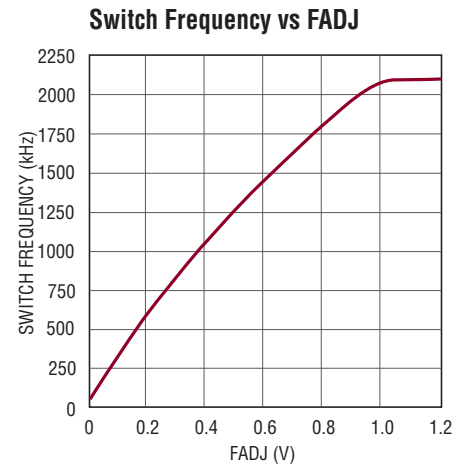
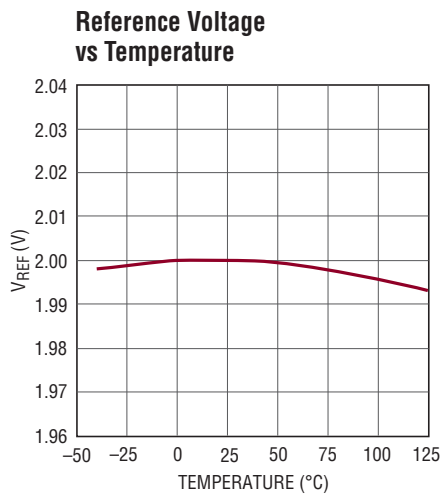
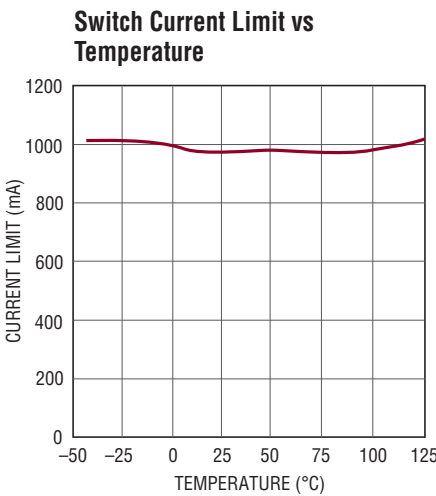
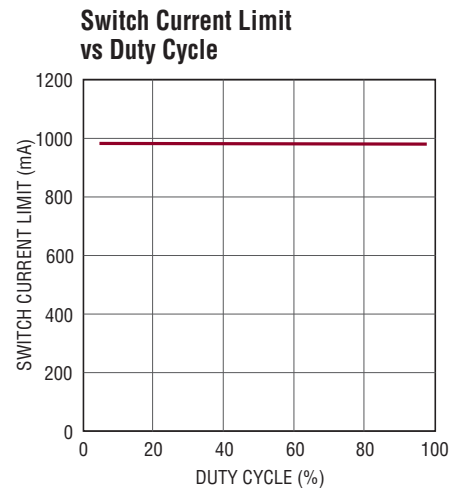
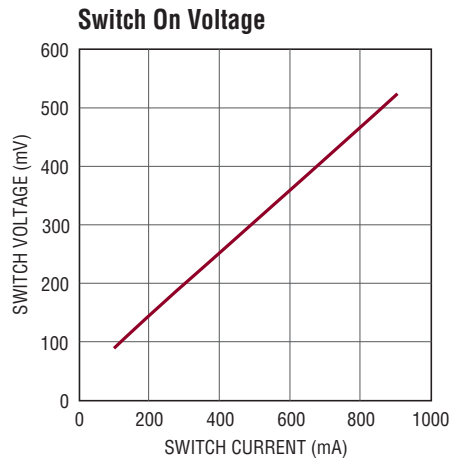
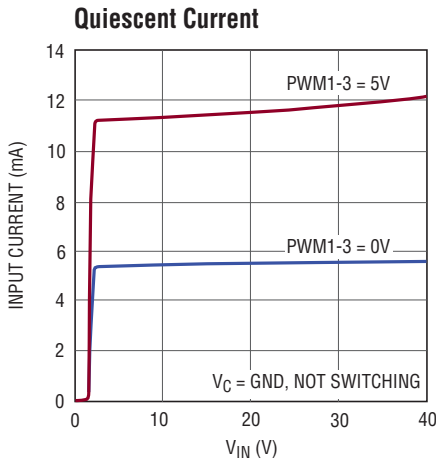

TYPICAL PERFORMANCE CHARACTERISTICS ($T_A = 25^\circ\text{C}$ unless otherwise noted)

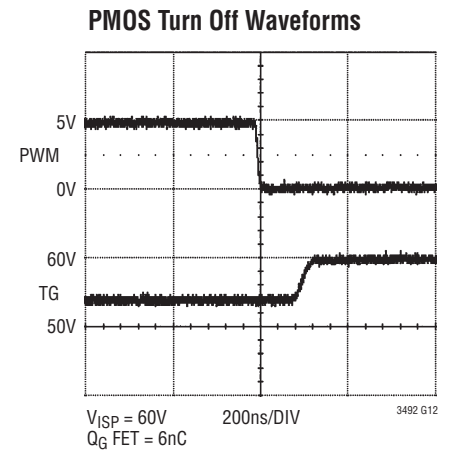
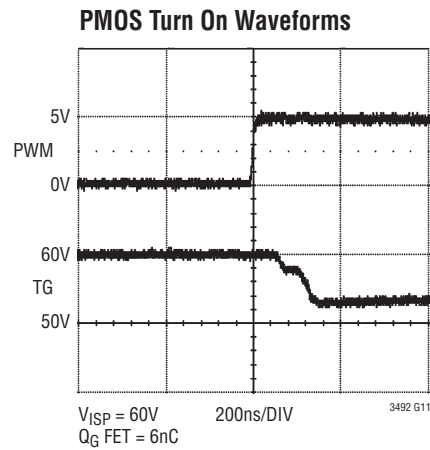
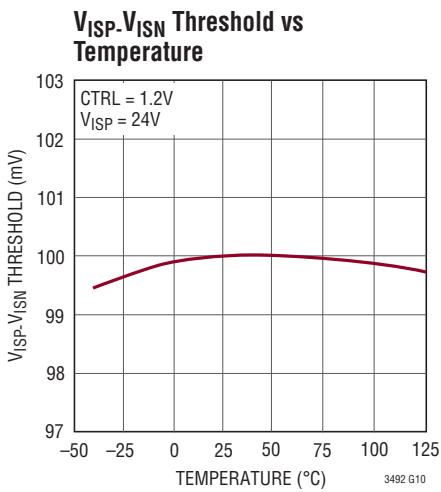
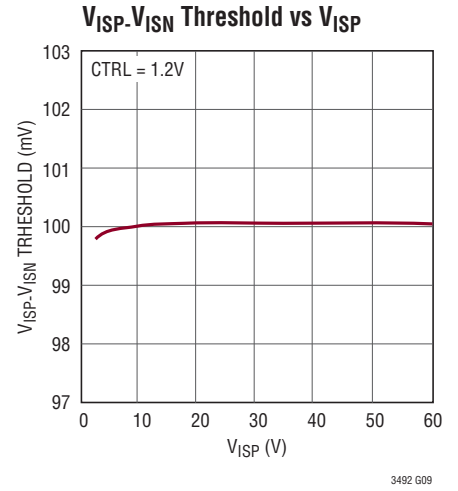
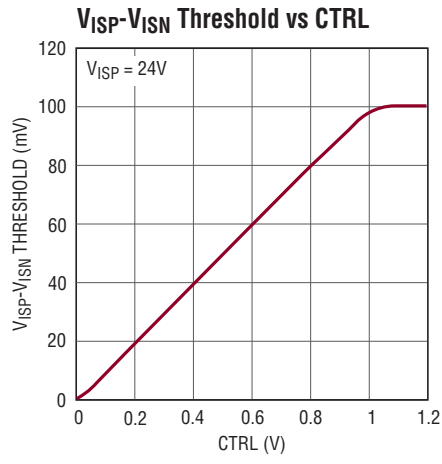
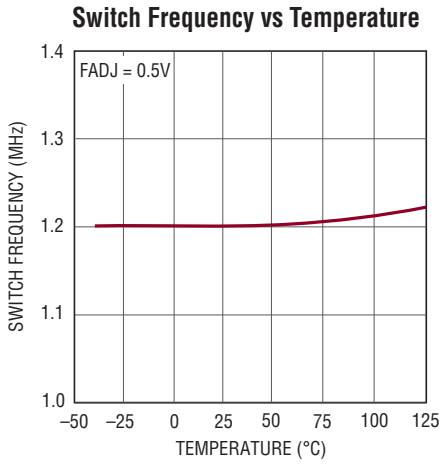

PIN FUNCTIONS

CTRL1, CTRL2, CTRL3: LED Current Adjustment Pins. Sets voltage across external sense resistor between ISP and ISN pins of the respective converter. Setting CTRL voltage to be less than 1V will control the current sense voltage to be one-tenth of CTRL voltage. If CTRL voltage is higher than 1V, the default current sense voltage is 100mV. The CTRL pin must not be left floating.

FADJ: Switching Frequency Adjustment Pin. Setting FADJ voltage to be less than 1V will adjust switching frequency up to 2.1MHz. If FADJ voltage is higher than 1V, the default switching frequency is 2.1MHz. The FADJ pin must not be left floating.

GND: Signal Ground and Power Ground. Solder exposed pad directly to ground plane.

ISN1, ISN2, ISN3: Noninverting Input of Current Sense Error Amplifier. Connect directly to LED current sense resistor terminal for current sensing of the respective converter.

ISP1, ISP2, ISP3: Inverting Input of Current Sense Error Amplifier. Connect directly to other terminal of LED current sense resistor terminal of the respective converter.

OVP1, OVP2, OVP3: Open LED Protection Pins. A voltage higher than 1V on OVP turns off the internal main switch of the respective converter. Tie to ground if not used.

PWM1, PWM2, PWM3: Pulse Width Modulated Input. Signal low turns off the respective converter, reduces

quiescent supply current and causes the V_C pin for that converter to become high impedance. PWM pin must not be left floating; tie to V_{REF} if not used.

\overline{SHDN} : Shutdown Pin. Used to shut down the switching regulator and the internal bias circuits for all three converters. Tie to 1.5V or greater to enable the device. Tie below 0.4V to turn off the device.

SW1, SW2, SW3: Switch Pins. Collector of the internal NPN power switch of the respective converter. Connect to external inductor and anode of external Schottky rectifier of the respective converter. Minimize the metal trace area connected to this pin to minimize electromagnetic interference.

TG1, TG2, TG3: The Gate Driver Output Pin for Disconnect P-Channel MOSFET. One for each converter. When the PWM pin is low, the TG pin pulls up to ISP to turn off the external MOSFET. When the PWM pin is high, the external MOSFET turns on. ISP_n-TG_n is limited to 6.5V to protect the MOSFET. Leave open if the external MOSFET is not used.

V_{C1}, V_{C2}, V_{C3} : Error Amplifier Compensation Pins. Connect a series RC from these pins to GND.

V_{IN} : Input Supply Pin. Must be locally bypassed. Powers the internal control circuitry.

V_{REF} : Reference Output Pin. Can supply up to 200 μ A. The nominal Output Voltage is 2V.

BLOCK DIAGRAM

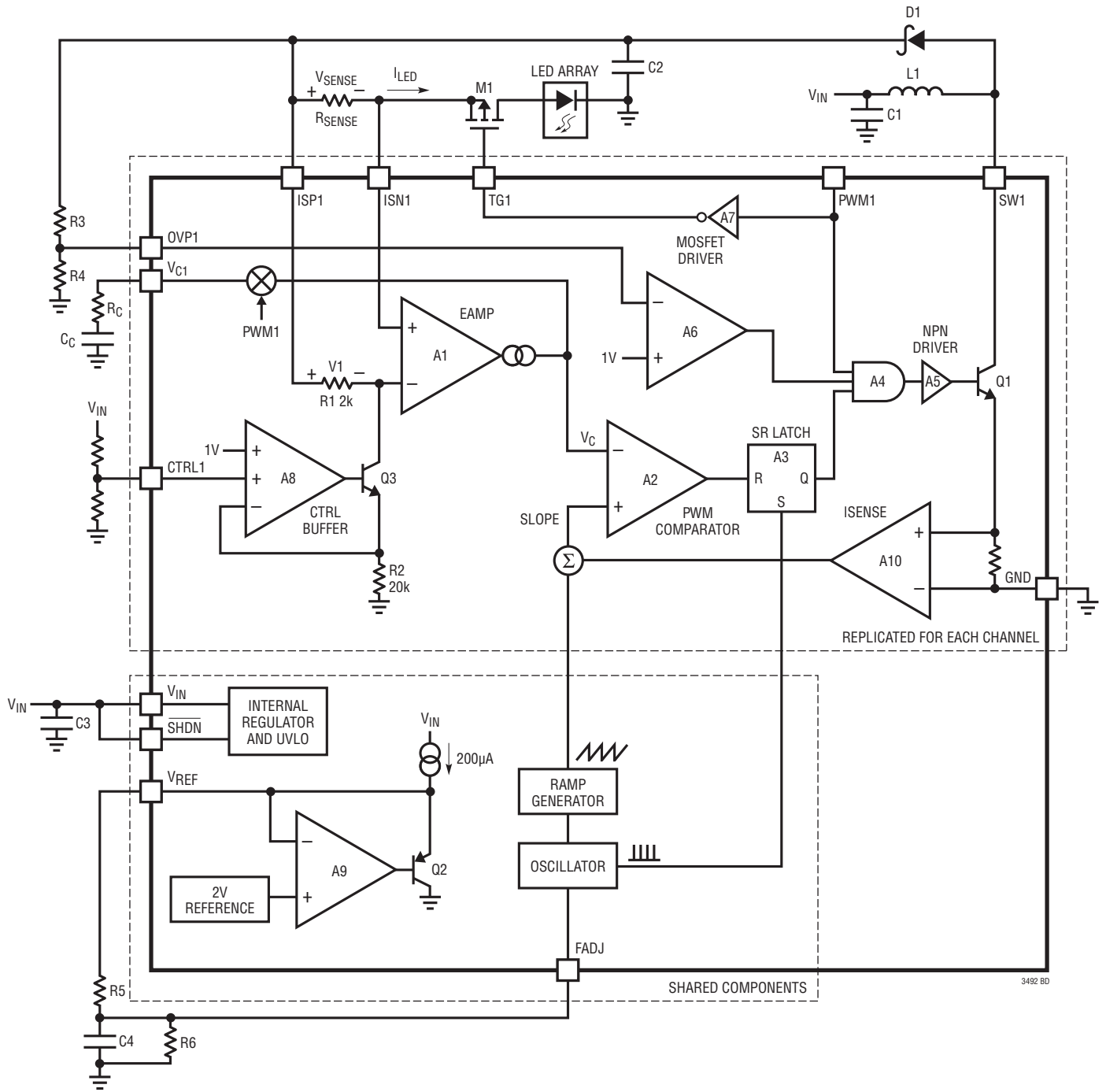

Figure 1. LT3492 Block Diagram Working in Boost Configuration

APPLICATIONS INFORMATION

Operation

The LT3492 uses a fixed frequency, current mode control scheme to provide excellent line and load regulation. Operation can be best understood by referring to the Block Diagram in Figure 1. The oscillator, ramp generator, reference, internal regulator and UVLO are shared among the three converters. The control circuitry, power switch etc., are replicated for each of the three converters. Figure 1 shows the shared circuits and only converter 1 circuits.

If the $\overline{\text{SHDN}}$ pin is logic low, the LT3492 is shut down and draws minimal current from V_{IN} . If the $\overline{\text{SHDN}}$ pin is logic high, the internal bias circuits turn on. The switching regulators start to operate when their respective PWM signal goes high.

The main control loop can be understood by following the operation of converter 1. The start of each oscillator cycle sets the SR latch, A3, and turns on power switch Q1. The signal at the noninverting input (SLOPE node) of the PWM comparator A2 is proportional to the sum of the switch current and oscillator ramp. When SLOPE exceeds V_C (the output of the error amplifier A1), A2 resets the latch and turns off the power switch Q1 through A4 and A5. In this manner, A10 and A2 set the correct peak current level to keep the output in regulation. Amplifier A8 has two noninverting inputs, one from the 1V internal voltage reference and the other one from the CTRL1 pin. Whichever input is lower takes precedence. A8, Q3 and R2 force V1, the voltage across R1, to be one tenth of either 1V or the voltage of CTRL1 pin, whichever is lower. V_{SENSE} is the voltage across the sensing resistor, R_{SENSE} , which is connected in series with the LEDs. V_{SENSE} is compared to V1 by A1. If V_{SENSE} is higher than V1, the output of A1 will decrease, thus reducing the amount of current delivered to LEDs. In this manner the current sensing voltage V_{SENSE} is regulated to V1.

Converters 2 and 3 are identical to converter 1.

PWM Dimming Control

The LED array can be dimmed with pulse width modulation using the PWM1 pin and an external P-channel MOSFET, M1. If the PWM1 pin is pulled high, M1 is turned on by internal driver A7 and converter 1 operates nominally.

A7 limits ISP1-TG1 to 6.5V to protect the gate of M1. If the PWM1 pin is pulled low, Q1 is turned off. Converter 1 stops operating, M1 is turned off, disconnects the LED array and stops current draw from output capacitor C2. The V_{C1} pin is also disconnected from the internal circuitry and draws minimal current from the compensation capacitor C_C . The V_{C1} pin and the output capacitor store the state of the LED current until PWM1 is pulled up again. This leads to a highly linear relationship between pulse width and output light, and allows for a large and accurate dimming range. A P-channel MOSFET with smaller total gate charge (Q_G) improves the dimming performance, since it can be turned on and off faster. Use a MOSFET with a Q_G lower than 10nC, and a minimum V_{TH} of -1V to -2V . Don't use a Low V_{TH} PMOS. To optimize the PWM control of all the three channels, the rising edge of all the three PWM signals should be synchronized.

In the applications where high dimming ratio is not required, M1 can be omitted to reduce cost. In these conditions, TG1 should be left open. The PWM dimming range can be further increased by using CTRL1 pin to linearly adjust the current sense threshold during the PWM1 high state.

Loop Compensation

Loop compensation determines the stability and transient performance. The LT3492 uses current mode control to regulate the output, which simplifies loop compensation. To compensate the feedback loop of the LT3492, a series resistor-capacitor network should be connected from the V_C pin to GND. For most applications, the compensation capacitor should be in the range of 100pF to 2.2nF. The compensation resistor is usually in the range of 5k to 50k.

To obtain the best performance, tradeoffs should be made in the compensation network design. A higher value of compensation capacitor improves the stability and dimming range (a larger capacitance helps hold the V_C voltage when the PWM signal is low). However, a large compensation capacitor also increases the start-up time and the time to recover from a fault condition. Similarly, a larger compensation resistor improves the transient response but may reduce the phase margin. A practical approach is to start with one of the circuits in this data sheet that

APPLICATIONS INFORMATION

is similar to your application and tune the compensation network to optimize the performance. The stability, PWM dimming waveforms and the start-up time should be checked across all operating conditions.

Open-LED Protection

The LT3492 has open-LED protection for all the three converters. As shown in Figure 1, the OVP1 pin receives the output voltage (the voltage across the output capacitor) feedback signal from an external resistor divider. OVP1 voltage is compared with a 1V internal voltage reference by comparator A6. In the event the LED string is disconnected or fails open, converter 1 output voltage will increase, causing OVP1 voltage to increase. When OVP1 voltage exceeds 1V, the power switch Q1 will turn off, and cause the output voltage to decrease. Eventually, OVP1 will be regulated to 1V and the output voltage will be limited. In the event one of the converters has an open-LED protection, the other converters will continue functioning properly.

Switching Frequency and Soft-Start

The LT3492 switching frequency is controlled by FADJ pin voltage. Setting FADJ voltage to be less than 1V will reduce switching frequency.

If FADJ voltage is higher than 1V, the default switching frequency is 2.1MHz. In general, a lower switching frequency should be used where either very high or very low switch duty cycle is required or higher efficiency is desired. Selection of a higher switching frequency will allow use of low value external components and yield a smaller solution size and profile.

As a cautionary note, operation of the LT3492 at a combination of high switching frequency with high output voltage and high switch current may cause excessive internal power dissipation. Consideration should be given to selecting a switching frequency less than 1MHz if these conditions exist.

Connecting FADJ pin to a lowpass filter (R5 and C4 in Figure 1) from the REF pin provides a soft-start function. During start-up, FADJ voltage increases slowly from 0V to the setting voltage. As a result, the switching frequency increases slowly to the setting frequency. This function limits the inrush current during start-up.

Input Capacitor Selection

For proper operation, it is necessary to place a bypass capacitor to GND close to the V_{IN} pin of the LT3492. A 1 μ F or greater capacitor with low ESR should be used. A ceramic capacitor is usually the best choice.

In the buck mode configuration, the capacitor at PV_{IN} has large pulsed currents due to the current returned through the Schottky diode when the switch is off. For the best reliability, this capacitor should have low ESR and ESL and have an adequate ripple current rating. The RMS input current is:

$$I_{IN(RMS)} = I_{LED} \cdot \sqrt{(1-D) \cdot D}$$

where D is the switch duty cycle. A 1 μ F ceramic type capacitor placed close to the Schottky diode and the ground plane is usually sufficient for each channel.

Output Capacitor Selection

The selection of output filter capacitor depends on the load and converter configuration, i.e., step-up or step-down. For LED applications, the equivalent resistance of the LED is typically low, and the output filter capacitor should be large enough to attenuate the current ripple.

To achieve the same LED ripple current, the required filter capacitor value is larger in the boost and buck-boost mode applications than that in the buck mode applications. For the LED buck mode applications at 1.3MHz, a 0.22 μ F ceramic capacitor is usually sufficient for each channel. For the LED boost and buck-boost applications at 1.3MHz, a 1 μ F ceramic capacitor is usually sufficient for each channel. Lower switching frequency requires proportionately higher capacitor values. If higher LED current ripple can be tolerated, a lower output capacitance can be selected to reduce the capacitor's cost and size.

Use only ceramic capacitors with X7R or X5R dielectric, as they are good for temperature and DC bias stability of the capacitor value. All ceramic capacitors exhibit loss of capacitance value with increasing DC voltage bias, so it may be necessary to choose a higher value capacitor to get the required capacitance at the operation voltage. Always check that the voltage rating of the capacitor is sufficient. Table 1 shows some recommended capacitor vendors.

3492fa

APPLICATIONS INFORMATION

Table 1. Ceramic Capacitor Manufacturers

VENDOR	TYPE	SERIES
Taiyo Yuden	Ceramic	X5R, X7R
AVX	Ceramic	X5R, X7R
Murata	Ceramic	X5R, X7R
Kemet	Ceramic	X5R, X7R
TDK	Ceramic	X5R, X7R

Inductor Selection

Inductor value is selected based on switching frequency and desired transient response. The data sheet applications show appropriate selections for a 1.3MHz switching frequency. Proportionately higher values may be used if a lower switching frequency is selected.

Several inductors that work well with the LT3492 are listed in Table 2. However, there are many other manufacturers and devices that can be used. Consult each manufacturer for more detailed information and their entire range of parts. Ferrite core inductors should be used to obtain the best efficiency. Choose an inductor that can handle the necessary peak current without saturating, and ensure that the inductor has a low DCR (copper-wire resistance) to minimize I^2R power losses. An inductor with a magnetic shield should be used to prevent noise radiation and cross coupling among the three channels.

Diode Selection

The Schottky diode conducts current during the interval when the switch is turned off. Select a diode V_R rated for the maximum SW voltage. It is not necessary that the forward current rating of the diode equal the switch current limit. The average current, I_F , through the diode is a function of the switch duty cycle. Select a diode with forward current rating of:

$$I_F = I_L \cdot (1 - D)$$

where I_L is the inductor current.

If using the PWM feature for dimming, it is important to consider diode leakage, which increases with the temperature from the output during the PWM low interval. Therefore, choose the Schottky diode with sufficient low leakage current at hot temperature. Table 3 shows several Schottky diodes that work well with the LT3492.

Table 2. Surface Mount Inductors

PART NUMBER	VALUE (µH)	DCR (Ω MAX)	I _{RMS} (A)	SIZE W × L × H (mm3)
Sumida				
CDRH4D28	15	0.149	0.76	5.0 × 5.0 × 3.0
CDRH5D28	22	0.122	0.9	6.0 × 6.0 × 3.0
	33	0.189	0.75	
CooperET				
SD20	15	0.1655	1.25	5.0 × 5.0 × 2.0
	22	0.2053	1.12	
SD25	33	0.2149	1.11	5.0 × 5.0 × 2.5
Taiyo Yuden				
NP04SZB	15	0.180	0.95	4.0 × 4.0 × 1.8
	22	0.210	0.77	
TDK				
VLF5014A	15	0.32	0.97	4.5 × 4.7 × 1.4
	22	0.46	0.51	
Würth Electronics				
7447789133	33	0.24	1.22	7.3 × 7.3 × 3.2
Coilcraft				
M556132	22	0.19	1.45	6.1 × 6.1 × 3.2

Table 3. Schottky Diodes

PART NUMBER	V _R (V)	I _F (A)	PACKAGE
ZETEX			
ZLLS350	40	0.38	SOD523
ZLLS400	40	0.52	SOD323
DIODES			
B1100	100	1.0	SMA
ROHM			
RB160M-60	60	1.0	PMDU/SOD-123

Undervoltage Lockout

The LT3492 has an undervoltage lockout circuit that shuts down all the three converters when the input voltage drops below 2.1V. This prevents the converter from switching in an erratic mode when powered from a low supply voltage.

Programming the LED Current

An important consideration when using a switch with a fixed current limit is whether the regulator will be able to supply the load at the extremes of input and output voltage range. Several equations are provided to help determine

APPLICATIONS INFORMATION

this capability. Some margin to data sheet limits is included, along with provision for 200mA inductor ripple current.

For boost mode converters:

$$I_{OUT(MAX)} \cong 0.4A \frac{V_{IN(MIN)}}{V_{OUT(MAX)}}$$

For buck mode converters:

$$I_{LED(MAX)} \cong 0.4A$$

For SEPIC and buck-boost mode converters:

$$I_{OUT(MAX)} \cong 0.4A \frac{V_{IN(MIN)}}{(V_{OUT(MAX)} + V_{IN(MIN)})}$$

If some level of analog dimming is acceptable at minimum supply levels, then the CTRL pin can be used with a resistor divider to V_{IN} (as shown in the Block Diagram) to provide a higher output current at nominal V_{IN} levels.

The LED current of each channel is programmed by connecting an external sense resistor R_{SENSE} in series with the LED load, and setting the voltage regulation threshold across that sense resistor using CTRL input. If the CTRL voltage, V_{CTRL} , is less than 1V, the LED current is:

$$I_{LED} = \frac{V_{CTRL}}{10 \cdot R_{SENSE}}$$

If V_{CTRL} is higher than 1V, the LED current is:

$$I_{LED} = \frac{100mV}{R_{SENSE}}$$

The CTRL pins should not be left open. The CTRL pin can also be used in conjunction with a PTC thermistor to provide overtemperature protection for the LED load as shown in Figure 2.

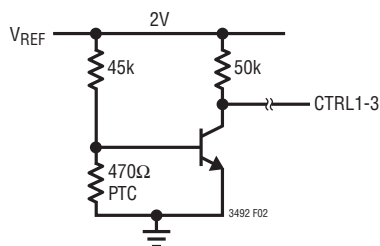

Figure 2

Thermal Considerations

The LT3492 is rated to a maximum input voltage of 30V for continuous operation, and 40V for nonrepetitive one second transients. Careful attention must be paid to the internal power dissipation of the LT3492 at higher input voltages and higher switching frequencies/output voltage to ensure that a junction temperature of 125°C is not exceeded. This is especially important when operating at high ambient temperatures. Consider driving V_{IN} from 5V or higher to ensure the fastest switching edges, and minimize one source of switching loss. The exposed pad on the bottom of the package must be soldered to a ground plane. This ground should then be connected to an internal copper ground plane with thermal vias placed directly under the package to spread out the heat dissipated by the LT3492.

Board Layout

The high speed operation of the LT3492 demands careful attention to board layout and component placement. The exposed pad of the package is the only GND terminal of the IC and is important for thermal management of the IC. Therefore, it is crucial to achieve a good electrical and thermal contact between the exposed pad and the ground plane of the board. Also, in boost configuration, the Schottky rectifier and the capacitor between GND and the cathode of the Schottky are in the high frequency switching path where current flow is discontinuous. These elements should be placed so as to minimize the path between SW and the GND of the IC. To reduce electromagnetic interference (EMI), it is important to minimize the area of the SW node. Use the GND plane under SW to minimize interplane coupling to sensitive signals. To obtain good current regulation accuracy and eliminate sources of channel to channel coupling, the ISP and ISN inputs of each channel of the LT3492 should be run as separate lines back to the terminals of the sense resistor. Any resistance in series with ISP and ISN inputs should be minimized. Avoid extensive routing of high impedance traces such as OVP and V_C . Make sure these sensitive signals are star coupled to the GND under the IC rather than a GND where switching currents are flowing. Finally, the bypass capacitor on the V_{IN} supply to the LT3492 should be placed as close as possible to the V_{IN} terminal of the device.

3492fa

TYPICAL APPLICATIONS

Minimum BOM Buck Mode LED Driver

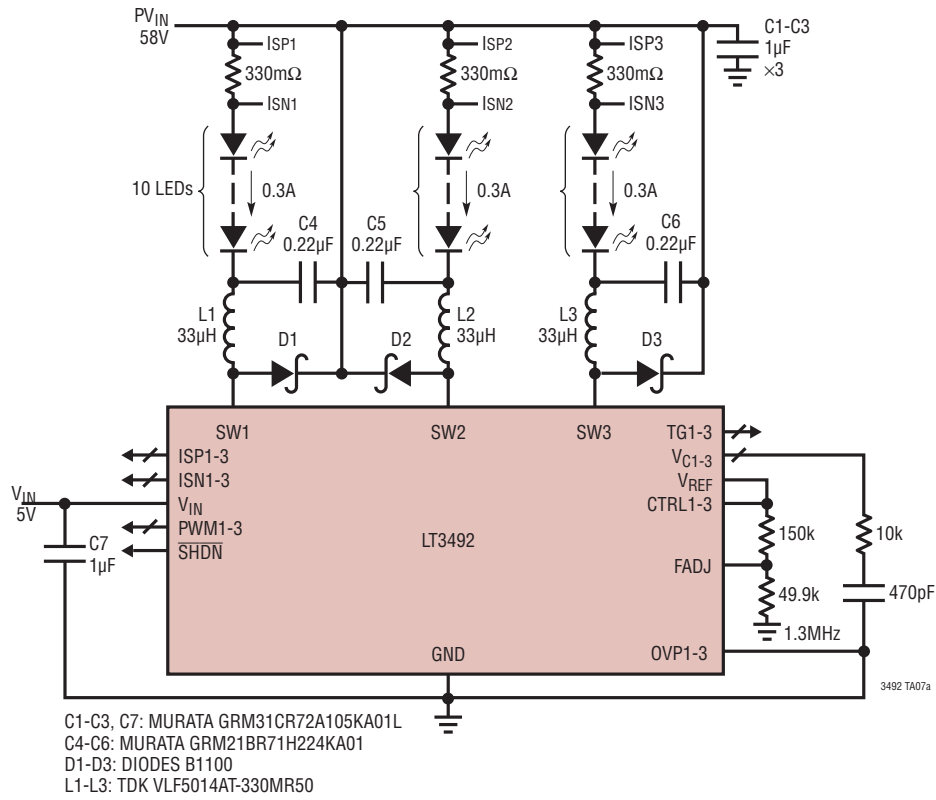

300:1 PWM Dimming at 100Hz

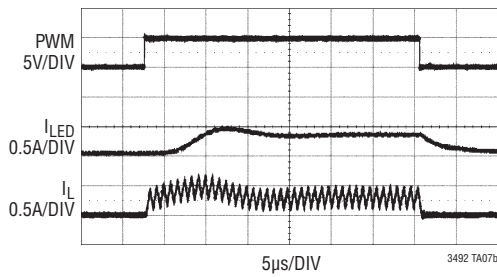

Efficiency

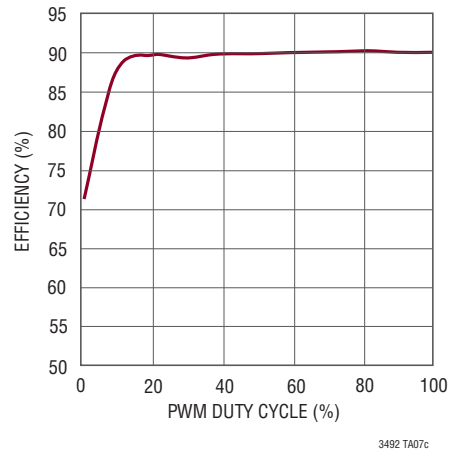

TYPICAL APPLICATIONS

Triple Boost 100mA × 12 LED Driver

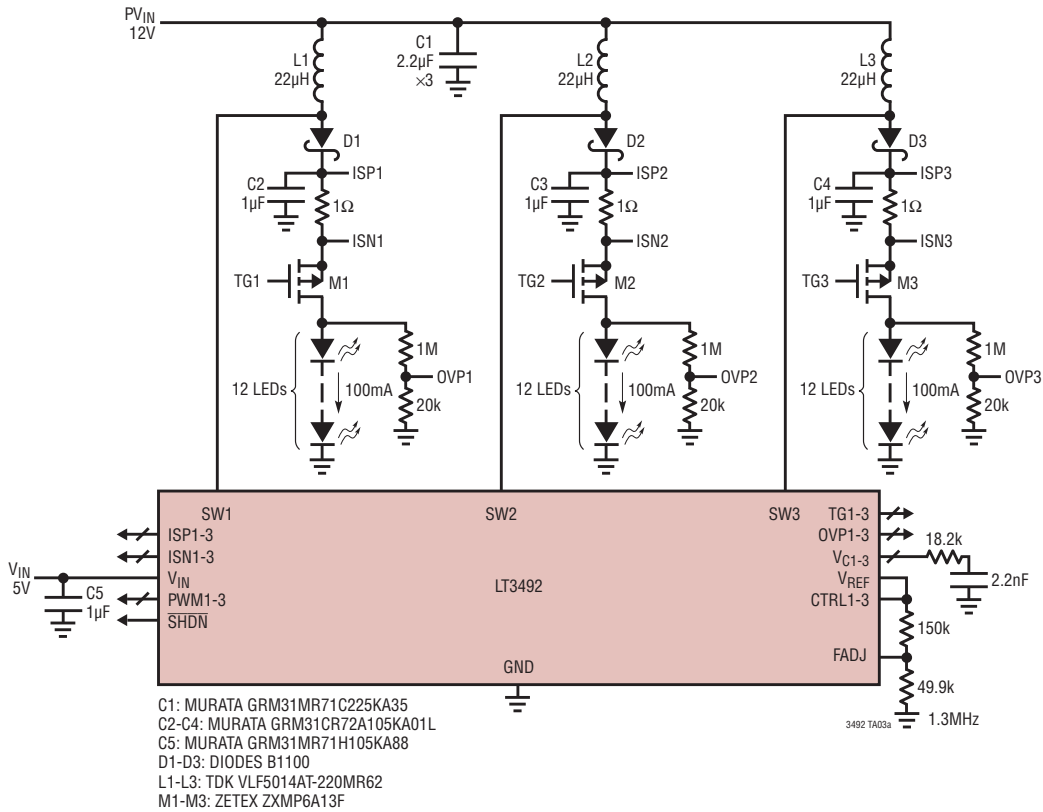

1000:1 PWM Dimming at 100Hz

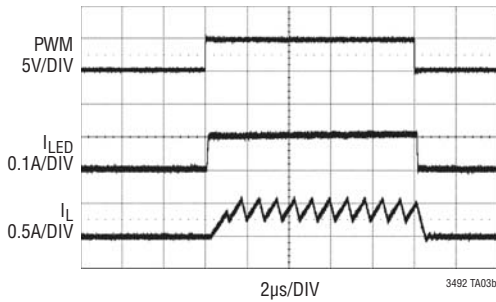

Efficiency vs PWM Duty Cycle

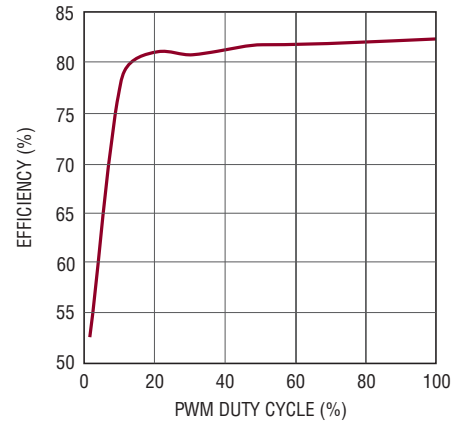

TYPICAL APPLICATIONS

Dual Boost LED Driver

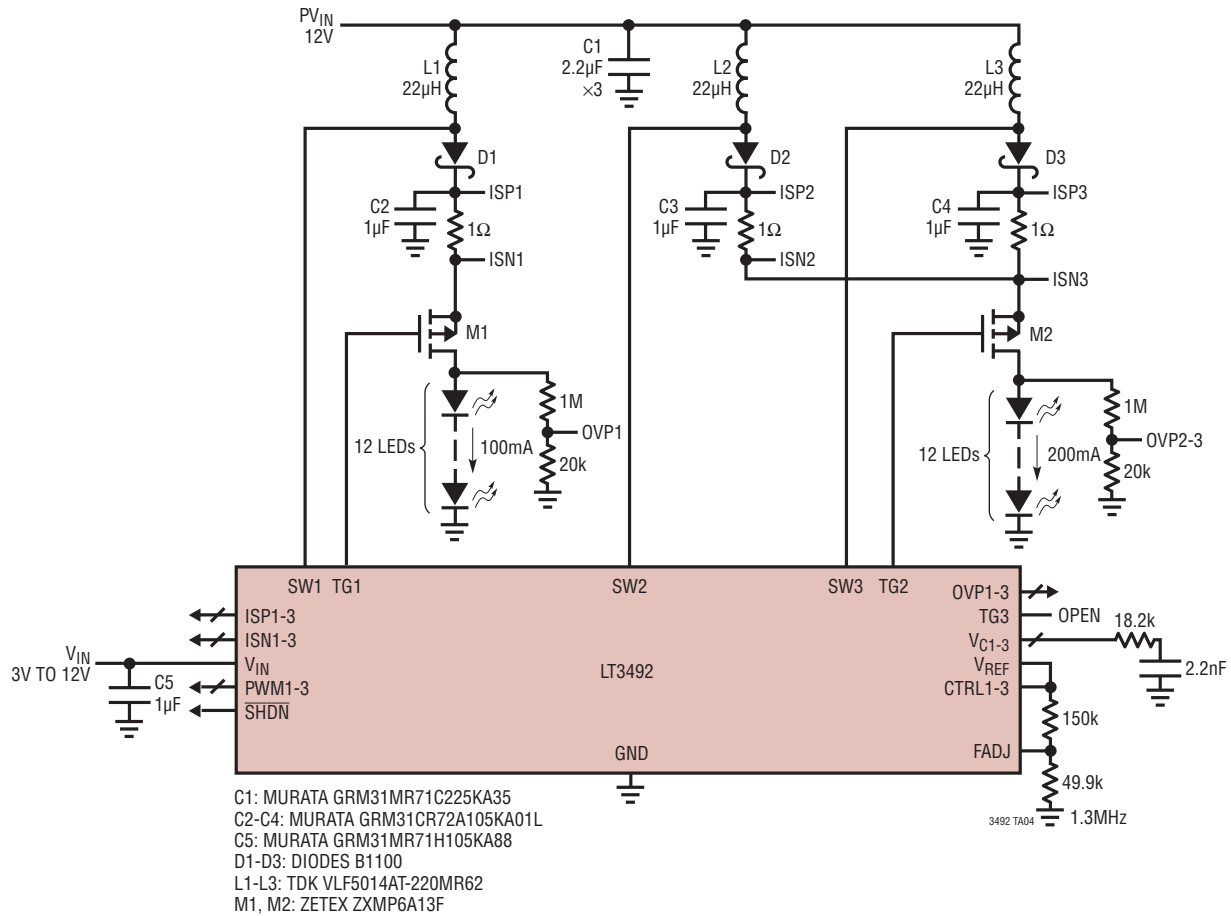

1000:1 PWM Dimming at 100Hz for 200mA LEDs

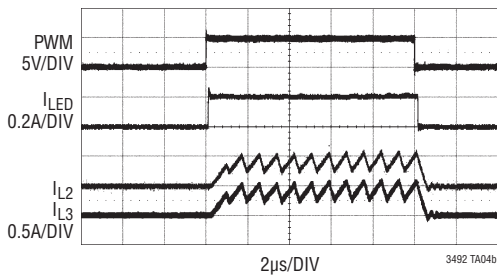

Efficiency vs PWM Duty Cycle for 200mA LEDs

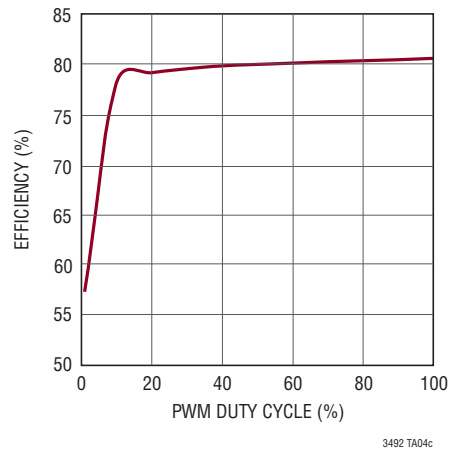

TYPICAL APPLICATIONS

Triple Boost 100mA × 9 LED Driver with V_{IN} Controlled Dimming

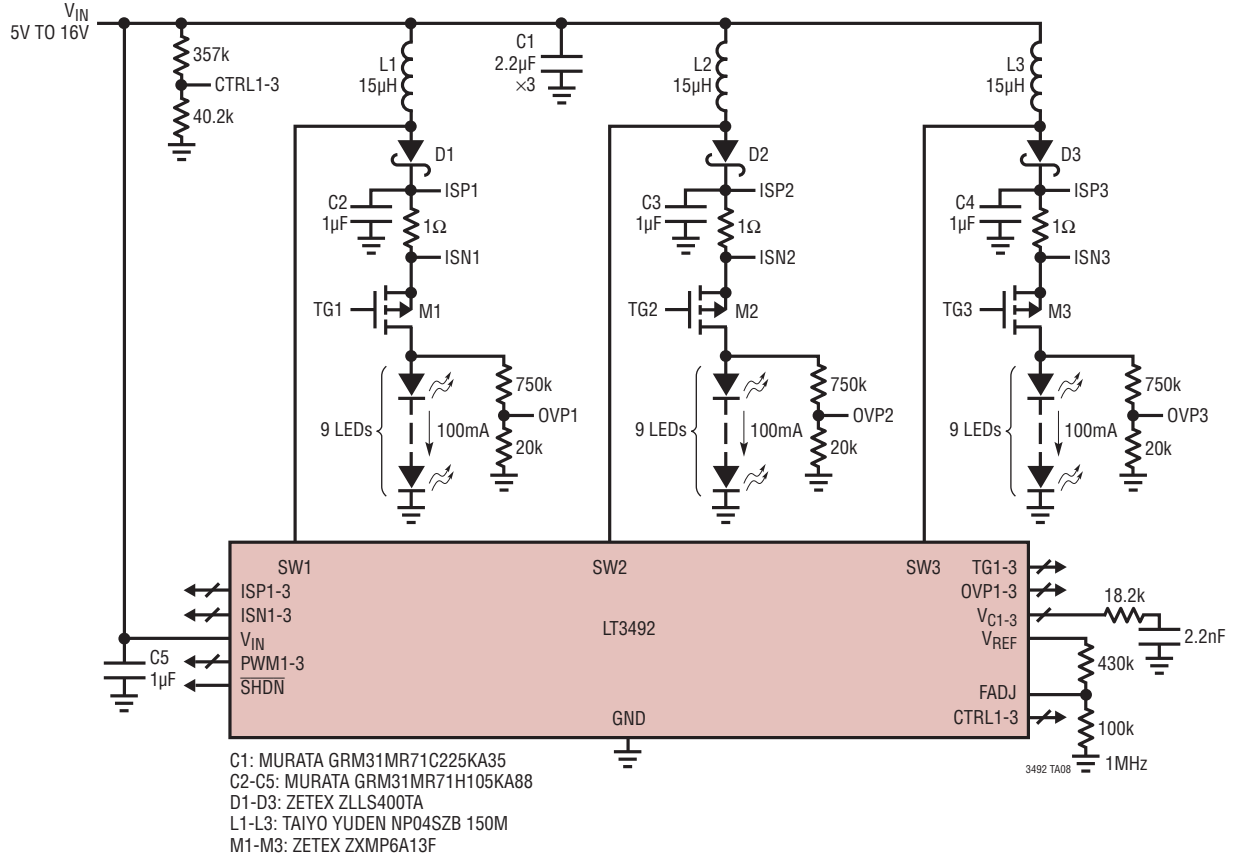

LED Current Decreasing with V_{IN}

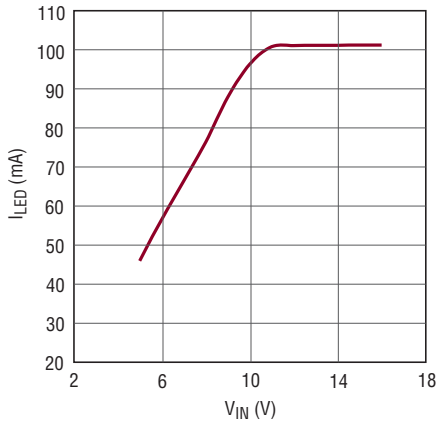

Efficiency vs V_{IN}

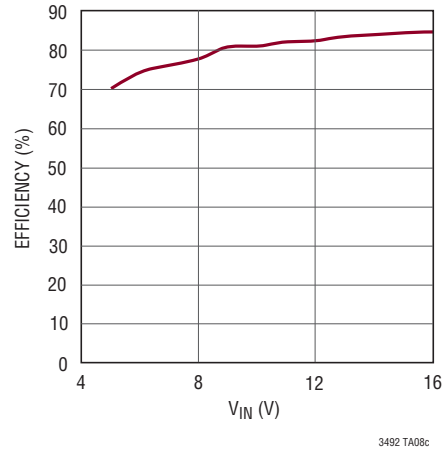

TYPICAL APPLICATIONS

Triple LED Driver Driving LED Strings in Buck, Boost and Buck-Boost Modes

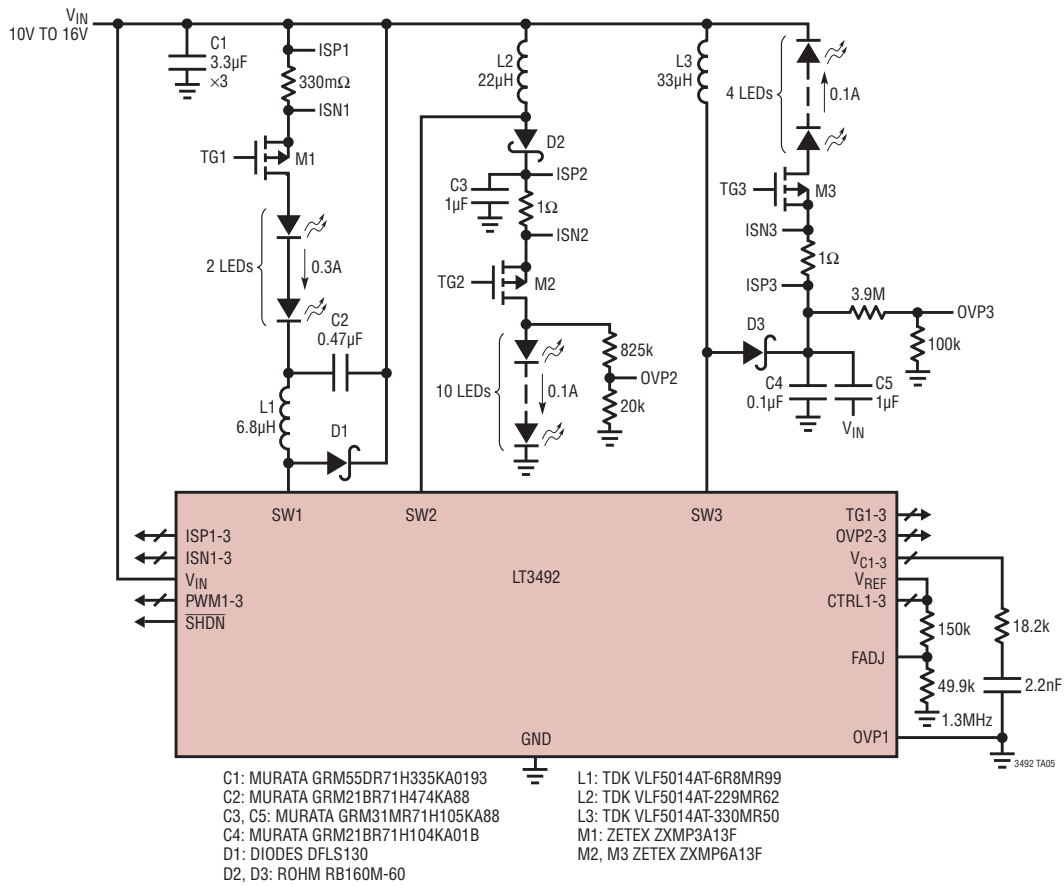

3000:1 PWM Dimming at 100Hz for CH1 (Buck Mode)

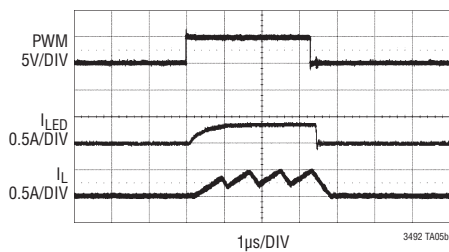

3000:1 PWM Dimming at 100Hz for CH2 (Boost Mode)

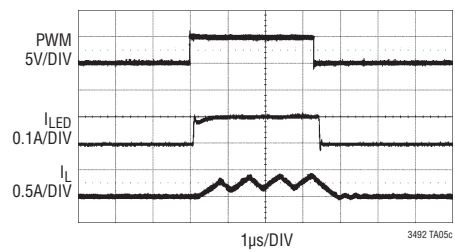

3000:1 PWM Dimming at 100Hz for CH3 (Buck-Boost Mode)

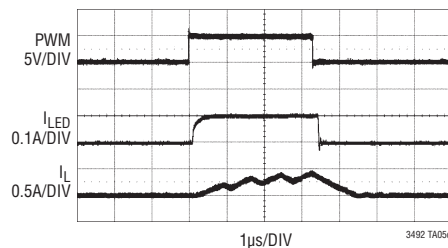

TYPICAL APPLICATIONS

Triple Buck Mode LED Driver with Open LED Protection

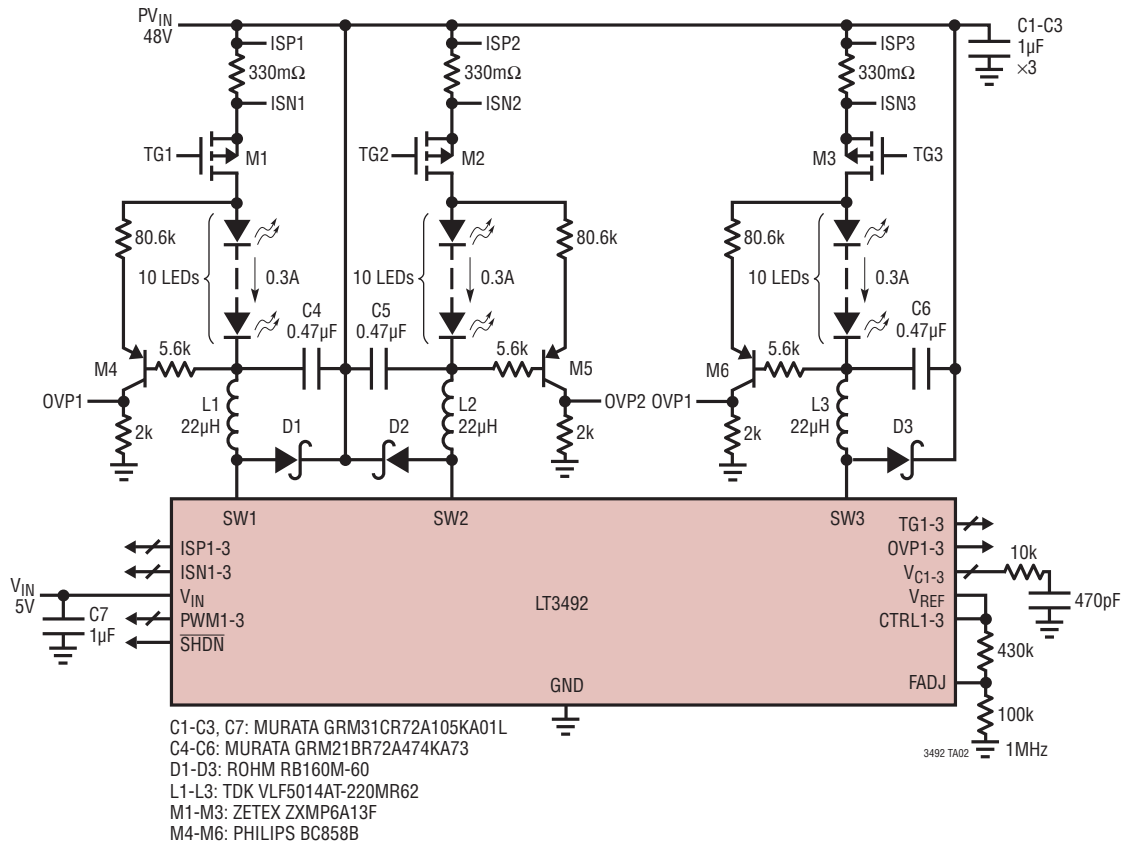

2000:1 PWM Dimming at 100Hz

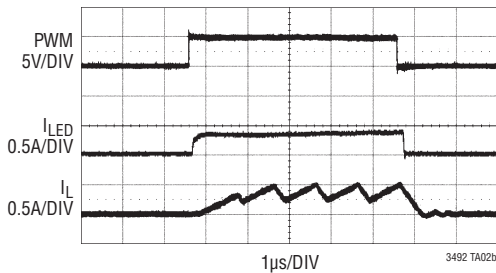

Efficiency vs PWM Duty Cycle for 200mA LEDs

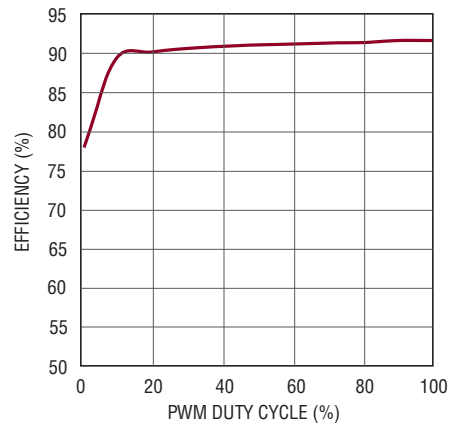

PACKAGE DESCRIPTION

**FE Package
28-Lead Plastic TSSOP (4.4mm)
(Reference LTC DWG # 05-08-1663)
Exposed Pad Variation EB**

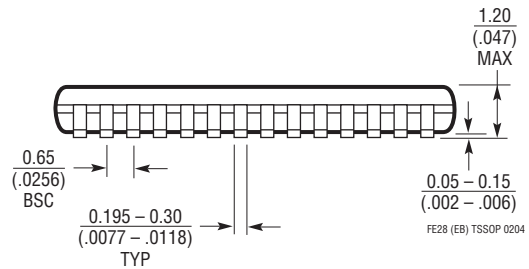
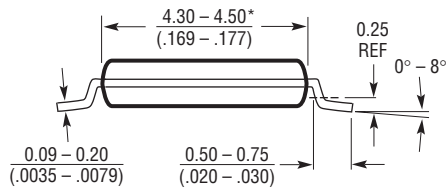
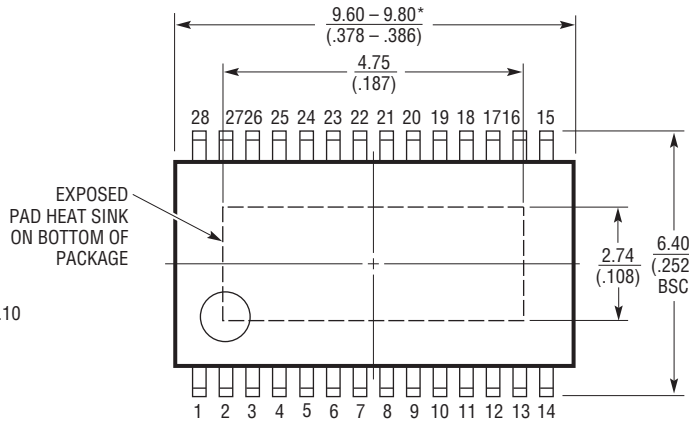
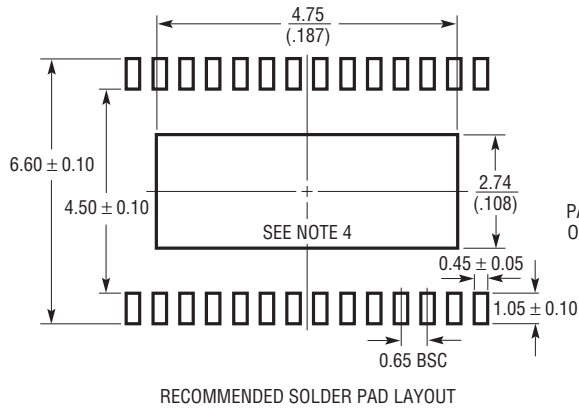

NOTE:

- 1. CONTROLLING DIMENSION: MILLIMETERS
- 2. DIMENSIONS ARE IN MILLIMETERS (INCHES)
- 3. DRAWING NOT TO SCALE

- 4. RECOMMENDED MINIMUM PCB METAL SIZE FOR EXPOSED PAD ATTACHMENT

*DIMENSIONS DO NOT INCLUDE MOLD FLASH. MOLD FLASH SHALL NOT EXCEED 0.150mm (.006") PER SIDE

PACKAGE DESCRIPTION

UFD Package
28-Lead Plastic QFN (4mm × 5mm)
 (Reference LTC DWG # 05-08-1712 Rev B)

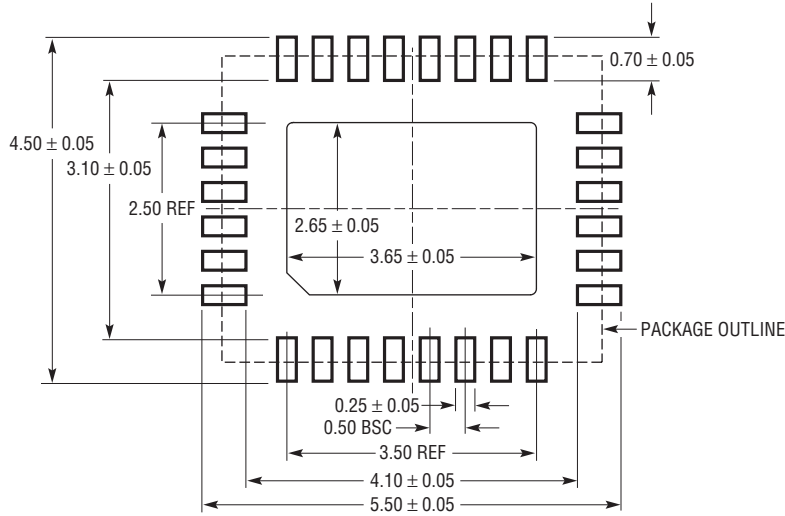

RECOMMENDED SOLDER PAD PITCH AND DIMENSIONS
 APPLY SOLDER MASK TO AREAS THAT ARE NOT SOLDERED

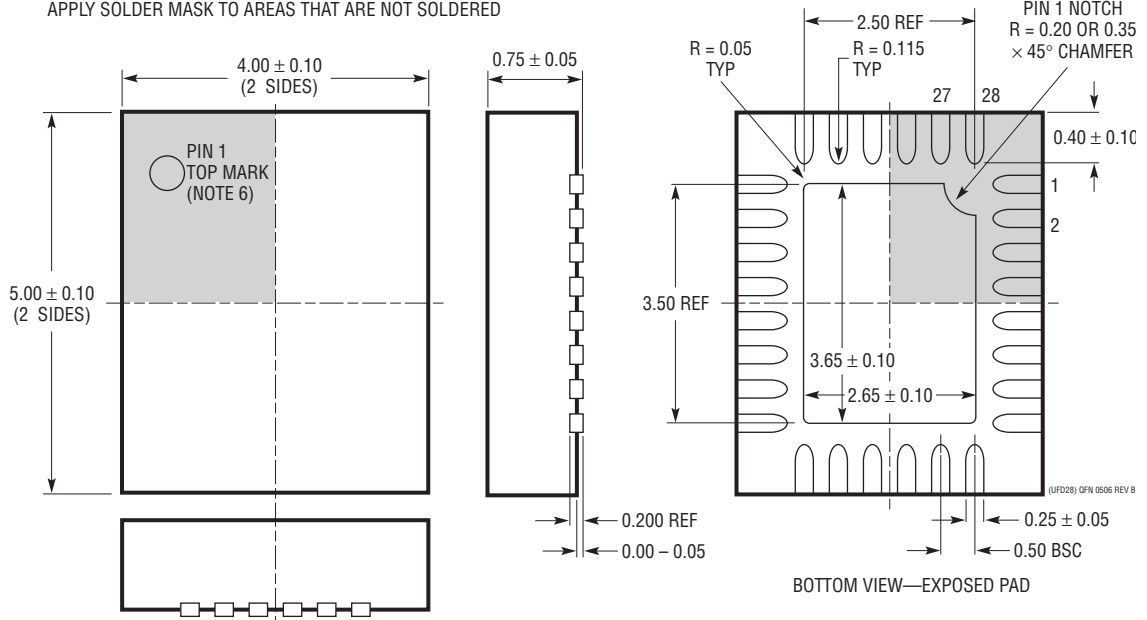

- NOTE:
1. DRAWING PROPOSED TO BE MADE A JEDEC PACKAGE OUTLINE MO-220 VARIATION (WXXX-X).
 2. DRAWING NOT TO SCALE
 3. ALL DIMENSIONS ARE IN MILLIMETERS
 4. DIMENSIONS OF EXPOSED PAD ON BOTTOM OF PACKAGE DO NOT INCLUDE MOLD FLASH. MOLD FLASH, IF PRESENT, SHALL NOT EXCEED 0.15mm ON ANY SIDE
 5. EXPOSED PAD SHALL BE SOLDER PLATED
 6. SHADED AREA IS ONLY A REFERENCE FOR PIN 1 LOCATION ON THE TOP AND BOTTOM OF PACKAGE

REVISION HISTORY

REV	DATE	DESCRIPTION	PAGE NUMBER
A	04/10	Corrected Pin Names for FE Package in Pin Configuration Section	2

TYPICAL APPLICATION

Triple Buck-Boost Mode 100mA × 4 LED Driver

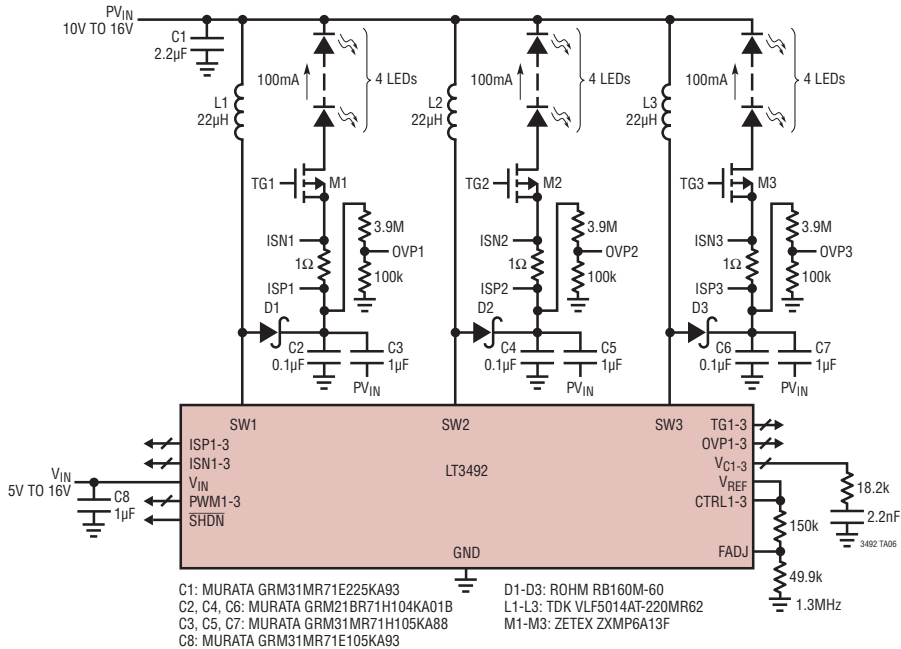

3000:1 PWM Dimming at 100Hz

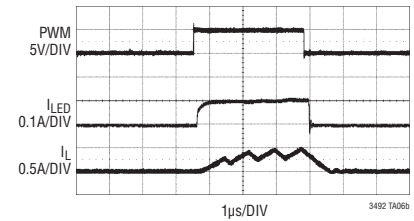

RELATED PARTS

PART NUMBER	DESCRIPTION	COMMENTS
LT3496	Triple 0.75A, 2.1MHz, 45V LED Driver	V_{IN} : 3V to 30V, $V_{OUT(MAX)}$ = 45V, Dimming = 3000:1, $I_{SD} < 1\mu A$, 4mm × 5mm QFN and TSSOP16E Packages
LT3474	36V, 1A (I_{LED}), 2MHz, Step-Down LED Driver	V_{IN} : 4V to 36V, $V_{OUT(MAX)}$ = 13.5V, True Color PWM Dimming = 400:1, $I_{SD} < 1\mu A$, TSSOP16E Package
LT3475	Dual 1.5A (I_{LED}), 36V, 2MHz Step-Down LED Driver	V_{IN} : 4V to 36V, $V_{OUT(MAX)}$ = 13.5V, True Color PWM Dimming = 3000:1, $I_{SD} < 1\mu A$, TSSOP20E Package
LT3476	Quad Output 1.5A, 36V, 2MHz High Current LED Driver with 1000:1 Dimming	V_{IN} : 2.8V to 16V, $V_{OUT(MAX)}$ = 36V, True Color PWM Dimming = 1000:1, $I_{SD} < 10\mu A$, 5mm × 7mm QFN Package
LT3477	3A, 42V, 3MHz Boost, Buck-Boost, Buck LED Driver	V_{IN} : 2.5V to 25V, $V_{OUT(MAX)}$ = 40V, Dimming = Analog/PWM, $I_{SD} < 1\mu A$, QFN and TSSOP20E Packages
LT3478/LT3478-1	4.5A, 42V, 2.5MHz High Current LED Driver with 3000:1 Dimming	V_{IN} : 2.8V to 36V, $V_{OUT(MAX)}$ = 42V, True Color PWM Dimming = 3000:1, $I_{SD} < 3\mu A$, TSSOP16E Package
LT3486	Dual 1.3A, 2MHz High Current LED Driver	V_{IN} : 2.5V to 24V, $V_{OUT(MAX)}$ = 36V, True Color PWM Dimming = 1000:1, $I_{SD} < 1\mu A$, 5mm × 3mm DFN and TSSOP16E Packages
LT3517	1.5A, 2.5MHz, 45V LED Driver	V_{IN} : 3V to 30V, $V_{OUT(MAX)}$ = 45V, Dimming = 3000:1, $I_{SD} < 1\mu A$, 4mm × 4mm QFN and TSSOP16E Packages
LT3518	2.3A, 2.5MHz, 45V LED Driver	V_{IN} : 3V to 30V, $V_{OUT(MAX)}$ = 45V, Dimming = 3000:1, $I_{SD} < 1\mu A$, 4mm × 4mm QFN and TSSOP16E Packages
LT3755/LT3755-1	40V _{IN} , 75V _{OUT} , Full Featured LED Controller	V_{IN} : 4.5V to 40V, $V_{OUT(MAX)}$ = 75V, True Color PWM Dimming = 3000:1, $I_{SD} < 1\mu A$, 3mm × 3mm QFN-16 and MS16E Packages
LT3756-1	100V High Current LED Controller	V_{IN} : 6V to 100V, $V_{OUT(MAX)}$ = 100V, True Color PWM Dimming = 3000:1, $I_{SD} < 1\mu A$, 3mm × 3mm QFN-16 and MS16E Packages
LTC®3783	High Current LED Controller	V_{IN} : 3V to 36V, $V_{OUT(MAX)}$ = Ext FET, True Color PWM Dimming = 3000:1, $I_{SD} < 20\mu A$, 5mm × 4mm QFN10 and TSSOP16E Packages

3492fa

Looking for pricing, stock, or lifecycle information?

Click below to explore more details on WIN SOURCE:

 [View LT3492IFE#PBF on WIN SOURCE](#)

 [Linear Technology](#) Information

Optimize Your Supply Chain with WIN SOURCE Solutions

-  Global Sourcing Solution
-  Obsolete Management
-  Cost Control Management
-  Shortage Management
-  Alternative Solution
-  Excess Inventory Management