



**THE DATASHEET OF
LT302001C**



Fuse Blocks

General Information



Fuse Block Selection

The following guidelines should help simplify the selection of proper fuse blocks:

1. Determine the system voltage

Since fuses are selected on the basis of system voltage, fuse blocks are selected to match the voltage rating of the fuse.

2. Determine the design short-circuit current

Available and/or design short-circuit current is an important consideration when determining the class of fuse and fuse blocks to use. If available short-circuit current cannot be determined, or if it will vary with equipment location, select fuses with a 200,000 ampere interrupting rating (A.I.R.) and mating fuse blocks with a withstand rating of 200,000 amperes for maximum safety.

Class H fuse blocks will accept Class H or K5 fuses (which have an interrupting rating of up to 50,000 amperes) and Class R fuses (which have a 200,000 A.I.R.). To prevent the possibility of inserting a fuse with the incorrect interrupting rating, the use of Class R fuse blocks is recommended for use with Class R fuses. Use Class H fuse blocks with Class H or K5 fuses. These fuse blocks are dimensionally the same, but the Class R fuse blocks incorporate a rejection feature which allows only Class R fuses to be inserted.

3. Determine the type and ampere rating of the fuse to be used

In addition to voltage and interrupting rating as discussed above, the fuse ampere rating, opening characteristics (fast acting or time-delay) and size are other important considerations in fuse selection. Once the fuse type is selected, the mating fuse block can be chosen. Fuse blocks are available in 30, 60, 100, 200, 400 and 600 amp ratings, and may be used with a fuse rated at the corresponding ampere rating or below. For example, a fuse block rated at 30 amperes may be used with a fuse rated from 0 to 30 amperes.

4. Determine if NEC, CSA, UL, or other requirements are applicable

If fuse blocks will be installed in equipment to be submitted for agency approval, the requirements should be obtained from the approving agency in advance of fuse and fuse block selection.

5. Select the type of wire termination

A choice of three types of wire termination is available:

- a) Screw* — for use with spade lugs or ring terminals.
- b) Screw with Pressure Plate* — for use with solid or stranded wire without terminal. Recommended where vibration will be a factor.
- c) Box Lug — the most durable. For use with all types of solid wire and Class B and Class C stranded wire. Not for use with welding cable or other rope-stranded conductors.

* 1/4" Quick Connect terminals rated for up to 20A are available on the Midget and Class CC fuse blocks.

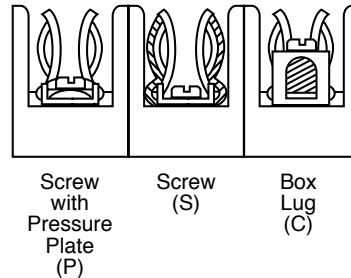

6. Decide on the number of poles in each block

The number of poles for each set of fuses is determined by the characteristics of the circuit. The option to gang individual fuse blocks into long strips will be determined by the available space and by the type of wire being used.

7. Determine if fuse clips need to be reinforced

Fuse clips may have a tendency to lose some of their tension over a period of time. This may be prevented by specifying reinforced fuse clips. Reinforced clips are standard on certain fuse blocks (see individual product pages).

Ordering Information

The Littelfuse fuse block part number consists of 6 or 7 components, as shown below and in the individual fuse block data tables.

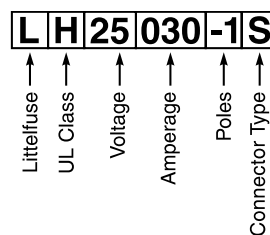

For all Class R, H, J, T and 15, 20 & 60A Class G Fuse Blocks

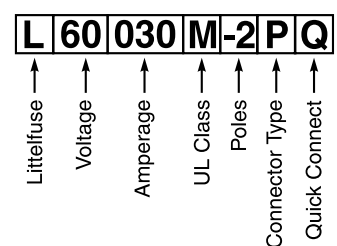

For all Class CC, Midget and 30A Class G Fuse Blocks

Class T Fuse Blocks

300 and 600 Volt



Features/Benefits

Bases are molded phenolic. To provide a low resistance connection and long-range reliability, steel reinforcing springs are supplied as standard. Larger blocks employ an integral heat sink for maximum heat dissipation.

Specifications

- Voltage Ratings:** 300 Volts AC
600 Volts AC
- Ampere Ratings:** 0 – 600 amperes
- Approvals:** UL Listed (File No. E14721)
CSA Certified (File No. LR73091)

Recommended Fuses

JLLN (300V) and JLLS (600V) series fuses
300 and 600 volt fuse blocks are designed for use with miniaturized Class T fuses. Class T fuses are very fast acting, current-limiting, and approximately one-third the size of electrically comparable Class RK1 fuses.

Class T 300V

Amp Rating	No. of Poles	Catalog Number	Connector Type (Add Suffix Shown)		Maximum Wire Size
			Screw	Box Lug	
30	2	LT30030-2		CR	S = #10 CU
	3	LT30030-3		CR	C = #2 CU
60	2	LT30060-2		CR	C = #2 CU-AL
	3	LT30060-3		CR	
	4	LT30060-4		CR	
100	1	LT30100-1		C	#2/0 CU-AL
	2	LT30100-2		C	
	3	LT30100-3		C	
200	1	LT30200-1		C	250 MCM CU-AL
400	1	LT30400-1		C	(2) 250 MCM CU-AL
600	1	LT30600-1		C	(2) 500 MCM CU-AL

Note: Reinforcing springs standard on all 300 volt Class T fuse blocks up to 100 amperes. 300 volt Class T blocks 200 amperes and larger have stud mountings.

Class T 600V

Amp Rating	No. of Poles	Catalog Number	Connector Type (Add Suffix Shown)		Maximum Wire Size
			Screw	Box Lug	
30	1	LT60030-1	SR	CR	S = #10 CU
	2	LT60030-2	SR	CR	C = #2 CU-AL
	3	LT60030-3	SR	CR	
60	1	LT60060-1		CR	C = #2 CU-AL
	2	LT60060-2		CR	
	3	LT60060-3		CR	
100	1	LT60100-1		C	#2/0 CU-AL
	2	LT60100-2		C	
	3	LT60100-3		C	
200	1	LT60200-1		C	250 MCM CU-AL
400	1	LT60400-1		C	(2) 250 MCM CU-AL
600	1	LT60600-1		C	(2) 500 MCM CU-AL

Note: Reinforcing springs standard on all 600 volt Class T fuse blocks up to 60 amperes. 600 volt Class T blocks 100 amperes and larger have stud mountings.

LT30030

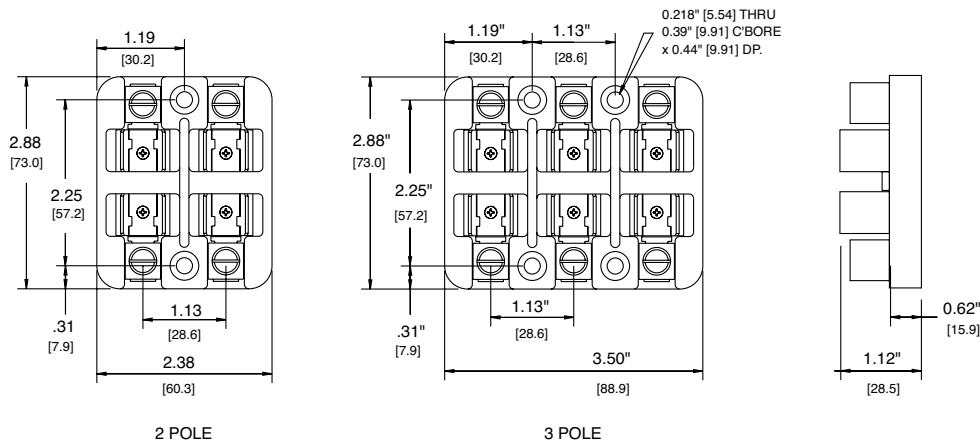

Class T Fuse Blocks

300 Volt

LT30060

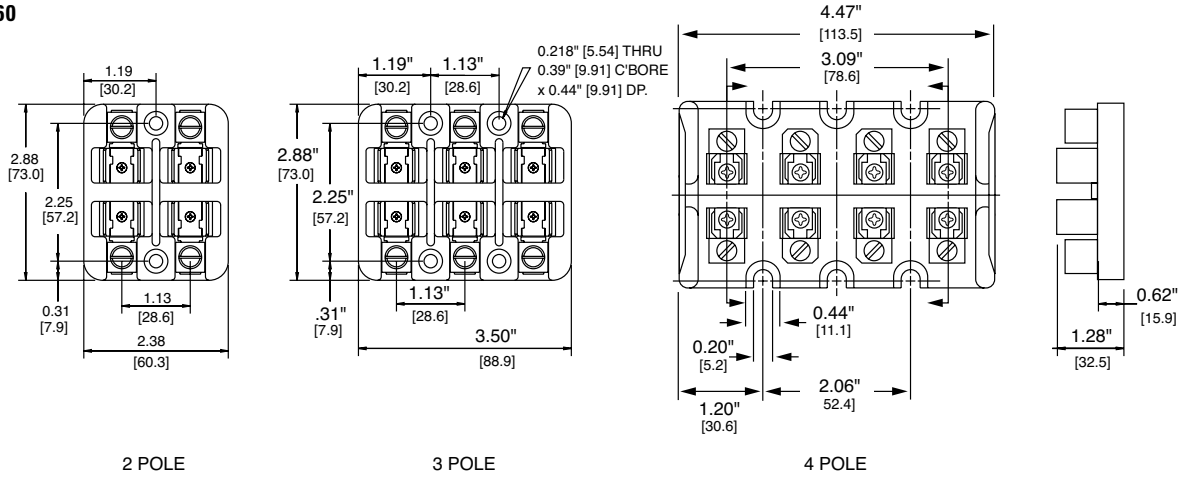

LT30100

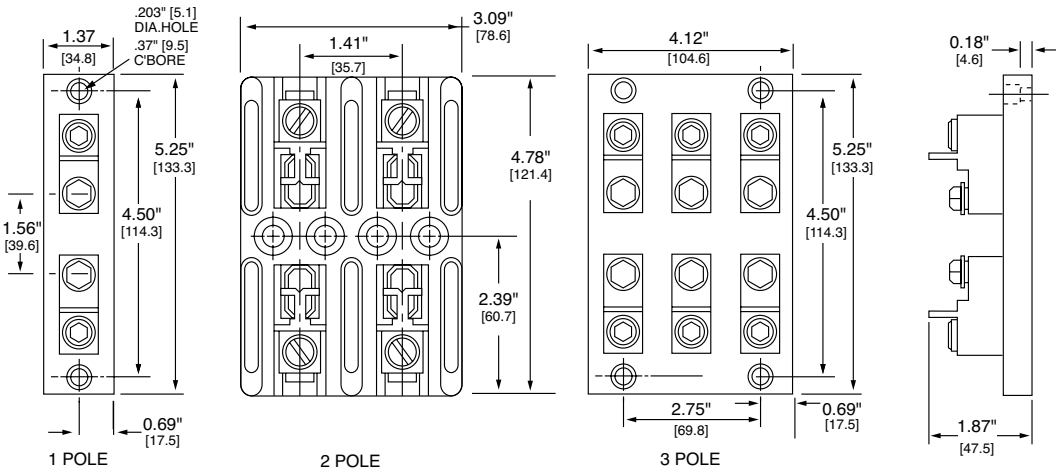

LT30200

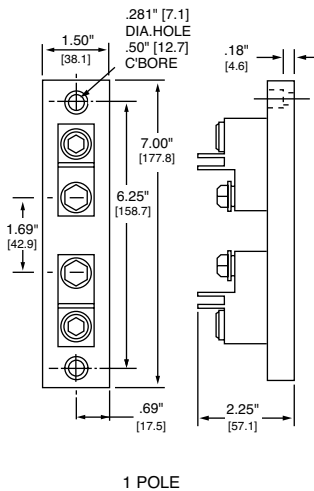

LT30400

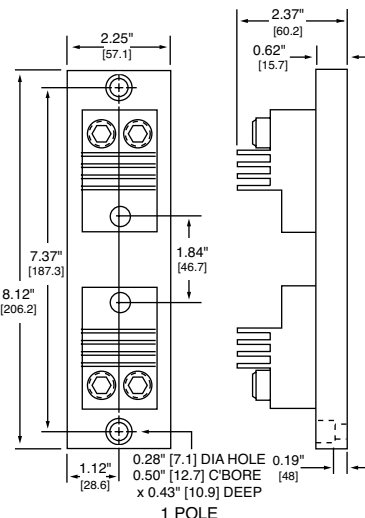

LT30600

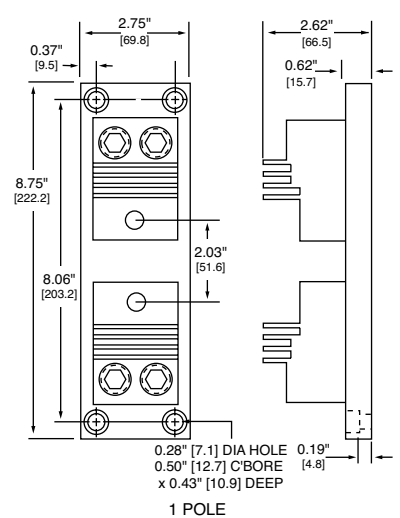

Class T Fuse Blocks

600 Volt

LT60030

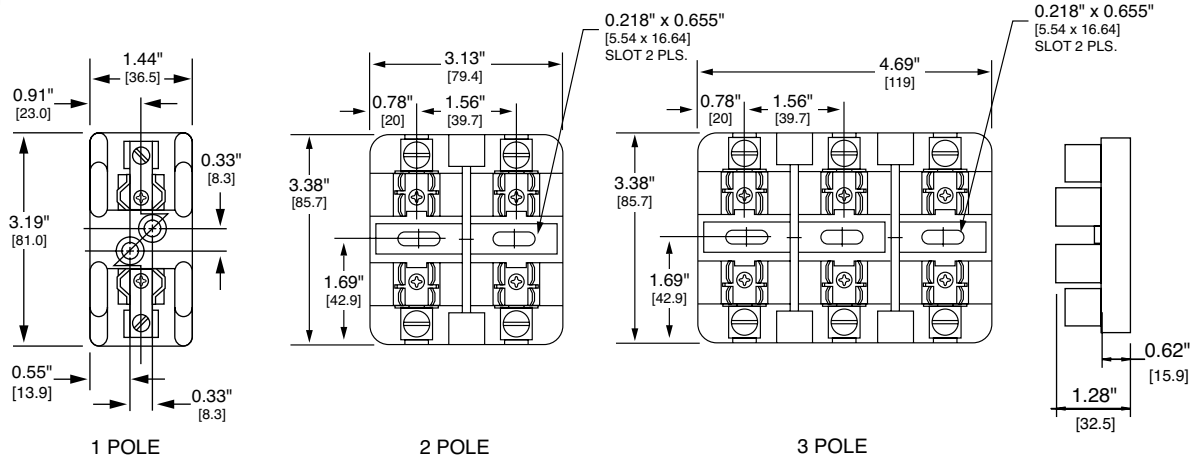

LT60060

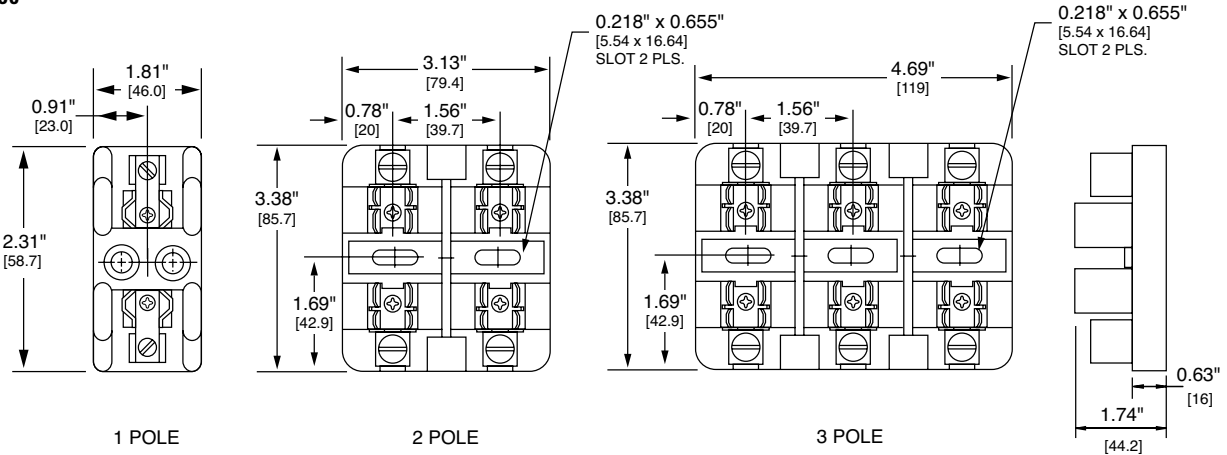

LT60100

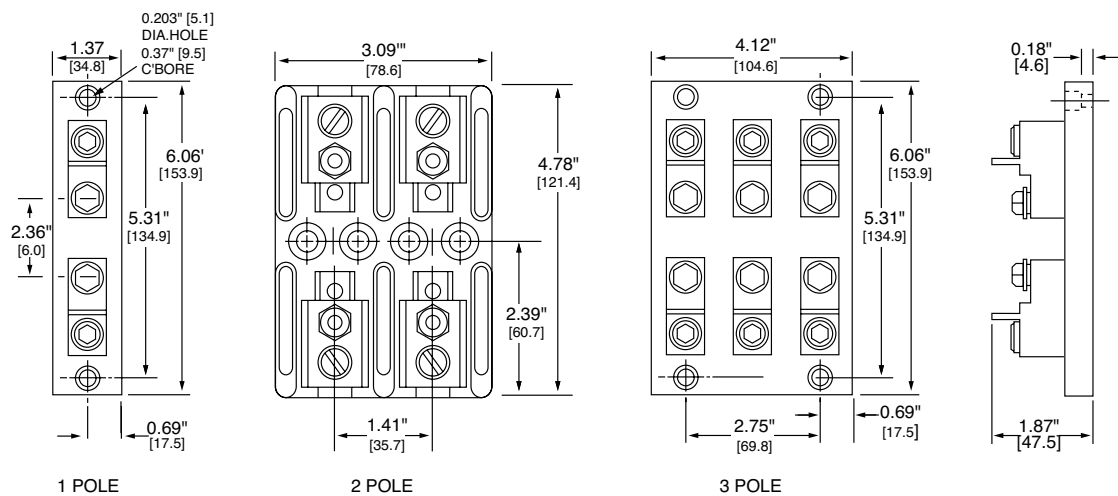

Class T Fuse Blocks

600 Volt

LT60200

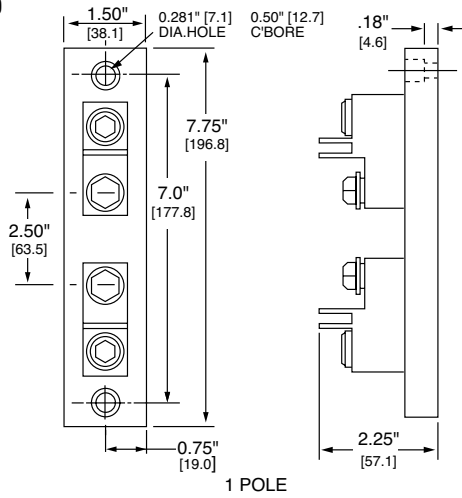

LT60400

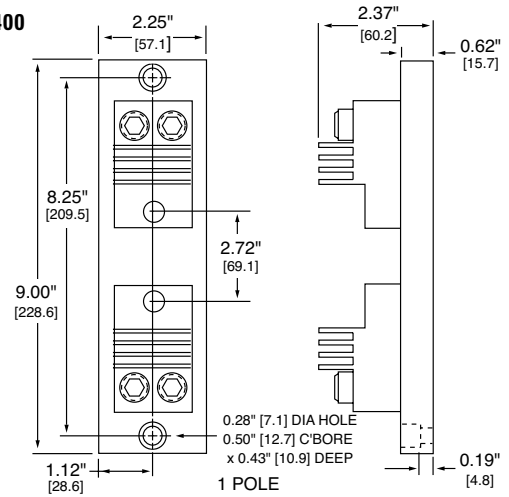

LT60600

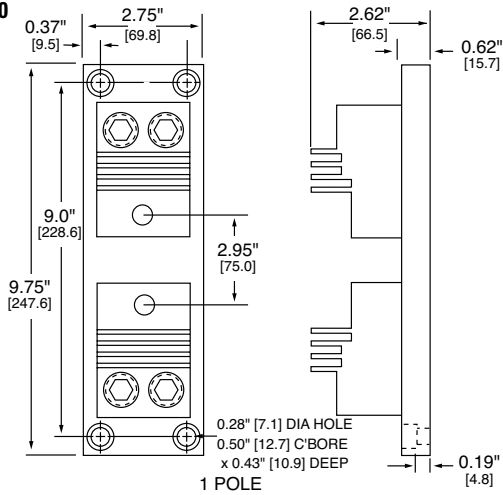







Looking for pricing, stock, or lifecycle information?

Click below to explore more details on WIN SOURCE:

 [View LT302001C on WIN SOURCE](#)

 [Littelfuse Inc. Information](#)

Optimize Your Supply Chain with WIN SOURCE Solutions

-  Global Sourcing Solution
-  Obsolete Management
-  Cost Control Management
-  Shortage Management
-  Alternative Solution
-  Excess Inventory Management