



**THE DATASHEET OF  
LT3003EMSE#PBF**



## FEATURES

- **3% LED Current Matching**
- **Up to 350mA Continuous Current per LED String**
- **Up to 3000:1 True Color PWM™ Dimming Range**
- **PWM Input Disconnects LED Strings**
- **Can Operate in Buck, Boost and Buck-Boost Modes**
- **Wide Input Range: 3V to 40V**
- **Overtemperature Outputs**
- **Works with LT1618, LT3477, LT3474, LT3475, LT3476, LTC®3783**
- **Thermally Enhanced 10-Pin MSOP Package**

## APPLICATIONS

- High Power LED Ballaster
- Automotive Lighting
- Video Cameras
- TFT LCD Backlighting

## DESCRIPTION

The LT<sup>®</sup>3003 drives three separate strings of LEDs up to 350mA/channel with 3% accurate current matching, resulting in uniform LED brightness and intensity. This approach is superior to conventional methods of running three separate channels with external ballast resistors requiring expensive factory calibration.

The LT3003 operates in boost, buck and buck-boost mode. A True Color PWM Dimming ratio of up to 3000:1 is achievable using a logic-level signal at the PWM pin for all modes without the need for external level-shifting circuitry. For applications with input supply above and below the output voltage of the LED strings, the LT3003 allows the LEDs to be returned to the input supply (buck-boost mode) instead of being limited to only SEPIC solutions.

The LT3003 is ideal for high power LED driver applications such as TFT LCD backlighting and heads-up displays. Additional overtemperature outputs allow appropriate system management for increased reliability.

The LT3003 is available in a small 10-pin MSE package.

*LT, LT, LTC and LTM are registered trademarks of Linear Technology Corporation. True Color PWM is a trademark of Linear Technology Corporation. All other trademarks are the property of their respective owners.*

## TYPICAL APPLICATION

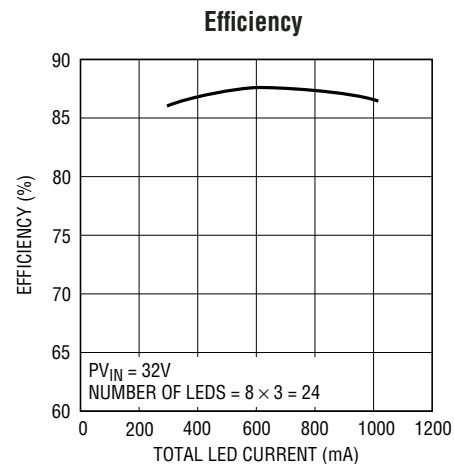
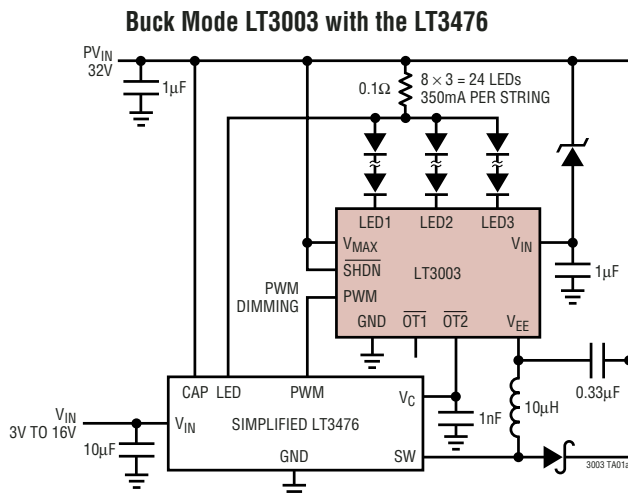

3003 TA01b

## ABSOLUTE MAXIMUM RATINGS

(Note 1)

$V_{IN}$ .....	40V
LED1, LED2, LED3 .....	48V
$V_{MAX}$ , SHDN .....	48V
$V_{IN} - V_{EE}$ .....	36V
$V_{EE}$ .....	36V
PWM .....	15V
OT1, OT2 .....	6V
Operating Junction Temperature Range (Notes 2, 3, 4) .....	-40°C to 125°C
Storage Temperature Range .....	-65°C to 150°C
Lead Temperature (Soldering, 10 sec) .....	300°C

## PACKAGE/ORDER INFORMATION

TOP VIEW

MSE PACKAGE  
10-LEAD PLASTIC MSOP  
 $T_{JMAX} = 125^{\circ}\text{C}$ ,  $\theta_{JA} = 35^{\circ}\text{C/W}$   
EXPOSED PAD (PIN 11) IS GND, MUST BE SOLDERED TO PCB

ORDER PART NUMBER	MSE PART MARKING
LT3003EMSE	LTCFF

**Order Options** Tape and Reel: Add #TR  
Lead Free: Add #PBF Lead Free Tape and Reel: Add #TRPBF  
Lead Free Part Marking: <http://www.linear.com/leadfree/>

Consult LTC Marketing for parts specified with wider operating temperature ranges.

## ELECTRICAL CHARACTERISTICS

The ● denotes the specifications which apply over the full operating temperature range, otherwise specifications are at  $T_A = 25^{\circ}\text{C}$ . PWM = 1V,  $V_{MAX} = 4\text{V}$ ,  $V_{IN} = 3\text{V}$ ,  $V_{EE} = 0\text{V}$ ,  $I_{LED2} = 100\text{mA}$ , OT1 = OT2 = Open, SHDN =  $V_{IN}$ .

PARAMETER	CONDITIONS	MIN	TYP	MAX	UNITS
$V_{IN}$ Operational Input Voltage	$V_{EE} = 0\text{V}$ , $I_{LED1,2,3} = 100\text{mA}$ $V_{EE} = 4\text{V}$ , $I_{LED1,2,3} = 100\text{mA}$	● 3		36 40	V V
Minimum ( $V_{IN} - V_{EE}$ )	$V_{EE} = 0\text{V}$ to 36V		2.7	3	V
$V_{IN}$ Quiescent Current	PWM = 1V, $I_{LED1,2,3} = 100\text{mA}$ PWM = 0V, $V_{LED1} = V_{LED2} = V_{LED3}$		10.5 470	600	mA $\mu\text{A}$
$V_{IN}$ Shutdown Current	SHDN = 0V, $I_{LED1,2,3} = 0\text{mA}$	2	4	10	$\mu\text{A}$
$V_{MAX}$ Quiescent Current	PWM = 1V, $I_{LED2} = 100\text{mA}$ PWM = 0V, $V_{LED1} = V_{LED2} = V_{LED3}$		55 20	90 300	$\mu\text{A}$ nA
SHDN Pin Threshold	$I_{LED2} = 100\text{mA}$ , $V_{LED1} = V_{LED2} = V_{LED3}$	● 0.25	0.7	1	V
LED Current Matching	$I_{LED2} = 350\text{mA}$ , $V_{LED1} = V_{LED2} = V_{LED3}$	-3	0	+3	%
$ I_{LED2} - I_{LED1} $ , $ I_{LED2} - I_{LED3} $ LED Current Matching with LED Pin Voltage Mismatch	$I_{LED2} = 350\text{mA}$ , ( $ V_{LED2} - V_{LED1}  +  V_{LED2} - V_{LED3} $ ) = 700mV	-3.5	0.5	+3.5	%
LED Pin Voltage	$I_{LED2} = 100\text{mA}$	0.7	0.8	0.9	V
LED1, LED2, LED3 Maximum Current	$V_{LED1,2,3} < 1.5\text{V}$	375	500	550	mA
LED1, LED2, LED3 Maximum Leakage Current	PWM = 0V, $V_{LED1,2,3} = 48\text{V}$		0.1	1	$\mu\text{A}$
PWM Switching Threshold	$I_{LED1,2,3} = 100\text{mA}$	● 0.3	0.5	0.7	V
Turn-On Delay (PWM On to $I_{LED}$ On)	PWM = 0V to 1V, $I_{LED} > 50\text{mA}$		2		$\mu\text{s}$
$V_{EE}$ Pin Current in Buck Mode	PWM = 0V, $V_{MAX} = 40\text{V}$ , $V_{IN} = 39\text{V}$ , $V_{EE} = 36\text{V}$		0.1	1	$\mu\text{A}$
Overtemperature Sense Point (OT1, OT2)	(Note 4)		125		$^{\circ}\text{C}$
Overtemperature Hysteresis Point	(Note 5)		-6° from Overtemp Sense Point		$^{\circ}\text{C}$
OT1 Pull-Down Current	OT1 = 0.3V (Note 4)	100			$\mu\text{A}$

**ELECTRICAL CHARACTERISTICS** The ● denotes the specifications which apply over the full operating temperature range, otherwise specifications are at  $T_A = 25^\circ\text{C}$ . PWM = 1V,  $V_{\text{MAX}} = 4\text{V}$ ,  $V_{\text{IN}} = 3\text{V}$ ,  $V_{\text{EE}} = 0\text{V}$ ,  $I_{\text{LED2}} = 100\text{mA}$ ,  $\text{OT1} = \text{OT2} = \text{Open}$ ,  $\text{SHDN} = V_{\text{IN}}$ .

PARAMETER	CONDITIONS	MIN	TYP	MAX	UNITS
$\text{OT2}$ Pull-Down Current	$\text{OT2} = 0.3\text{V}$ (Note 4)	300			$\mu\text{A}$
$\text{OT1}$ , $\text{OT2}$ Leakage Current	$\text{OT1} = \text{OT2} = 5\text{V}$			1	$\mu\text{A}$

**Note 1:** Stresses beyond those listed under Absolute Maximum Ratings may cause permanent damage to the device. Exposure to any Absolute Maximum Rating condition for extended periods may affect device reliability and lifetime.

**Note 2:** The LT3003E is guaranteed to meet performance specifications from  $0^\circ\text{C}$  to  $85^\circ\text{C}$  junction temperature. Specifications over the  $-40^\circ\text{C}$  to  $125^\circ\text{C}$  operating junction temperature range are assured by design, characterization and correlation with statistical process controls.

**Note 3:** This IC includes overtemperature protection that is intended to protect the device during momentary overload conditions. Junction temperature will exceed  $125^\circ\text{C}$  when overtemperature protection is active. Continuous operation above the specified maximum operating junction temperature may impair device reliability.

**Note 4:** Correlation to static test at  $T_A = 25^\circ\text{C}$ .

**Note 5:** Guaranteed by design.

**TYPICAL PERFORMANCE CHARACTERISTICS**  $T_A = 25^\circ\text{C}$  unless otherwise noted.

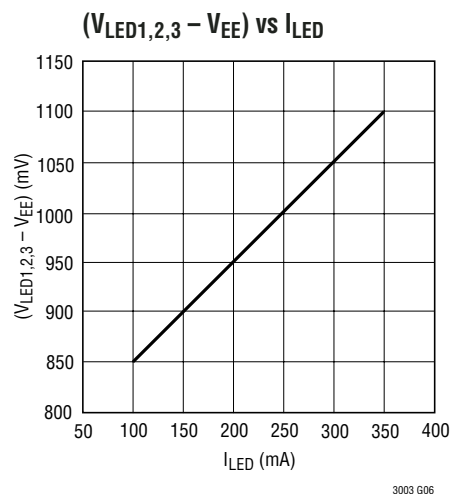
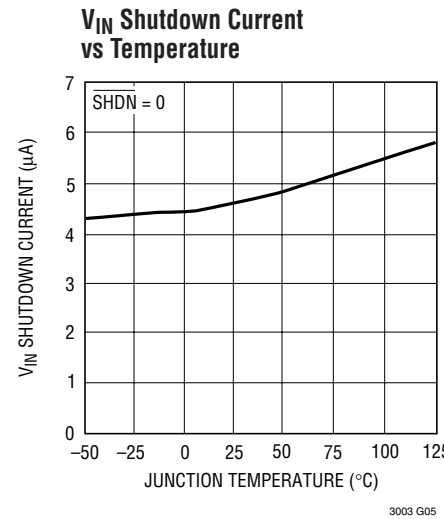
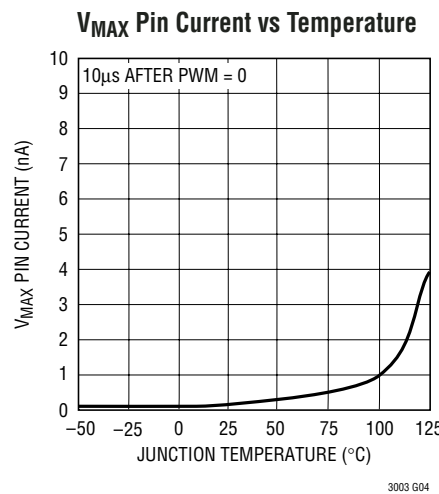
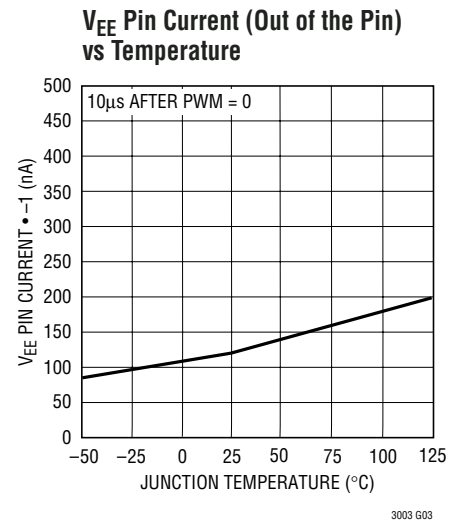
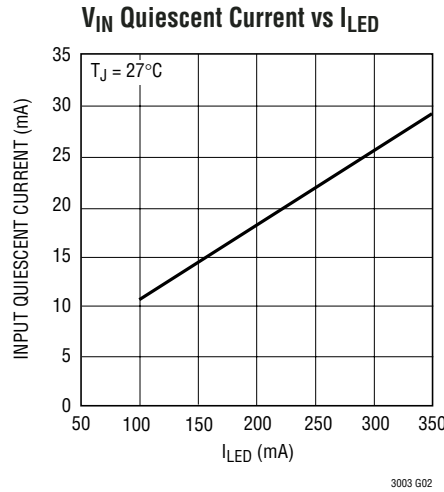
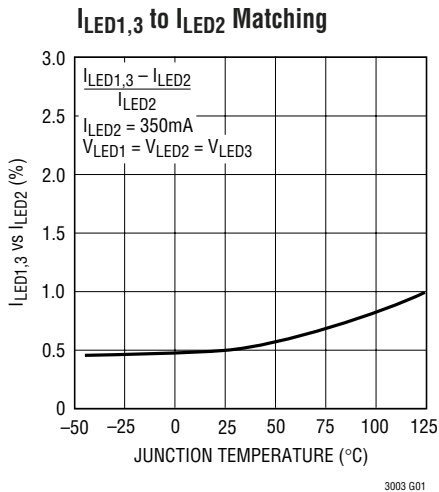

**TYPICAL PERFORMANCE CHARACTERISTICS**  $T_A = 25^\circ\text{C}$  unless otherwise noted.

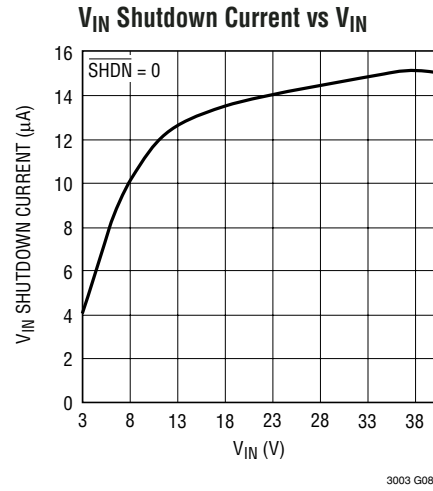
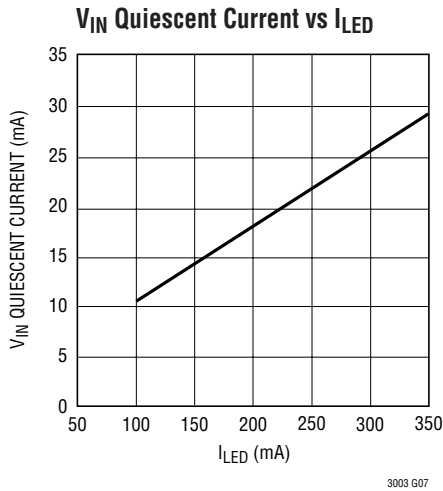

**PIN FUNCTIONS**

**LED1 (Pin 1):** Controlled current input for a string of LEDs with a cathode lead connected to the pin. Connect the first string of LEDs to this pin.

**LED2 (Pin 2):** Controlled current input for a string of LEDs with a cathode lead connected to the pin. Connect the second string of LEDs to this pin.

**LED3 (Pin 3):** Controlled current input for a string of LEDs with a cathode lead connected to the pin. Connect the third string of LEDs to this pin.

**V<sub>MAX</sub> (Pin 4):**

- Boost: Connect to V<sub>OUT</sub>
- Buck Mode: Connect to Input Supply
- Buck-Boost Mode: Connect to V<sub>OUT</sub>

**V<sub>IN</sub> (Pin 5):** Input Supply, Upper Rail. This pin must be locally bypassed with a capacitor to ground. V<sub>IN</sub> powers the internal control circuitry.

- Boost: Connect to Input Supply
- Buck Mode: Connect to Input Supply
- Buck-Boost Mode: Connect to V<sub>OUT</sub>

**PWM (Pin 6):** Input Pin for PWM Dimming Control. A PWM signal above 0.5V (on threshold) turns the LT3003

channels on. A PWM signal below 0.5V completely disconnects each LED string. If the application does not require PWM dimming, then the PWM pin can be left either open (an internal 10µA source current pulls PWM high) or it can be connected to a supply between 0.5V to 15V.

**OT1 (Pin 7):** Overtemperature Output. OT1 pulls 100µA from the pin when the junction temperature exceeds 125°C. The part has to cool down by 6°C for the flag to reset; ideal for providing an overtemperature flag to the system microprocessor.

**OT2 (Pin 8):** Overtemperature Output. OT2 Pulls 300µA from the pin when the junction temperature exceeds 125°C. The part has to cool down by 6°C for the flag to reset; ideal for connecting to the switching regulator g<sub>m</sub> error amplifier output to defeat switching.

**SHDN (Pin 9):** Micropower Shutdown Pin. Below 0.7V shuts down the IC. Typically I<sub>VIN</sub> = 4µA for SHDN = 0V.

- Boost: Connect to System Shutdown Signal or V<sub>IN</sub>
- Buck Mode: Connect to System Shutdown Signal or V<sub>IN</sub>
- Buck-Boost Mode: If PWM dimming, connect to PWM (Pin 6); if no PWM dimming, connect to system shutdown signal or V<sub>IN</sub>

## PIN FUNCTIONS

**V<sub>EE</sub> (Pin 10):** Lower Rail.

- Boost: Connect to System Ground
- Buck Mode: Connect to Inductor
- Buck-Boost Mode: Connect to Input Supply

**Exposed Pad (Pin 11):** GND. The ground for the IC should be soldered to a continuous copper ground plane under the LT3003 die. Soldering the Exposed Pad to the copper ground plane under the device will reduce thermal resistance and increase the power capability of the LT3003.

## BLOCK DIAGRAM

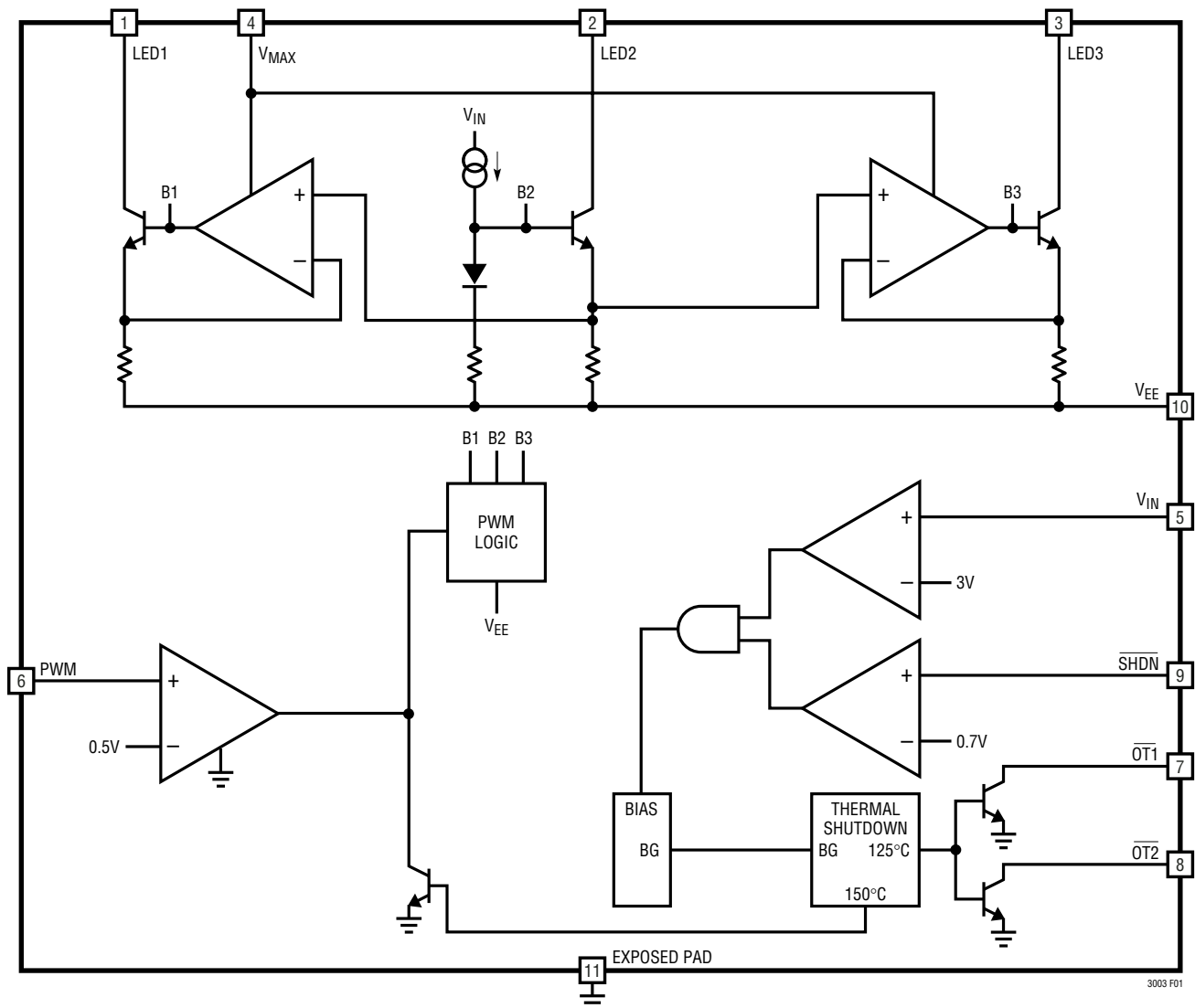

Figure 1. Block Diagram

## OPERATION

The LT3003 is an easy-to-use 3-channel LED ballaster. It allows three strings of LEDs to be driven in parallel with accurate LED current matching. A PWM pin is also provided allowing LED currents to be turned on and off at very low duty cycles for very wide LED dimming ranges. For reliable system thermal management, two output flags,  $\overline{OT1}$  and  $\overline{OT2}$ , are provided to indicate when the junction temperature exceeds 125°C.

The Block Diagram in Figure 1 best illustrates the features of LT3003. The LT3003 internal bias circuitry is turned on when  $V_{IN} > 3V$  and  $\overline{SHDN} > 0.7V$ . For LED current to be active in each channel, the PWM pin must exceed 0.5V.  $V_{MAX}$  should be connected to the highest supply in the application (see various application modes of boost, buck, buck-boost in the Typical Applications section).

The LT3003 ballasting feature is achieved by using the current monitored in the LED2 channel to control the current in channels LED1 and LED3. A servo loop exists for each channel LED1 and LED3 that compares the current in each channel to the LED2 reference channel. The current in LED2 channel is determined by the LED current programmed by the partner LED driver. Details of how LED current can be programmed by the partner IC are covered in the Typical Applications section using various ICs as LED drivers. Maximum fault current in each of the LT3003 LED pins is internally limited to 550mA. If any LED string experiences an open-circuit fault, all LED string currents are turned off.

The LT3003 PWM pin has unique level-shifting circuitry to allow a simple logic-level PWM signal to turn each LED pin current on and off regardless of the  $V_{EE}$  pin voltage. This allows very simple PWM dimming control of LED current without any need for external level-shifting components in buck mode and buck-boost mode applications. Care is taken to ensure low current (nano amps) in the  $V_{EE}$  and  $V_{MAX}$  pins 10 $\mu$ s after PWM low edge. This feature minimizes leakage currents in each application to maximize PWM dimming ratio. Details of PWM dimming and critical parameters are given in the Applications Information section PWM Dimming.

The LT3003 incorporates internal junction temperature sensing and provides two open-collector outputs,  $\overline{OT1}$  and  $\overline{OT2}$ , which become active low when junction temperature exceeds 125°C.  $\overline{OT1}$  is sized to pull 100 $\mu$ A and can be used as an input to the microprocessor for system thermal management.  $\overline{OT2}$  is sized to pull 300 $\mu$ A to defeat switching for most of LTC's LED drivers by pulling down the  $g_m$  error amplifier output. LT3003 is forced to a "zero LED current state" by a special internal protection circuit when junction temperature reaches 150°C.

To calculate the LT3003 junction temperature, see Thermal Calculations in the Applications Information section.

## APPLICATIONS INFORMATION

### Input Capacitor Selection

The LT3003 is typically driven from the same input voltage used for the partner LED driver IC. The LED driver and inductor govern the requirements for the input capacitor of the application. A ceramic input capacitor in the range of 1 $\mu$ F to 10 $\mu$ F works for most applications. In cases where the LT3003 input voltage is derived separately from the LED driver, a 1 $\mu$ F input capacitor works well.

### LED Current Matching

An LED driver programs the LED current and LT3003 actively ballasts three separate strings of LEDs. The currents in all three channels will be matched to better than  $\pm 3\%$ . To achieve best current matching,  $(V_{IN} - V_{EE})$  should be between 3V and 10V. A low  $(V_{IN} - V_{EE})$  also minimizes LT3003 internal power dissipation (see Thermal Calculation section for more information).

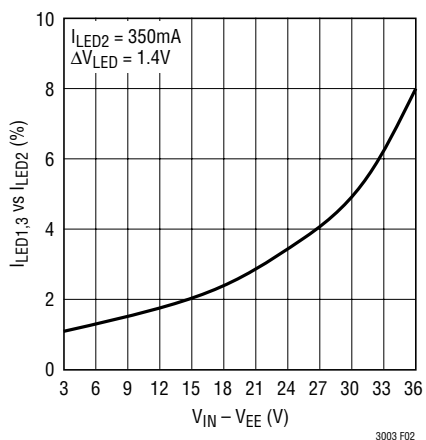

Figure 2. I<sub>LED</sub> Matching vs (V<sub>IN</sub> - V<sub>EE</sub>)

### LED Pin Current Range

The steady-state operational current range for each LED pin is between 100mA and 350mA. Internal protection circuitry limits absolute maximum pin current to 550mA.

### LED Open-Circuit Protection

If any LED string is open, then currents in all three channels reduce to zero. The driver chip, which supplies LED current, should have an overvoltage clamp to protect the LT3003 from high LED pin voltages.

### PWM Dimming

The LT3003 has a wide PWM dimming range for constant color LED dimming. PWM dimming is superior to analog dimming as it preserves true color quality. PWM dimming control with the LT3003 is achieved using a simple ground referenced PWM signal with a 0.5V on/off threshold. The LEDs operate at either programmed or zero current but their brightness changes with the PWM signal duty cycle. When PWM is low, LED strings are completely disconnected. In addition, the LT3003 switches to low power standby mode  $\sim 10\mu$ s after PWM low edge, resulting in higher system power efficiency.

For the widest dimming range, the PWM signal should be 100Hz. The human eye is typically sensitive to flickering below  $\sim 80$ Hz. Operating the PWM higher than 100Hz results in a reduced PWM dimming ratio.

Achieving high PWM dimming ratios require attention to circuit leakages, such as reverse bias leakage currents through the external Schottky. Hence, for high PWM dimming ratios, components should be chosen to minimize leakage currents.

If an application does not require PWM dimming, the PWM pin can be left open (unconnected) and an internal 10 $\mu$ A source current pulls PWM high.

### Boost PWM Dimming

The LT3003 supports up to a 3000:1 PWM dimming ratio with a 100Hz PWM dimming frequency. To achieve such high PWM ratios, leakages of the LED driver and other external components should be minimal.

### Buck Mode: PWM Dimming

The LT3003 supports up to a 3000:1 PWM dimming ratio in buck mode. The PWM dimming in buck mode is achieved by an architecture that allows the LT3003 power ground (V<sub>EE</sub>) to move with output capacitor voltage. PWM dimming control is achieved by a simple ground referenced PWM signal, eliminating the need for any external level-shift component.

High PWM dimming ratios require very low V<sub>EE</sub> and V<sub>MAX</sub> pin currents during the PWM off state. The LT3003

APPLICATIONS INFORMATION

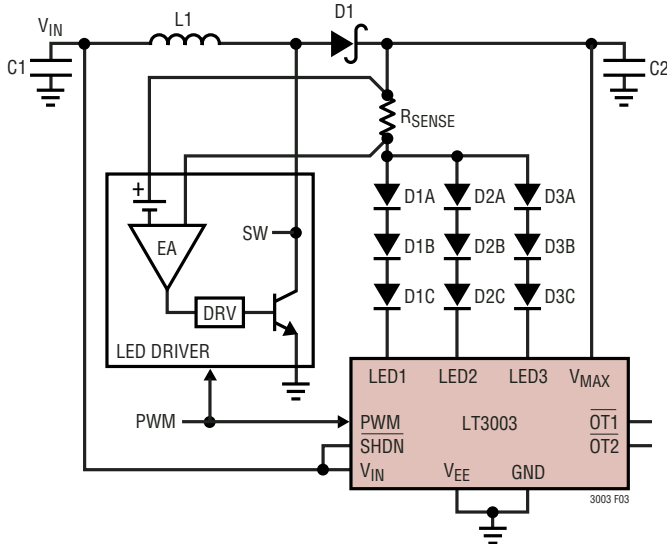

Figure 3. Boost Mode

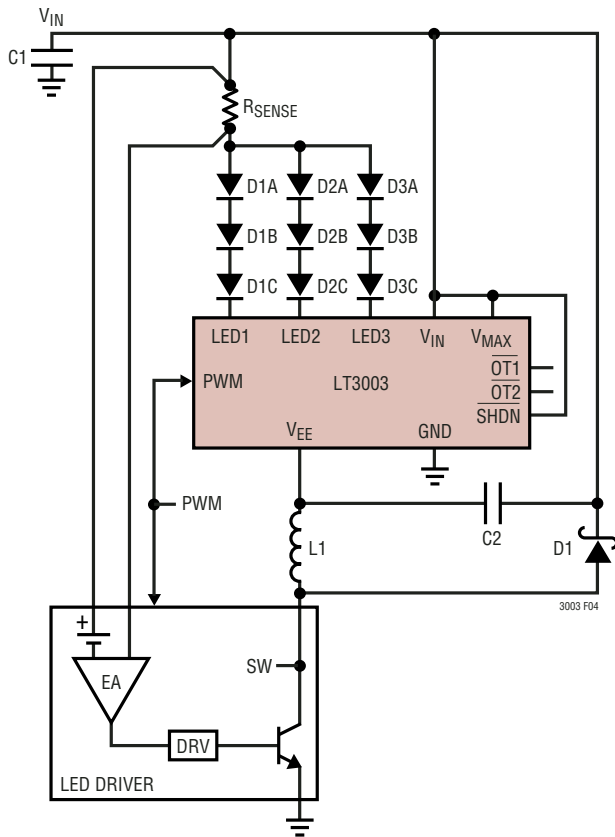

Figure 4. Buck Mode

uses novel circuit techniques to reduce  $V_{EE}$  and  $V_{MAX}$  pin currents to nano amp range  $\sim 10\mu s$  after PWM low edge. This preserves the output capacitor voltage and results in higher PWM dimming ratios.

Buck-Boost Mode: PWM Dimming

The LT3003 can also perform PWM dimming in buck-boost mode. The buck-boost configuration requires the PWM and SHDN pins to be tied together. This configuration can support up to a 2000:1 PWM dimming ratio.

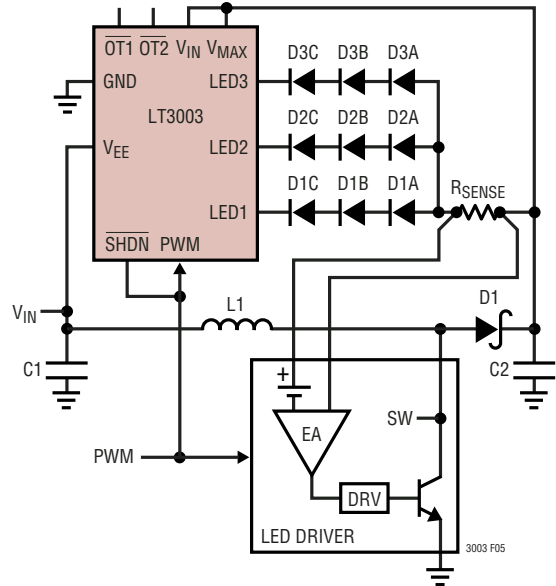

Figure 5. Buck-Boost Mode

Overtemperature Protection

The LT3003 incorporates internal junction temperature sensing and provides two open-collector outputs,  $\overline{OT1}$  and  $\overline{OT2}$ , which become active low when junction temperature exceeds  $125^{\circ}C$ . The active  $\overline{OT1}$  output can sink  $100\mu A$  of current and can be connected to system microprocessor. The active low  $\overline{OT2}$  output can sink  $300\mu A$  of current and can be connected to the switching regulator's  $g_m$  error amplifier output to defeat switching. The LT3003 has to cool down by  $6^{\circ}C$  ( $119^{\circ}C$ ) for  $\overline{OT1}$  and  $\overline{OT2}$  outputs to reset (collector outputs high).

## APPLICATIONS INFORMATION

In addition, LT3003 has an internal 150°C overtemperature protection circuitry that resets the chip to zero LED current mode. This prevents the chip from continuous operation at high temperature.

### Thermal Calculations

To maximize output power capability in an application without exceeding the LT3003 125°C maximum operational junction temperature, it is useful to be able to calculate power dissipation within the IC. The power dissipation within the LT3003 comes from four main sources: switch DC loss, switch loss due to LED  $V_{LED}$  mismatch and input quiescent current.

#### 1. Switch DC Loss:

$$P_{SW(DC)} = I_{LED} \cdot V_{LED} \cdot 3$$

(See  $(V_{LED1,2,3} - V_{EE})$  vs  $I_{LED}$  Typical Performance Characteristics graph.)

#### 2. Switch Loss due to $V_{LED}$ Mismatch:

$$P_{SW(\Delta V_{LED})} = \text{Total } V_{LED} \text{ mismatch} \cdot I_{LED}$$

#### 3. Input Quiescent Loss:

$$P_Q = (V_{IN} - V_{EE}) \cdot (I_Q - 1\text{mA}) + 1\text{mA} \cdot V_{IN}$$

$$I_Q = \frac{3 \cdot I_{LED}}{40} + 3\text{mA}$$

#### 4. Total Power Dissipation:

$$P_{TOT} = P_{SW(DC)} + P_{SW(\Delta V_{LED})} + P_Q$$

#### 5. LT3003 Junction Temperature:

$$T_J (\text{LT3003}) = T_A + \theta_{JA}(P_{TOT});$$

$$\theta_{JA}(P_{TOT}) = P_{TOT} \cdot 35^\circ\text{C/W}$$

### Example

$$V_{IN} = 3\text{V}; V_{EE} = 0\text{V}; I_{LED} = 350\text{mA/string};$$

$$\bullet I_Q = \frac{3 \cdot 350\text{mA}}{40} + 3\text{mA} = 29.25\text{mA}$$

Total  $V_{LED}$  mismatch = 1V:

- e.g., LED string 1 voltage drop = 6V;  
LED string 2 voltage drop = 5.7V;  
LED string 3 voltage drop = 5.3V

$$\bullet \text{Total } V_{LED} \text{ mismatch} = (6\text{V} - 5.7\text{V}) + (6\text{V} - 5.3\text{V}) = 1\text{V}$$

$V_{LED} = 1.1\text{V}$  at  $I_{LED} = 350\text{mA}$  (see  $(V_{LED} - V_{EE})$  vs  $I_{LED}$  Typical Performance Characteristics graph).

$$1. P_{SW(DC)} = 3 \cdot 350\text{mA} \cdot (1.1\text{V}) = 1.16\text{W}$$

$$2. P_{SW(LED)} = 1000\text{mV} \cdot 350\text{mA} = 350\text{mW}$$

$$3. P_Q = (3 - 0) \cdot (29.25 - 1)\text{mA} + 3 \cdot 1\text{mA} = 88\text{mW}$$

$$4. P_{TOT} = 1.1\text{W} + 350\text{mW} + 88\text{mW} \approx 1.6\text{W}$$

The LT3003 uses a thermally enhanced 10-lead MSE package. With proper soldering of the Exposed Pad to the underside of the package, combined with a full copper plane underneath the device, the thermal resistance ( $\theta_{JA}$ ) is about 35°C/W. For an ambient temperature of  $T_A = 25^\circ\text{C}$ , the junction temperature of the LT3003, for the example application described above, can be calculated as:

$$5. T_J = T_A + \theta_{JA} \cdot P_{TOT} = 25^\circ\text{C} + 35^\circ\text{C/W} \cdot 1.6\text{W} = 81^\circ\text{C}$$

### Minimizing LT3003 Internal Power Dissipation

The LT3003 requires at least 3V headroom between  $V_{IN}$  and  $V_{EE}$ . Hence, for systems with high system input voltage and low  $V_{EE}$  (such as running multiple series LEDs in a Buck Mode), it is beneficial to lower the level of  $V_{IN}$  pin voltage (LT3003 upper rail) with an external zener to reduce power dissipation in the chip. Therefore, it is recommended to limit  $(V_{IN} - V_{EE})$  to less than 10V. To achieve best performance,  $(V_{IN} - V_{EE})$  should equal 3V.

TYPICAL APPLICATIONS

1.05A Buck Mode LT3003 with the LT3476

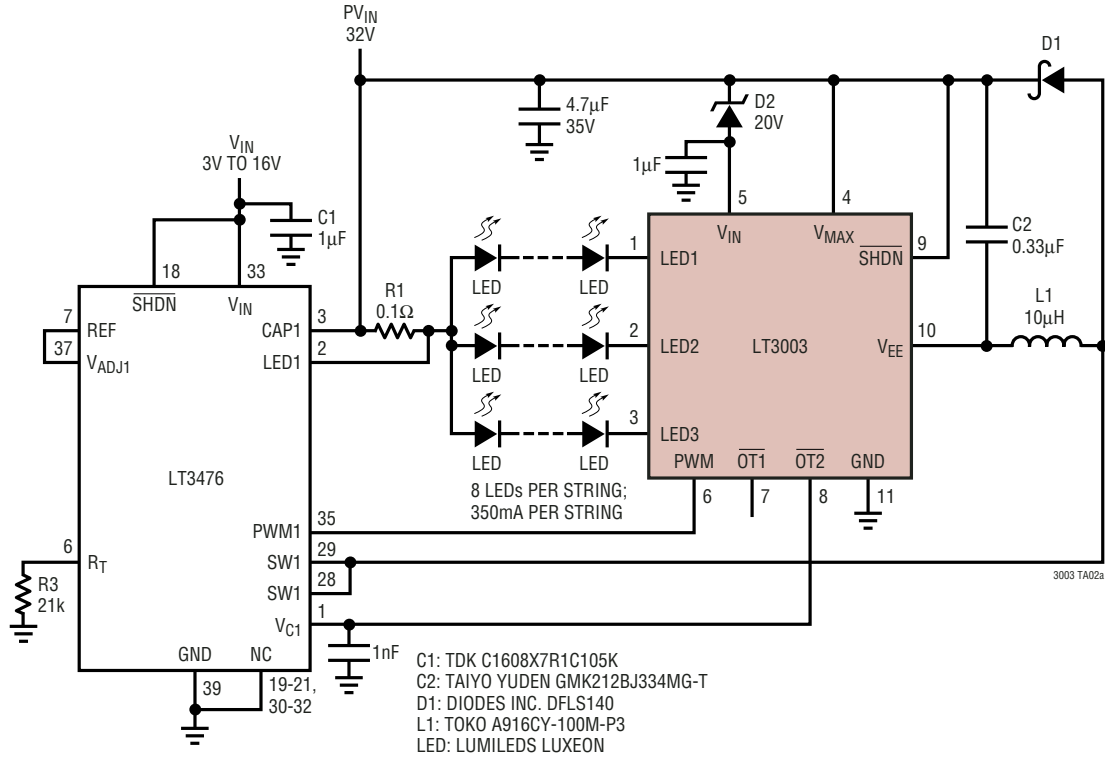

Efficiency

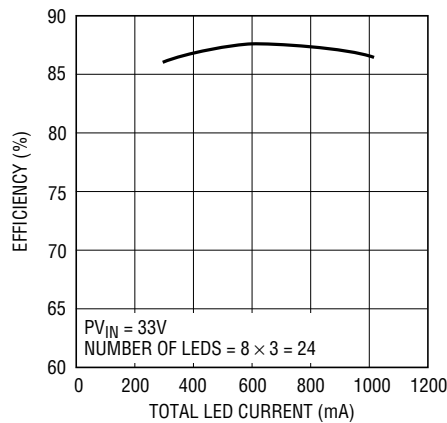

3003 TA02b

TYPICAL APPLICATIONS

330mA Boost LT3003 with the LT3477

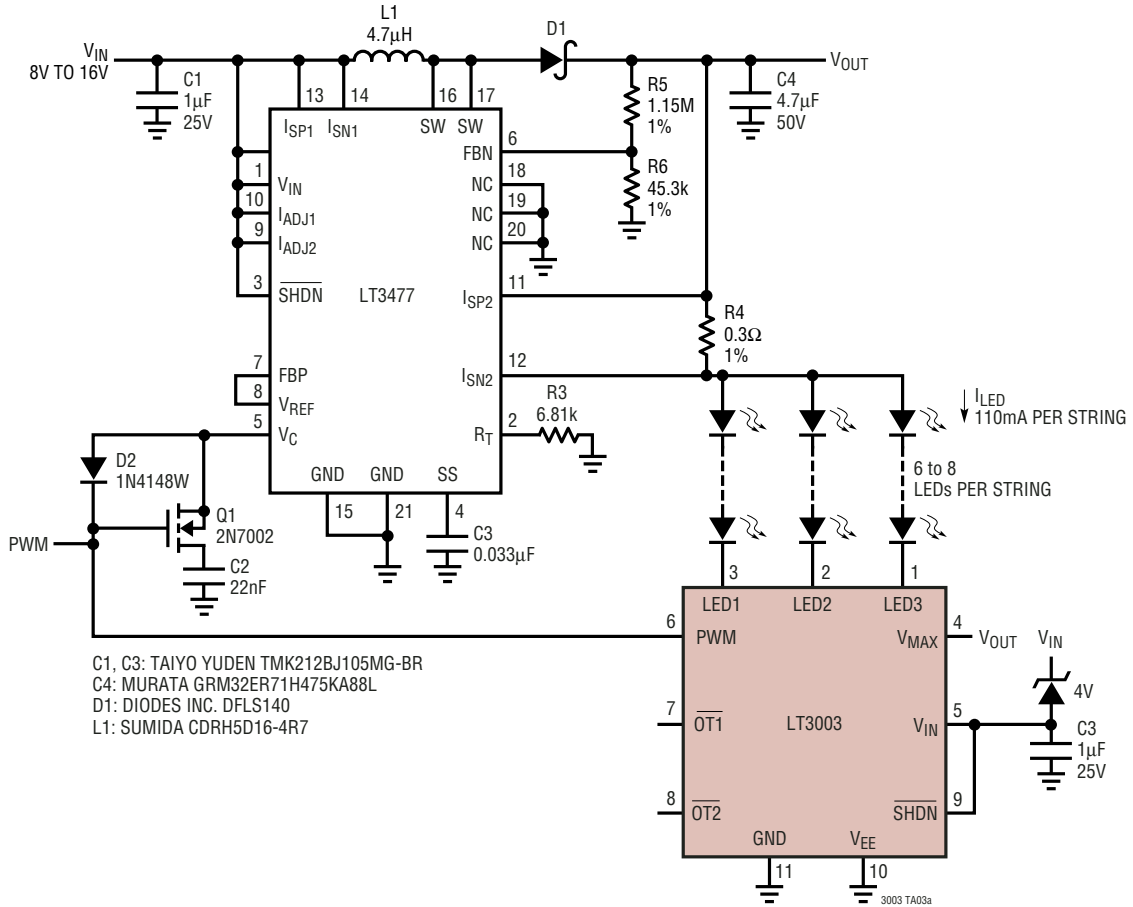

PWM Dimming

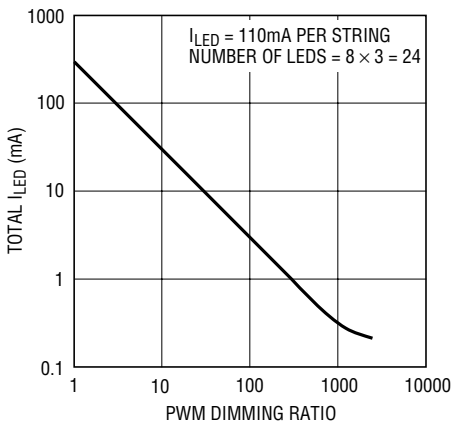

3003 TA03b

Efficiency

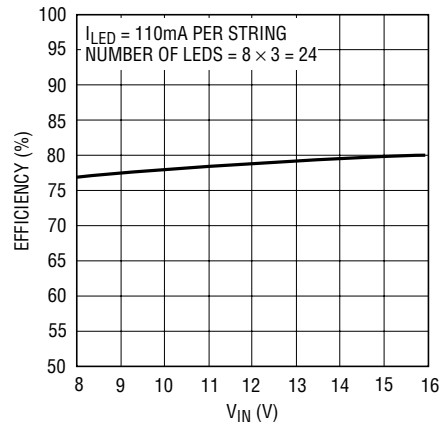

3003 TA03b

## TYPICAL APPLICATIONS

### 300mA Buck-Boost Mode LT3003 with the LT3477

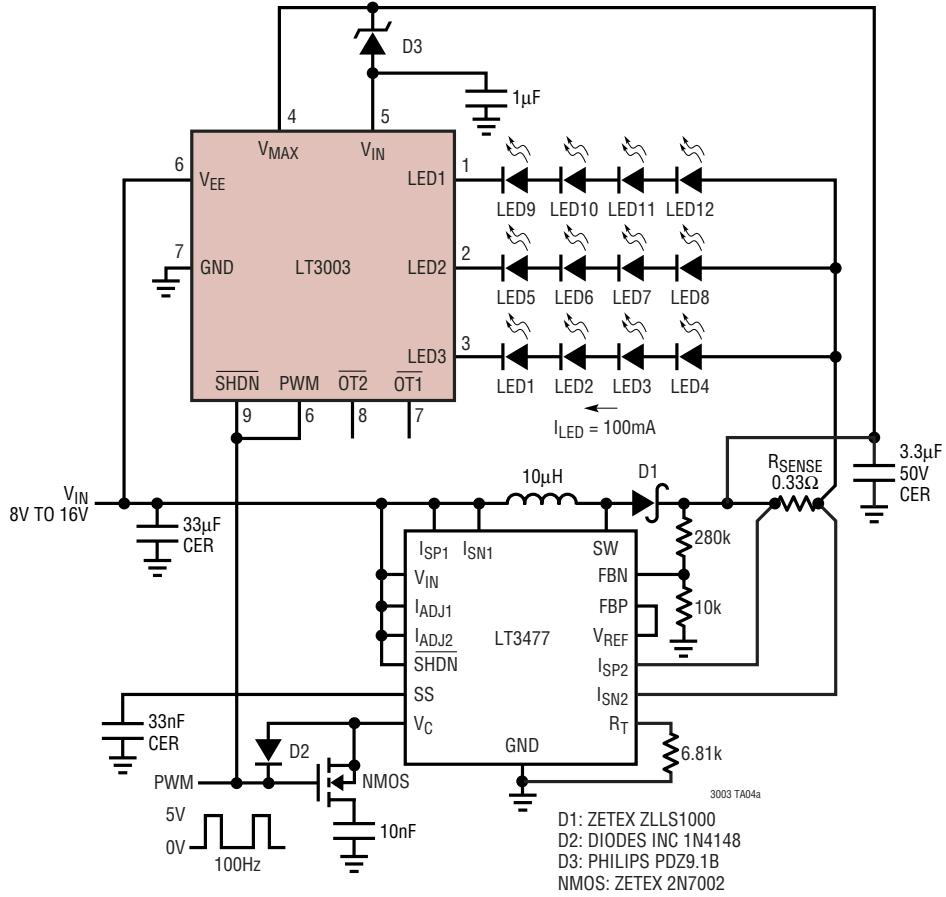

### Efficiency

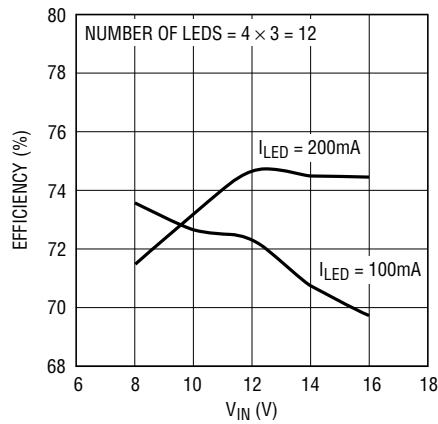

TYPICAL APPLICATIONS

1A Buck Mode LT3003 with the LT1618

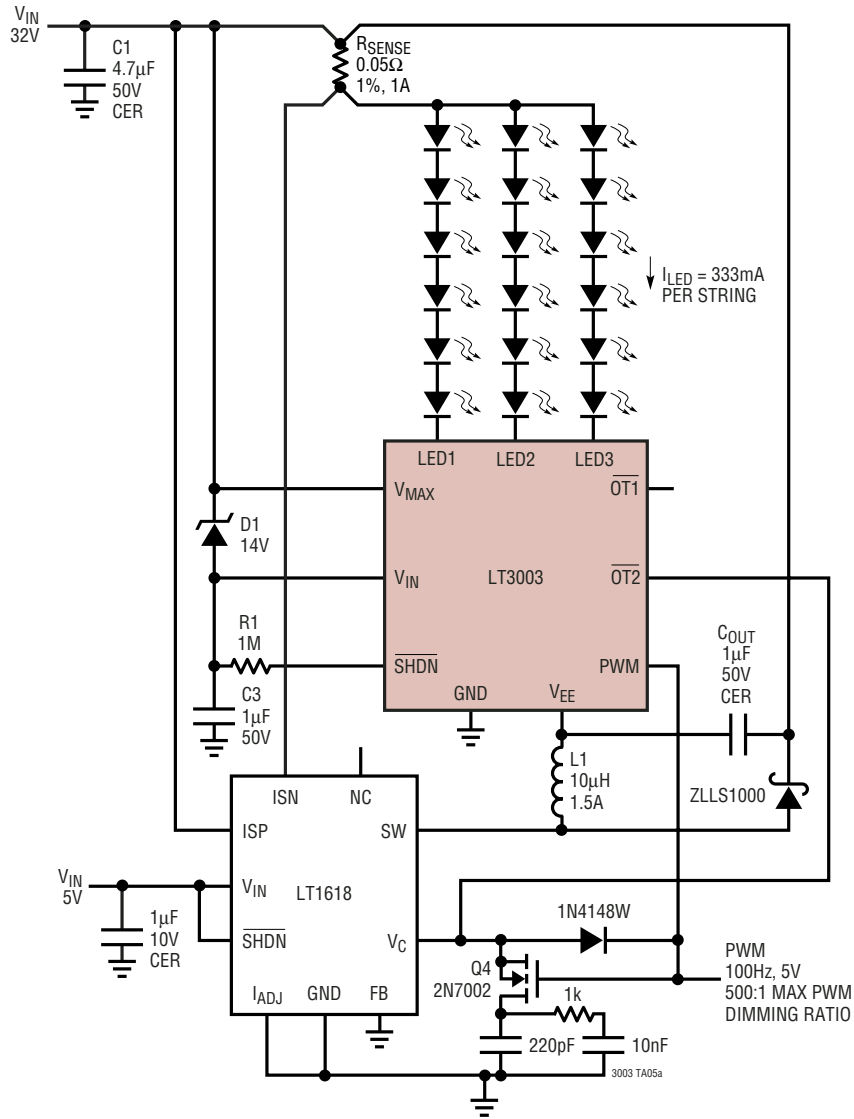

Efficiency

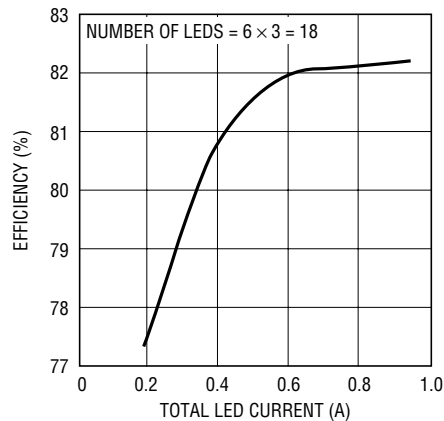

3003 TA05b

3003fa

## TYPICAL APPLICATIONS

1A Buck LT3003 with the LT3475



Efficiency

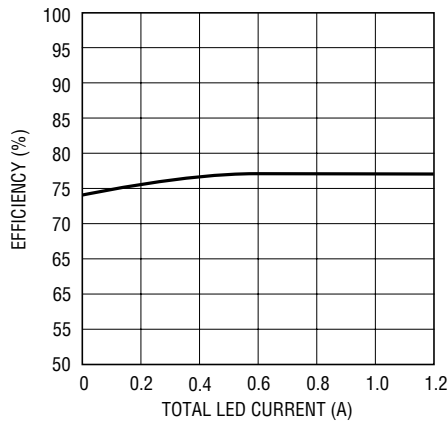

3003 TA06b

PACKAGE DESCRIPTION

**MSE Package**  
**10-Lead Plastic MSOP**  
 (Reference LTC DWG # 05-08-1664)

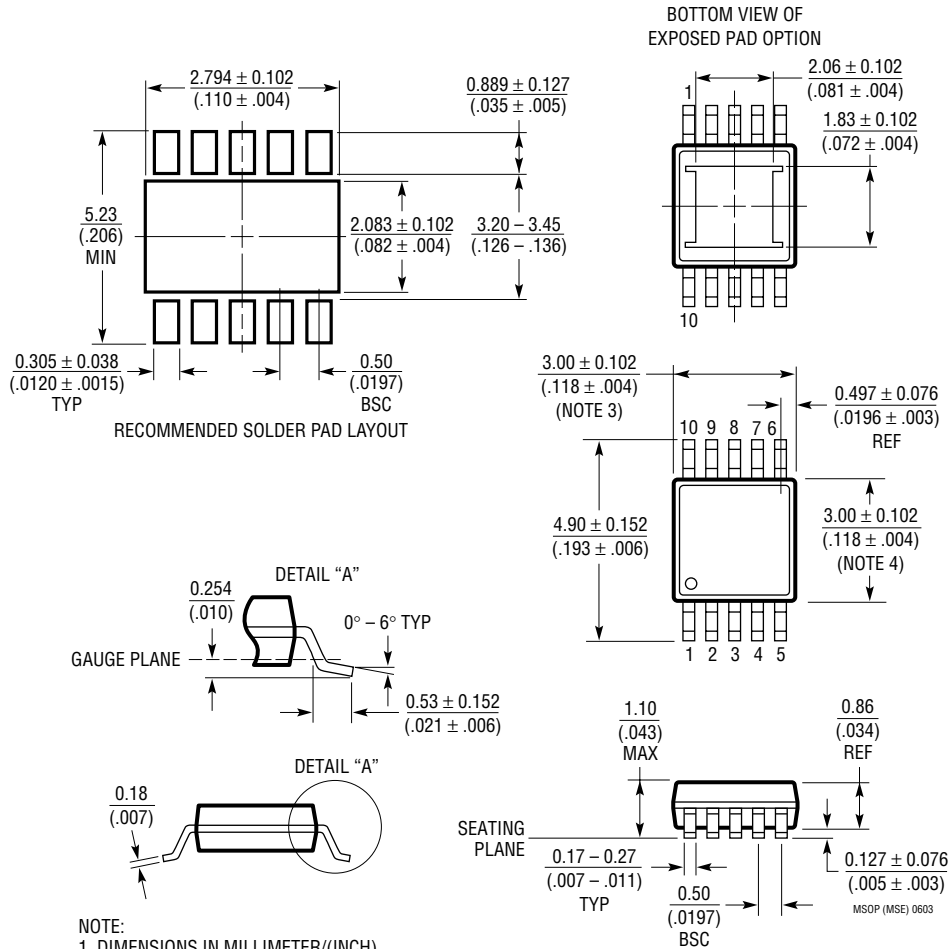

- NOTE:
1. DIMENSIONS IN MILLIMETER/(INCH)
  2. DRAWING NOT TO SCALE
  3. DIMENSION DOES NOT INCLUDE MOLD FLASH, PROTRUSIONS OR GATE BURRS.  
MOLD FLASH, PROTRUSIONS OR GATE BURRS SHALL NOT EXCEED 0.152mm (.006") PER SIDE
  4. DIMENSION DOES NOT INCLUDE INTERLEAD FLASH OR PROTRUSIONS.  
INTERLEAD FLASH OR PROTRUSIONS SHALL NOT EXCEED 0.152mm (.006") PER SIDE
  5. LEAD COPLANARITY (BOTTOM OF LEADS AFTER FORMING) SHALL BE 0.102mm (.004") MAX

## RELATED PARTS

PART NUMBER	DESCRIPTION	COMMENTS
LT1618	Constant-Current/Constant-Voltage DC/DC Converter	Drives 20 White LEDs from Li-Ion, 10-Lead MS Package
LT1932	Constant Current, 1.2MHz, High Efficiency White LED Boost Regulator	$V_{IN}$ : 1V to 10V, $V_{OUT(MAX)} = 34V$ , $I_Q = 1.2mA$ , $I_{SD} < 1\mu A$ , ThinSOT™ Package
LT1942	Quad DC/DC Converter for Triple Output TFT Supply Plus Boost LED Driver, with a 2-Channel Ballaster	TFT Supply: Three Switching Regulators (Two Boost, One Inverting) LED Supply: Up to Two Strings of 10 LEDs. $V_{IN}$ : 2.6V to 16V, $V_{OUT(MAX)} = 45V$ , $I_Q = 7mA$ , $I_{SD} < 1\mu A$ , Low Profile QFN package.
LT3475	36V, 2MHz, Dual 1.5A Step-Down LED Driver	$V_{IN}$ : 4V to 36V, 200kHz to 2MHz, TSSOP20E Package, 3000:1 Dimming
LT3477	3A, 3.5mHz, Constant-Current DC/DC Converter with Dual Rail Sense. Can Drive LEDs in Boost, Buck and Buck-Boost Configurations	$V_{IN}$ : 2.5V to 25V, $V_{OUT(MAX)} = 42V$ , $I_{SD} < 1\mu A$ , QFN/TSSOP Packages
LT3478	4.5A Constant Current BOOST LED Driver with PWM	$V_{IN}$ : 2.7V to 36V, $V_{OUT(MAX)} = 40V$ , $I_{LED(MAX)} = 1.05A$ , $I_{SD} < 5\mu A$ , FE16 Package
LT3479	3A, 3.5MHz, 42V Full Featured Boost/Inverter Converter with Soft-Start	$V_{IN}$ : 2.5V to 24V, $V_{OUT(MAX)} = 40V$ , $I_Q = 5mA$ , $I_{SD} < 1\mu A$ , DFN/TSSOP Packages
LT3474	36V, 2MHz, Step-Down 1A LED Driver	$V_{IN}$ : 4V to 36V, 200kHz to 2MHz, TSSOP16E Package, 400:1 Dimming
LTC3205	Multi-Display LED Controller, Step-Up/Step-Down Fractional Charge Pump, Independent Current and Dimming Control	$V_{IN}$ : 2.8V to 4.5V, 800MHz, QFN Package
LTC3783	PWM LED Power and Boost, Flyback and SEPIC Controller	$V_{IN}$ : 3.6V to 36V, 300kHz, DFN, TSSOP16E Package, 3000:1 Dimming

ThinSOT is a trademark of Linear Technology Corporation.

## Looking for pricing, stock, or lifecycle information?

Click below to explore more details on WIN SOURCE:

 [View LT3003EMSE#PBF on WIN SOURCE](#)

 [Linear Technology](#) Information

## Optimize Your Supply Chain with WIN SOURCE Solutions

-  Global Sourcing Solution
-  Obsolete Management
-  Cost Control Management
-  Shortage Management
-  Alternative Solution
-  Excess Inventory Management