



**THE DATASHEET OF  
LT1510CS#PBF**



# Constant-Voltage/ Constant-Current Battery Charger

## FEATURES

- Charges NiCd, NiMH and Lithium-Ion Batteries — Only One  $1/10$ W Resistor Is Needed to Program Charging Current
- High Efficiency Current Mode PWM with 1.5A Internal Switch and Sense Resistor
- 3% Typical Charging Current Accuracy
- Precision 0.5% Voltage Reference for Voltage Mode Charging or Overvoltage Protection
- Current Sensing Can Be at Either Terminal of the Battery
- Low Reverse Battery Drain Current:  $3\mu\text{A}$
- Charging Current Soft Start
- Shutdown Control
- 500kHz Version Uses Small Inductor

## APPLICATIONS

- Chargers for NiCd, NiMH and Lithium Batteries
- Step-Down Switching Regulator with Precision Adjustable Current Limit

## DESCRIPTION

With switching frequency as high as 500kHz, The LT<sup>®</sup>1510 current mode PWM battery charger is the smallest, sim-

plest, most efficient solution to fast-charge modern rechargeable batteries including lithium-ion (Li-Ion), nickel-metal-hydride (NiMH)\* and nickel-cadmium (NiCd)\* that require constant-current and/or constant-voltage charging. The internal switch is capable of delivering 1.5A DC current (2A peak current). The  $0.1\Omega$  onboard current sense resistor makes the charging current programming very simple. One resistor (or a programming current from a DAC) is required to set the full charging current (1.5A) to within 5% accuracy. The LT1510 with 0.5% reference voltage accuracy meets the critical constant-voltage charging requirement for lithium cells.

The LT1510 can charge batteries ranging from 2V to 20V. Ground sensing of current is not required and the battery's negative terminal can be tied directly to ground. A saturating switch running at 200kHz (500kHz for LT1510-5) gives high charging efficiency and small inductor size. A blocking diode is not required between the chip and the battery because the chip goes into sleep mode and drains only  $3\mu\text{A}$  when the wall adaptor is unplugged. Soft start and shutdown features are also provided. The LT1510 is available in a 16-pin fused lead power SO package with a thermal resistance of  $50^\circ\text{C/W}$ , an 8-pin SO and a 16-pin PDIP.

LT, LTC and LT are registered trademarks of Linear Technology Corporation.

\* NiCd and NiMH batteries require charge termination circuitry (not shown in Figure 1).

## TYPICAL APPLICATIONS

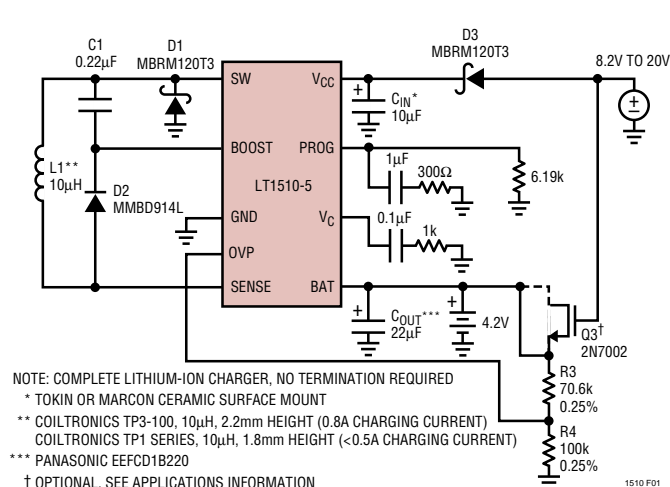

Figure 1. 500kHz Smallest Li-Ion Cell Phone Charger (0.8A)

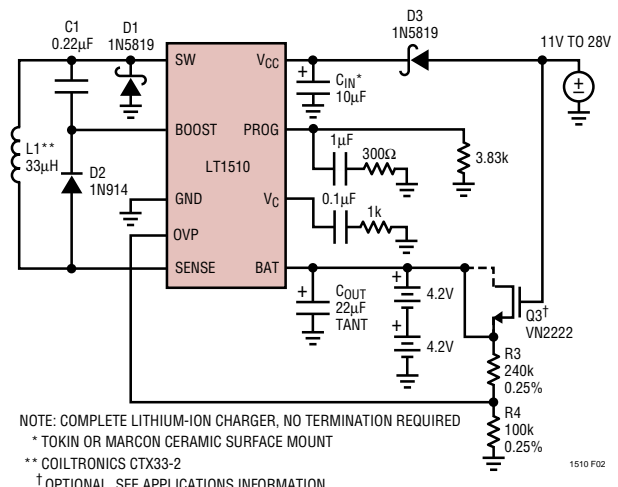

Figure 2. Charging Lithium Batteries (Efficiency at 1.3A > 87%)

# LT1510/LT1510-5

## ABSOLUTE MAXIMUM RATINGS

Supply Voltage ( $V_{MAX}$ )	30V	Operating Ambient Temperature Range	
Switch Voltage with Respect to GND	-3V	Commercial	0°C to 70°C
Boost Pin Voltage with Respect to $V_{CC}$	30V	Extended Commercial (Note 7)	-40°C to 85°C
Boost Pin Voltage with Respect to GND	-5V	Industrial (Note 8)	-40°C to 85°C
$V_C$ , PROG, OVP Pin Voltage	8V	Operating Junction Temperature Range	
$I_{BAT}$ (Average)	1.5A	LT1510C (Note 7)	-40°C to 125°C
Switch Current (Peak)	2A	LT1510I	-40°C to 125°C
Storage Temperature Range	-65°C to 150°C	Lead Temperature (Soldering, 10 sec)	300°C

## PACKAGE/ORDER INFORMATION

<p>TOP VIEW</p> <p>S8 PACKAGE 8-LEAD PLASTIC SO</p> <p><math>T_{JMAX} = 125^{\circ}\text{C}</math>, <math>\theta_{JA} = 125^{\circ}\text{C/W}</math></p>	<p>TOP VIEW</p> <p>GN PACKAGE (0.015 IN) 16-LEAD PLASTIC SSOP</p> <p><math>T_{JMAX} = 125^{\circ}\text{C}</math>, <math>\theta_{JA} = 75^{\circ}\text{C/W}</math></p> <p>** FOUR CORNER PINS ARE FUSED TO INTERNAL DIE ATTACH PADDLE FOR HEAT SINKING. CONNECT THESE FOUR PINS TO EXPANDED PC LANDS FOR PROPER HEAT SINKING.</p>	<p>ORDER PART NUMBER</p> <p>LT1510CGN LT1510IGN LT1510-5CGN LT1510-5IGN</p>	<p>TOP VIEW</p> <p>N PACKAGE 16-LEAD PDIP</p> <p>S PACKAGE* 16-LEAD PLASTIC SO</p> <p><math>T_{JMAX} = 125^{\circ}\text{C}</math>, <math>\theta_{JA} = 75^{\circ}\text{C/W}</math> (N) <math>T_{JMAX} = 125^{\circ}\text{C}</math>, <math>\theta_{JA} = 50^{\circ}\text{C/W}</math> (S)*</p> <p>* <math>V_{CC1}</math> AND <math>V_{CC2}</math> SHOULD BE CONNECTED TOGETHER CLOSE TO THE PINS. ** FOUR CORNER PINS ARE FUSED TO INTERNAL DIE ATTACH PADDLE FOR HEAT SINKING. CONNECT THESE FOUR PINS TO EXPANDED PC LANDS FOR PROPER HEAT SINKING.</p>	<p>ORDER PART NUMBER</p> <p>LT1510CN LT1510CS LT1510IN LT1510IS</p>
<p>ORDER PART NUMBER</p>		<p>GN PART MARKING</p>		
<p>LT1510CS8 LT1510IS8</p>		<p>1510 1510I 15105 15105I</p>		
<p>S8 PART MARKING</p>				
<p>1510 1510I</p>				

Consult factory for Military grade parts.

## ELECTRICAL CHARACTERISTICS

$V_{CC} = 16\text{V}$ ,  $V_{BAT} = 8\text{V}$ ,  $V_{MAX}$  (maximum operating  $V_{CC}$ ) = 28V, no load on any outputs, unless otherwise noted. (Notes 7, 8)

PARAMETER	CONDITIONS	MIN	TYP	MAX	UNITS
<b>Overall</b>					
Supply Current	$V_{PROG} = 2.7\text{V}$ , $V_{CC} \leq 20\text{V}$	●	2.90	4.3	mA
	$V_{PROG} = 2.7\text{V}$ , $20\text{V} < V_{CC} \leq V_{MAX}$	●	2.91	4.5	mA
DC Battery Current, $I_{BAT}$ (Note 1)	$8\text{V} \leq V_{CC} \leq 25\text{V}$ , $0\text{V} \leq V_{BAT} \leq 20\text{V}$ , $T_J < 0^{\circ}\text{C}$	●	0.91	1.09	A
		●	0.93	1.0	A
		●	1.35	1.5	A
		●	75	100	mA
		●	70	130	mA
	$V_{CC} = 28\text{V}$ , $V_{BAT} = 20\text{V}$	●	0.93	1.0	1.07
	●	75	100	125	mA

## ELECTRICAL CHARACTERISTICS

$V_{CC} = 16V$ ,  $V_{BAT} = 8V$ ,  $V_{MAX}$  (maximum operating  $V_{CC}$ ) = 28V, no load on any outputs, unless otherwise noted.

PARAMETER	CONDITIONS		MIN	TYP	MAX	UNITS
<b>Overall</b>						
Minimum Input Operating Voltage	Undervoltage Lockout	●	6.2	7	7.8	V
Reverse Current from Battery (When $V_{CC}$ Is Not Connected, $V_{SW}$ Is Floating)	$V_{BAT} \leq 20V$ , $0^\circ C \leq T_J \leq 70^\circ C$	●		3	15	$\mu A$
Boost Pin Current	$V_{CC} - V_{BOOST} \leq 20V$	●		0.10	20	$\mu A$
	$20V < V_{CC} - V_{BOOST} \leq 28V$	●		0.25	30	$\mu A$
	$2V \leq V_{BOOST} - V_{CC} \leq 8V$ (Switch ON)	●		6	11	mA
	$8V < V_{BOOST} - V_{CC} \leq 25V$ (Switch ON)	●		8	14	mA
<b>Switch</b>						
Switch ON Resistance	$V_{CC} = 10V$					
	$I_{SW} = 1.5A$ , $V_{BOOST} - V_{SW} \geq 2V$ (Note 4) $I_{SW} = 1A$ , $V_{BOOST} - V_{SW} < 2V$ (Unboosted)	● ●		0.3	0.5 2.0	$\Omega$ $\Omega$
$\Delta I_{BOOST}/\Delta I_{SW}$ During Switch ON	$V_{BOOST} = 24V$ , $I_{SW} \leq 1A$			20	35	mA/A
Switch OFF Leakage Current	$V_{SW} = 0V$ , $V_{CC} \leq 20V$	●		2	100	$\mu A$
	$20V < V_{CC} \leq 28V$	●		4	200	$\mu A$
Maximum $V_{BAT}$ with Switch ON		●			$V_{CC} - 2$	V
Minimum $I_{PROG}$ for Switch ON			2	4	20	$\mu A$
Minimum $I_{PROG}$ for Switch OFF at $V_{PROG} \leq 1V$		●	1	2.4		mA
<b>Current Sense Amplifier Inputs (SENSE, BAT)</b>						
Sense Resistance ( $R_{S1}$ )				0.08	0.12	$\Omega$
Total Resistance from SENSE to BAT (Note 3)				0.2	0.25	$\Omega$
BAT Bias Current (Note 5)	$V_C < 0.3V$			-200	-375	$\mu A$
	$V_C > 0.6V$			700	1300	$\mu A$
Input Common Mode Limit (Low)		●	-0.25			V
Input Common Mode Limit (High)		●			$V_{CC} - 2$	V
<b>Reference</b>						
Reference Voltage (Note 1) S8 Package	$R_{PROG} = 4.93k$ , Measured at PROG Pin	●	2.415	2.465	2.515	V
Reference Voltage (Note 2) 16-Pin	$R_{PROG} = 3.28k$ , Measured at OVP with VA Supplying $I_{PROG}$ and Switch OFF		2.453	2.465	2.477	V
Reference Voltage Tolerance, 16-Pin Only	$8V \leq V_{CC} \leq 28V$ , $0^\circ C \leq T_J \leq 70^\circ C$	●	2.446	2.465	2.480	V
	$8V \leq V_{CC} \leq 28V$ , $0^\circ C \leq T_J \leq 125^\circ C$	●	2.441		2.489	V
	$8V \leq V_{CC} \leq 28V$ , $T_J < 0^\circ C$	●	2.430		2.489	V
<b>Oscillator</b>						
Switching Frequency	LT1510		180	200	220	kHz
	LT1510-5		440	500	550	kHz
Switching Frequency Tolerance	All Conditions of $V_{CC}$ , Temperature, LT1510	●	170	200	230	kHz
	LT1510, $T_J < 0^\circ C$	●	160		230	kHz
	LT1510-5	●	425	500	575	kHz
	LT1510-5, $T_J < 0^\circ C$	●	400		575	kHz
Maximum Duty Cycle	LT1510	●	87			%
	LT1510, $T_A = 25^\circ C$ (Note 8)	●	90	93		%
	LT1510-5 (Note 9)	●	77	81		%

## ELECTRICAL CHARACTERISTICS

$V_{CC} = 16V$ ,  $V_{BAT} = 8V$ ,  $V_{MAX}$  (maximum operating  $V_{CC}$ ) = 28V, no load on any outputs, unless otherwise noted.

PARAMETER	CONDITIONS	MIN	TYP	MAX	UNITS	
<b>Current Amplifier (CA2)</b>						
Transconductance	$V_C = 1V$ , $I_{VC} = \pm 1\mu A$	150	250	550	$\mu mho$	
Maximum $V_C$ for Switch OFF		●		0.6	V	
$I_{VC}$ Current (Out of Pin)	$V_C \geq 0.6V$ $V_C < 0.45V$			100 3	$\mu A$ mA	
<b>Voltage Amplifier (VA), 16-Pin Only</b>						
Transconductance (Note 2)	Output Current from 100 $\mu A$ to 500 $\mu A$		0.5	1.2	2.5	mho
Output Source Current, $V_{CC} = 10V$	$V_{PROG} = V_{OVP} = V_{REF} + 10mV$		1.3			mA
OVP Input Bias Current	At 0.75mA VA Output Current	●		50	150	nA

The ● denotes specifications which apply over the specified temperature range.

**Note 1:** Tested with Test Circuit 1.

**Note 2:** Tested with Test Circuit 2.

**Note 3:** Sense resistor  $R_{S1}$  and package bond wires.

**Note 4:** Applies to 16-pin only. 8-pin packages are guaranteed but not tested at  $-40^\circ C$ .

**Note 5:** Current ( $\approx 700\mu A$ ) flows into the pins during normal operation and also when an external shutdown signal on the  $V_C$  pin is greater than 0.3V. Current decreases to  $\approx 200\mu A$  and flows out of the pins when external shutdown holds the  $V_C$  pin below 0.3V. Current drops to near zero when input voltage collapses. See external Shutdown in Applications Information section.

**Note 6:** A linear interpolation can be used for reference voltage specification between  $0^\circ C$  and  $-40^\circ C$ .

**Note 7:** Commercial grade device specifications are guaranteed over the  $0^\circ C$  to  $70^\circ C$  temperature range. In addition, commercial grade device specifications are assured over the  $-40^\circ C$  to  $85^\circ C$  temperature range by design or correlation, but are not production tested.

Maximum allowable ambient temperature may be limited by power dissipation. Parts may not necessarily be operated simultaneously at maximum power dissipation and maximum ambient temperature. Temperature rise calculations must be done as shown in the Applications Information section to ensure that maximum junction temperature does not exceed the  $125^\circ C$  limit. With high power dissipation, maximum ambient temperature may be less than  $70^\circ C$ .

**Note 8:** Industrial grade device specifications are guaranteed over the  $-40^\circ C$  to  $85^\circ C$  temperature range.

**Note 9:** 91% maximum duty cycle is guaranteed by design if  $V_{BAT}$  or  $V_X$  (see Figure 8 in Application Information) is kept between 3V and 5V.

**Note 10:**  $V_{BAT} = 4.2V$ .

## TYPICAL PERFORMANCE CHARACTERISTICS

Thermally Limited Maximum Charging Current, 8-Pin SO

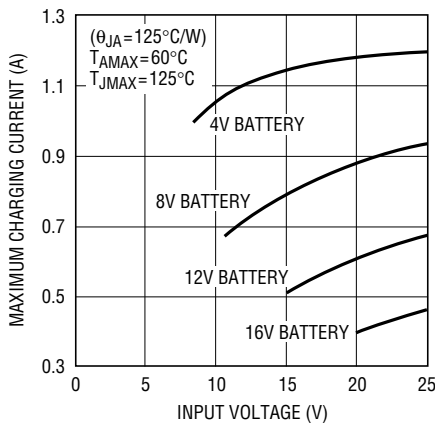

1510 G12

Thermally Limited Maximum Charging Current, 16-Pin SO

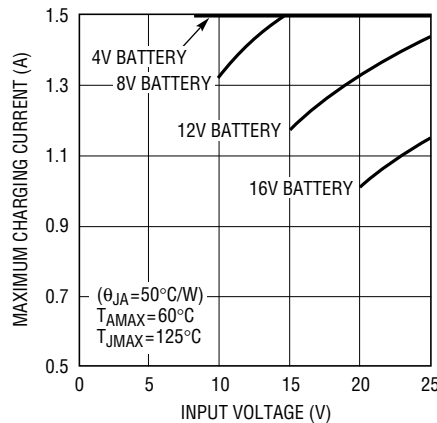

1510 G13

Thermally Limited Maximum Charging Current, 16-Pin GN

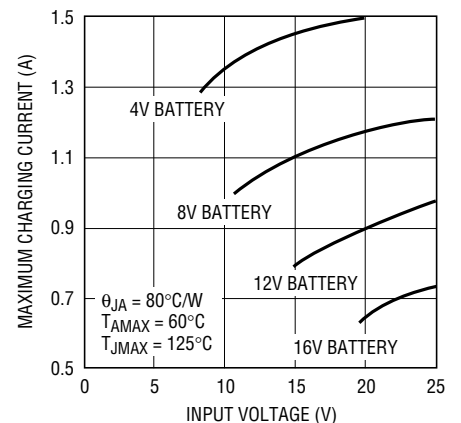

LT1510 • TPC14

# TYPICAL PERFORMANCE CHARACTERISTICS

**Efficiency of Figure 2 Circuit**

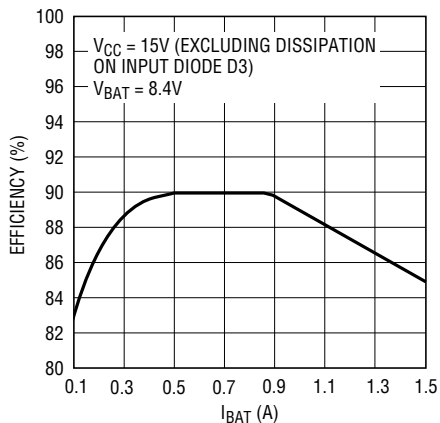

1510 G01

**ICC vs Duty Cycle**

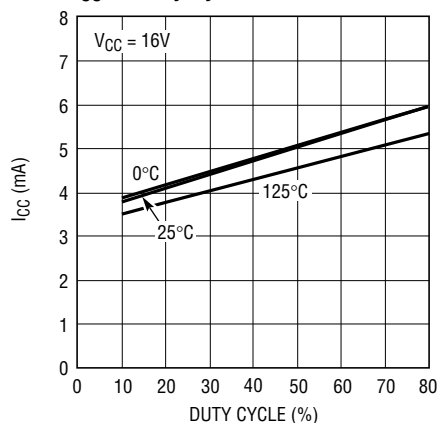

1510 G04

**Switching Frequency vs Temperature**

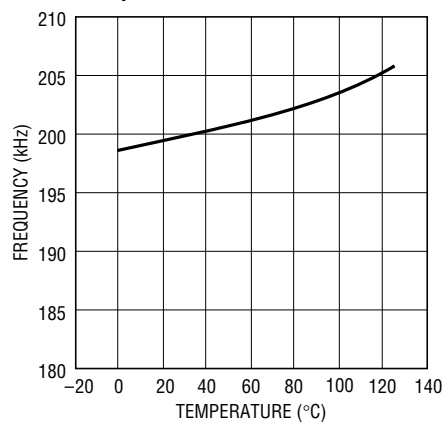

1510 G05

**ICC vs VCC**

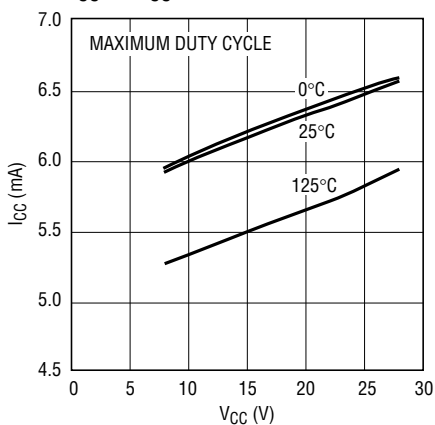

1510 G03

**VREF Line Regulation**

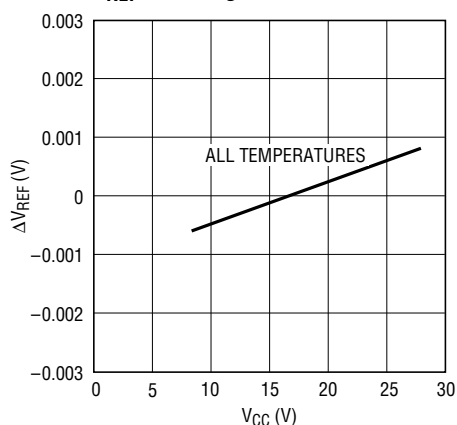

1510 G02

**I<sub>VA</sub> vs ΔV<sub>OVP</sub> (Voltage Amplifier)**

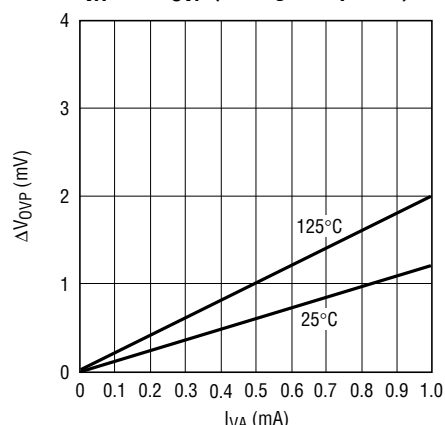

1510 G08

**Maximum Duty Cycle**

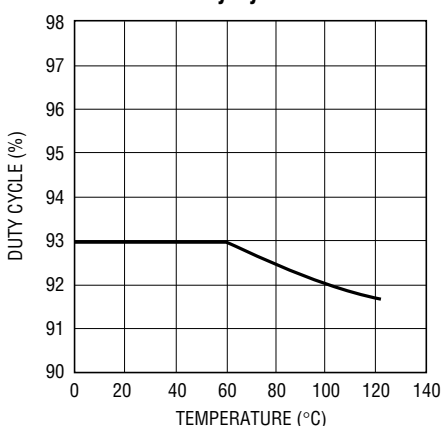

1510 G09

**V<sub>C</sub> Pin Characteristic**

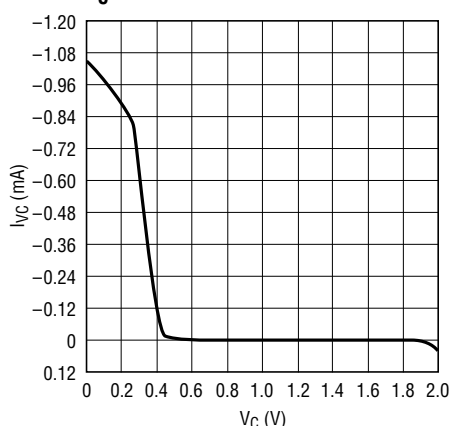

1510 G10

**PROG Pin Characteristic**

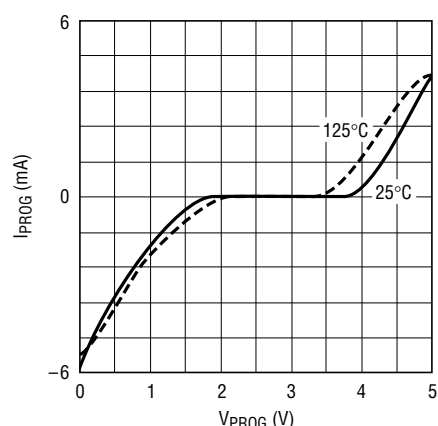

1510 G11

## TYPICAL PERFORMANCE CHARACTERISTICS

Switch Current vs Boost Current vs Boost Voltage

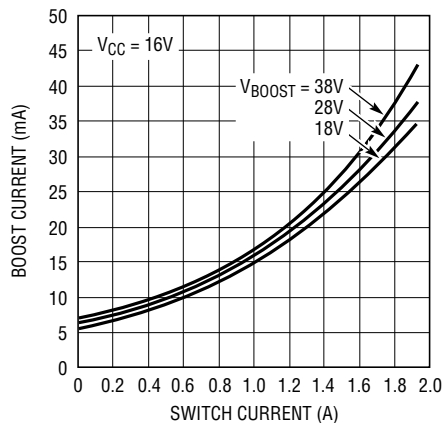

1510 G07

Reference Voltage vs Temperature

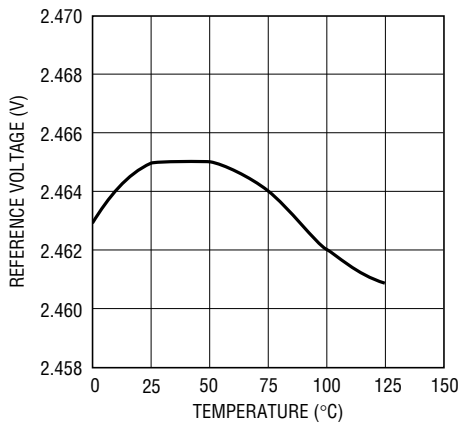

1510 G14

VBOOST vs Maximum Duty Cycle

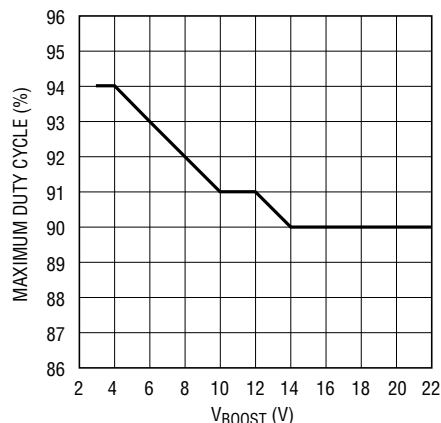

LT1510 • TPC15

## PIN FUNCTIONS

**GND:** Ground Pin.

**SW:** Switch Output. The Schottky catch diode must be placed with very short lead length in close proximity to SW pin and GND.

**VCC:** Supply for the Chip. For good bypass, a low ESR capacitor of 10 $\mu$ F or higher is required, with the lead length kept to a minimum. VCC should be between 8V and 28V and at least 2V higher than VBAT for VBAT less than 10V, and 2.5V higher than VBAT for VBAT greater than 10V. Under-voltage lockout starts and switching stops when VCC goes below 7V. Note that there is a parasitic diode inside from SW pin to VCC pin. Do not force VCC below SW by more than 0.7V with battery present. All VCC pins should be shorted together close to the pins.

**BOOST:** This pin is used to bootstrap and drive the switch power NPN transistor to a low on-voltage for low power dissipation. In normal operation, VBOOST = VCC + VBAT when switch is on. Maximum allowable VBOOST is 55V.

**SENSE:** Current Amplifier CA1 Input. Sensing can be at either terminal of the battery. Note that current sense resistor RS1 (0.08 $\Omega$ ) is between Sense and BAT pins.

**BAT:** Current Amplifier CA1 Input.

**PROG:** This pin is for programming the charging current and for system loop compensation. During normal operation, VPROG stays close to 2.465V. If it is shorted to GND the switching will stop. When a microprocessor-controlled DAC is used to program charging current, it must be capable of sinking current at a compliance up to 2.465V.

**VC:** This is the control signal of the inner loop of the current mode PWM. Switching starts at 0.7V and higher VC corresponds to higher charging current in normal operation. A capacitor of at least 0.1 $\mu$ F to GND filters out noise and controls the rate of soft start. To shut down switching, pull this pin low. Typical output current is 30 $\mu$ A.

**OVP:** This is the input to the amplifier VA with a threshold of 2.465V. Typical input current is about 50nA into pin. For charging lithium-ion batteries, VA monitors the battery voltage and reduces charging current when battery voltage reaches the preset value. If it is not used, the OVP pin should be grounded.

# BLOCK DIAGRAM

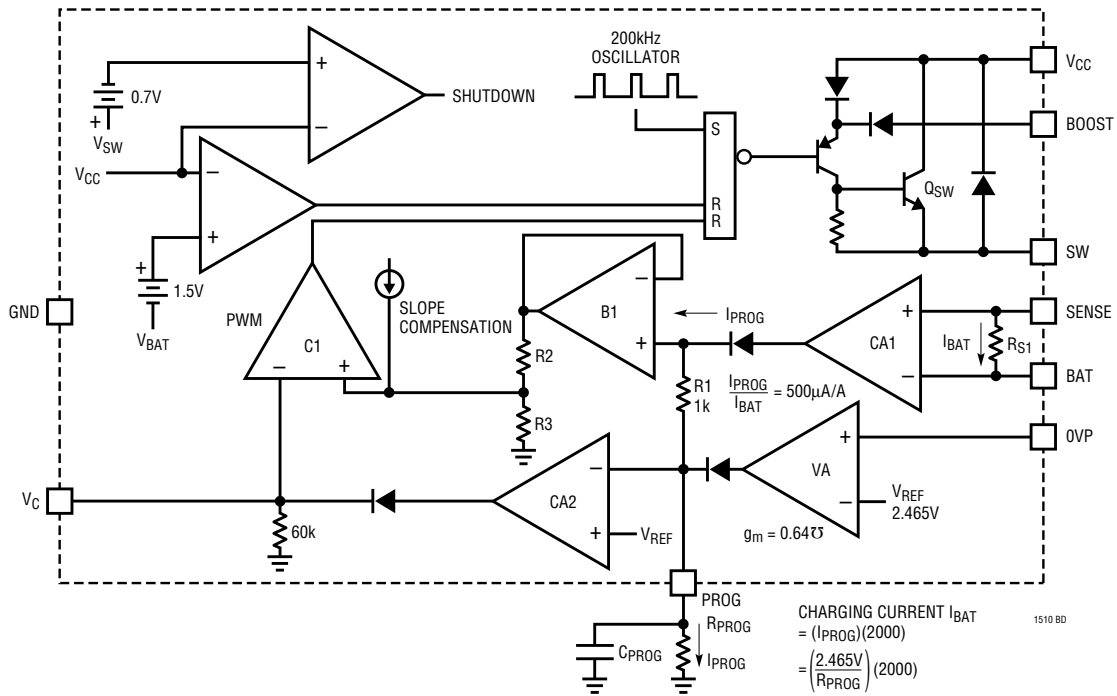

# TEST CIRCUITS

Test Circuit 1

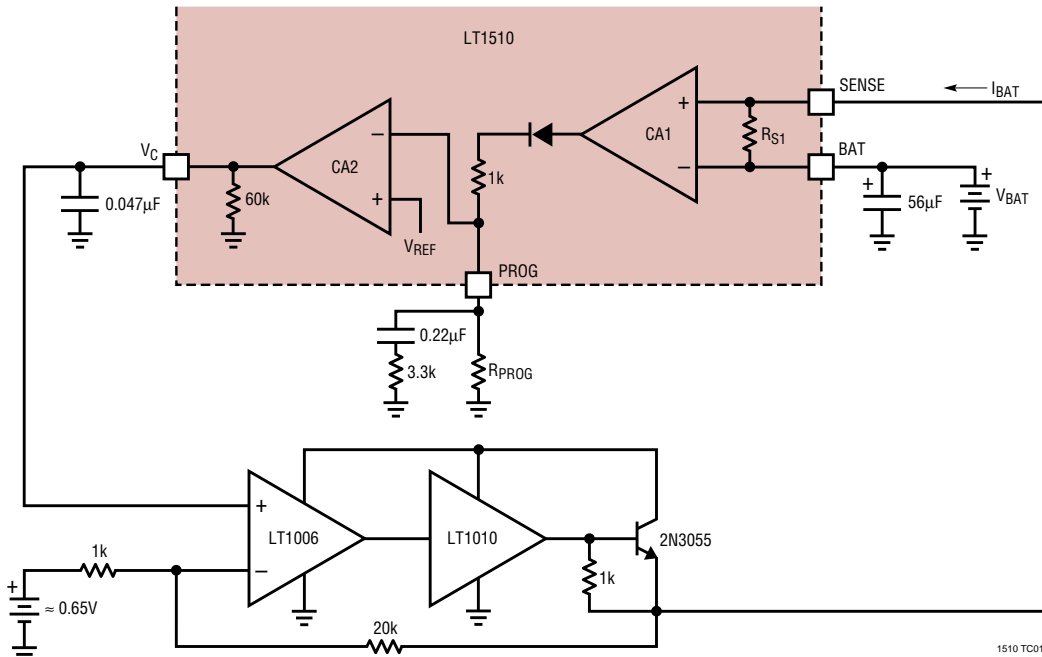

## TEST CIRCUITS

Test Circuit 2

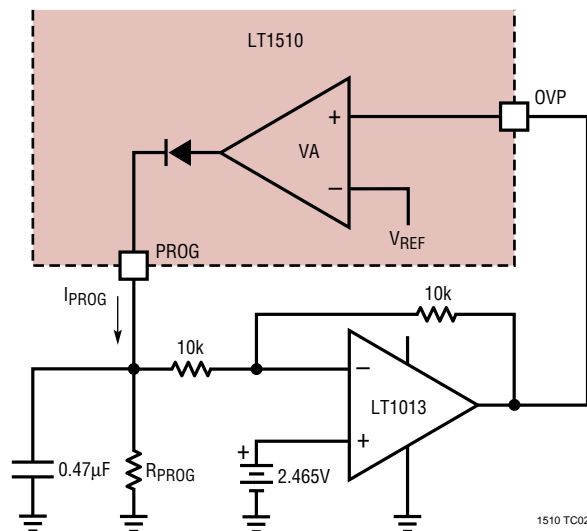

## OPERATION

The LT1510 is a current mode PWM step-down (buck) switcher. The battery DC charging current is programmed by a resistor  $R_{PROG}$  (or a DAC output current) at the PROG pin (see Block Diagram). Amplifier CA1 converts the charging current through  $R_{S1}$  to a much lower current  $I_{PROG}$  ( $500\mu A/A$ ) fed into the PROG pin. Amplifier CA2 compares the output of CA1 with the programmed current and drives the PWM loop to force them to be equal. High DC accuracy is achieved with averaging capacitor  $C_{PROG}$ . Note that  $I_{PROG}$  has both AC and DC components.  $I_{PROG}$  goes through  $R1$  and generates a ramp signal that is fed to the PWM control comparator C1 through buffer B1 and

level shift resistors R2 and R3, forming the current mode inner loop. The Boost pin drives the switch NPN  $Q_{SW}$  into saturation and reduces power loss. For batteries like lithium-ion that require both constant-current and constant-voltage charging, the 0.5%, 2.465V reference and the amplifier VA reduce the charging current when battery voltage reaches the preset level. For NiMH and NiCd, VA can be used for overvoltage protection. When input voltage is not present, the charger goes into low current ( $3\mu A$  typically) sleep mode as input drops down to 0.7V below battery voltage. To shut down the charger, simply pull the  $V_C$  pin low with a transistor.

## APPLICATIONS INFORMATION

Application Note 68, the LT1510 design manual, contains more in depth applications examples.

### Input and Output Capacitors

In the chargers in Figures 1 and 2 on the first page of this data sheet, the input capacitor  $C_{IN}$  is assumed to absorb all input switching ripple current in the converter, so it must have adequate ripple current rating. Worst-case RMS ripple current will be equal to one half of output charging current. Actual capacitance value is not critical. Solid

tantalum capacitors such as the AVX TPS and Sprague 593D series have high ripple current rating in a relatively small surface mount package, but *caution must be used when tantalum capacitors are used for input bypass*. High input surge currents can be created when the adapter is hot-plugged to the charger and solid tantalum capacitors have a known failure mechanism when subjected to very high turn-on surge currents. Highest possible voltage rating on the capacitor will minimize problems. Consult with the manufacturer before use. Alternatives include new high

## APPLICATIONS INFORMATION

capacity ceramic capacitor (5μF to 10μF) from Tokin or United Chemi-Con/MARCON, et al., and the old standby, aluminum electrolytic, which will require more microfarads to achieve adequate ripple rating. OS-CON can also be used.

The output capacitor C<sub>OUT</sub> is also assumed to absorb output switching current ripple. The general formula for capacitor current is:

$$I_{RMS} = \frac{0.29(V_{BAT}) \left(1 - \frac{V_{BAT}}{V_{CC}}\right)}{(L1)(f)}$$

For example, with V<sub>CC</sub> = 16V, V<sub>BAT</sub> = 8.4V, L1 = 30μH and f = 200kHz, I<sub>RMS</sub> = 0.2A.

EMI considerations usually make it desirable to minimize ripple current in the battery leads, and beads or inductors may be added to increase battery impedance at the 200kHz switching frequency. Switching ripple current splits between the battery and the output capacitor depending on the ESR of the output capacitor and the battery impedance. If the ESR of C<sub>OUT</sub> is 0.2Ω and the battery impedance is raised to 4Ω with a bead of inductor, only 5% of the current ripple will flow in the battery.

### Soft Start

The LT1510 is soft started by the 0.1μF capacitor on V<sub>C</sub> pin. On start-up, V<sub>C</sub> pin voltage will rise quickly to 0.5V, then ramp at a rate set by the internal 45μA pull-up current and the external capacitor. Battery charging current starts ramping up when V<sub>C</sub> voltage reaches 0.7V and full current is achieved with V<sub>C</sub> at 1.1V. With a 0.1μF capacitor, time to reach full charge current is about 3ms and it is assumed that input voltage to the charger will reach full value in less than 3ms. Capacitance can be increased up to 0.47μF if longer input start-up times are needed.

In any switching regulator, conventional timer-based soft starting can be defeated if the input voltage rises much slower than the time-out period. This happens because the switching regulators in the battery charger and the computer power supply are typically supplying a fixed amount of power to the load. If input voltage comes up slowly compared to the soft start time, the regulators will try to

deliver full power to the load when the input voltage is still well below its final value. If the adapter is current limited, it cannot deliver full power at reduced output voltages and the possibility exists for a quasi “latch” state where the adapter output stays in a current limited state at reduced output voltage. For instance, if maximum charger plus computer load power is 20W, a 24V adapter might be current limited at 1A. If adapter voltage is less than (20W/1A = 20V) when full power is drawn, the adapter voltage will be sucked down by the constant 20W load until it reaches a lower stable state where the switching regulators can no longer supply full load. This situation can be prevented by utilizing *undervoltage lockout*, set higher than the minimum adapter voltage where full power can be achieved.

A fixed undervoltage lockout of 7V is built into the V<sub>CC</sub> pin. Internal lockout is performed by clamping the V<sub>C</sub> pin low. The V<sub>C</sub> pin is released from its clamped state when the V<sub>CC</sub> pin rises above 7V. The charger will start delivering current about 2ms after V<sub>C</sub> is released, as set by the 0.1μF at V<sub>C</sub> pin. Higher lockout voltage can be implemented with a Zener diode (see Figure 3 circuit).

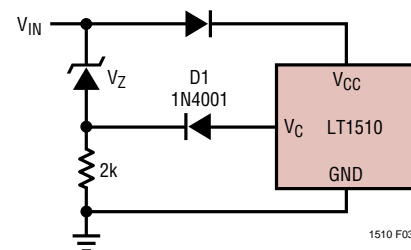

Figure 3. Undervoltage Lockout

The lockout voltage will be V<sub>IN</sub> = V<sub>Z</sub> + 1V.

For example, for a 24V adapter to start charging at 22V<sub>IN</sub>, choose V<sub>Z</sub> = 21V. When V<sub>IN</sub> is less than 22V, D1 keeps V<sub>C</sub> low and charger off.

### Charging Current Programming

The basic formula for charging current is (see Block Diagram):

$$I_{BAT} = (I_{PROG})(2000) = \left(\frac{2.465V}{R_{PROG}}\right)(2000)$$

## APPLICATIONS INFORMATION

where  $R_{PROG}$  is the total resistance from PROG pin to ground.

For example, 1A charging current is needed.

$$R_{PROG} = \frac{(2.465V)(2000)}{1A} = 4.93k$$

Charging current can also be programmed by pulse width modulating  $I_{PROG}$  with a switch Q1 to  $R_{PROG}$  at a frequency higher than a few kHz (Figure 4). Charging current will be proportional to the duty cycle of the switch with full current at 100% duty cycle.

When a microprocessor DAC output is used to control charging current, it must be capable of sinking current at a compliance up to 2.5V if connected directly to the PROG pin.

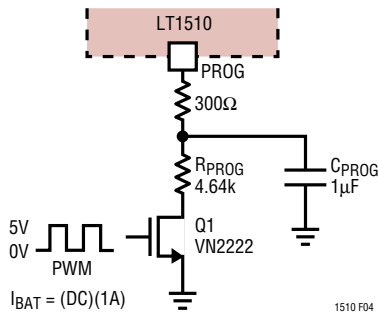

Figure 4. PWM Current Programming

### Lithium-Ion Charging

The circuit in Figure 2 uses the 16-pin LT1510 to charge lithium-ion batteries at a constant 1.3A until battery voltage reaches a limit set by R3 and R4. The charger will then automatically go into a constant-voltage mode with current decreasing to zero over time as the battery reaches full charge. This is the normal regimen for lithium-ion charging, with the charger holding the battery at “float” voltage indefinitely. In this case no external sensing of full charge is needed.

Current through the R3/R4 divider is set at a compromise value of 25μA to minimize battery drain when the charger is off and to avoid large errors due to the 50nA bias current of the OVP pin. Q3 can be added if it is desired to eliminate

even this low current drain. A 47k resistor from adapter output to ground should be added if Q3 is used to ensure that the gate is pulled to ground.

With divider current set at 25μA,  $R4 = 2.465/25\mu A = 100k$  and,

$$R3 = \frac{(R4)(V_{BAT} - 2.465)}{2.465 + R4(0.05\mu A)} = \frac{100k(8.4 - 2.465)}{2.465 + 100k(0.05\mu A)} = 240k$$

Lithium-ion batteries typically require float voltage accuracy of 1% to 2%. Accuracy of the LT1510 OVP voltage is  $\pm 0.5\%$  at 25°C and  $\pm 1\%$  over full temperature. This leads to the possibility that very accurate (0.1%) resistors might be needed for R3 and R4. Actually, the temperature of the LT1510 will rarely exceed 50°C in float mode because charging currents have tapered off to a low level, so 0.25% resistors will normally provide the required level of overall accuracy.

### External Shutdown

The LT1510 can be externally shut down by pulling the  $V_C$  pin low with an open drain MOSFET, such as VN2222. The  $V_C$  pin should be pulled below 0.8V at room temperature to ensure shutdown. This threshold decreases at about 2mV/°C. A diode connected between the MOSFET drain and the  $V_C$  pin will still ensure the shutdown state over all temperatures, but it results in slightly different conditions as outlined below.

If the  $V_C$  pin is held below threshold, but above  $\approx 0.4V$ , the current flowing *into* the BAT pin will remain at about 700μA. Pulling the  $V_C$  pin below 0.4V will cause the current to drop to  $\approx 200\mu A$  and reverse, flowing *out* of the BAT pin. Although these currents are low, the long term effect may need to be considered if the charger is held in a shutdown state for very long periods of time, with the charger input voltage remaining. Removing the charger input voltage causes all currents to drop to near zero.

If it is acceptable to have 200μA flowing into the battery while the charger is in shutdown, simply pull the  $V_C$  pin directly to ground with the external MOSFET. The resistor divider used to sense battery voltage will pull current out

## APPLICATIONS INFORMATION

of the battery, canceling part or all of the 200µA. Note that if net current is into the battery and the battery is removed, the charger output voltage will float high, to near input voltage. This could be a problem when reinserting the battery, if the resulting output capacitor/battery surge current is high enough to damage either the battery or the capacitor.

If net current into the battery must be less than zero in shutdown, there are several options. Increasing divider current to 300µA - 400µA will ensure that net battery current is less than zero. For long term storage conditions however, the divider may need to be disconnected with a MOSFET switch as shown in Figures 2 and 5. A second option is to connect a 1N914 diode in series with the MOSFET drain. This will limit how far the V<sub>C</sub> pin will be pulled down, and current (≈ 700µA) will flow *into* the BAT pin, and therefore out of the battery. This is not usually a problem unless the charger will remain in the shutdown state with input power applied for very long periods of time.

Removing input power to the charger will cause the BAT pin current to drop to near zero, with only the divider current remaining as a small drain on the battery. Even that current can be eliminated with a switch as shown in Figures 2 and 5.

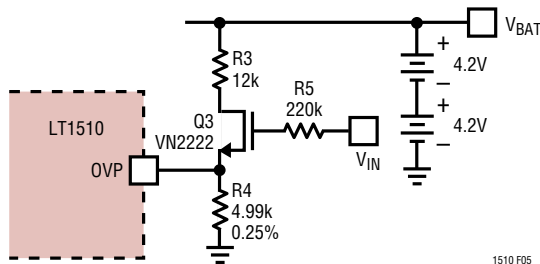

Figure 5. Disconnecting Voltage Divider

Some battery manufacturers recommend termination of constant-voltage float mode after charging current has dropped below a specified level (typically 50mA to 100mA) and a further time-out period of 30 minutes to 90 minutes has elapsed. This may extend the life of the battery, so check with manufacturers for details. The circuit in Figure 7 will detect when charging current has dropped below 75mA. This logic signal is used to initiate a time-out

period, after which the LT1510 can be shut down by pulling the V<sub>C</sub> pin low with an open collector or drain. Some external means must be used to detect the need for additional charging if needed, or the charger may be turned on periodically to complete a short float-voltage cycle.

Current trip level is determined by the battery voltage, R1 through R3, and the internal LT1510 sense resistor (≈ 0.18Ω pin-to-pin). D2 generates hysteresis in the trip level to avoid multiple comparator transitions.

### Nickel-Cadmium and Nickel-Metal-Hydrate Charging

The circuit in Figure 6 uses the 8-pin LT1510 to charge NiCd or NiMH batteries up to 12V with charging currents of 0.5A when Q1 is on and 50mA when Q1 is off.

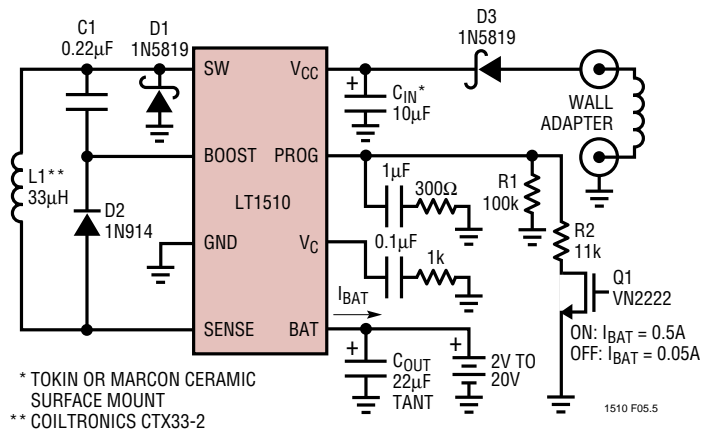

Figure 6. Charging NiMH or NiCd Batteries (Efficiency at 0.5A ≈ 90%)

For a 2-level charger, R1 and R2 are found from:

$$I_{BAT} = \frac{(2000)(2.465)}{R_{PROG}}$$

$$R1 = \frac{(2.465)(2000)}{I_{LOW}} \quad R2 = \frac{(2.465)(2000)}{I_{HI} - I_{LOW}}$$

All battery chargers with fast-charge rates require some means to detect full charge state in the battery to terminate the high charging current. NiCd batteries are typically charged at high current until temperature rise or battery

**APPLICATIONS INFORMATION**

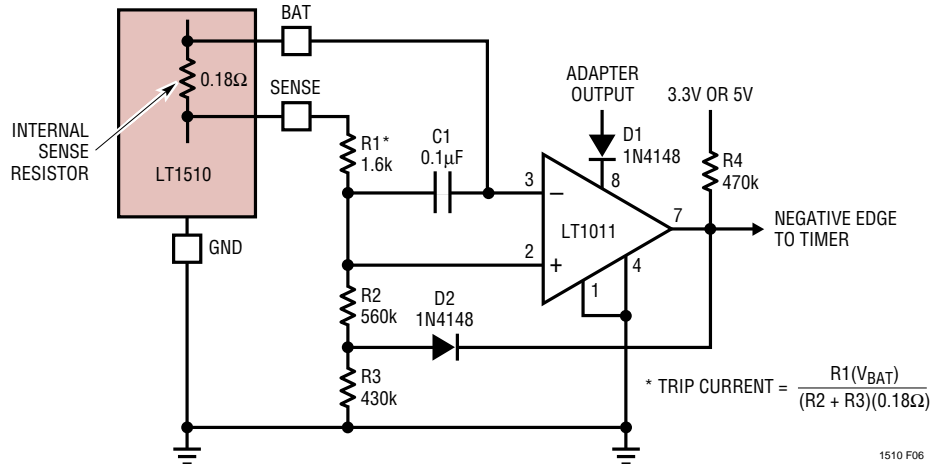

**Figure 7. Current Comparator for Initiating Float Time-Out**

voltage decrease is detected as an indication of near full charge. The charging current is then reduced to a much lower value and maintained as a constant trickle charge. An intermediate “top off” current may be used for a fixed time period to reduce 100% charge time.

NiMH batteries are similar in chemistry to NiCd but have two differences related to charging. First, the inflection characteristic in battery voltage as full charge is approached is not nearly as pronounced. This makes it more difficult to use dV/dt as an indicator of full charge, and change of temperature is more often used with a temperature sensor in the battery pack. Secondly, constant trickle charge may not be recommended. Instead, a moderate level of current is used on a pulse basis (≈ 1% to 5% duty cycle) with the time-averaged value substituting for a constant low trickle.

**Thermal Calculations**

If the LT1510 is used for charging currents above 0.4A, a thermal calculation should be done to ensure that junction temperature will not exceed 125°C. Power dissipation in the IC is caused by bias and driver current, switch resistance, switch transition losses and the current sense resistor. The following equations show that maximum practical charging current for the 8-pin SO package (125° C/W thermal resistance) is about 0.8A for an 8.4V

battery and 1.1A for a 4.2V battery. This assumes a 60°C maximum ambient temperature. The 16-pin SO, with a thermal resistance of 50°C/W, can provide a full 1.5A charging current in many situations. The 16-pin PDIP falls between these extremes. Graphs are shown in the Typical Performance Characteristics section.

$$P_{BIAS} = (3.5mA)(V_{IN}) + 1.5mA(V_{BAT}) + \frac{(V_{BAT})^2}{V_{IN}} [7.5mA + (0.012)(I_{BAT})]$$

$$P_{DRIVER} = \frac{(I_{BAT})(V_{BAT})^2 \left(1 + \frac{V_{BAT}}{30}\right)}{55(V_{IN})}$$

$$P_{SW} = \frac{(I_{BAT})^2 (R_{SW})(V_{BAT})}{V_{IN}} + (t_{OL})(V_{IN})(I_{BAT})(f)$$

$$P_{SENSE} = (0.18\Omega)(I_{BAT})^2$$

R<sub>SW</sub> = Switch ON resistance ≈ 0.35Ω  
 t<sub>OL</sub> = Effective switch overlap time ≈ 10ns  
 f = 200kHz (500kHz for LT1510-5)

## APPLICATIONS INFORMATION

Example:  $V_{IN} = 15V$ ,  $V_{BAT} = 8.4V$ ,  $I_{BAT} = 1.2A$ ;

$$P_{BIAS} = (3.5mA)(15) + 1.5mA(8.4) + \frac{(8.4)^2}{15} [7.5mA + (0.012)(1.2)] = 0.17W$$

$$P_{DRIVER} = \frac{(1.2)(8.4)^2 \left(1 + \frac{8.4}{30}\right)}{55(15)} = 0.13W$$

$$P_{SW} = \frac{(1.2)^2(0.35)(8.4)}{15} + (10 \cdot 10^{-9})(15)(1.2)(200kHz) = 0.28 + 0.04 = 0.32W$$

$$P_{SENSE} = (0.18)(1.2)^2 = 0.26W$$

Total power in the IC is:

$$0.17 + 0.13 + 0.32 + 0.26 = 0.88W$$

Temperature rise will be  $(0.88W)(50^\circ C/W) = 44^\circ C$ . This assumes that the LT1510 is properly heat sunk by connecting the four fused ground pins to the expanded traces and that the PC board has a backside or internal plane for heat spreading.

The  $P_{DRIVER}$  term can be reduced by connecting the boost diode D2 (see Figures 2 and 6 circuits) to a lower system voltage (lower than  $V_{BAT}$ ) instead of  $V_{BAT}$  (see Figure 8).

Then,

$$P_{DRIVER} = \frac{(I_{BAT})(V_{BAT})(V_X) \left(1 + \frac{V_X}{30}\right)}{55(V_{IN})}$$

For example,  $V_X = 3.3V$ ,

$$P_{DRIVER} = \frac{(1.2A)(8.4V)(3.3V) \left(1 + \frac{3.3V}{30}\right)}{55(15V)} = 0.045W$$

The average  $I_{VX}$  required is:

$$\frac{P_{DRIVER}}{V_X} = \frac{0.045W}{3.3V} = 14mA$$

Total board area becomes an important factor when the area of the board drops below about 20 square inches. The graph in Figure 9 shows thermal resistance vs board area for 2-layer and 4-layer boards. Note that 4-layer boards have significantly lower thermal resistance, but both types show a rapid increase for reduced board areas. Figure 10 shows actual measured lead temperature for chargers operating at full current. Battery voltage and input voltage will affect device power dissipation, so the data sheet power calculations must be used to extrapolate these readings to other situations.

Vias should be used to connect board layers together. Planes under the charger area can be cut away from the rest of the board and connected with vias to form both a

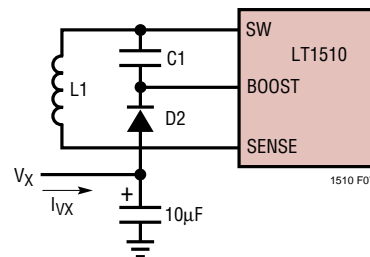

Figure 8

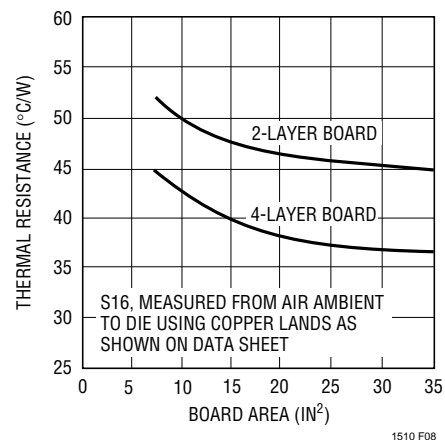
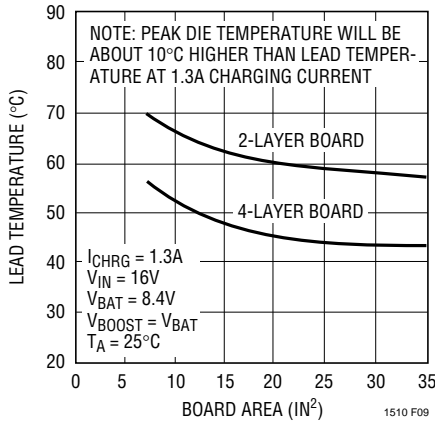

Figure 9. LT1510 Thermal Resistance

**APPLICATIONS INFORMATION**



**Figure 10. LT1510 Lead temperature**

low thermal resistance system and to act as a ground plane for reduced EMI.

**Higher Duty Cycle for the LT1510 Battery Charger**

Maximum duty cycle for the LT1510 is typically 90% but this may be too low for some applications. For example, if an 18V ±3% adapter is used to charge ten NiMH cells, the charger must put out 15V maximum. A total of 1.6V is lost in the input diode, switch resistance, inductor resistance and parasitics so the required duty cycle is 15/16.4 = 91.4%. As it turns out, duty cycle can be extended to 93% by restricting boost voltage to 5V instead of using V<sub>BAT</sub> as is normally done. This lower boost voltage V<sub>X</sub> (see Figure 8) also reduces power dissipation in the LT1510, so it is a win-win decision.

**Even Lower Dropout**

For even lower dropout and/or reducing heat on the board, the input diode D3 (Figures 2 and 6) should be replaced with a FET. It is pretty straightforward to connect a P-channel FET across the input diode and connect its gate to the battery so that the FET commutates off when the input goes low. The problem is that the gate must be pumped low so that the FET is fully turned on even when the input is only a volt or two above the battery voltage. Also there is a turn off speed issue. The FET should turn off instantly when the input is dead shorted to avoid large current surges from the battery back through the charger into the FET. Gate capacitance slows turn off, so a small P-FET (Q2) discharges the gate capacitance quickly in the

event of an input short. The body diode of Q2 creates the necessary pumping action to keep the gate of Q1 low during normal operation (see Figure 11).

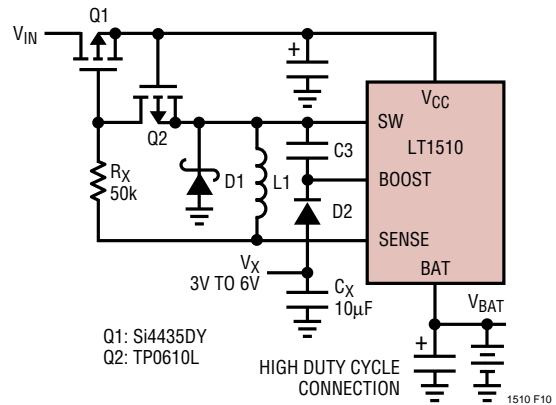

**Figure 11. Replacing the Input Diode**

**Layout Considerations**

Switch rise and fall times are under 10ns for maximum efficiency. To prevent radiation, the catch diode, SW pin and input bypass capacitor leads should be kept as short as possible. A ground plane should be used under the switching circuitry to prevent interplane coupling and to act as a thermal spreading path. All ground pins should be connected to expand traces for low thermal resistance. The fast-switching high current ground path including the switch, catch diode and input capacitor should be kept very short. Catch diode and input capacitor should be close to the chip and terminated to the same point. This path contains nanosecond rise and fall times with several amps of current. The other paths contain only DC and /or 200kHz triwave and are less critical. Figure 13 shows critical path layout. Figure 12 indicates the high speed, high current switching path.

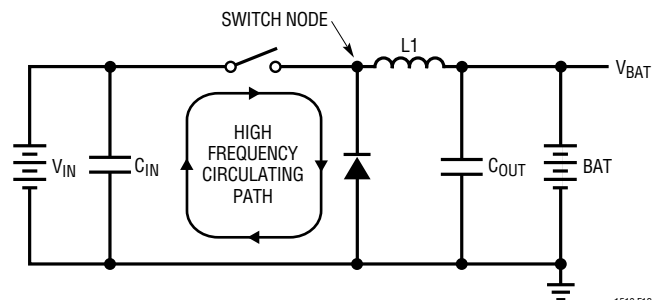

**Figure 12. High Speed Switching Path**

# APPLICATIONS INFORMATION

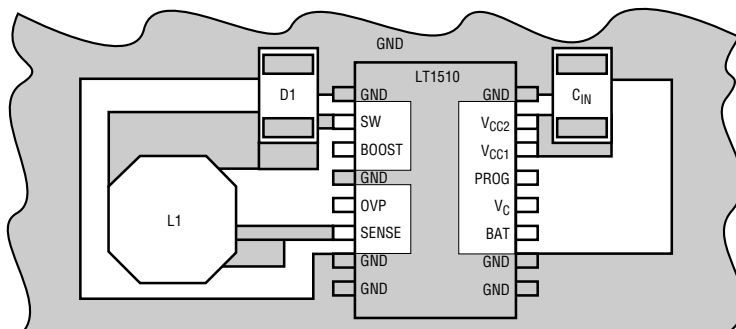
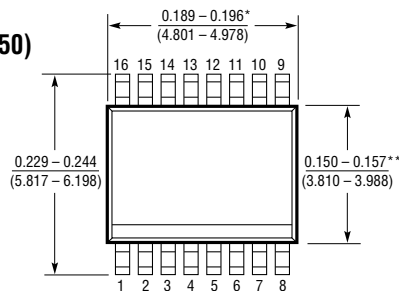
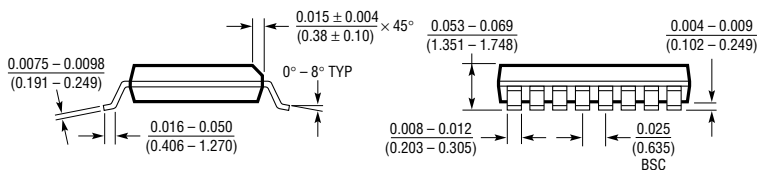

Figure 13. Critical Electrical and Thermal Path Layer

# PACKAGE DESCRIPTION

Dimensions in inches (millimeters) unless otherwise noted.

## GN Package 16-Lead Plastic SSOP (Narrow 0.150) (LTC DWG # 05-08-1641)



\* DIMENSION DOES NOT INCLUDE MOLD FLASH. MOLD FLASH SHALL NOT EXCEED 0.006" (0.152mm) PER SIDE  
 \*\* DIMENSION DOES NOT INCLUDE INTERLEAD FLASH. INTERLEAD FLASH SHALL NOT EXCEED 0.010" (0.254mm) PER SIDE

GN16 (SSOP) 0695

## N Package 16-Lead PDIP (Narrow 0.300) (LTC DWG # 05-08-1510)

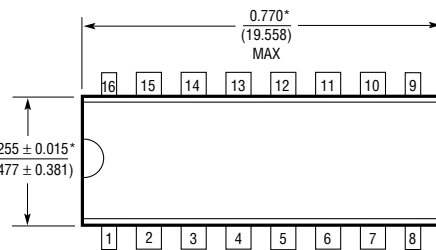
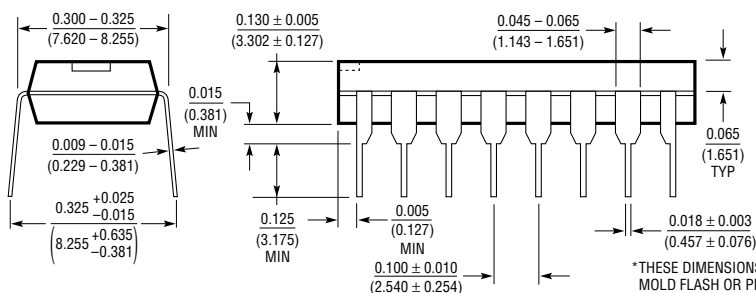

\* THESE DIMENSIONS DO NOT INCLUDE MOLD FLASH OR PROTRUSIONS. MOLD FLASH OR PROTRUSIONS SHALL NOT EXCEED 0.010 INCH (0.254mm)

N16 0695

## S8 Package 8-Lead Plastic Small Outline (Narrow 0.150) (LTC DWG # 05-08-1610)

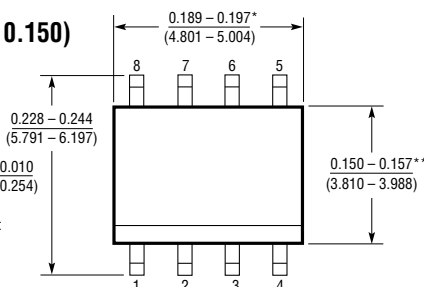
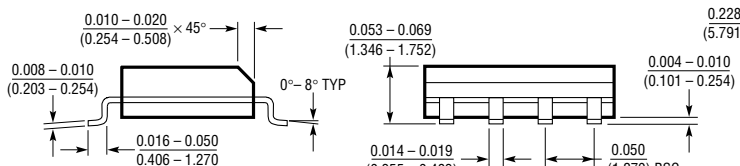

\* DIMENSION DOES NOT INCLUDE MOLD FLASH. MOLD FLASH SHALL NOT EXCEED 0.006" (0.152mm) PER SIDE  
 \*\* DIMENSION DOES NOT INCLUDE INTERLEAD FLASH. INTERLEAD FLASH SHALL NOT EXCEED 0.010" (0.254mm) PER SIDE

S08 0695

## TYPICAL APPLICATION

### Adjustable Voltage Regulator with Precision Adjustable Current Limit

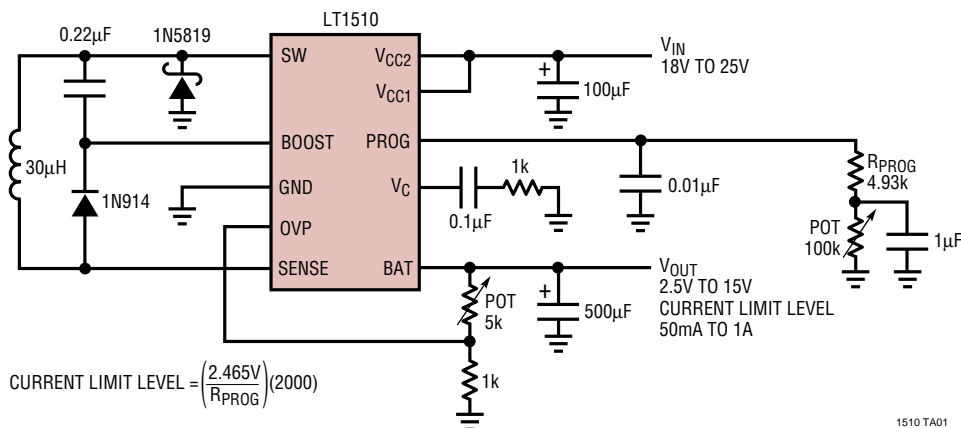

## PACKAGE DESCRIPTION Dimensions in inches (millimeters) unless otherwise noted.

### S Package 16-Lead Plastic Small Outline (Narrow 0.150) (LTC DWG # 05-08-1610)

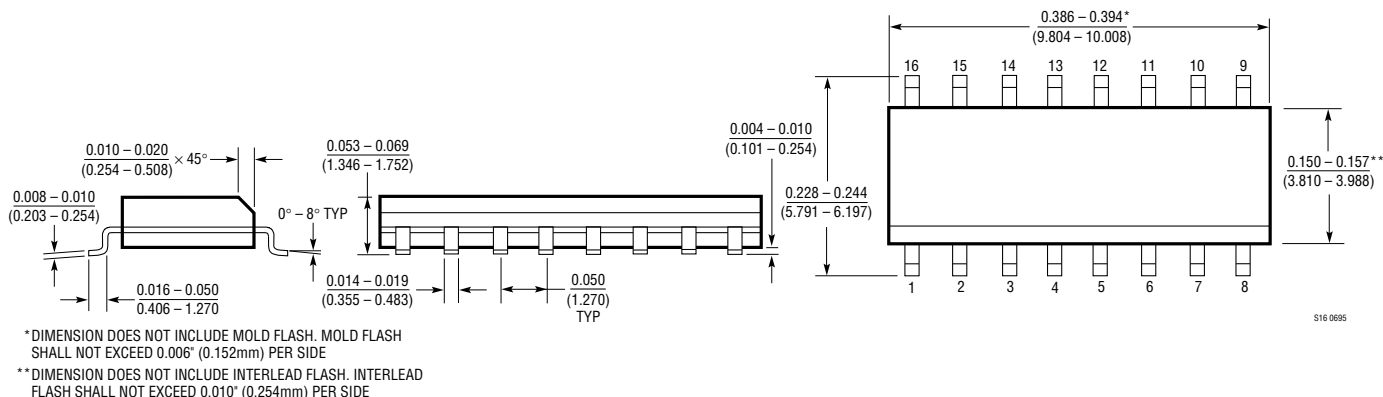

## RELATED PARTS

PART NUMBER	DESCRIPTION	COMMENTS
LTC®1325	Microprocessor-Controlled Battery Management System	Can Charge, Discharge and Gas Gauge NiCd, NiMH and Pb-Acid Batteries with Software Charging Profiles
LT1372/LT1377	500kHz/1MHz Step-Up Switching Regulators	High Frequency, Small Inductor, High Efficiency Switchers, 1.5A Switch
LT1373	250kHz Step-Up Switching Regulator	High Efficiency, Low Quiescent Current, 1.5A Switch
LT1376	500kHz Step-Down Switching Regulator	High Frequency, Small Inductor, High Efficiency Switcher, 1.5A Switch
LT1511	3A Constant-Voltage/Constant-Current Battery Charger	High Efficiency, Minimal External Components to Fast Charge Lithium, NiMH and NiCd Batteries
LT1512	SEPIC Battery Charger	V <sub>IN</sub> Can Be Higher or Lower Than Battery Voltage

## Looking for pricing, stock, or lifecycle information?

Click below to explore more details on WIN SOURCE:

 [View LT1510CS#PBF on WIN SOURCE](#)

 [Linear Technology](#) Information

## Optimize Your Supply Chain with WIN SOURCE Solutions

-  Global Sourcing Solution
-  Obsolete Management
-  Cost Control Management
-  Shortage Management
-  Alternative Solution
-  Excess Inventory Management